



CITY OF DETROIT  
DEPARTMENT OF PUBLIC WORKS  
CITY ENGINEERING DIVISION

COLEMAN A. YOUNG MUNICIPAL CENTER  
2 WOODWARD AVE. SUITE 601  
DETROIT, MICHIGAN 48226  
PHONE: (313) 224-3949 • TTY: 711  
FAX: (313) 224-3471  
WWW.DETROITMI.GOV

June 21, 2024  
Honorable City Council:

**RE: Petition No. x2024-198 – The City of Detroit’s Office of Art, Culture, and Entrepreneurship, request for encroachment within the east-west alley bounded by Grand River Ave., Lahser Ave., Orchard Ave., and Greystone Ave. for the installation of various encroachments.**

Petition No. x2024-198 The City of Detroit’s Office of Art, Culture, and Entrepreneurship, request for encroachment within the east-west alley bounded by Grand River Ave. 120 ft. wide, Lahser Ave., 66 ft wide, Orchard Ave., 50 ft wide, and Greystone Ave., 50 ft. wide for the installation of various encroachments.

This request comes as part of a project to activate the east-west vacated alley with a reservation of a utility easement for the creation of shared public spaces to celebrate neighborhoods and promote the installation of art.

The petition was referred to the City Engineering Division – DPW for investigation and report. This is our report.

The request was approved by the Solid Waste Division – DPW, and City Engineering Division – DPW. Traffic Engineering Division

The request was approved by the Detroit Water and Sewerage Department. The DWSD provisions have been made a part of the resolution.

All other involved City Departments, including the Public Lighting Authority and Public Lighting Department; also privately owned utility companies have reported no objections to the encroachment. Provisions protecting all utility installations are part of the attached resolution.

I am recommending adoption of the attached resolution.

Respectfully submitted,

Richard Doherty, P.E., City Engineer  
City Engineering Division – DPW

Cc: Ron Brundidge, Director, DPW  
Mayor’s Office – City Council Liaison

COUNCIL MEMBER \_\_\_\_\_

**RESOLVED**, that the Department of Public Works, City Engineering Division is hereby authorized and directed to issue permits to The City of Detroit's Office of Art, Culture, and Entrepreneurship or their assigns to install and maintain various encroachments within the east-west alley, 16 ft. wide bounded by Grand River Ave., Lahser Ave., Orchard Ave., and Greystone Ave. for the installation of various encroachments;

- 1) One (1) new decorative steel gate posts and paired steel gate door structure within the east-west alley, 16 ft. wide bounded by Grand River Ave., Lahser Ave., Orchard Ave., and Greystone Ave. Said new decorative steel gate posts and paired steel gate doors shall be 72" above grade, and 24" below grade (minimum).
  - One (1) new decorative steel gate posts and paired steel gate door structure bounded by lots 7 and 54, lying 1' northerly of lot 7, and stretching 14' across the alley to 1' southerly of lot 54 of "Willmarth Place Subdivision" Liber 21 Page 41 of Plats, Wayne County Records.
  
- 2) Two (2) new arts alley standard steel post signs within the east-west alley, 16 ft. wide bounded by Grand River Ave., Lahser Ave., Orchard Ave., and Greystone Ave. Said new arts alley standard steel post signs shall be 48" above grade (surface-mounted).
  - One (1) new arts alley standard steel post sign bounded by lots 7 and 54, lying 3' northerly of lot 7 of "Willmarth Place Subdivision" Liber 21 Page 41 of Plats, Wayne County Records.
  - One (1) new arts alley standard steel post sign bounded by lots 55 and 56, lying 1' northerly of lot 55 of "Willmarth Place Subdivision" Liber 21 Page 41 of Plats, Wayne County Records.

PROVIDED, that if there is any cost for the removing and/or rerouting of any utility facilities, it shall be done at the expense of the petitioner and/or property owner; and be it further

PROVIDED, that access is maintained to all fire department connections, and be it further

PROVIDED, that by approval of this petition the Detroit Water and Sewerage Department (DWSD) does not waive any of its rights to its facilities located in the right-of-way, and at all times, DWSD, its agents or employees, shall have the right to enter upon the right-of-way to maintain, repair, alter, service, inspect, or install its facilities. All costs incident to the damaging, dismantling, demolishing, removal and replacement of structures or other improvements herein permitted and incurred in gaining access to DWSD's facilities for maintenance, repairing, alteration, servicing or inspection caused by the encroachment shall be borne by the petitioner. All

costs associated with gaining access to DWSD's facilities, which could normally be expected had the petitioner not encroached into the right-of-way, shall be borne by DWSD; and be it further

PROVIDED, that all construction performed under this petition shall not be commenced until after (5) days written notice to DWSD. Seventy-two (72) hours' notice shall also be provided in accordance with P.A. 53 1974, as amended, utilizing the MISS DIG one call system; and be it further

PROVIDED, that construction under this petition is subject to inspection and approval by DWSD forces. The cost of such inspection shall, at the discretion of DWSD, be borne by the petitioner; and be it further

PROVIDED, that if DWSD facilities located within the right-of-way shall break or be damaged as the result of any action on the part of the petitioner, then in such event the petitioner agrees to be liable for all costs incident to the repair, replacement or relocation of such broken or damaged DWSD facilities; and be it further

PROVIDED, that the petitioner shall hold DWSD harmless for any damages to the encroaching device constructed or installed under this petition which may be caused by the failure of DWSD's facilities; and be it further

PROVIDED, The City of Detroit's Office of Art, Culture, and Entrepreneurship or their assigns shall apply to the Buildings and Safety Engineering Department for a building permit prior to any construction. Also, if it becomes necessary to open cut public streets, bore, jack, occupy or barricade city rights-of-way for maintenance of encroachments such work shall be according to detail permit application drawings submitted to the City Engineering Division – DPW prior to any public right-of-way construction; and further

PROVIDED, that the necessary permits shall be obtained from the City Engineering Division – DPW and the Buildings and Safety Engineering Department. The encroachments shall be constructed and maintained under their rules and regulations; and further

PROVIDED, that all cost for the construction, maintenance, permits and use of the encroachments shall be borne by The City of Detroit's Office of Art, Culture, and Entrepreneurship or their assigns, and further

PROVIDED, that all costs incurred by privately owned utility companies and/or city departments to alter, adjust, and/or relocate their existing utility facilities located in close proximity to the encroachments shall be borne by The City of Detroit's Office of Art, Culture, and Entrepreneurship or their assigns. Should damages to utilities occur The City of Detroit's Office of Art, Culture, and Entrepreneurship or their assigns shall be liable for all incidental repair costs and waives all claims for damages to the encroaching installations; and further

PROVIDED, that no other rights in the public streets, alleys or other public place shall be considered waived by this permission which is granted expressly on the condition that said encroachments shall be removed at any time when so directed by the City Council, and the public

property affected shall be restored to a condition satisfactory to the City Engineering Division – DPW; and further

PROVIDED, that The City of Detroit's Office of Art, Culture, and Entrepreneurship or their assigns shall file with the Department of Public Works – City Engineering Division an indemnity agreement in form approved by the Law Department. The agreement shall save and protect the City of Detroit from any and all claims, damages or expenses that may arise by reason of the issuance of the permits and the faithful or unfaithful performance of The City of Detroit's Office of Art, Culture, and Entrepreneurship or their assigns of the terms thereof. Further, The City of Detroit's Office of Art, Culture, and Entrepreneurship or their assigns shall agree to pay all claims, damages or expenses that may arise out of the use, repair and maintenance of the proposed encroachments; and further

PROVIDED, that construction of the encroachments shall constitute acceptance of the terms and conditions as set forth in this resolution; and be it further

PROVIDED, this resolution is revocable at the will, whim or caprice of the City Council, and The City of Detroit's Office of Art, Culture, and Entrepreneurship acquires no implied or other privileges hereunder not expressly stated herein; and further

PROVIDED, that the encroachment permits shall not be assigned or transferred without the written approval of the City Council; and be it further

PROVIDED, that the City Clerk shall within 30 days record a certified copy of this resolution with the Wayne County Register of Deeds.

MAP-23-43

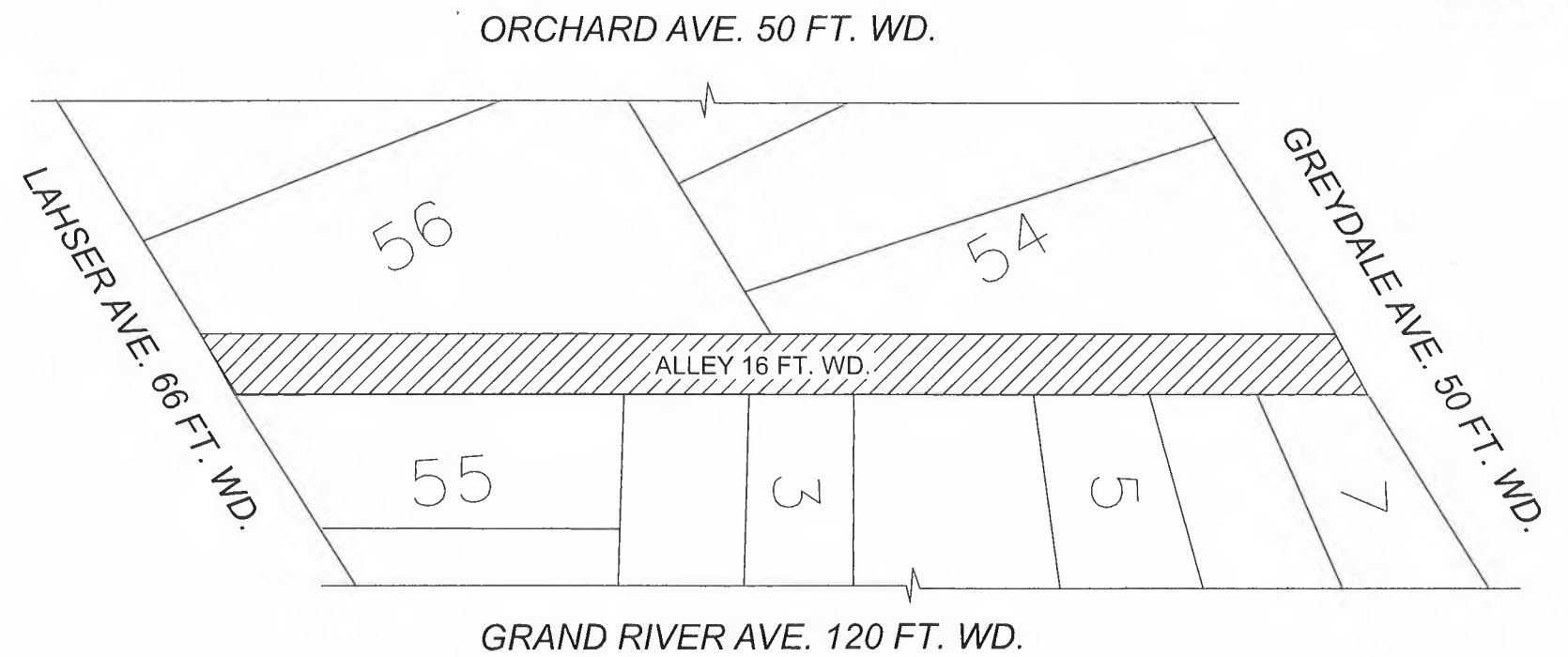

 - REQUEST ALLEY ENCROACHMENT

(FOR OFFICE USE ONLY)

CARTO 114 D

B					
A					
DESCRIPTION	DRWN	CHKD	APPD	DATE	
REVISIONS					
DRAWN BY	LC	CHECKED	AP/TS		
DATE	06-20-2024	APPROVED	RW		

REQUEST ENCROACHMENT INTO THE ALLEY  
BOUNDED BY LAHSER RD., GRAND RIVER AVE.,  
GREYDALE AVE., AND ORCHARD AVE.

CITY OF DETROIT  
CITY ENGINEERING DIVISION  
SURVEY BUREAU

JOB NO. 23-43

DRWG. NO. 01

MAP-23-43

ORCHARD AVE. 50 FT. WD.

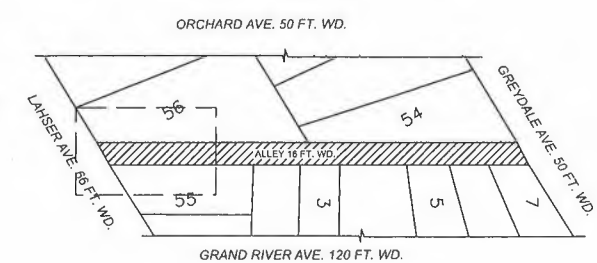
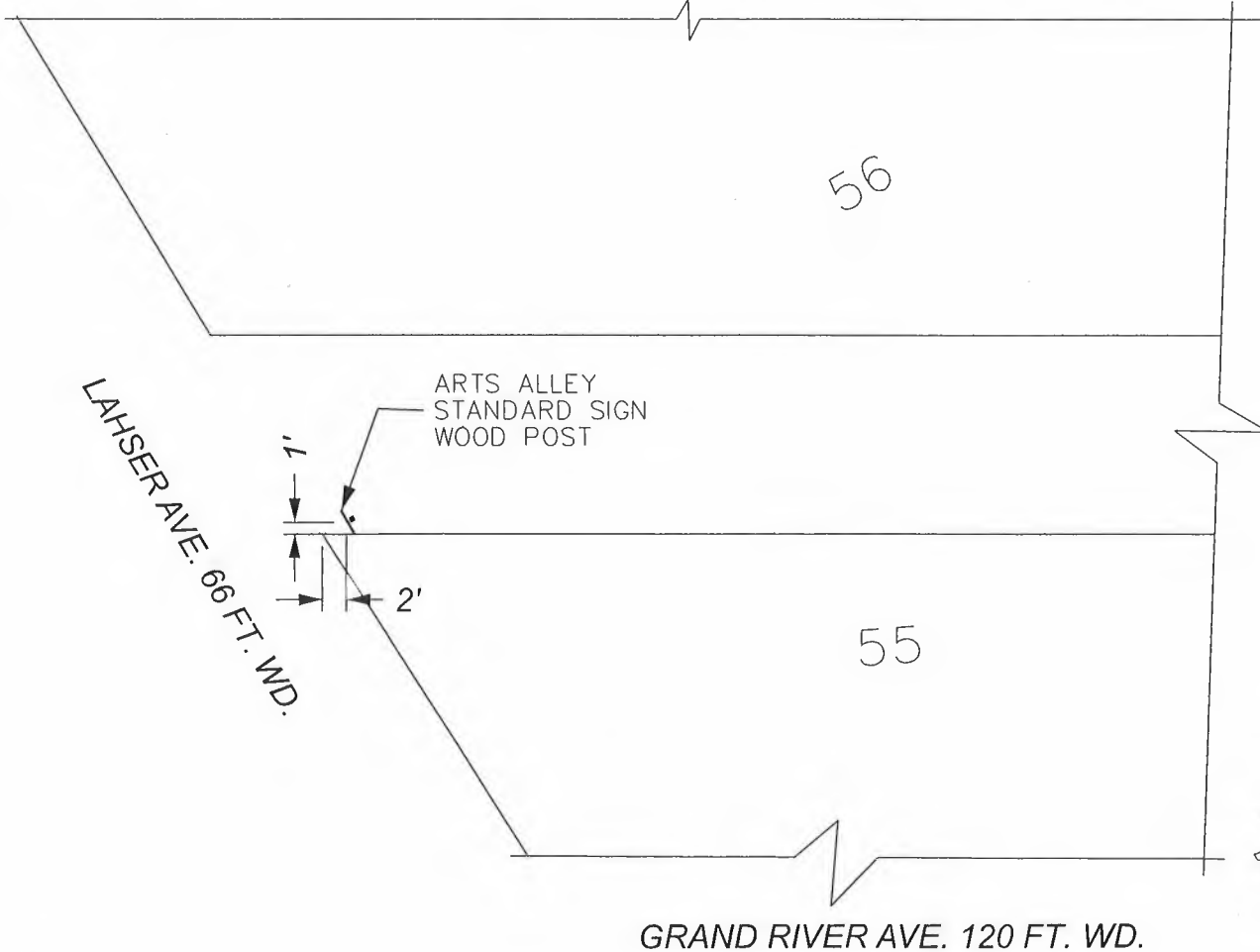

■ - POST + SIGN

▨ - REQUEST ALLEY ENCROACHMENT

CARTO 114 D

B					
A					
DESCRIPTION	DRWN	CHKD	APPD	DATE	
REVISIONS					
DRAWN BY	LC	CHECKED	AP/TS		
DATE	06-20-2024	APPROVED	RW		

REQUEST ENCROACHMENT INTO THE ALLEY BOUNDED BY LAHSER RD., GRAND RIVER AVE., GREYDALE AVE., AND ORCHARD AVE.

CITY OF DETROIT  
CITY ENGINEERING DIVISION  
SURVEY BUREAU

JOB NO. 23-43

DRWG. NO. 02

MAP-23-43

ORCHARD AVE. 50 FT. WD.



LAHSER AVE. 66 FT. WD.

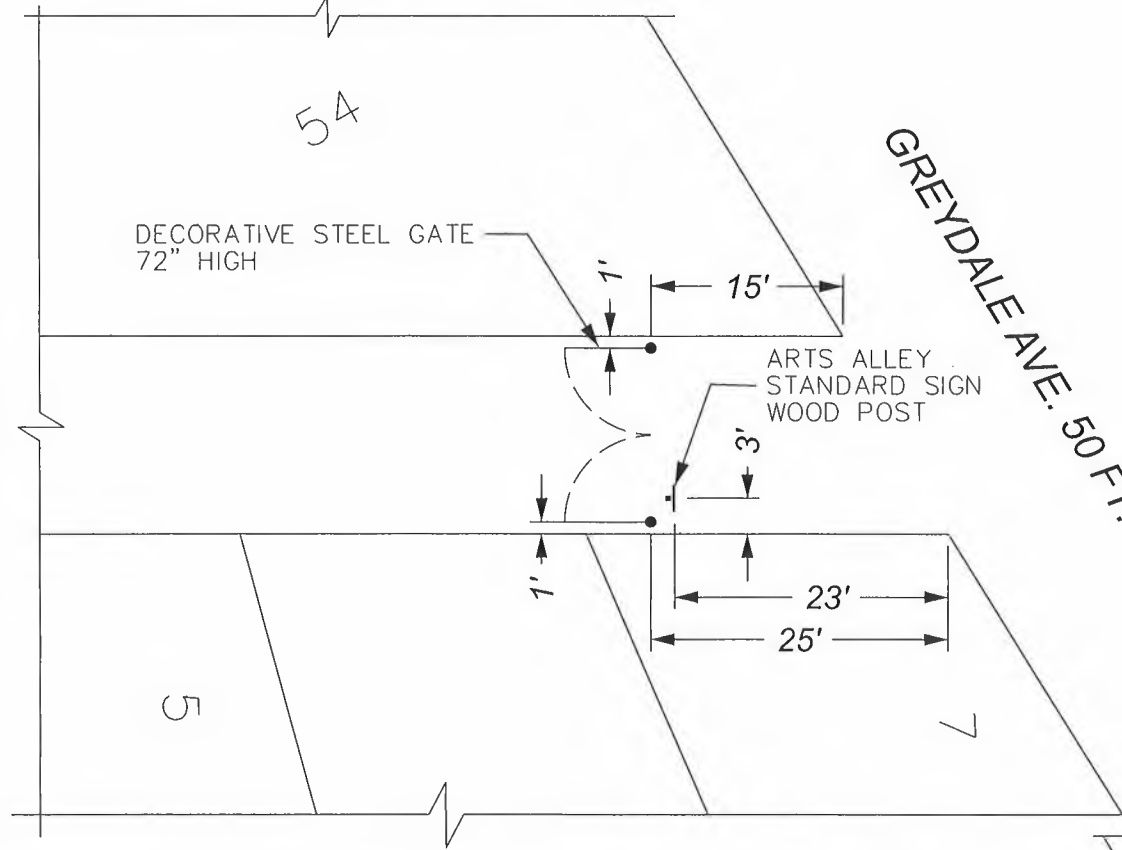

GREYDALE AVE. 50 FT. WD.

GRAND RIVER AVE. 120 FT. WD.

- - POST + SIGN
- - STEEL GATE POST AND FRAMEWORK 72" HIGH
- ▨ - REQUEST ALLEY ENCROACHMENT

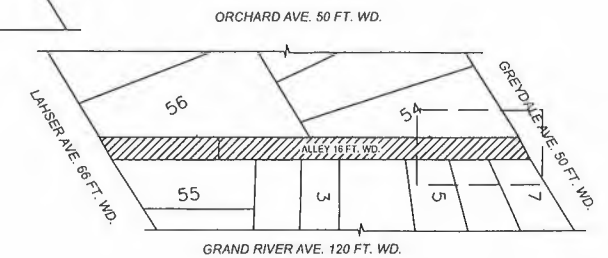

CARTO 114 D

B					
A					
DESCRIPTION	DRWN	CHKD	APPD	DATE	
REVISIONS					
DRAWN BY	LC	CHECKED	AP/TS		
DATE	06-20-2024	APPROVED	RW		

**REQUEST ENCROACHMENT INTO THE ALLEY BOUNDED BY LAHSER RD., GRAND RIVER AVE., GREYDALE AVE., AND ORCHARD AVE.**

CITY OF DETROIT CITY ENGINEERING DIVISION SURVEY BUREAU	
JOB NO.	23-43
DRWG. NO.	03