

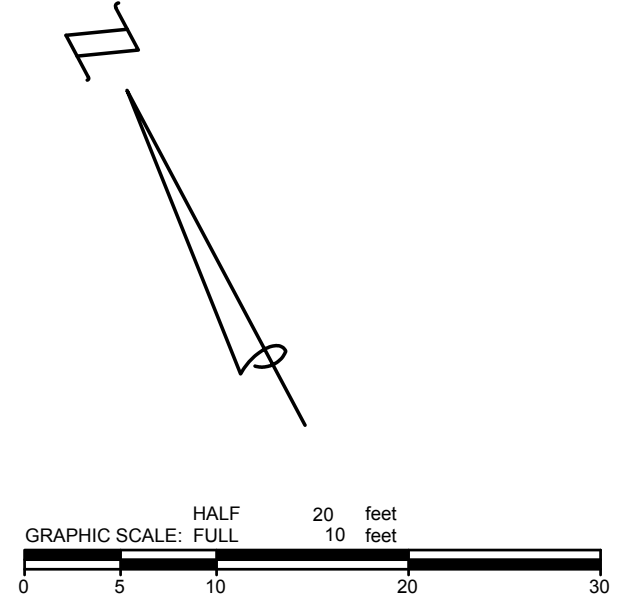

OLD REDFORD ARTS ALLEY

(16' R.O.W.)

JOB BENCHMARK #207 DESCRIPTION: SET COTTON SPINDLE IN S/FACE OF U/POLE ON W/SIDE OF GREYDALE ST AT BEGINNING OF ALLEY ELEV 6.35.05
JOB BENCHMARK #208 DESCRIPTION: SET COTTON SPINDLE IN S/FACE OF U/POLE NEAR MID POINT OF ALLEY, +/-15FT NE OF CB#1529 ELEV 6.36.39
JOB BENCHMARK #209 DESCRIPTION: SET COTTON SPINDLE ON E/FACE OF U/POLE ON W SIDE OF LAHSER RD AT ALLEY INTERSECTION ELEV 6.36.05
TRAVERSE POINT #107 N 335980.45 E 13423160.35 ELEV 633.88
TRAVERSE POINT #108 N 336070.76 E 13422989.20 ELEV 635.32
TRAVERSE POINT #109 N 336158.16 E 13422830.89 ELEV 635.89

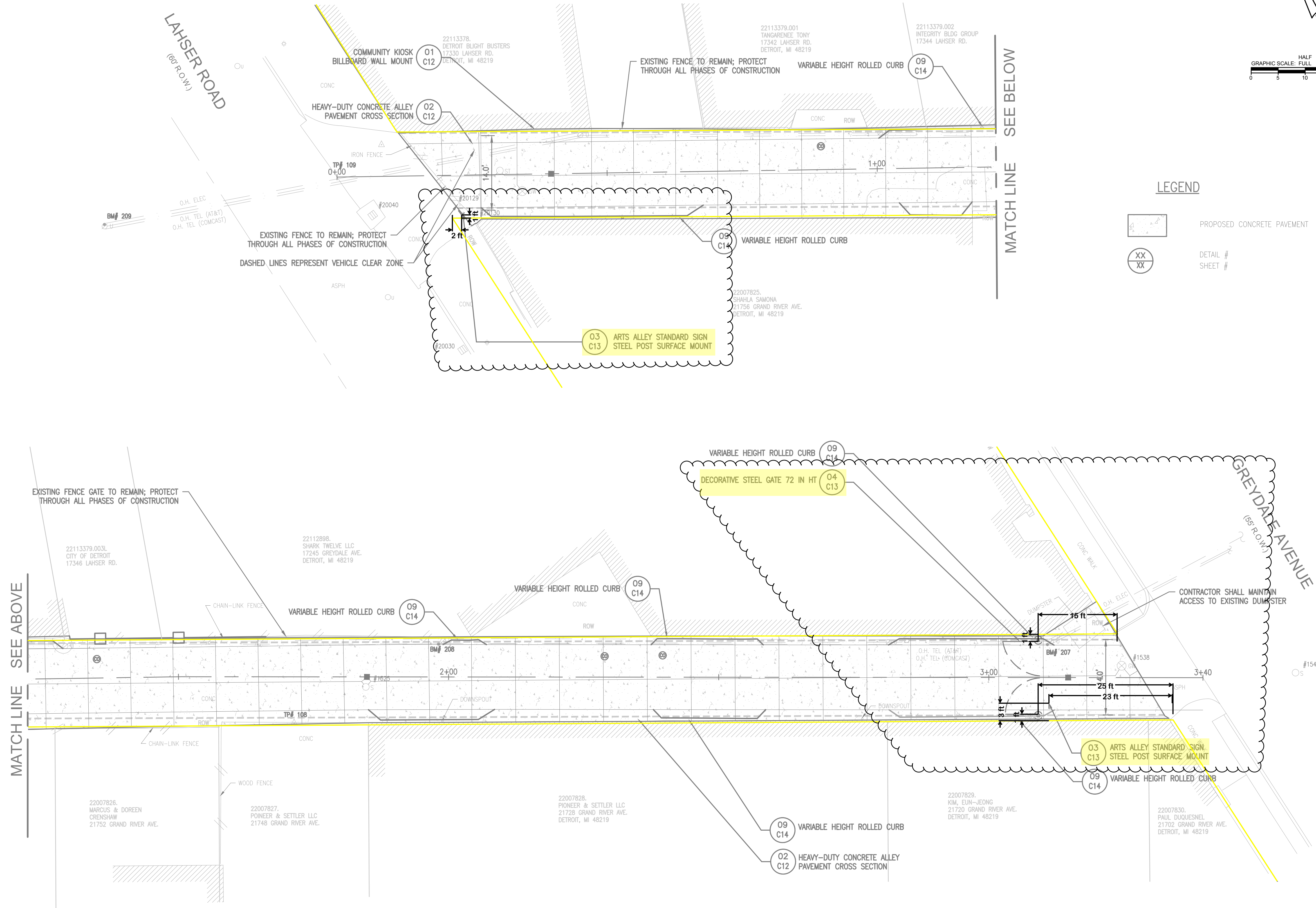

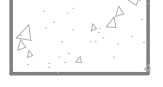
LEGEND

-  PROPOSED CONCRETE PAVEMENT
-  DETAIL #
-  SHEET #

MATCH LINE SEE ABOVE

MATCH LINE SEE BELOW

DRAWING PATH: P:\3501_7600782222010_Arts Alleys\Drawings\Civil\Plans_Const\220101STE_REDE.dwg Nov 21, 2023 - 1:42pm

NOTE:
CONTRACTOR TO REVIEW LOCATIONS FOR SITE FURNISHINGS WITH OWNER AND ENGINEER PRIOR TO FINAL INSTALLATION.
MODIFICATIONS TO LOCATIONS MAY BE MADE AT THE DISCRETION OF THE OWNER AT NO ADDITIONAL COST



OHM
ARCHITECTS ENGINEERS PLANNERS
1145 Griswold, Suite 200
Detroit, MI 48226
P (313) 481-1250
OHM-ADVISORS.COM



livingLAB

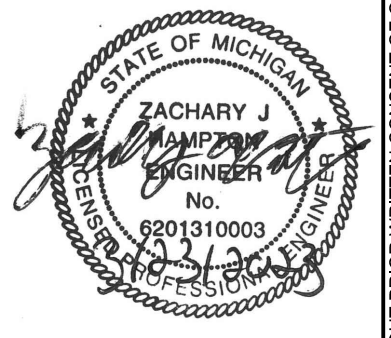

REVISIONS	DATE	PROJ NUMBER	ENG	PROJ INGR	CADD	COUNTY	MUNICIPALITY
		7522-00-010	ZJH	GCR	MI	WAYNE	DETROIT

CITY OF DETROIT
ART ALLEYS - PHASE 1
SITE LAYOUT PLAN

SHEET
C7

COPYRIGHT 2016 OHM ALL DRAWINGS AND WRITTEN MATERIALS APPEARING HEREIN CONSTITUTE THE ORIGINAL AND UNPUBLISHED WORK OF OHM AND THE SAME MAY NOT BE DUPLICATED, DISTRIBUTED, OR DISCLOSED WITHOUT PRIOR WRITTEN CONSENT OF OHM

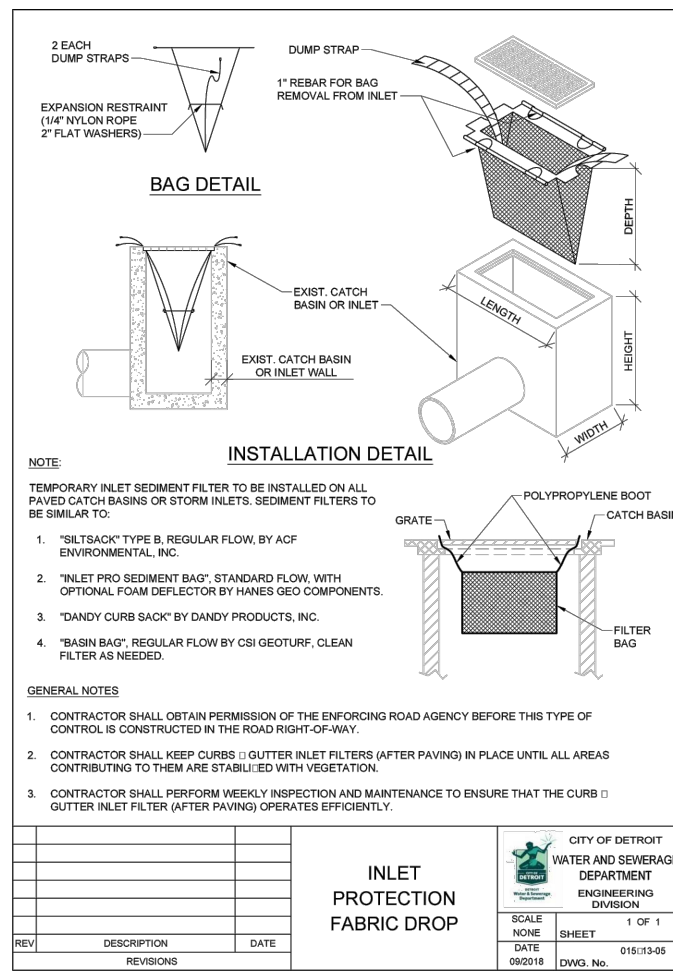

05 INLET FILTER NOT TO SCALE

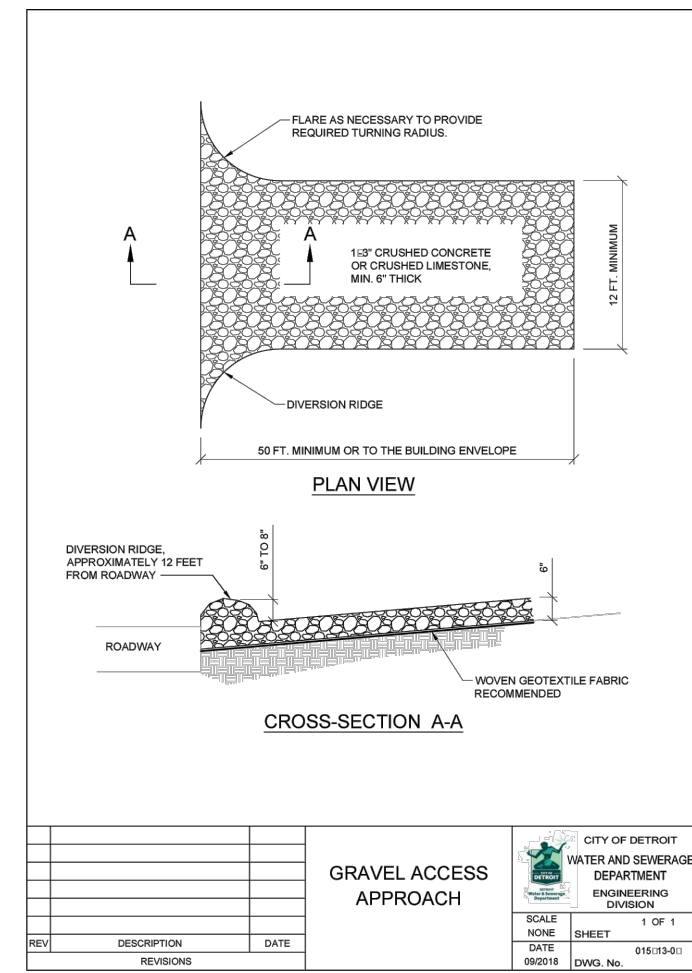

06 AGGREGATE TRACKING MAT NOT TO SCALE

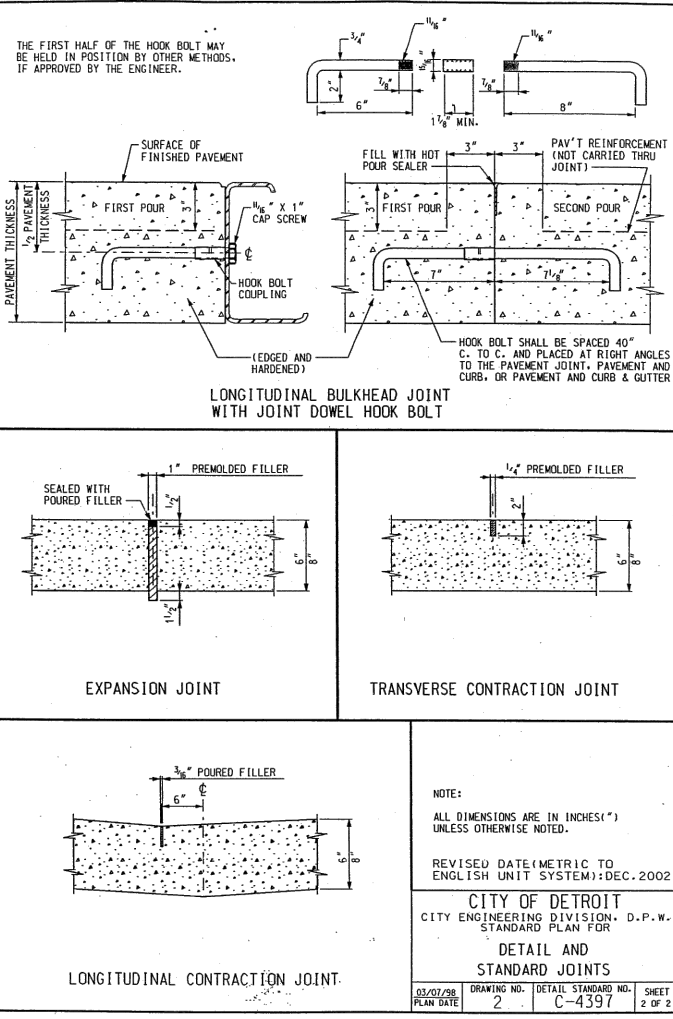
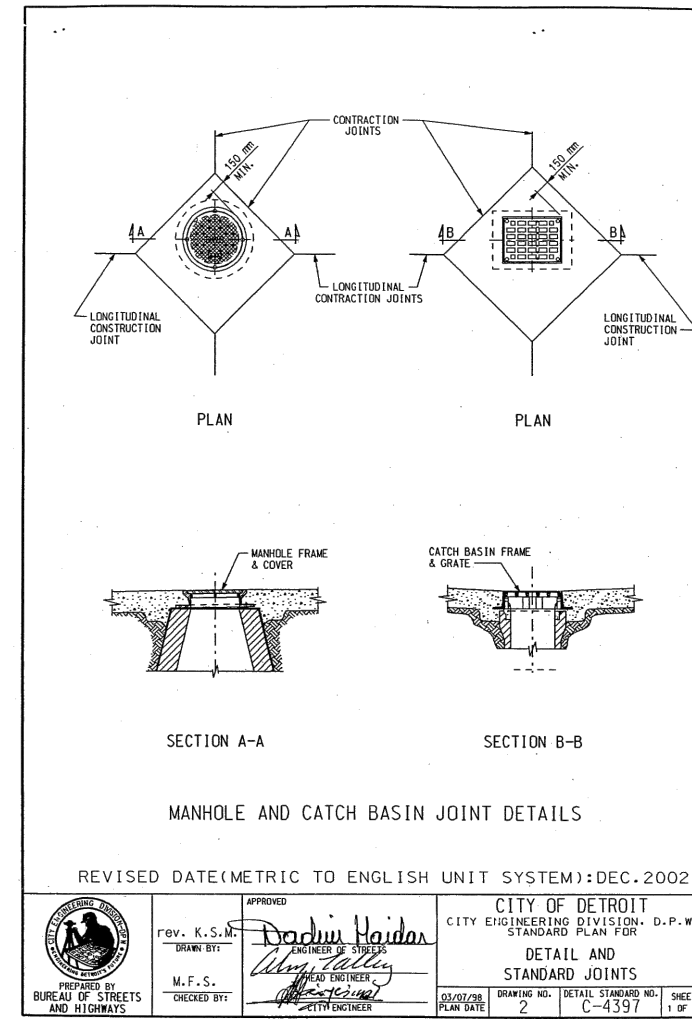

07 DETAIL AND STANDARD JOINTS - CITY OF DETROIT NOT TO SCALE

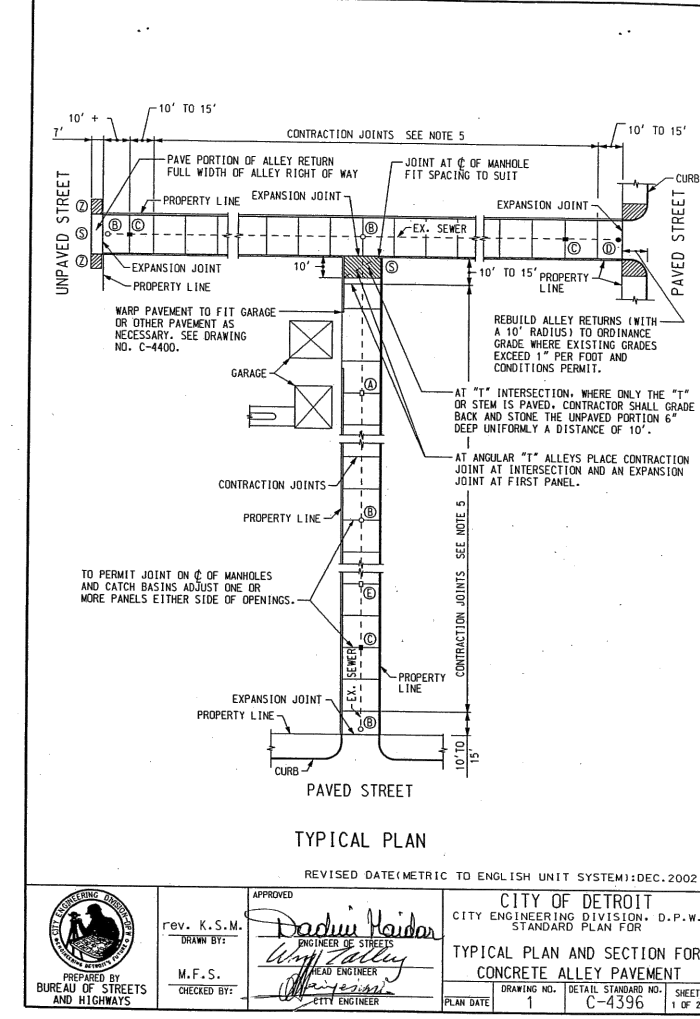

08 ALLEY PLAN AND SECTION - CITY OF DETROIT NOT TO SCALE

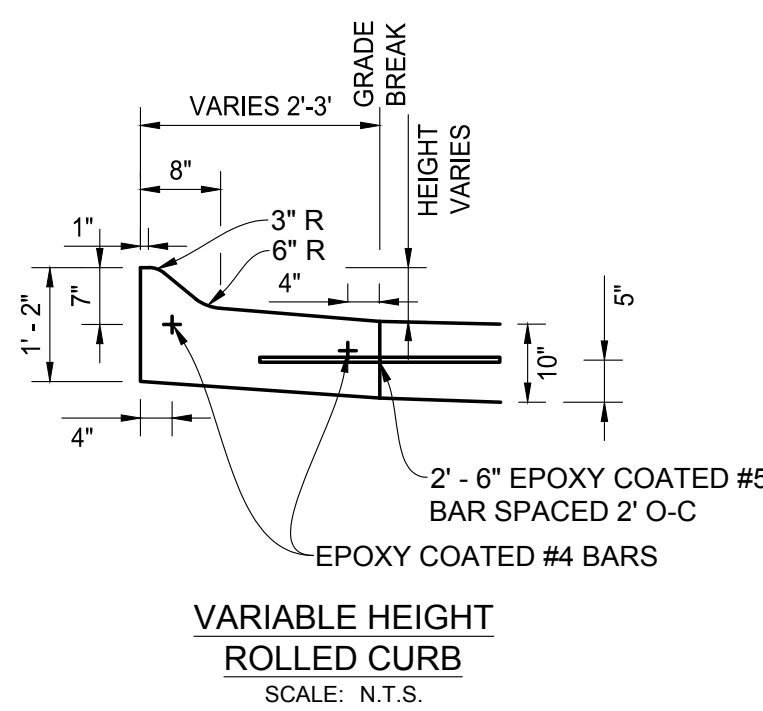

09 VARIABLE HEIGHT ROLLED CURB NOT TO SCALE



ARCHITECTS ENGINEERS PLANNERS

1145 Griswold, Suite 200
Detroit, MI 48226
P (313) 481-1250

OHM-ADVISORS.COM



livingLAB



REVISIONS

MUNICIPALITY

COUNTY

CARD

PROLUMER

ENG

DATE

SHEET

CITY OF DETROIT
ART ALLEYS - PHASE 1
SITE/CIVIL DETAILS

C14

COPYRIGHT 2016 OHM ARCHITECTS ENGINEERS PLANNERS AND WRITTEN MATERIALS APPEARING HEREIN CONSTITUTE THE ORIGINAL AND UNPUBLISHED WORK OF OHM AND THE SAME MAY NOT BE REPRODUCED, DISTRIBUTED, OR DISCLOSED WITHOUT PRIOR WRITTEN CONSENT OF OHM.