



May 28, 2024

Honorable City Council:

RE: Petition No. x2024-136 – The City of Detroit’s Office of Art, Culture, and Entrepreneurship, request for encroachment within the north-south public alley bounded by Oakland Ave., Westminster Ave., Goodwin Ave., and Owen Ave. for the installation of various encroachments.

Petition No. x2024-136 The City of Detroit’s Office of Art, Culture, and Entrepreneurship, request for encroachment within the north-south public alley 15 ft. wide, bounded by Oakland Ave. 66 ft. wide, Westminster Ave. 50 ft wide, Goodwin Ave. 50 ft. wide, and Owen Ave. 60 ft. wide, for the installation of various encroachments.

This request comes as part of a project to activate the north-south alley for the creation of shared public spaces to celebrate neighborhoods and promote the installation of art.

The petition was referred to the City Engineering Division – DPW for investigation and report. This is our report.

The request was approved by the Solid Waste Division – DPW, and City Engineering Division – DPW. Traffic Engineering Division

The request was approved by the Detroit Water and Sewerage Department. The DWSD provisions have been made a part of the resolution.

All other involved City Departments, including the Public Lighting Authority and Public Lighting Department; also privately owned utility companies have reported no objections to the encroachment. Provisions protecting all utility installations are part of the attached resolution.

I am recommending adoption of the attached resolution.

Respectfully submitted,

Richard Doherty, P.E., City Engineer
City Engineering Division – DPW

Cc: Ron Brundidge, Director, DPW
Mayor's Office – City Council Liaison

RESOLVED, that the Department of Public Works, City Engineering Division is hereby authorized and directed to issue permits to The City of Detroit's Office of Art, Culture, and Entrepreneurship or their assigns to install and maintain various encroachments within the north-south public alley bounded by Oakland Ave., Westminster Ave., Goodwin Ave., and Owen Ave, further described as: Land in the City of Detroit, Wayne County, Michigan;

- 1) New standard-duty concrete paving, exposed-aggregate concrete paving, and variable-height rolled curbs throughout the north-south alley 15 ft. wide, bounded by Oakland Ave. 66 ft. wide, Westminster Ave. 50 ft wide, Goodwin Ave. 50 ft. wide, and Owen Ave. 60 ft. wide, lying easterly of lots 24-44 and westerly of lots 45-65 of "Mott & Morse's Subdivision" Liber 15 Page 81 of Plats, Wayne County Records, lying easterly of lots 1-6 and westerly of lots 46-51 of "Galloway and Butterfield's Subdivision" Liber 13 Page 59 of Plats, Wayne County Records.
- 2) Nine (9) new cast iron decorative surface mounted removable bollards within the north-south alley 15 ft. wide, bounded by Oakland Ave. 66 ft. wide, Westminster Ave. 50 ft wide, Goodwin Ave. 50 ft. wide, and Owen Ave. 60 ft. wide. Said new surface-mounted removable metal bollards shall be 35" in length and 12" in depth.
 - Three (3) new cast iron decorative bollards bounded by lots 6 and 46. Lying 1' easterly of lot 6, lying 7.5' easterly of lot 6, and lying 3.5' westerly of lot 46 of "Galloway and Butterfield's Subdivision" Liber 13 Page 59 of Plats, Wayne County Records.
 - Three (3) new cast iron decorative bollards bounded by lots 30 and 59. Lying 3.5' easterly of lot 30, lying 7.5' easterly of lot 30, and lying 3.5' westerly of lot 59 of "Mott & Morse's Subdivision" Liber 15 Page 81 of Plats Wayne County Records.
 - Three (3) new cast iron decorative bollards bounded by lots 24 and 65. Lying 3.5' easterly of lot 24, lying 7.5' easterly of lot 24, and lying 11.5' easterly of lot 24 of "Mott & Morse's Subdivision" Liber 15 Page 81 of Plats, Wayne County Records.
- 3) Three (3) new arts alley standard signs within the north-south alley 15 ft. wide, bounded by Oakland Ave. 66 ft. wide, Westminster Ave. 50 ft wide, Goodwin Ave. 50 ft. wide, and Owen Ave. 60 ft. wide. Said new arts alley standard signs shall be 48" above grade and 3' in depth.
 - One (1) new arts alley standard sign bounded by lots 6 and 46 shall be 1' lying westerly from and adjacent to lot 46 of the Mott & Morse's Subdivision" Liber 15 Page 81 and the "Galloway and Butterfield's Subdivision" Liber 13 Page 59 of Plats, Wayne County Records.

- One (1) new arts alley standard sign bounded by lots 30 and 59 shall be 1' lying easterly from and adjacent to lot 30 of the "Mott & Morse's Subdivision" Liber 15 Page 81 and the "Galloway and Butterfield's Subdivision" Liber 13 Page 59 of Plats, Wayne County Records.
 - One (1) new arts alley standard sign bounded by lots 24 and 65 shall be 1' lying easterly from and adjacent to lot 24 of the "Mott & Morse's Subdivision" Liber 15 Page 81 and the "Galloway and Butterfield's Subdivision" Liber 13 Page 59 of Plats, Wayne County Records.
- 4) Two (2) new in-ground metal post pet waste stations within the north-south alley 15 ft. wide, bounded by Oakland Ave. 66 ft. wide, Westminster Ave. 50 ft wide, Goodwin Ave. 50 ft. wide, and Owen Ave. 60 ft. wide. Said new in-ground post pet waste stations shall be 72" above grade, and 24" below grade (minimum).
- One (1) new in-ground post pet waste stations bounded by lots 6 and 46 shall be 1' lying westerly from and adjacent to lot 46 of the "Mott & Morse's Subdivision" Liber 15 Page 81 and the "Galloway and Butterfield's Subdivision" Liber 13 Page 59 of Plats, Wayne County Records.
 - One (1) new in-ground post pet waste station bounded by lots 24 and 65 shall be 13' lying easterly from lot 24 of the "Mott & Morse's Subdivision" Liber 15 Page 81 and the "Galloway and Butterfield's Subdivision" Liber 13 Page 59 of Plats, Wayne County Records.

PROVIDED, that if there is any cost for the removing and/or rerouting of any utility facilities, it shall be done at the expense of the petitioner and/or property owner; and be it further

PROVIDED, that access is maintained to all fire department connections, and be it further

PROVIDED, that by approval of this petition the Detroit Water and Sewerage Department (DWSD) does not waive any of its rights to its facilities located in the right-of-way, and at all times, DWSD, its agents or employees, shall have the right to enter upon the right-of-way to maintain, repair, alter, service, inspect, or install its facilities. All costs incident to the damaging, dismantling, demolishing, removal and replacement of structures or other improvements herein permitted and incurred in gaining access to DWSD's facilities for maintenance, repairing, alteration, servicing or inspection caused by the encroachment shall be borne by the petitioner. All

costs associated with gaining access to DWSD's facilities, which could normally be expected had the petitioner not encroached into the right-of-way, shall be borne by DWSD; and be it further

PROVIDED, that all construction performed under this petition shall not be commenced until after (5) days written notice to DWSD. Seventy-two (72) hours' notice shall also be provided in accordance with P.A. 53 1974, as amended, utilizing the MISS DIG one call system; and be it further

PROVIDED, that construction under this petition is subject to inspection and approval by DWSD forces. The cost of such inspection shall, at the discretion of DWSD, be borne by the petitioner; and be it further

PROVIDED, that if DWSD facilities located within the right-of-way shall break or be damaged as the result of any action on the part of the petitioner, then in such event the petitioner agrees to be liable for all costs incident to the repair, replacement or relocation of such broken or damaged DWSD facilities; and be it further

PROVIDED, that the petitioner shall hold DWSD harmless for any damages to the encroaching device constructed or installed under this petition which may be caused by the failure of DWSD's facilities; and be it further

PROVIDED, The City of Detroit's Office of Art, Culture, and Entrepreneurship or their assigns shall apply to the Buildings and Safety Engineering Department for a building permit prior to any construction. Also, if it becomes necessary to open cut public streets, bore, jack, occupy or barricade city rights-of-way for maintenance of encroachments such work shall be according to detail permit application drawings submitted to the City Engineering Division – DPW prior to any public right-of-way construction; and further

PROVIDED, that the necessary permits shall be obtained from the City Engineering Division – DPW and the Buildings and Safety Engineering Department. The encroachments shall be constructed and maintained under their rules and regulations; and further

PROVIDED, that all cost for the construction, maintenance, permits and use of the encroachments shall be borne by The City of Detroit's Office of Art, Culture, and Entrepreneurship or their assigns, and further

PROVIDED, that all costs incurred by privately owned utility companies and/or city departments to alter, adjust, and/or relocate their existing utility facilities located in close proximity to the encroachments shall be borne by The City of Detroit's Office of Art, Culture, and Entrepreneurship or their assigns. Should damages to utilities occur The City of Detroit's Office of Art, Culture, and Entrepreneurship or their assigns shall be liable for all incidental repair costs and waives all claims for damages to the encroaching installations; and further

PROVIDED, that no other rights in the public streets, alleys or other public place shall be considered waived by this permission which is granted expressly on the condition that said encroachments shall be removed at any time when so directed by the City Council, and the public

property affected shall be restored to a condition satisfactory to the City Engineering Division – DPW; and further

PROVIDED, that The City of Detroit’s Office of Art, Culture, and Entrepreneurship or their assigns shall file with the Department of Public Works – City Engineering Division an indemnity agreement in form approved by the Law Department. The agreement shall save and protect the City of Detroit from any and all claims, damages or expenses that may arise by reason of the issuance of the permits and the faithful or unfaithful performance of The City of Detroit’s Office of Art, Culture, and Entrepreneurship or their assigns of the terms thereof. Further, The City of Detroit’s Office of Art, Culture, and Entrepreneurship or their assigns shall agree to pay all claims, damages or expenses that may arise out of the use, repair and maintenance of the proposed encroachments; and further

PROVIDED, that construction of the encroachments shall constitute acceptance of the terms and conditions as set forth in this resolution; and be it further

PROVIDED, this resolution is revocable at the will, whim or caprice of the City Council, and The City of Detroit’s Office of Art, Culture, and Entrepreneurship acquires no implied or other privileges hereunder not expressly stated herein; and further

PROVIDED, that the encroachment permits shall not be assigned or transferred without the written approval of the City Council; and be it further

PROVIDED, that the City Clerk shall within 30 days record a certified copy of this resolution with the Wayne County Register of Deeds.

WESTMINSTER AVE. 50 FT. WD.



→ ← 15'

OAKLAND AVE. 66 FT. WD.

GOODWIN AVE. 50 FT. WD.

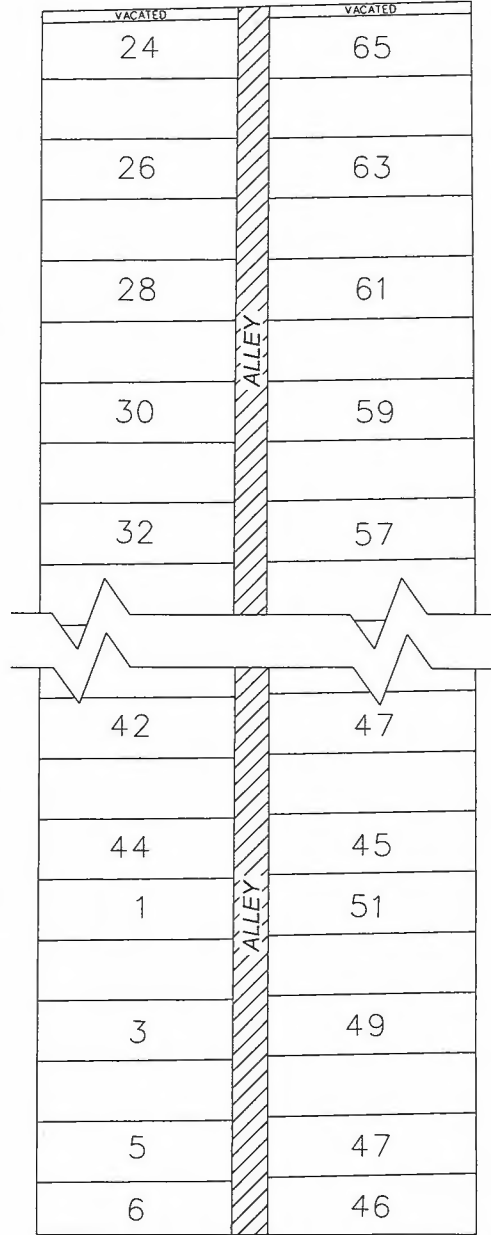

OWEN AVE. 60 FT. WD.

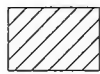

- REQUEST ENCROACHMENT
(NEW CONCRETE PAVEMENT, BOLLARDS, SIGNS, PET STATIONS,
AND ASSOCIATED WATER/POWER INFRASTRUCTURE IMPROVEMENTS)

(FOR OFFICE USE ONLY)

CARTO 42 C / 42 D

| B | | | | | |
|-------------|------------|----------|-------|------|--|
| A | | | | | |
| DESCRIPTION | DRWN | CHKD | APPD | DATE | |
| REVISIONS | | | | | |
| DRAWN BY | TS | CHECKED | AP/LC | | |
| DATE | 05-30-2024 | APPROVED | RW | | |

REQUEST ENCROACHMENT INTO
THE NORTH/SOUTH ALLEY, 15 FT. WD.
IN THE BLOCK BOUNDED BY
GOODWIN AVE., OWEN AVE., OAKLAND AVE.,
AND WESTMINSTER AVE.

| | |
|---|-------|
| CITY OF DETROIT CITY ENGINEERING DIVISION SURVEY BUREAU | |
| JOB NO. | 24-17 |
| DRWG. NO. | 01 |

MAP-24-17

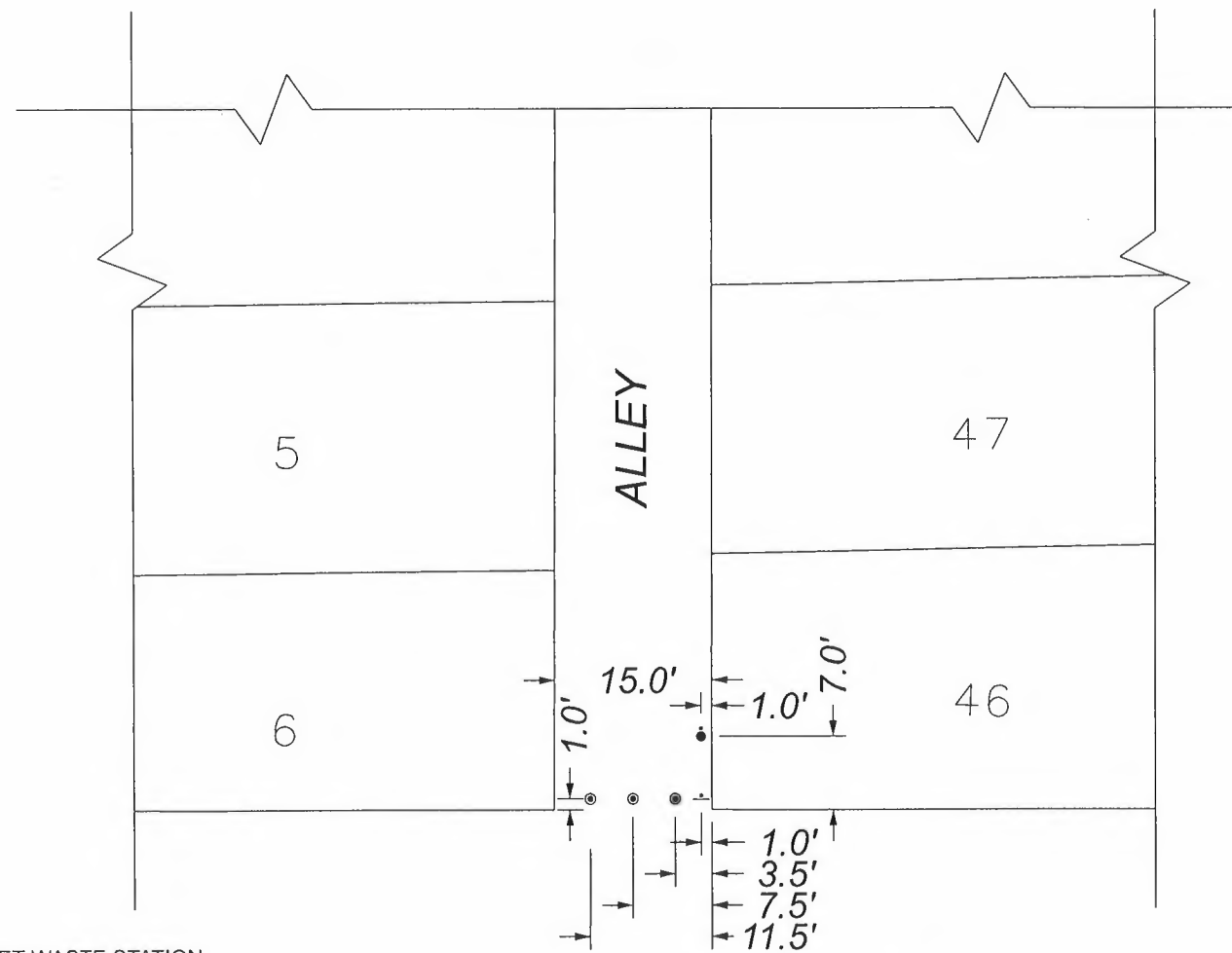

WESTMINSTER AVE.

OAKLAND AVE.

GOODWIN AVE.

| | |
|----|----|
| 24 | 65 |
| 26 | 63 |
| 28 | 61 |
| 30 | 59 |
| 32 | 57 |
| 34 | 55 |
| 36 | 53 |
| 38 | 51 |
| 40 | 49 |
| 42 | 47 |
| 44 | 45 |
| 1 | 51 |
| 3 | 49 |
| 5 | 47 |
| 6 | 46 |

OWEN AVE.

- - PET WASTE STATION (IN-GROUND)
- - ARTS ALLEY STANDARD SIGN (SURFACE MOUNT)
- - CAST IRON DECORATIVE BOLLARD (SURFACE MOUNT - REMOVABLE)

OWEN AVE. 60 FT. WD.

(FOR OFFICE USE ONLY)

CARTO 42 C / 42 D

| B | | | | | |
|-------------|------------|----------|-------|------|--|
| A | | | | | |
| DESCRIPTION | DRWN | CHKD | APPD | DATE | |
| REVISIONS | | | | | |
| DRAWN BY | TS | CHECKED | AP/LC | | |
| DATE | 05-30-2024 | APPROVED | RW | | |

REQUEST ENCROACHMENT INTO THE NORTH/SOUTH ALLEY, 15 FT. WD. IN THE BLOCK BOUNDED BY GOODWIN AVE., OWEN AVE., OAKLAND AVE., AND WESTMINSTER AVE.

CITY OF DETROIT
CITY ENGINEERING DIVISION
SURVEY BUREAU

JOB NO. 24-17

DRWG. NO. 02

MAP-24-17

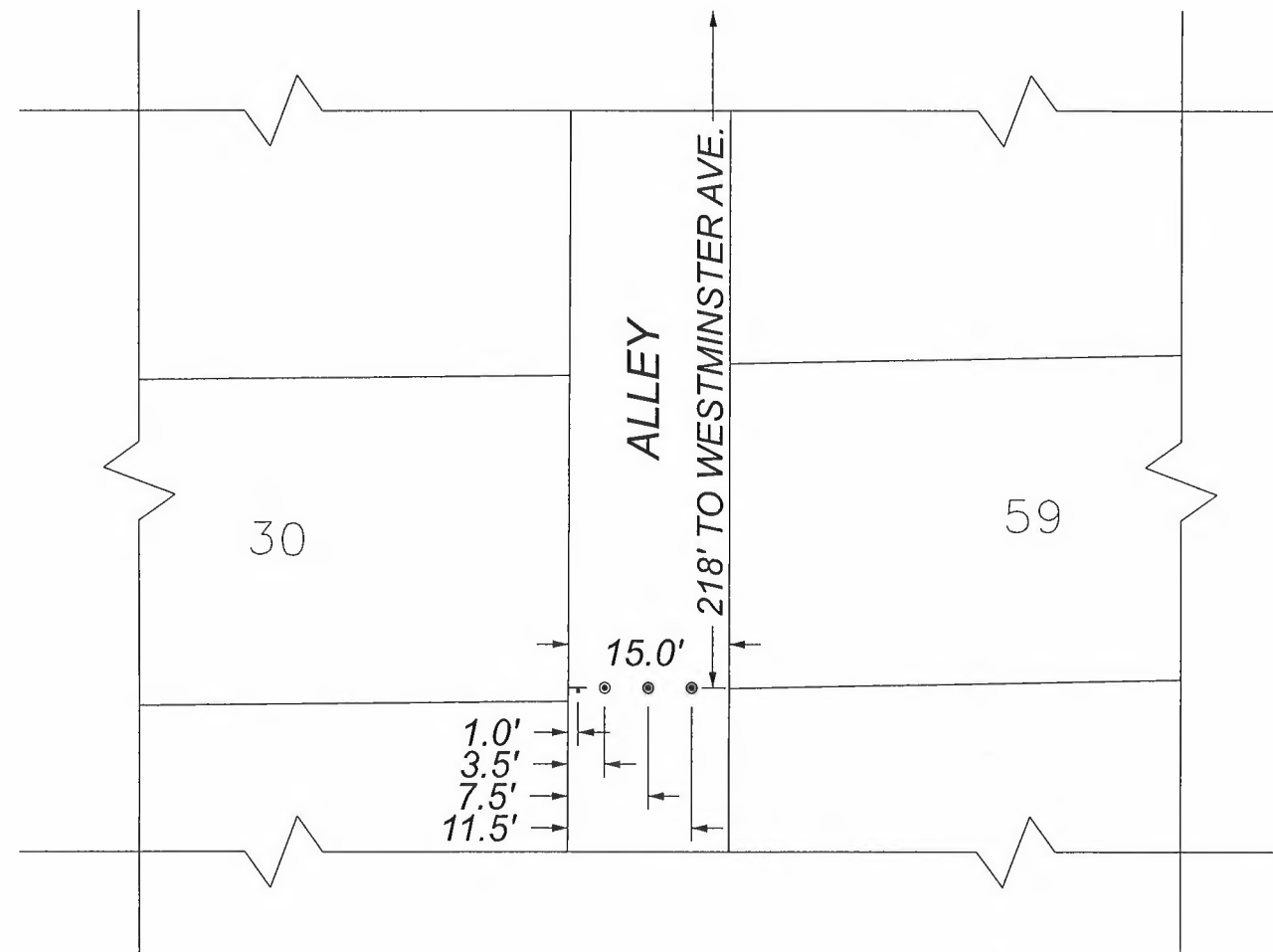

WESTMINSTER AVE.

OAKLAND AVE.

GOODWIN AVE.

| | |
|----|----|
| 24 | 65 |
| 26 | 63 |
| 28 | 61 |
| 30 | 59 |
| 32 | 57 |
| 34 | 55 |
| 36 | 53 |
| 38 | 51 |
| 40 | 49 |
| 42 | 47 |
| 44 | 45 |
| 1 | 51 |
| 3 | 49 |
| 5 | 47 |
| 6 | 46 |

OWEN AVE.

- - ARTS ALLEY STANDARD SIGN (SURFACE MOUNT)
- - CAST IRON DECORATIVE BOLLARD (SURFACE MOUNT - REMOVABLE)

(FOR OFFICE USE ONLY)

CARTO 42 C / 42 D

| B | | | | | |
|-------------|------------|----------|-------|------|--|
| A | | | | | |
| DESCRIPTION | DRWN | CHKD | APPD | DATE | |
| REVISIONS | | | | | |
| DRAWN BY | TS | CHECKED | AP/LC | | |
| DATE | 05-30-2024 | APPROVED | RW | | |

REQUEST ENCROACHMENT INTO THE NORTH/SOUTH ALLEY, 15 FT. WD. IN THE BLOCK BOUNDED BY GOODWIN AVE., OWEN AVE., OAKLAND AVE., AND WESTMINSTER AVE.

CITY OF DETROIT
CITY ENGINEERING DIVISION
SURVEY BUREAU

JOB NO. 24-17

DRWG. NO. 03

WESTMINSTER AVE. 50 FT. WD.

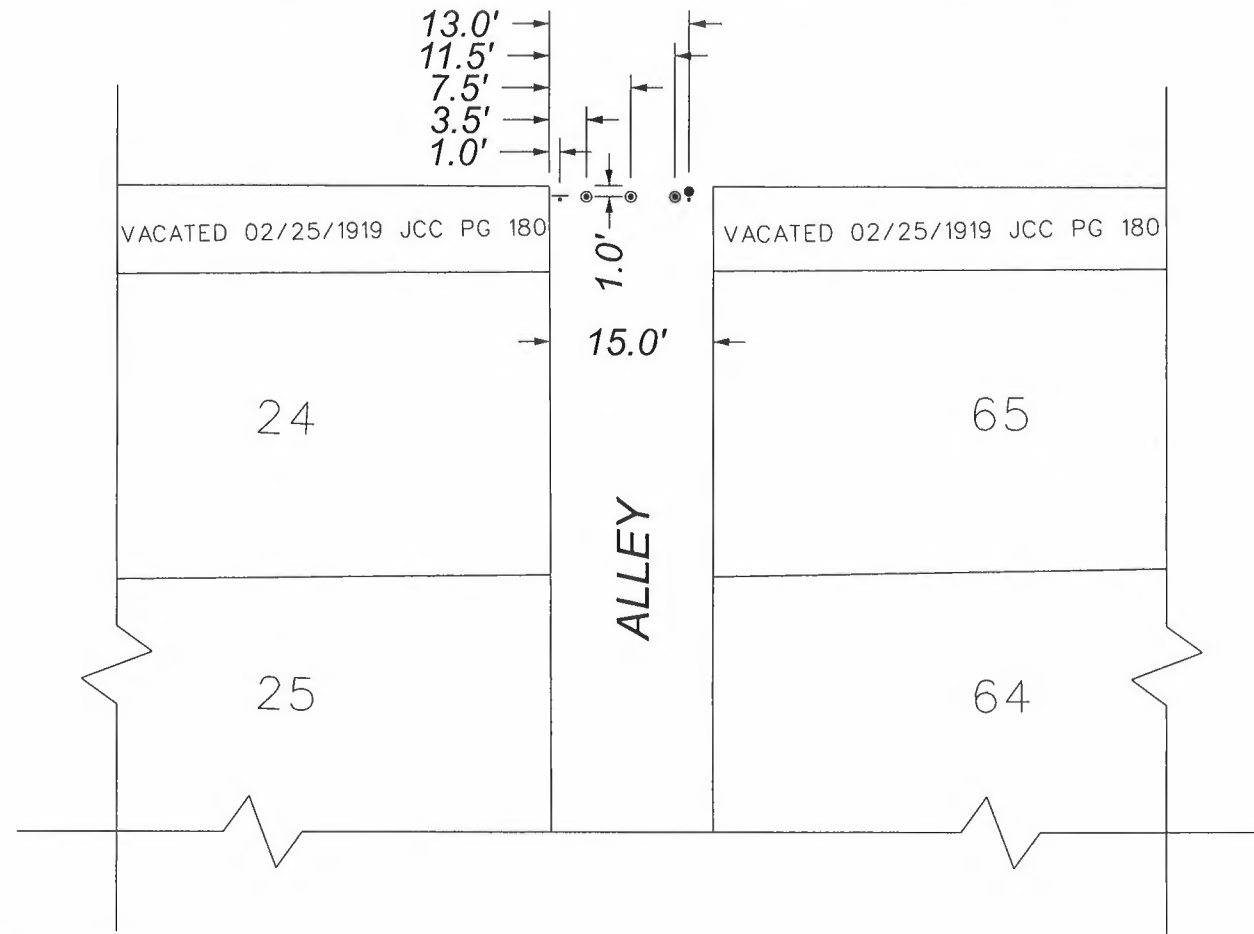

WESTMINSTER AVE.

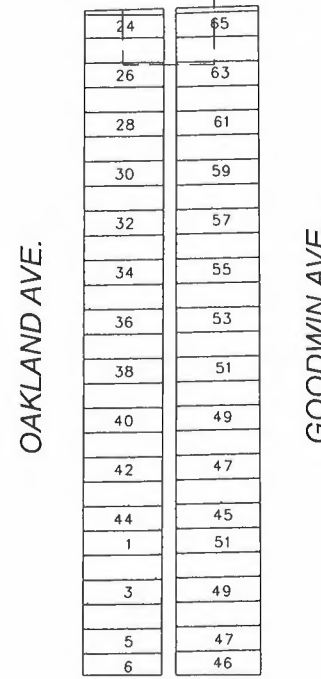

OWEN AVE.

- - PET WASTE STATION (IN-GROUND)
- - ARTS ALLEY STANDARD SIGN (SURFACE MOUNT)
- ⊙ - CAST IRON DECORATIVE BOLLARD (SURFACE MOUNT - REMOVABLE)

(FOR OFFICE USE ONLY)

CARTO 42 C / 42 D

| B | | | | | |
|-------------|------------|----------|-------|------|--|
| A | | | | | |
| DESCRIPTION | DRWN | CHKD | APPD | DATE | |
| REVISIONS | | | | | |
| DRAWN BY | TS | CHECKED | AP/LC | | |
| DATE | 05-30-2024 | APPROVED | RW | | |

REQUEST ENCROACHMENT INTO
THE NORTH/SOUTH ALLEY, 15 FT. WD.
IN THE BLOCK BOUNDED BY
GOODWIN AVE., OWEN AVE., OAKLAND AVE.,
AND WESTMINSTER AVE.

CITY OF DETROIT
CITY ENGINEERING DIVISION
SURVEY BUREAU

JOB NO. 24-17

DRWG. NO. 04