



CITY OF DETROIT
DEPARTMENT OF PUBLIC WORKS
CITY ENGINEERING DIVISION

COLEMAN A. YOUNG MUNICIPAL CENTER
2 WOODWARD AVE. SUITE 601
DETROIT, MICHIGAN 48226
PHONE: (313) 224-3949 • TTY: 711
FAX: (313) 224-3471
WWW.DETROITMI.GOV

October 11th, 2023

Honorable City Council:

RE: Petition Number x2023-345 Joseph Zainea, request for the temporary closure of a public alley located adjacent to 4104 Woodward Avenue, for a period of five (5) years.

Petition Number x2023-345 Joseph Zainea, request for the temporary closure of a public alley, varied width, located easterly of and adjacent to 4104 Woodward Avenue, for a period of five (5) years.

The petition was referred to the City Engineering Division - DPW for investigation (utility clearance) and report. This is our report.

DTE Energy objected to the proposed petition. All other city departments and utilities have reported no objections to the temporary closure, provided that the right to 24-hour access is provided to their facilities. Provisions protecting the rights of the utilities and the City are a part of this resolution.

I am recommending adoption of the attached resolution.

Respectfully submitted,

Richard Doherty, P.E., City Engineer
City Engineering Division - DPW

Cc: Ron Brundidge, Director - DPW
Mayor's Office - City Council Liaison

BY COUNCIL MEMBER _____

RESOLVED, The City Engineering Division – DPW is hereby authorized and directed to issue permit for the temporary closure of the public right-of-way, further described as:

Public alley, varied width, lying easterly of and adjacent to part of lot 26 and 28, excluding the southerly 50.32 ft. of lot 26, of the “Plat of Park Lots” as recorded in Liber 34, Page 542 of Plats, Wayne County Records, lying east of Woodward Avenue, 120 ft. wide, between Willis Avenue, 100 ft. wide, and Alexandrine Avenue, 120 ft. wide, and that part of the public alley lying northerly of and adjacent to lots 22 through 25 of the “Med Center Urban Renewal Plat No. 2” as recorded in Liber 90, Page 89-91 of Plats, Wayne County Records.

PROVIDED, That the petitioner shall file with the Finance Department and/or City Engineering Division – DPW an indemnity agreement in the form approved by the Law Department. The agreement shall save and protect the City of Detroit from all claims, damages or expenses that may arise by reason of the issuance of permits and the faithful or unfaithful performance by the petitioner of the terms thereof. Further, the petitioner shall agree to pay all claims, damages or expenses that may arise out of the maintenance of the temporary public street closing; and

PROVIDED, the property owned by the petitioner and adjoining the temporary public street closing shall be subject to the proper zoning or regulated use (Board of Zoning Appeals Grant) over the total width and length of the street; and

PROVIDED, No building or other structures of any nature whatsoever, including, but not limited to, concrete slabs or driveways, retaining or partition walls, line fences or gates, shall be constructed on or over the public right of way. The petitioner shall observe the rules and regulations of the City Engineering Division – DPW. The City of Detroit retains all rights and interests in the temporary closed public right of way. The City and all utility companies retain their rights to service, inspect, maintain, repair, install, remove or replace utilities in the temporary closed public rights of way. Further, the petitioner shall comply with all specific conditions imposed to ensure unimpeded 24 hour-per-day access to the City and utility companies; and

PROVIDED, This resolution does not permit the storage of materials, displays of merchandise or signs within the temporary closed public rights of way. Further, the placement of materials, merchandise, or signs on any adjacent temporary area is prohibited; and

PROVIDED, that if there is still a need for access from any of the abutting property owners to said temporary closed street, access shall and must be maintained for those properties; and

PROVIDED, that this resolution is revocable at the will, whim, or caprice of the Detroit City Council without cause. The petitioner waives the right to claim damages or compensation for removal of encroachments. Further, the permittee acquires no implied or other privileges hereunder not expressly stated herein. If this permit is continued for the five (5) year period, the City Council may (Upon written request and if the circumstances justify accordingly) grant an extension thereto; and

PROVIDED, that the 5-year period for the temporary closure shall begin on the date City Council approves this resolution; and further

PROVIDED, that this permit shall not be assigned or transferred without the written approval of the Detroit City Council; and further

PROVIDED, That the City Clerk shall within 30 days record a certified copy of this resolution with the Wayne County Register of Deeds.

MAP-23-115

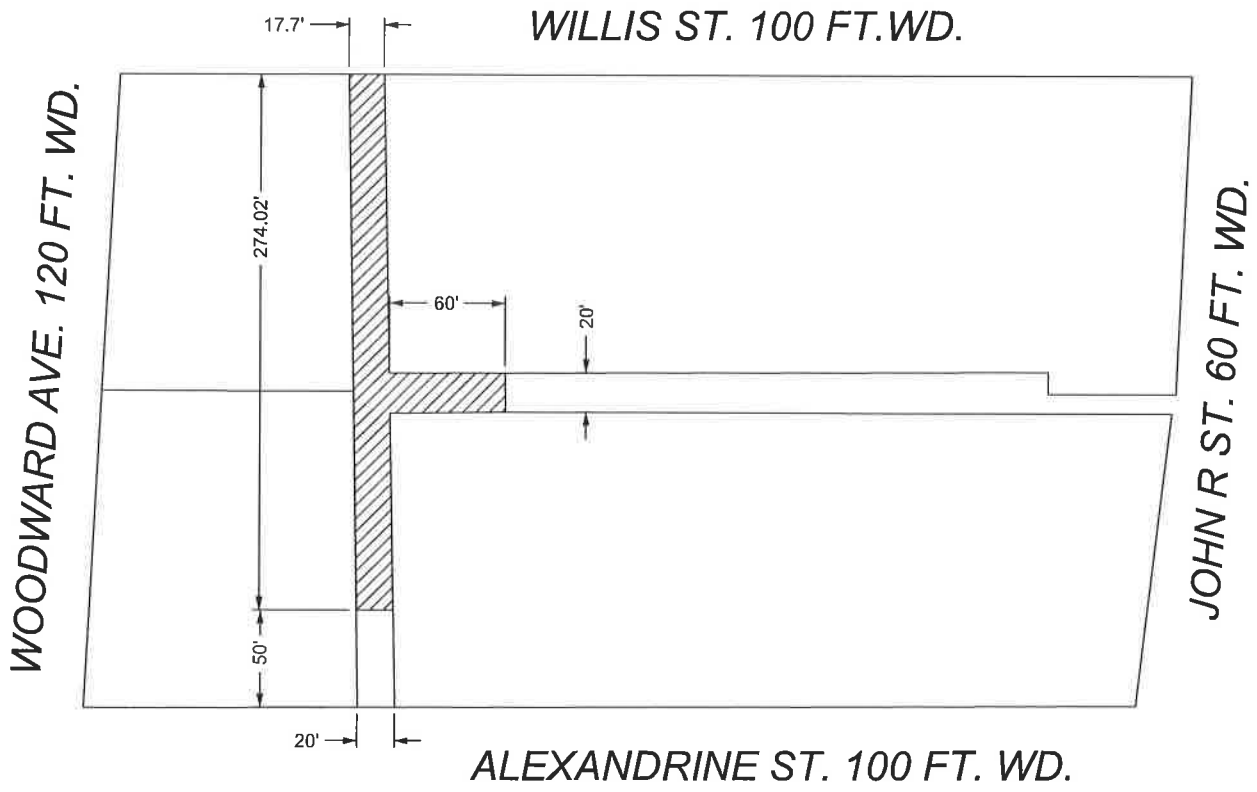

 - RENEWAL OF TEMPORARY ALLEY CLOSURE

(FOR OFFICE USE ONLY)

CARTO 30 F

B						RENEWAL OF TEMPORARY CLOSURE OF THE NORTH/SOUTH ALLEY BETWEEN E. ALEXANDRINE ST. AND WILLIS AVE., AND THE WEST 60 FT. PORTION OF THE WEST/EAST ALLEY BETWEEN WOODWARD AVE. AND JOHN R ST.	CITY OF DETROIT CITY ENGINEERING DIVISION SURVEY BUREAU
	A						
DESCRIPTION		DRWN	CHKD	APPD	DATE	JOB NO. 23-115	DRWG. NO.
DRAWN BY LC		CHECKED AP					
DATE 10-17-2023		APPROVED JD					