

Janice M. Winfrey  
City Clerk

**City of Detroit**  
OFFICE OF THE CITY CLERK

Andre P. Gilbert II  
Deputy City Clerk

**DEPARTMENT PETITION REFERENCE COMMUNICATION**

*To: The Department or Commission Listed Below*

*From: Janice M Winfrey, Detroit City Clerk*

---

The following petition is herewith referred to you for report and recommendation to the City Council.

In accordance with that body's directive, kindly return the same with your report in duplicate within four (4) weeks.

---

Petition No.	2023-341
Name of Petitioner	Peterboro Investment LLC
Description of Petition	Petition for the encroachment within the northerly part of Peterboro Street, adjacent to the parcel commonly known as 444 Peterboro Street, for the purposes of installing awnings, planters, and non-standard paving.
Type of Petition	<b>Alley Vacation/Encroachment/Utility Vacation</b>
Submission Date	10/10/2023
Concerned Departments	Department of Public Works (DPW), Planning and Development Department, Department of Public Lighting, City Engineering Division
Petitioner Contact	Jered Dean Manager II Department of Public Works City Engineering Division (313) 224-3985 <a href="mailto:deanj@detroitmi.gov">deanj@detroitmi.gov</a>



**CITY OF DETROIT  
DEPARTMENT OF PUBLIC WORKS  
CITY ENGINEERING DIVISION**

**COLEMAN A. YOUNG MUNICIPAL CENTER  
2 WOODWARD AVE. SUITE 601  
DETROIT, MICHIGAN 48226  
PHONE: (313) 224-3949 TTY: 711  
WWW.DETROITMI.GOV**

---

To: Clerk's Office  
From: The Department of Public Works  
City Engineering Division  
MapsandRecordsBureau@DetroitMI.Gov  
(313) 224-3970

Petitioner:  
Peterboro Investments LLC  
458 Peterboro  
Detroit, MI, 48201

On behalf of the above-mentioned petitioner the Department of Public Works: City Engineering Division is submitting a petition request for the below mentioned action. The petitioner has received a project consultation from the Department of Public Works: City Engineering Division and has been advised the following:

Type of action recommended:

Petition for encroachment within the northerly part of Peterboro Street, adjacent to the parcel commonly known as 444 Peterboro Street, for the purpose of installing awnings, planters, and non-standard paving.

Jered Dean  
Manager II  
Department of Public Works  
City Engineering Division  
313-224-3985



Ronnisch Construction Group  
4327 Delemere Court  
Royal Oak, MI 48073

August 3, 2023

**City of Detroit Right of Way Management  
Department of Public Works - Maps and Records Bureau  
313-224-3970**

**RE: 444 Peterboro Encroachment Petition ENG-23-942**

To Whom it May Concern:

Ronnisch Construction Group, LLC, on behalf of 444 Peterboro, LLC, is submitting the following letter of intent for the encroachment petition involving the awning, planters, and pavers located at 444 Peterboro (formerly known as 458 Peterboro), Detroit MI, 48201. The site plan (attached) calls for the following streetscape items to be reviewed and approved along Peterboro street:

**Awning:** Located at +/-11'0" above finished floor (A.F.F)

Height: 3'0"

Width: 55'0"

Depth: 5'8"

**Planters:**

Height: 19"

Width: 7'6"

Depth: 7'6"

**Pavers:**

Height: flat – flush with sidewalk

Width: 100'0" (length of building)

Depth: 16'9"

Thank you for your time and consideration in our proposal for this project. Please direct any questions or concerns directly to Victoria Oldfield at [voldfield@ronnisch.com](mailto:voldfield@ronnisch.com) or at 586-246-8089.

Sincerely,

A handwritten signature in blue ink, appearing to be 'Victoria Oldfield', is written over a faint, larger signature or stamp.

Victoria Oldfield  
Project Engineer  
Ronnisch Construction Group, LLC





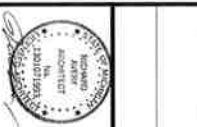

**DO NOT REPRODUCE**  
 This document contains confidential information and is intended for the use of the recipient only. It shall not be used or other proceeds for any other purpose without the express written approval of the architect's design firm.

**ISSUE FOR PERMIT**  
**A12**

**PETERBORO HOTEL**  
 444 PETERBORO ST, DETROIT, MI 48201

**4 LANDSCAPING CALLOUT AT STREET ENTRY**

LANDSCAPING CALLOUT AT STREET ENTRY

**4 ENLARGED PLAN - TRASH ENCLOSURE**

ENLARGED PLAN - TRASH ENCLOSURE

**7 ACCESSIBLE PARKING ISLE STRIPING**

ACCESSIBLE PARKING ISLE STRIPING

**6 LANDSCAPING CALLOUT AT NORTH ALLEY**

LANDSCAPING CALLOUT AT NORTH ALLEY

**5 LANDSCAPING CALLOUT AT PARKING APRON**

LANDSCAPING CALLOUT AT PARKING APRON

**3 SECTION - TRASH ENCLOSURE**

SECTION - TRASH ENCLOSURE

**2 ELEVATION - TRASH ENCLOSURE (EAST)**

ELEVATION - TRASH ENCLOSURE (EAST)

**1**





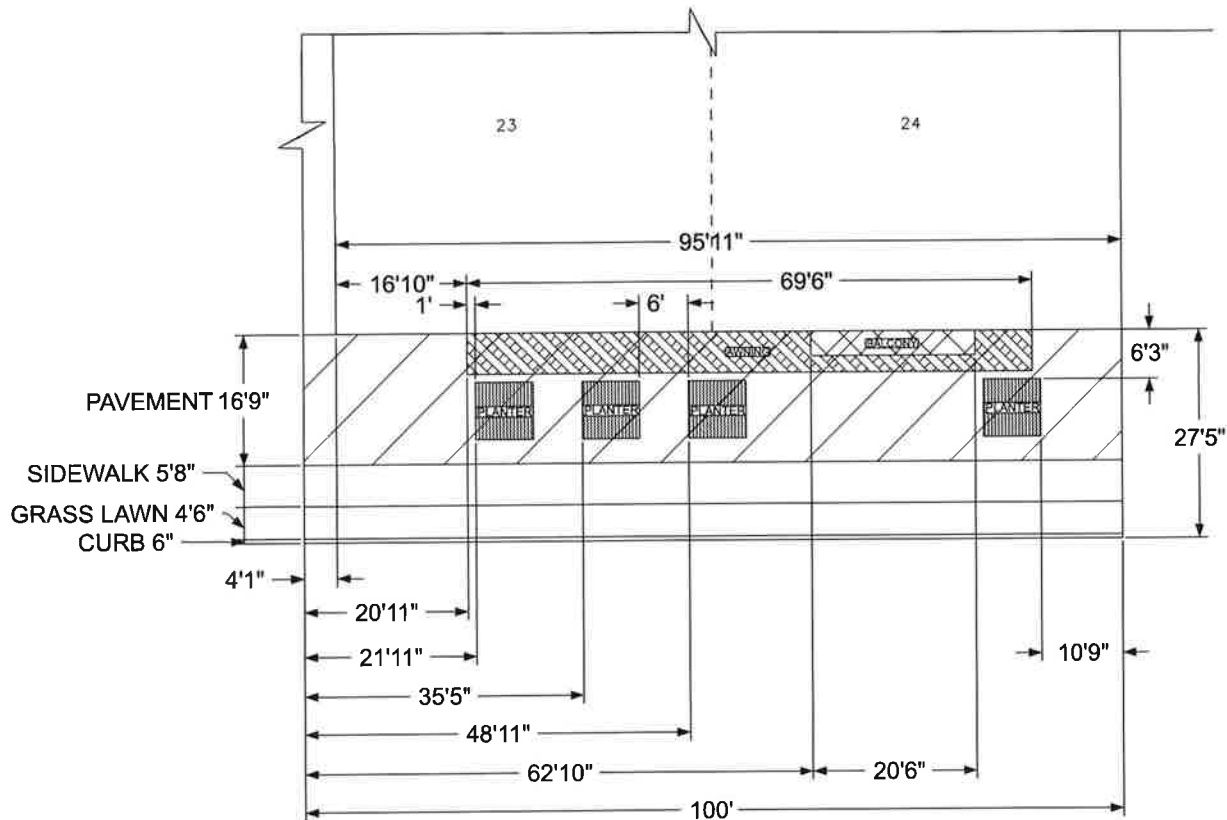

PUBLIC ALLEY 20 FT. WD.

SECOND BLVD. 100 FT. WD.

PUBLIC ALLEY 20 FT. WD.



PETERBORO 100 FT. WD.

-  - 20'6" X 3'8" BALCONY AT 4TH FLOOR
-  - 69'6" X 5'0" AWNING AT 10'6" ABOVE FINISHED FLOOR
-  - 4 PLANTERS (7'6"L X 7'6"W X 19"H)
-  - REQUEST ENCROACHMENT (balcony, awning, planters, and 100' X 16'9" pavement)

(FOR OFFICE USE ONLY)

MARTIN LUTHER KING JR. BLVD. 100 FT. WD.



PETERBORO 100 FT. WD.

CARTO 29B

B					
A					
DESCRIPTION	DRWN	CHKD	APPD	DATE	
REVISIONS					
DRAWN BY	SR	CHECKED	LC		
DATE	08-25-2023	APPROVED	JD		

REQUEST ENCROACHMENT  
 PETERBORO ST.  
 AT 444 PETERBORO ST.  
 (with balcony, awning, planters, and pavers)

CITY OF DETROIT CITY ENGINEERING DIVISION SURVEY BUREAU	
JOB NO.	23-109
DRWG. NO.	