

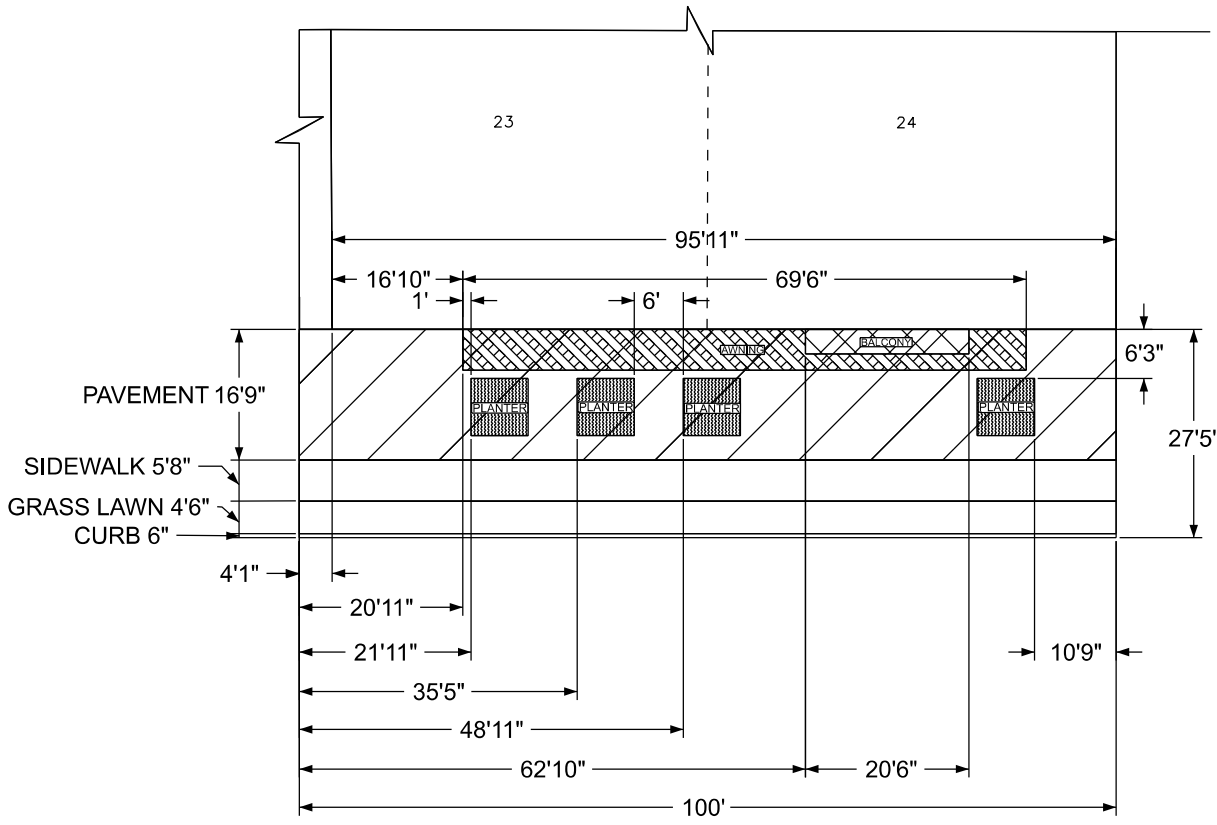

SECOND BLVD. 100 FT. WD.

PUBLIC ALLEY 20 FT. WD.

PUBLIC ALLEY 20 FT. WD.



PETERBORO 100 FT. WD.

- 20'6" X 3'8" BALCONY AT 4TH FLOOR
- 69'6" X 5'0" AWNING AT 10'6" ABOVE FINISHED FLOOR
- 4 PLANTERS (7'6"L X 7'6"W X 19"H)
- REQUEST ENCROACHMENT (balcony, awning, planters, and 100' X 16'9" pavement)

(FOR OFFICE USE ONLY)

MARTIN LUTHER KING JR. BLVD. 100 FT. WD.

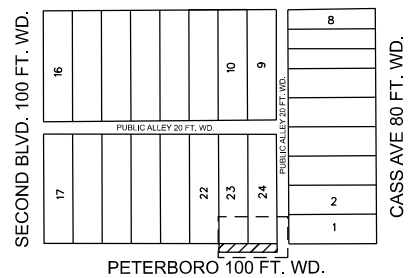

PETERBORO 100 FT. WD.

CARTO 29B

B					
A					
DESCRIPTION	DRWN	CHKD	APPD	DATE	
REVISIONS					
DRAWN BY	SR	CHECKED	LC		
DATE	08-25-2023	APPROVED	JD		

REQUEST ENCROACHMENT  
PETERBORO ST.  
AT 444 PETERBORO ST.  
(with balcony, awning, planters, and pavers)

<b>CITY OF DETROIT</b>	
CITY ENGINEERING DIVISION	
SURVEY BUREAU	
JOB NO.	23-109
DRWG. NO.	