

YELLOW DENOTES  
AREA OF VACATING

SCALE: 1" = 50'

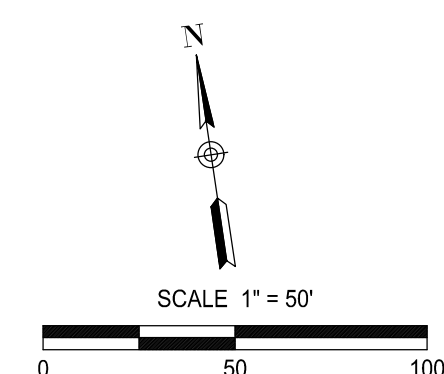

DRAWING NUMBER <b>C1.5-1</b>	PROJECT NUMBER 1942-6994-50	DATE	NO.	REVISION	PROJECT IS SUBJECT TO BUY AMERICA REQUIREMENTS
			0	DESIGN DEVELOPMENT	
DRAWN: RFP DESIGNED: RNS APPROVED: DATE:	PROJECT NUMBER 1942-6994-50	DATE	NOT FOR CONSTRUCTION		
			DDOT COOLIDGE OPERATIONS AND MAINTENANCE FACILITY		
SITE PLAN - AREAS OF VACATING		ARCHITECTURE • ENGINEERING • PLANNING SURVEYING • CONSTRUCTION SERVICES DLZ DETROIT, MICHIGAN, INC.			