



CITY OF DETROIT
DEPARTMENT OF PUBLIC WORKS
CITY ENGINEERING DIVISION

COLEMAN A. YOUNG MUNICIPAL CENTER
2 WOODWARD AVE. SUITE 601
DETROIT, MICHIGAN 48226
PHONE: (313) 224-3949 • TTY:711
FAX: (313) 224-3471
WWW.DETROITMI.GOV

January 27th, 2022

Honorable City Council:

RE: Petition No. x2022-8 – Liv Holdings LLC, request encroachment into Livernois Avenue for various building façade features at 18999 – 19011 Livernois Avenue.

Petition No. x2022-8 Liv Holdings LLC, request encroachment into Livernois Avenue, 120 ft. wide, for various building façade features at 18999 – 19011 Livernois Avenue.

The petition was referred to the City Engineering Division – DPW for investigation and report. This is our report.

This request is being made to approve existing building features within Livernois Avenue at 18999-19011 Livernois Avenue.

The request was approved by the Solid Waste Division – DPW, and City Engineering Division – DPW. The request was approved by the Traffic Engineering Division – DPW.

Detroit Water and Sewerage Department (DWSD) reports being involved, but they have no objection provided the DWSD encroachment provisions are followed. The DWSD provisions have been made a part of the resolution. DTE has reported involvement and provisions protecting DTE have been made a part of the resolution.

All other involved City Departments, including the Public Lighting Authority and Public Lighting Department; also privately owned utility companies have reported no objections to the encroachment. Provisions protecting all utility installations are part of the attached resolution.

I am recommending adoption of the attached resolution.

Respectfully submitted,

Richard Doherty, P.E., City Engineer
City Engineering Division – DPW

JMK/SW

Cc: Ron Brundidge, Director, DPW
Mayor's Office – City Council Liaison

COUNCIL MEMBER _____

RESOLVED, that the Department of Public Works, City Engineering Division is hereby authorized and directed to issue permits to Liv Holdings LLC or their assigns to install and maintain encroachment for the following:

1. Canopy; located easterly and adjacent to lots 256 and 257 of "Canterbury Gardens Subdivision" as recorded in Liber 37, Page 65 of Plats, Wayne County Records. Said canopy will encroach by 8' at its southerly point for 29'; being 11'-2" above grade at its base and 15' at the peak.
2. Onsite Advertising Sign; located easterly and adjacent to lot 258 of "Canterbury Gardens Subdivision" as recorded in Liber 37, Page 65 of Plats, Wayne County Records. Said Onsite Advertising Sign will encroach by 7'; being 20' above grade at its base and 25' at the peak.
3. Canopy; located easterly and adjacent to lots 259 and 260 of "Canterbury Gardens Subdivision" as recorded in Liber 37, Page 65 of Plats, Wayne County Records. Said canopy will encroach by 25" for 20'; being 11' 2" above grade at its base and 15' 4" at the peak.
4. Lighting features, located easterly and adjacent to lots 259 and 260 of "Canterbury Gardens Subdivision" as recorded in Liber 37, Page 65 of Plats, Wayne County Records. Said Lighting features to encroach no more than 25" at 16' above grade.

PROVIDED, that if there is any cost for the removing and/or rerouting of any utility facilities, it shall be done at the expense of the petitioner and/or property owner; and be it further

PROVIDED, that access is maintained to all fire department connections, and be it further

PROVIDED, that by approval of this petition the Detroit Water and Sewerage Department (DWSD) does not waive any of its rights to its facilities located in the right-of-way, and at all times, DWSD, its agents or employees, shall have the right to enter upon the right-of-way to maintain, repair, alter, service, inspect, or install its facilities. All costs incident to the damaging, dismantling, demolishing, removal and replacement of structures or other improvements herein permitted and incurred in gaining access to DWSD's facilities for maintenance, repairing, alteration, servicing or inspection caused by the encroachment shall be borne by the petitioner. All costs associated with gaining access to DWSD's facilities, which could normally be expected had the petitioner not encroached into the right-of-way, shall be borne by DWSD; and be it further

PROVIDED, that the necessary permits shall be obtained from the City Engineering Division – DPW and the Buildings and Safety Engineering Department. The encroachments shall be constructed and maintained under their rules and regulations; and further

PROVIDED, that all cost for the construction, maintenance, permits and use of the encroachments shall be borne by Liv Holdings LLC or their assigns, and further

PROVIDED, that the Liv Holdings LLC or their assigns provide as-built drawings of their installation and the relationship to other utility infrastructure to the Department of Public Works – City Engineering Division, and further

PROVIDED, that all costs incurred by privately owned utility companies and/or city departments to alter, adjust, and/or relocate their existing utility facilities located in close proximity to the encroachments shall be borne by Liv Holdings LLC or their assigns. Should damages to utilities occur

Liv Holdings LLC or their assigns shall be liable for all incidental repair costs and waives all claims for damages to the encroaching installations; and further

PROVIDED, that no other rights in the public streets, alleys or other public place shall be considered waived by this permission which is granted expressly on the condition that said encroachments shall be removed at any time when so directed by the City Council, and the public property affected shall be restored to a condition satisfactory to the City Engineering Division – DPW; and further

PROVIDED, that Liv Holdings LLC or their assigns shall file with the Department of Public Works – City Engineering Division an indemnity agreement in form approved by the Law Department. The agreement shall save and protect the City of Detroit from any and all claims, damages or expenses that may arise by reason of the issuance of the permits and the faithful or unfaithful performance of Liv Holdings LLC or their assigns of the terms thereof. Further, Liv Holdings LLC or their assigns shall agree to pay all claims, damages or expenses that may arise out of the use, repair and maintenance of the proposed encroachments; and further

PROVIDED, that all cost for the construction, maintenance, permits and use of the encroachments shall be borne by Liv Holdings LLC, or their assigns; and further

PROVIDED, that construction of the encroachments shall constitute acceptance of the terms and conditions as set forth in this resolution; and be it further

PROVIDED, this resolution or part thereof is revocable at the will, whim or caprice of the City Council, and Liv Holdings LLC acquires no implied or other privileges hereunder not expressly stated herein; and further

PROVIDED, that the encroachment permits shall not be assigned or transferred without the written approval of the City Council; and be it further

PROVIDED, that the City Clerk shall within 30 days record a certified copy of this resolution with the Wayne County Register of Deeds.

Petition x2022-8
 MAP-21-52



7 MILE ROAD 86 FT. WD.



CLARITA AVE. 50 FT. WD.

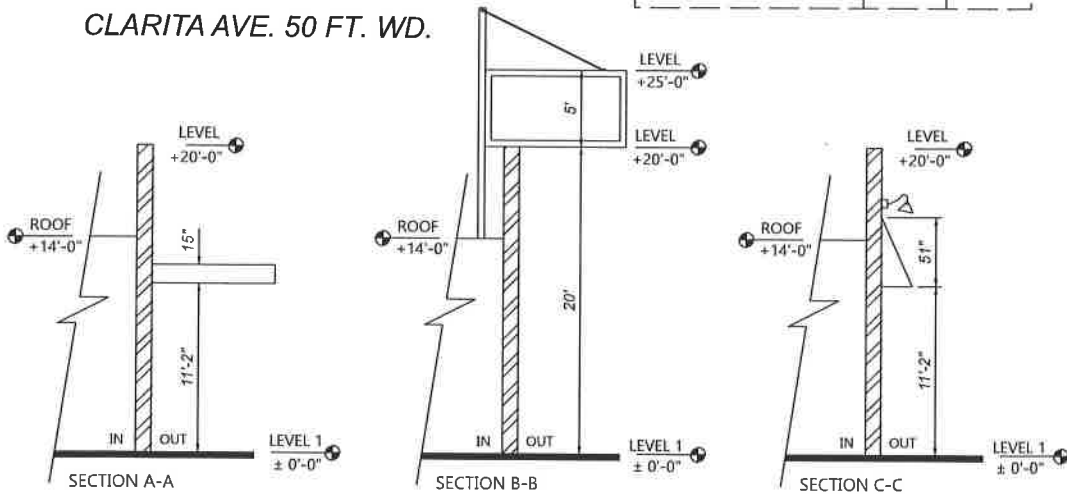

■ - REQUEST ENCROACHMENT

(FOR OFFICE USE ONLY)

CARTO 89 A

B					
A					
DESCRIPTION		DRWN	CHKD	APPD	DATE
REVISIONS					
DRAWN BY	SA	CHECKED		JD	
DATE	10-15-2021	APPROVED			

REQUEST ENCROACHMENT
 INTO LIVERNOIS AVE.
 AT 19011 LIVERNOIS

CITY OF DETROIT
 CITY ENGINEERING DIVISION
 SURVEY BUREAU

JOB NO. 01-01

DRWG. NO.