



- - - ROW BOUNDARY
 - - - EX LOT LINE
 - - - BUILDING OUTLINE
 ENCROACHMENT RESERVATION
 AT GRADE ENCROACHMENT

giffels 
webster

 **EX-100 ALLEY ENCROACHMENT EXHIBIT**

PROJECT INFORMATION:
 BOOK DEVELOPMENT
 19574-00D



THE PROJECT IS LOCATED ON THE BLOCK BOUND BY STATE ST., WASHINGTON BLVD., AND GRAND RIVER AVE.

THE PLANS ABOVE INCLUDE PROPOSED AT GRADE ENCROACHMENTS FOR LANDSCAPE FEATURES IN THE ALLEY WAY.

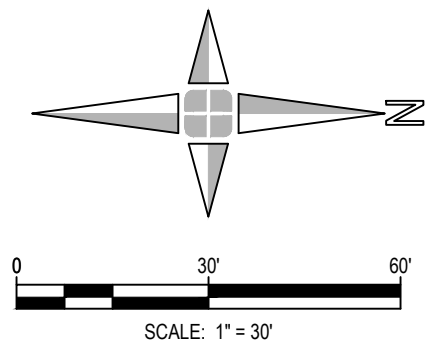
ENCROACHMENT EXHIBIT PREPARED BY:
 DANIELLE DIEHL
 313.285.5241
 03-13-2023

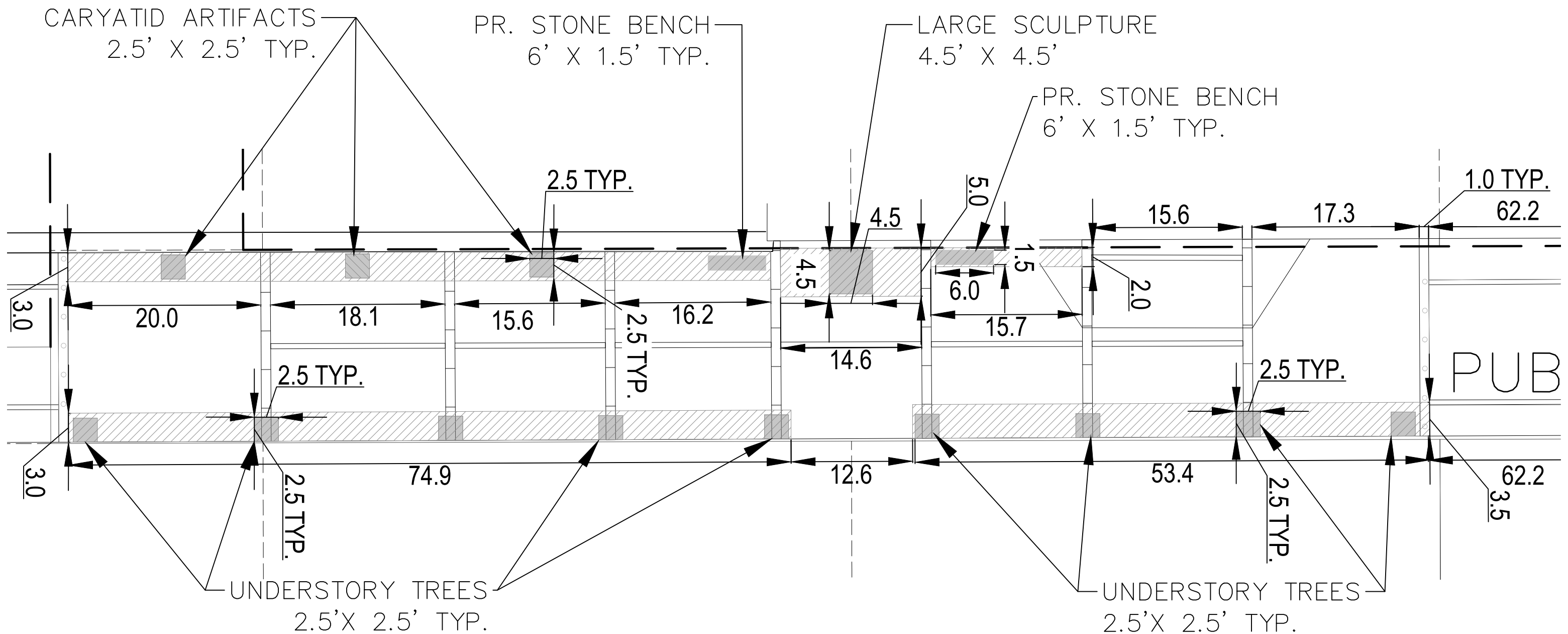



- - - ROW BOUNDARY
 - - - EX LOT LINE
 - - - BUILDING OUTLINE
 ENCROACHMENT RESERVATION
 AT GRADE ENCROACHMENT



EX-101 ALLEY ENCROACHMENT EXHIBIT

PROJECT INFORMATION:
 BOOK DEVELOPMENT
 19574-00D

THE PROJECT IS LOCATED ON THE BLOCK BOUND
 BY STATE ST., WASHINGTON BLVD., AND GRAND
 RIVER AVE.

THE PLANS ABOVE INCLUDE PROPOSED AT
 GRADE ENCROACHMENTS FOR LANDSCAPE
 FEATURES IN THE ALLEY WAY.

ENCROACHMENT EXHIBIT PREPARED BY:
 DANIELLE DIEHL
 313.285.5241
 03-13-2023

