



CITY OF DETROIT
DEPARTMENT OF PUBLIC WORKS
CITY ENGINEERING DIVISION

COLEMAN A. YOUNG MUNICIPAL CENTER
2 WOODWARD AVE. SUITE 601
DETROIT, MICHIGAN 48226
PHONE: (313) 224-3949 • TTY: 711
FAX: (313) 224-3471
WWW.DETROITMI.GOV

January 27th, 2022

Honorable City Council:

RE: Petition No. x2022-35 – DTE Energy, request for the outright vacation of Western Street located between Sharon Street and Weir Street, south of McGraw Street.

Petition No. x2022-35 – DTE Energy, request for the outright vacation of Western Street, 50 ft. wide, located between Sharon Street, 50 ft. wide, and Weir Street, 50 ft. wide, south of McGraw Street 66ft. wide.

The petition was referred to the City Engineering Division – DPW for investigation (utility review) and report. This is our report.

The request is made as part of a consolidation of property by DTE Energy.

The request was approved by the Solid Waste Division – DPW, and Traffic Engineering Division – DPW, and City Engineering - DPW.

Detroit Water and Sewerage Department (DWSD) has no objection provided certain provisions are met. The DWSD provisions are a part of the attached resolution.

All other involved City Departments, and privately owned utility companies have reported no objections. Provisions protecting utility installations are part of the attached resolution.

I am recommending adoption of the attached resolution.

Respectfully submitted,



Richard Doherty, P.E., City Engineer
City Engineering Division – DPW

/JK

Cc: Ron Brundidge, Director, DPW
Mayor's Office – City Council Liaison

BY COUNCIL MEMBER _____

RESOLVED, Western Street, 50 ft. wide, located between Sharon Street, 50 ft. wide, and Weir Street, 50 ft. wide, south of McGraw Street 66 ft. wide; further described as land in the City of Detroit, Wayne County, Michigan being: Western Street, 50 ft. wide, lying westerly of and adjacent to lots 71 through 74 of “Sullivan & Russell’s Subdivision” as recorded in Liber 14, Page 91 of Plats, Wayne County Records.

Be and the same are hereby vacated (outright) as public rights-of-way to become part and parcel of the abutting property, subject to the following provisions:

PROVIDED, that petitioner/property owner make satisfactory arrangements with any and all utility companies for cost and arrangements for the removing and/or relocating of the utility companies and city departments services, and further

PROVIDED, that the petitioner/property owner acknowledge that DWSD relinquishes all responsibility for underground sewers, if any, and further

PROVIDED, that the petitioner/property owner bear the entire cost of any modification to the sewer, in any, including costs related to construction, demolition, permitting, inspection, and survey, and further

PROVIDED, that any construction in the public rights-of-way such as curbs and sidewalks shall be done under city permit and inspection according to City Engineering Division – DPW specifications with all costs borne by the abutting owner(s), their heir or assigns; and further

PROVIDED, That the City Clerk shall within 30 days record a certified copy of this resolution with the Wayne County Register of Deeds.

PETITION x2022-35
MAP-21-79

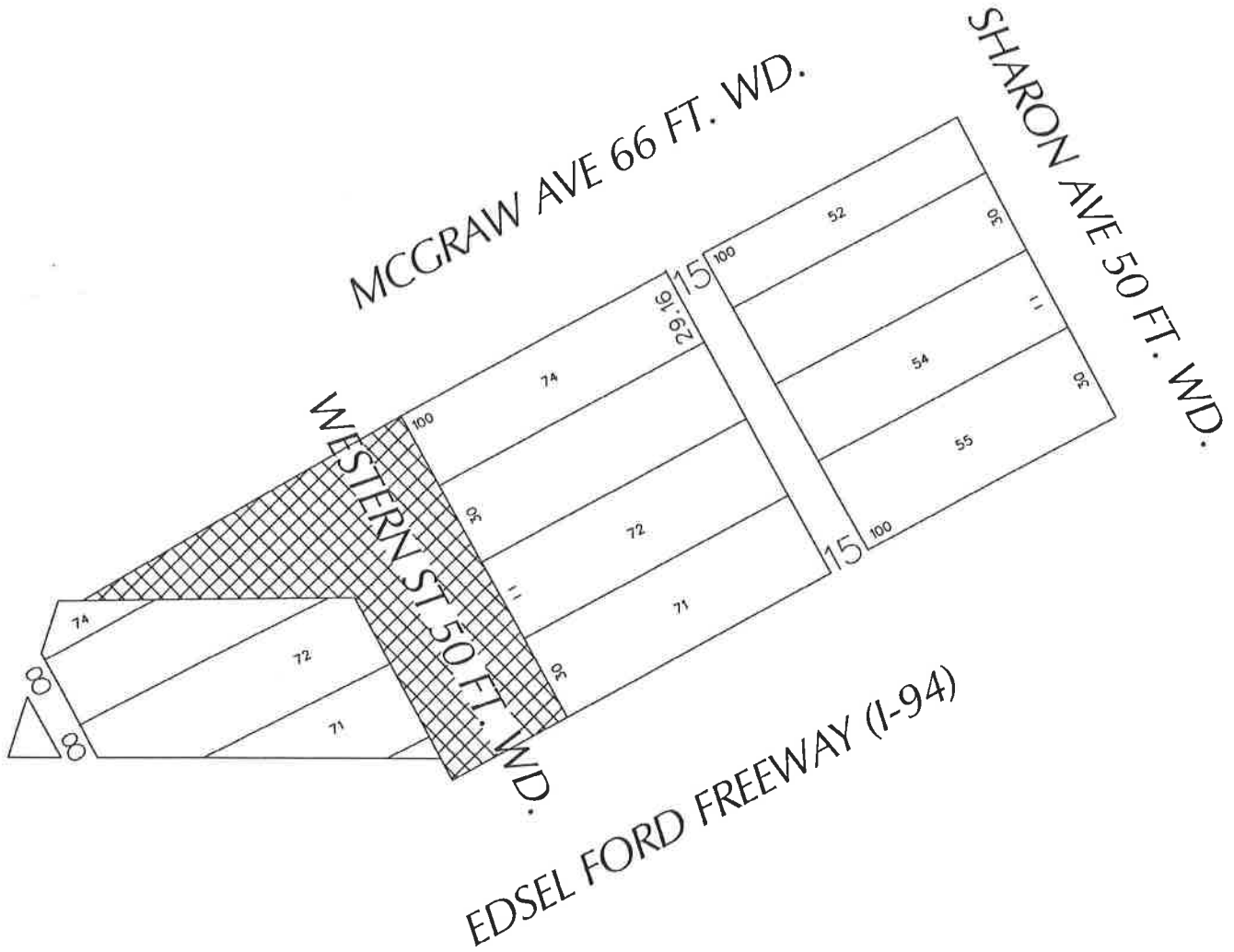

 - OUTRIGHT VACATION

(FOR OFFICE USE ONLY)

CARTO 4 B

B					
A					
DESCRIPTION	DRWN	CHKD	APPD	DATE	
REVISIONS					
DRAWN BY	KJ		CHECKED		
DATE	12-16-21		APPROVED	JD	

REQUEST FOR OUTRIGHT VACATION -
PORTION OF WESTERN ST AND
MCGRAW ST TO BE OUTRIGHT
VACATED FOR MCGRAW SUBSTATION
EXPANSION AT 9125 MCGRAW AVE

CITY OF DETROIT	
CITY ENGINEERING DIVISION	
SURVEY BUREAU	
JOB NO.	01-01
DRWG. NO.	