



**DEPARTMENT OF PUBLIC  
WORKS**

Coleman A. Young Municipal Center  
2 Woodward, Suite 601  
Detroit, Michigan 48226

Phone 313•224•3949 TTY: 711  
Fax 313•224•3471  
www.detroitmi.gov

**Amended**

August 10, 2024

Honorable City Council:

**RE: Petition No. 2022-33 – 18-24 West Adams LLC, request for encroachment of multiple awnings on the north side of West Adams Avenue, adjacent to 18-24 West Adams Avenue.**

Petition No. 2022-33 – 18-24 West Adams LLC, request for encroachment of multiple awnings on the north side of West Adams Avenue, 60 ft. wide, adjacent to 18-24 West Adams Avenue.

The petition was referred to the City Engineering Division – DPW for investigation and report. This is our report.

This request is being made to add shelter for the proposed outdoor café designed for the business at 18 West Adams Avenue.

The request was approved by the Solid Waste Division – DPW, and City Engineering Division – DPW. The request was approved by the Traffic Engineering Division – DPW.

Detroit Water and Sewerage Department (DWSD) reports being involved, but they have no objection provided the DWSD encroachment provisions are followed. The DWSD provisions have been made a part of the resolution. DTE has reported involvement and provisions protecting DTE have been made a part of the resolution.

All other involved City Departments, including the Public Lighting Authority and Public Lighting Department; also privately owned utility companies have reported no objections to the encroachment. Provisions protecting all utility installations are part of the attached resolution.

I am recommending adoption of the attached resolution.

Respectfully submitted,

Richard Doherty, P.E., City Engineer  
City Engineering Division – DPW

JMK/SW

Cc: Ron Brundidge, Director, DPW

Mayor's

Office

–

City

Council

Liaison

COUNCIL MEMBER \_\_\_\_\_

**RESOLVED**, that the Department of Public Works, City Engineering Division is hereby authorized and directed to issue permits to 18-24 WEST ADAMS LLC or their assigns to install and maintain encroachment for the following:

**Awnings**, located in three (3) positions on the north side of West Adams Avenue adjacent to lot 11 and lot 1 of the "Plat of Part of Park Lots" as recorded in Liber 7, Page 27 of Plats, Wayne County Records. Said awning being positioned between 47' and 127' west of the southeast corner of said lot 1 and shall be installed to extend 9' south of the property line. There will be 6.7' from the end of the awning to the back of the curb. Awnings to be installed at 8'-8" over grade at the awning base and 12'-8" at the peak of the awning. Awnings will be supported using a 4" x 4" stanchion and bolted at grade using an 8" x 8" x .5" plate.

PROVIDED, that if there is any cost for the removing and/or rerouting of any utility facilities, it shall be done at the expense of the petitioner and/or property owner; and be it further

PROVIDED, that access is maintained to all fire department connections, and be it further

PROVIDED, that by approval of this petition the Detroit Water and Sewerage Department (DWSD) does not waive any of its rights to its facilities located in the right-of-way, and at all times, DWSD, its agents or employees, shall have the right to enter upon the right-of-way to maintain, repair, alter, service, inspect, or install its facilities. All costs incident to the damaging, dismantling, demolishing, removal and replacement of structures or other improvements herein permitted and incurred in gaining access to DWSD's facilities for maintenance, repairing, alteration, servicing or inspection caused by the encroachment shall be borne by the petitioner. All costs associated with gaining access to DWSD's facilities, which could normally be expected had the petitioner not encroached into the right-of-way, shall be borne by DWSD; and be it further

PROVIDED, that the necessary permits shall be obtained from the City Engineering Division – DPW and the Buildings and Safety Engineering Department. The encroachments shall be constructed and maintained under their rules and regulations; and further

PROVIDED, that all cost for the construction, maintenance, permits and use of the encroachments shall be borne by 18-24 WEST ADAMS LLC or their assigns, and further

PROVIDED, that 18-24 WEST ADAMS LLC or their assigns provide as-built drawings of their installation and the relationship to other utility infrastructure to the Department of Public Works – City Engineering Division, and further

PROVIDED, that all costs incurred by privately owned utility companies and/or city departments to alter, adjust, and/or relocate their existing utility facilities located in close proximity to the encroachments shall be borne by 18-24 WEST ADAMS LLC or their assigns. Should damages to utilities occur 18-24 WEST ADAMS LLC or their assigns shall be liable for all incidental repair costs and waives all claims for damages to the encroaching installations; and further

PROVIDED, that no other rights in the public streets, alleys or other public place shall be considered waived by this permission which is granted expressly on the condition that said

encroachments shall be removed at any time when so directed by the City Council, and the public property affected shall be restored to a condition satisfactory to the City Engineering Division – DPW; and further

PROVIDED, that 18-24 WEST ADAMS LLC or their assigns shall file with the Department of Public Works – City Engineering Division an indemnity agreement in form approved by the Law Department. The agreement shall save and protect the City of Detroit from any and all claims, damages or expenses that may arise by reason of the issuance of the permits and the faithful or unfaithful performance of 18-24 WEST ADAMS LLC or their assigns of the terms thereof. Further, 18-24 WEST ADAMS LLC or their assigns shall agree to pay all claims, damages or expenses that may arise out of the use, repair and maintenance of the proposed encroachments; and further

PROVIDED, that all cost for the construction, maintenance, permits and use of the encroachments shall be borne by 18-24 WEST ADAMS LLC, or their assigns; and further

PROVIDED, that construction of the encroachments shall constitute acceptance of the terms and conditions as set forth in this resolution; and be it further

PROVIDED, this resolution or part thereof is revocable at the will, whim or caprice of the City Council, and 18-24 WEST ADAMS LLC acquires no implied or other privileges hereunder not expressly stated herein; and further

PROVIDED, that the encroachment permits shall not be assigned or transferred without the written approval of the City Council; and be it further

PROVIDED, that the City Clerk shall within 30 days record a certified copy of this resolution with the Wayne County Register of Deeds.

MAP-21-54

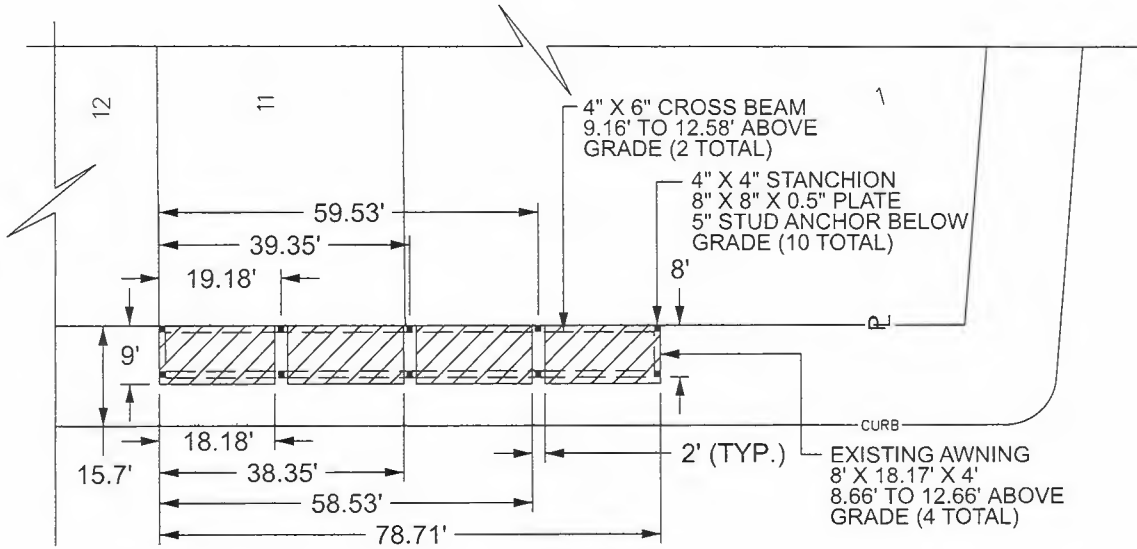

**WOODWARD AVE.  
120 FT. WD.**

**ADAMS AVE. 60 FT. WD.**

- REQUEST ENCROACHMENT (FOR TWO EXISTING CROSS BEAMS)
- REQUEST ENCROACHMENT (FOR TEN EXISTING STANCHIONS)
- REQUEST ENCROACHMENT (FOR FOUR EXISTING AWNINGS)

(FOR OFFICE USE ONLY)

PARK AVE. 60 FT. WD.

ELIZABETH ST. 60 FT. WD.

40	19	21	23	25	26	40	47.5	100.10	4	47.61
18	84	85	86	14	12	11	52.5	93.55	2	52.63
40	100	20	90	100	100	90	52.5	90.27	87	52.63

ADAMS AVE. 60 FT. WD.

WOODWARD AVE. 120 FT. WD.

CARTO 28 B

B					
A					
DESCRIPTION	DRWN	CHKD	APPD	DATE	
REVISIONS					
DRAWN BY	AP	CHECKED	LC		
DATE	09-18-2024	APPROVED	RW		

**REQUEST ENCROACHMENT  
INTO ADAMS AVE.  
AT 18 W. ADAMS AVE.**

**CITY OF DETROIT  
CITY ENGINEERING DIVISION  
SURVEY BUREAU**

JOB NO. 21-54

DRWG. NO.