

GLWA GPET 30-316 (x1318)

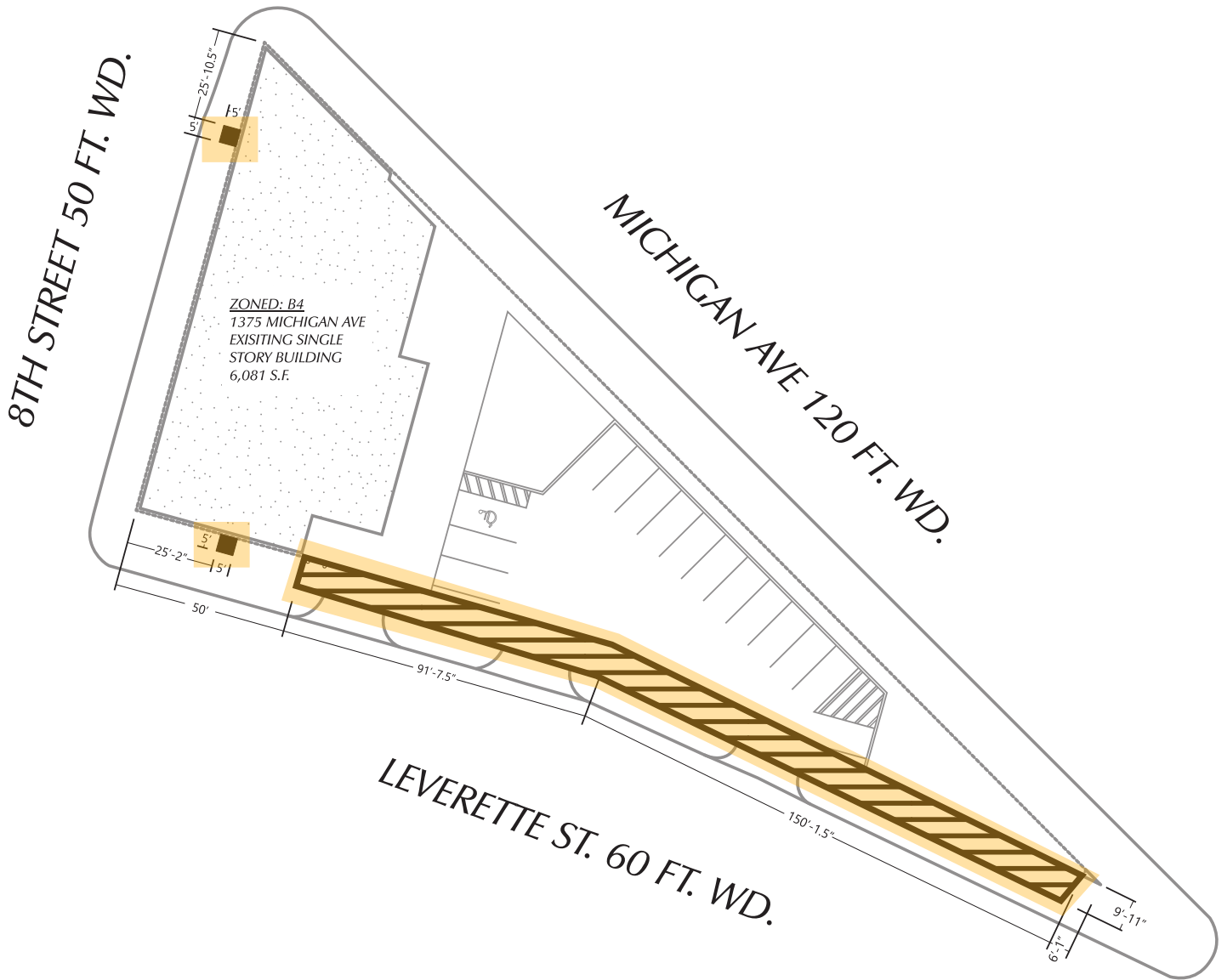

 PROPOSED AREA OF ENCROACHMENT
- FROM EXISTING FENCE LINE (EXISTING PAVING AND NEW LANDSCAPING)

(FOR OFFICE USE ONLY)

CARTO 28 C

B					
	A				
DESCRIPTION		DRWN	CHKD	APPD	DATE
REVISIONS					
DRAWN BY	KJ	CHECKED	KSM		
DATE	07-20-20	APPROVED BY	JD		

MULTIPLE ENCROACHMENTS AT 1331 MICHIGAN AVE., IN THE BLOCK BOUND BY MICHIGAN AVE., LEVERETTE AVE., AND 8TH STREET.

CITY OF DETROIT	
CITY ENGINEERING DIVISION	
SURVEY BUREAU	
JOB NO.	01-01
DRWG. NO.	X



MICHIGAN AVE 120 FT. WD.

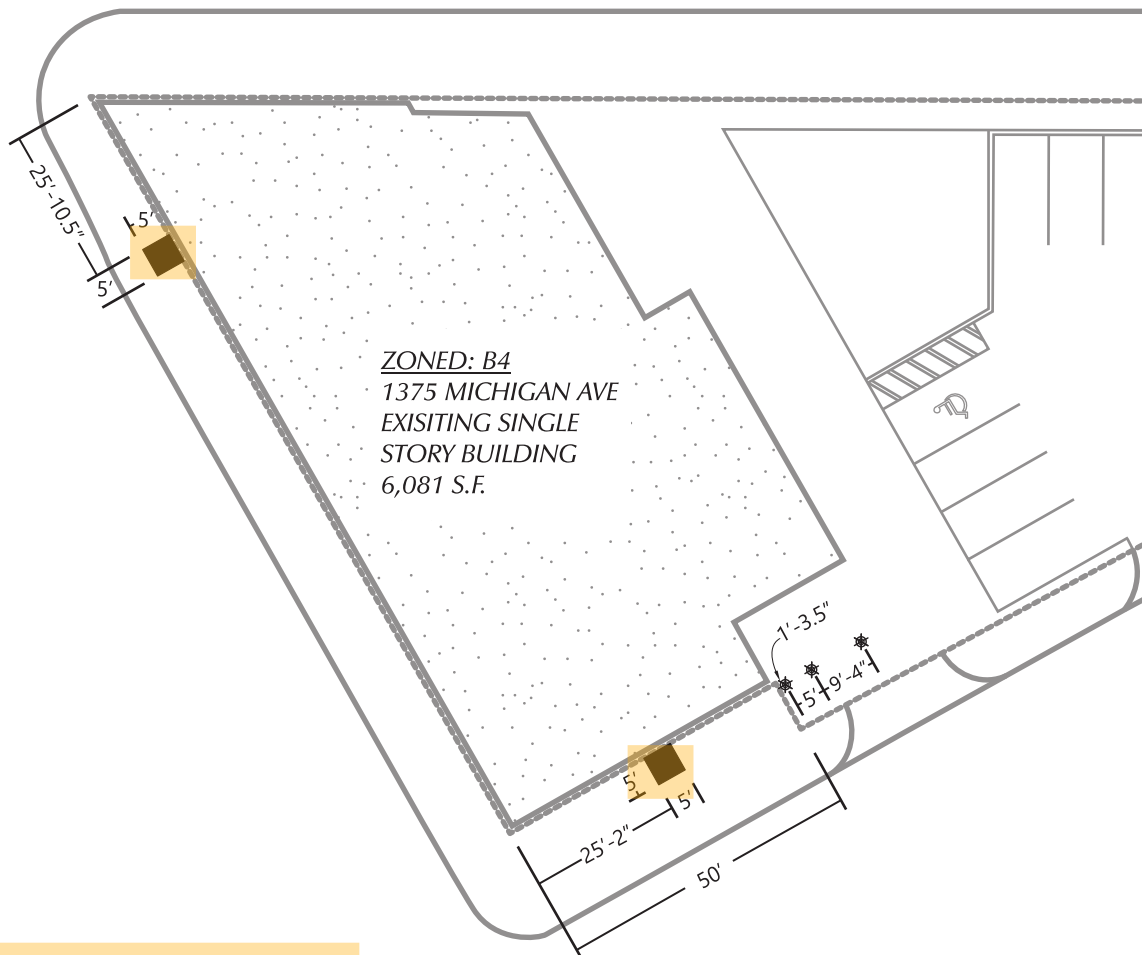

- 
 PROPOSED PAINTED STEEL
 – BOLLARDS WITH CONCRETE
 FOOTINGS AT NEW
 DUMPSTER ENCLOSURE

- 
 PROPOSED CONCRETE
 – MASS FOOTING AT NEW
 EXTERIOR WALL OPENING

(FOR OFFICE USE ONLY)

CARTO 28 C

B					
A					
DESCRIPTION	DRWN	CHKD	APPD	DATE	
REVISIONS					
DRAWN BY	KJ		CHECKED	KSM	
DATE	07-20-20		APPROVED BY	JD	

**MULTIPLE ENCROACHMENTS AT 1331
 MICHIGAN AVE., IN THE BLOCK
 BOUND BY MICHIGAN AVE., LEVERETTE
 AVE., AND 8TH STREET.**

CITY OF DETROIT	
CITY ENGINEERING DIVISION	
SURVEY BUREAU	
JOB NO.	01-02
DRWG. NO.	X

BOLLARD FOOTING SECTION

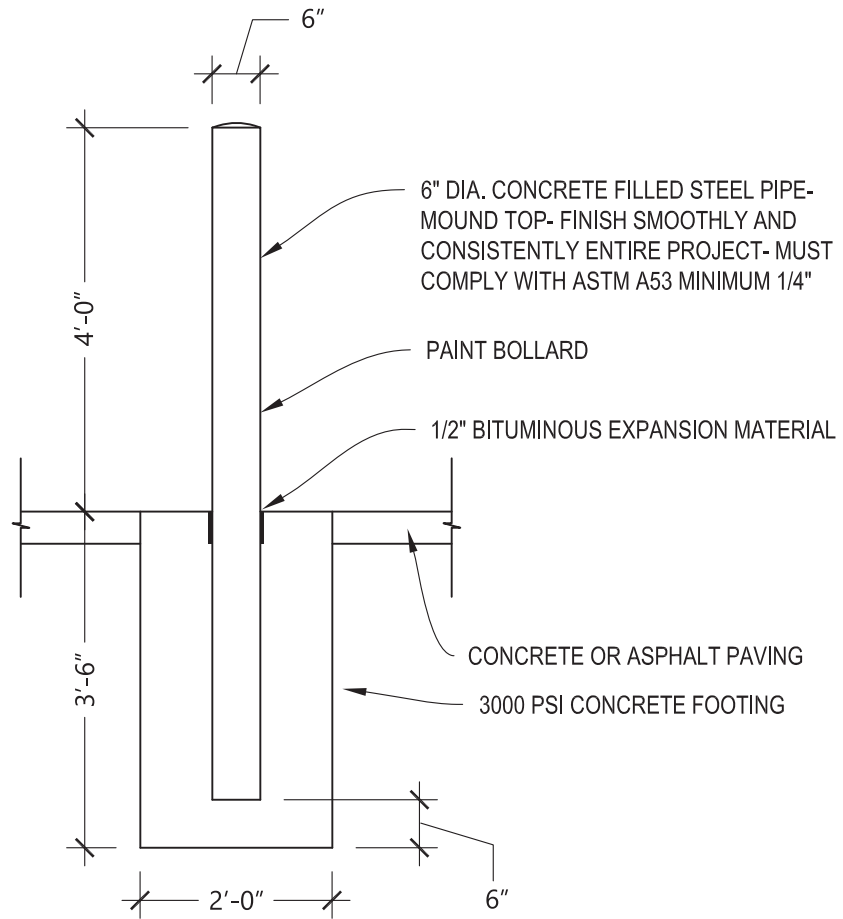

MASS FOOTING SECTION

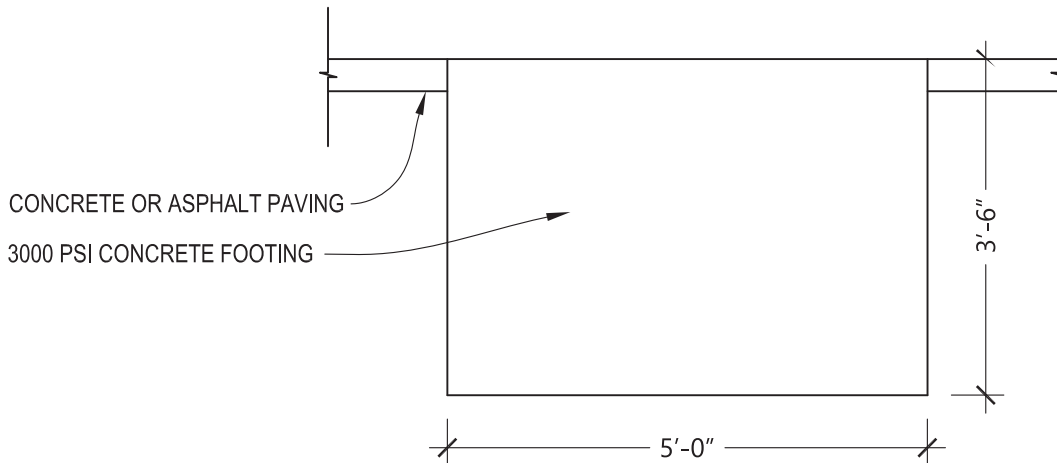

(FOR OFFICE USE ONLY)

CARTO 28 C

B					
A					
DESCRIPTION		DRWN	CHKD	APPD	DATE
REVISIONS					
DRAWN BY	<i>KJ</i>	CHECKED	<i>KSM</i>		
DATE	<i>07-20-20</i>	APPROVED BY	<i>JD</i>		

*MULTIPLE ENCROACHMENTS AT 1331
MICHIGAN AVE., IN THE BLOCK
BOUND BY MICHIGAN AVE., LEVERETTE
AVE., AND 8TH STREET.*

CITY OF DETROIT
CITY ENGINEERING DIVISION
SURVEY BUREAU

JOB NO. *01-03*

DRWG. NO. *X*

City of Detroit
City Engineering Division, Department of Public Works
Maps and Records Bureau

NOTICE OF PROPOSED CHANGE IN PROPERTY

Date: _____

Petition: _____

- | | |
|---|---|
| <input type="checkbox"/> AT&T Telecommunication | |
| <input type="checkbox"/> Comcast Television (CATV) | <input type="checkbox"/> Berm Use |
| <input type="checkbox"/> Detroit Edison (DTE) | |
| <input type="checkbox"/> Fire Department | <input type="checkbox"/> Conversion to Easement |
| <input type="checkbox"/> Great Lakes Water Authority | |
| <input type="checkbox"/> Land Bank Authority | <input type="checkbox"/> Dedication |
| <input type="checkbox"/> Michcon (DTE) | |
| <input type="checkbox"/> Planning & Development Department | <input type="checkbox"/> Encroachment |
| <input type="checkbox"/> Public Lighting Authority | |
| <input type="checkbox"/> Public Lighting Department | <input type="checkbox"/> Outright Vacation |
| <input type="checkbox"/> Police Department | |
| <input type="checkbox"/> Solid Waste Division, DPW | <input type="checkbox"/> Temporary Closing |
| <input type="checkbox"/> Street Design Bureau, DPW | |
| <input type="checkbox"/> Street Maintenance Division, DPW | |
| <input type="checkbox"/> Traffic Engineering Division, DPW | |
| <input type="checkbox"/> Water and Sewerage Department | |
| <input type="checkbox"/> Detroit Thermal | |
| <input type="checkbox"/> International Transmission Company (ITC) | |

A petition drawing is attached. Property shown on the attached print is proposed to be changed as indicated. Kindly report (using the back of this sheet) the nature of your services, if any affected by the proposed change and the estimated costs of removing and rerouting such services (if necessary). If a response is not received after a second notice of proposed change has been issued DPW will make the determination to move forward with the petition.

Please return one copy to City Engineering Division, DPW within two weeks of the submittal date. Retain one copy and print for you file.

Ron Brundidge, Director, Department of Public Works

By: Richard Doherty, CED DPW
City Engineer

**TO: City Engineering Division, DPW
2 Woodward Ave., Suite 642
Detroit, Michigan 48226-3462
Survey Bureau: 313-224-3970**

Petition: _____

The proposed change in property (referred to on the other side of this sheet) would affect our services as follows:

- Not Involved
- Involved; but no objections to the property change.
- Involved; objection to the property change.
- Involved; the nature of our services and the estimated costs of removing and/or rerouting such services are:

Objections, Please leave a brief explanation for any objection or the nature of an estimated cost:

(Utility or City Department)

By

Title

Date

Area code – Telephone number

City of Detroit

Janice M. Winfrey
City Clerk

OFFICE OF THE CITY CLERK

Andre P. Gilbert II
Deputy City Clerk

DEPARTMENTAL REFERENCE COMMUNICATION

Monday, August 24, 2020

To: The Department or Commission Listed Below

From: Janice M. Winfrey, Detroit City Clerk

The following petition is herewith referred to you for report and recommendation to the City Council.

In accordance with that body's directive, kindly return the same with your report in duplicate within four (4) weeks.

DPW - CITY ENGINEERING DIVISION PLANNING AND DEVELOPMENT DEPARTMENT

1318 *Parkstone Development Partners, request to encroach into 8th St. between Michigan Ave and Leverette St for the purpose of installing Mass Footings, and encroach into Leverette betw 8th and Michigan w fencing, mass footings and bollards*



CITY OF DETROIT
DEPARTMENT OF PUBLIC WORKS
CITY ENGINEERING DIVISION

1315
COLEMAN A. YOUNG MUNICIPAL CENTER
2 WOODWARD AVE. SUITE 601
DETROIT, MICHIGAN 48226
PHONE: (313) 224-3949 • TTY: 711
FAX: (313) 224-3471
WWW.DETROITMI.GOV

To: Clerk's Office
From: The Department of Public Works
City Engineering Division
MapsandRecordsBureau@DetroitMI.Gov
(313) 224-3970

Petitioner:
Parkstone Development Partners
On behalf of CH Corktown, LLC
28 W Adams Avenue, Suite 1300
Detroit, MI 48226
(313) 636-1518

On behalf of the above mentioned petitioner the Department of Public Works: City Engineering Division is submitting a petition request for the below mentioned action. The petitioner has received a project consultation from the Department of Public Works: City Engineering Division and has been advised the following:

Type of action recommended:

Petition to encroach into 8th Street between Michigan Avenue and Leverette Street for the purpose of installing Mass Footings. And encroach into Leverette Street between 8th Street and Michigan Avenue with fencing, Mass Footings, and bollards.

Based on the scope of the project the following requirements have been outlined:

- No further requirements noted.

Sincerely,

Jered Dean
Manager II
Maps and Records Bureau



PARKSTONE
Development Partners

August 5, 2020

Honorable Detroit City Council
C/o Detroit City Clerk
2 Woodward Avenue
200 Coleman A. Young Municipal Center
Detroit, MI 48226

RE: CH Corktown, LLC – Request for encroachment into Leverette and 8th Streets

Dear Honorable Council Members,

On behalf of CH Corktown, LLC, Parkstone Development Partners would like to request an encroachment into the Leverette and Eighth Street rights-of-way at 1375 Michigan within the block bounded by Michigan, Leverette, and Eighth. The purpose of the encroachment is to allow for concrete mass footings at two new exterior wall openings on 8th and Leverette, approval of an existing fence encroachment along Leverette, and new bollards within the encroachment along Leverette.

Please feel free to contact me with any questions at janelle@parkstonedevelopment.com or at 313-636-1518. Thank you for your time and attention toward this matter.

Respectfully,

Janelle Bulat, Project Manager
Parkstone Development Partners

2020-08-24

1318

1318 *Petition of Parkstone Development Partners, request to encroach into 8th St. between Michigan Ave and Leverette St for the purpose of installing Mass Footings, and encroach into Leverette betw 8th and Michigan w fencing, mass footings and bollards*

REFERRED TO THE FOLLOWING DEPARTMENT(S)

DPW - CITY ENGINEERING DIVISION PLANNING AND DEVELOPMENT DEPARTMENT