

GLWA GPET 30-301 (x1287)

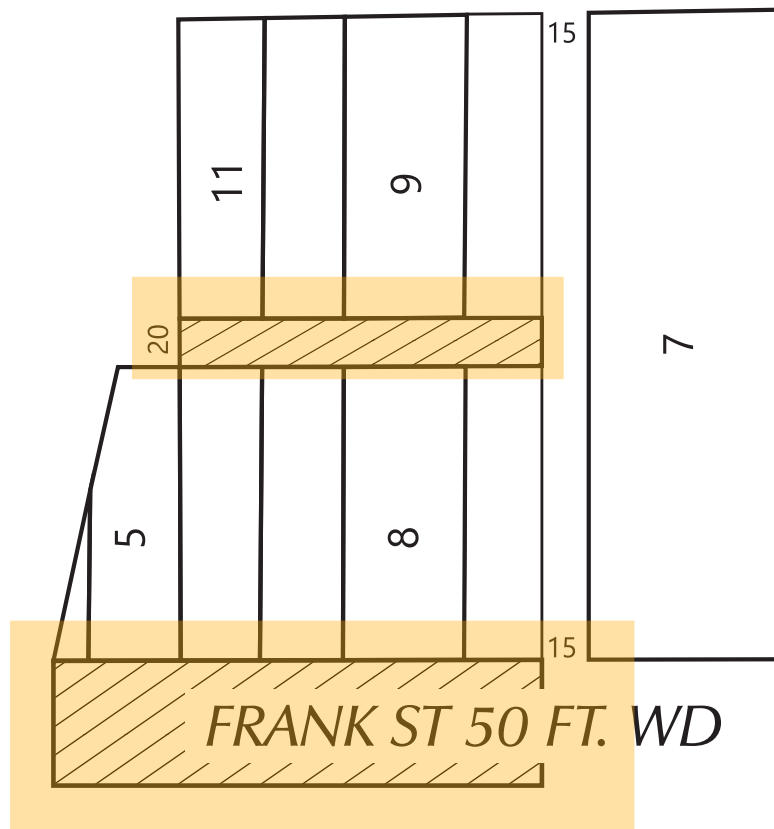

WEST ALEXANDRINE AVE 50 FT. WD

JOHN C LODGE EXPRESSWAY



FOURTH AVE 50 FT. WD



- CONVERSION TO EASEMENT

(FOR OFFICE USE ONLY)

CARTO 29 C

B					
A					
DESCRIPTION	DRWN	CHKD	APPD	DATE	
REVISIONS					
DRAWN BY	KJ		CHECKED	KSM	
DATE	06-01-20		APPROVED BY	JD	

CONVERSION TO EASEMENT OF
THE EAST/WEST PUBLIC ALLEY AND PART OF
FRANK ST. IN THE BLOCK BOUND BY FRANK
ST., THE JOHN C LODGE EXPRESSWAY,
ALEXANDRINE AVE., AND FOURTH ST.

CITY OF DETROIT
CITY ENGINEERING DIVISION
SURVEY BUREAU

JOB NO. 01-01
DRWG. NO. X

City of Detroit
City Engineering Division, Department of Public Works
Maps and Records Bureau

NOTICE OF PROPOSED CHANGE IN PROPERTY

Date: _____

Petition: _____

- | | |
|---|---|
| <input type="checkbox"/> AT&T Telecommunication | |
| <input type="checkbox"/> Comcast Television (CATV) | <input type="checkbox"/> Berm Use |
| <input type="checkbox"/> Detroit Edison (DTE) | |
| <input type="checkbox"/> Fire Department | <input type="checkbox"/> Conversion to Easement |
| <input type="checkbox"/> Great Lakes Water Authority | |
| <input type="checkbox"/> Land Bank Authority | <input type="checkbox"/> Dedication |
| <input type="checkbox"/> Michcon (DTE) | |
| <input type="checkbox"/> Planning & Development Department | <input type="checkbox"/> Encroachment |
| <input type="checkbox"/> Public Lighting Authority | |
| <input type="checkbox"/> Public Lighting Department | <input type="checkbox"/> Outright Vacation |
| <input type="checkbox"/> Police Department | |
| <input type="checkbox"/> Solid Waste Division, DPW | <input type="checkbox"/> Temporary Closing |
| <input type="checkbox"/> Street Design Bureau, DPW | |
| <input type="checkbox"/> Street Maintenance Division, DPW | |
| <input type="checkbox"/> Traffic Engineering Division, DPW | |
| <input type="checkbox"/> Water and Sewerage Department | |
| <input type="checkbox"/> Detroit Thermal | |
| <input type="checkbox"/> International Transmission Company (ITC) | |

A petition drawing is attached. Property shown on the attached print is proposed to be changed as indicated. Kindly report (using the back of this sheet) the nature of your services, if any affected by the proposed change and the estimated costs of removing and rerouting such services (if necessary). If a response is not received after a second notice of proposed change has been issued DPW will make the determination to move forward with the petition.

Please return one copy to City Engineering Division, DPW within two weeks of the submittal date. Retain one copy and print for you file.

Ron Brundidge, Director, Department of Public Works

By: Richard Doherty, CED DPW
City Engineer

**TO: City Engineering Division, DPW
2 Woodward Ave., Suite 642
Detroit, Michigan 48226-3462
Survey Bureau: 313-224-3970**

Petition: _____

The proposed change in property (referred to on the other side of this sheet) would affect our services as follows:

- Not Involved
- Involved; but no objections to the property change.
- Involved; objection to the property change.
- Involved; the nature of our services and the estimated costs of removing and/or rerouting such services are:

Objections, Please leave a brief explanation for any objection or the nature of an estimated cost:

(Utility or City Department)

By

Title

Date

Area code – Telephone number

Janice M. Winfrey
City Clerk

City of Detroit
OFFICE OF THE CITY CLERK

Andre P. Gilbert II
Deputy City Clerk

DEPARTMENTAL REFERENCE COMMUNICATION

Thursday, June 18, 2020

To: The Department or Commission Listed Below

From: Janice M. Winfrey, Detroit City Clerk

The following petition is herewith referred to you for report and recommendation to the City Council.

In accordance with that body's directive, kindly return the same with your report in duplicate within four (4) weeks.

PLANNING AND DEVELOPMENT DEPARTMENT
DPW - CITY ENGINEERING DIVISION

1287 *Selden Innovation Center, LLC request to vacate and convert to easement a portion of Frank Street east of the Lodge FWY and the east-west alley east of the Lodge FWY, bounded by W. Alexandrine and Frank St.*



CITY OF DETROIT
DEPARTMENT OF PUBLIC WORKS
CITY ENGINEERING DIVISION

COLEMAN A. YOUNG MUNICIPAL CENTER
2 WOODWARD AVE. SUITE 601
DETROIT, MICHIGAN 48226
PHONE: (313) 224-3949 • TTY:711
FAX: (313) 224-3471
WWW.DETROITMI.GOV

To: Clerk's Office
From: The Department of Public Works
City Engineering Division
MapsandRecordsBureau@DetroitMI.Gov
(313) 224-3970

Petitioner:
Selden Innovation Center, LLC
Represented by Parkstone Development Partners
28 West Adams Avenue, Suite 1300, Detroit, MI 48226
313-636-1518

On behalf of the above mentioned petitioner the Department of Public Works: City Engineering Division is submitting a petition request for the below mentioned action. The petitioner has received a project consultation from the Department of Public Works: City Engineering Division and has been advised the following:

Type of action recommended:

Petition to vacate and convert to easement a portion of Frank Street east of the John C. Lodge Freeway and the east-west alley east of the John C. Lodge Freeway, bounded by West Alexandrine Avenue and Frank Street.

Based on the scope of the project the following requirements have been outlined:

- No further requirements noted.

Sincerely,

Jered Dean
Manager II
Maps and Records Bureau



PARKSTONE
DEVELOPMENT PARTNERS

June 4, 2020

The Honorable City Council
ATTN: Office of the City Clerk
200 Coleman A. Young Municipal Center
Detroit, MI 48226

Dear Council Members:

On behalf of Selden Innovation Center, LLC, we would like to petition the City of Detroit for the conversion to easement of that portion of Frank Street located between the John C Lodge Service Drive and the western edge of the alley first west of 4th Street, as well as the East-West alley located between the John C Lodge Service Drive, Alexandrine Street, 4th Street, and Frank Street.

Both the street closure and the alley closure are part of a larger redevelopment plan for the former Jefferson School building. The purpose of the closure of Frank Street is to allow for a pedestrian connection between the existing building and the proposed parking lot, and the purpose of the alley closure is to allow for consolidation of the proposed parking lot. Please find attached a preliminary site plan that depicts these development plans.

Thank you for your attention toward this matter. Please feel free to contact Parkstone Development Partners with any questions or concerns related to this request.

Respectfully,

Janelle Bulat
Project Manager, Parkstone Development Partners
313-636-1518
janelle@parkstonedevelopment.com

Sue Mosey,
President, Selden Innovation Center LLC
smosey@midtowndetroitinc.org

2020-06-18

1287

1287 *Selden Innovation Center, LLC request to vacate and convert to easement a portion of Frank Street east of the Lodge FWY and the east-west alley east of the Lodge FWY...*

REFERRED TO THE FOLLOWING DEPARTMENT(S)

PLANNING AND DEVELOPMENT DEPARTMENT
DPW - CITY ENGINEERING DIVISION