

Petition No. 1287  
 Selden Innovation Center, LLC  
 Represented by Parkstone Development Partners  
 28 West Adams Avenue, Suite 1300, Detroit, MI 48226  
 (313) 636-1518  
 C/O Janelle Bulat

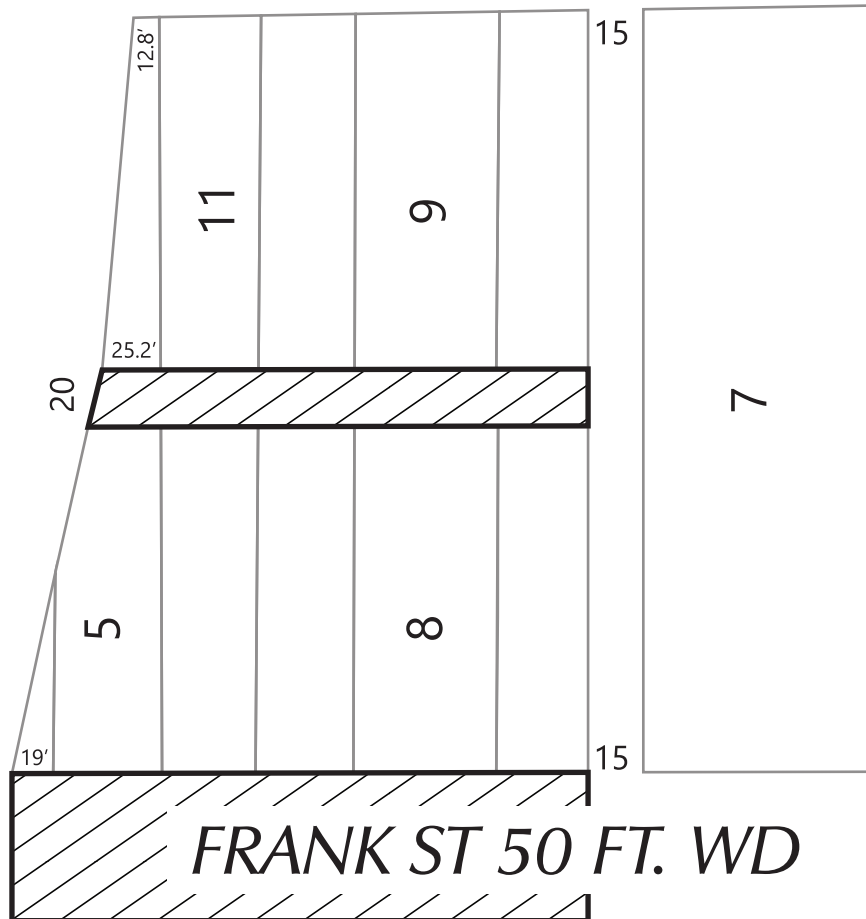

**WEST ALEXANDRINE AVE 50 FT. WD**

**JOHN C LODGE EXPRESSWAY**



**FOURTH AVE 50 FT. WD**



- CONVERSION TO EASEMENT

(FOR OFFICE USE ONLY)

CARTO 29 C

<b>B</b>					
<b>A</b>					
DESCRIPTION		DRWN	CHKD	APPD	DATE
REVISIONS					
DRAWN BY	KJ		CHECKED	KSM	
DATE	06-01-20		APPROVED BY	JD	

CONVERSION TO EASEMENT OF  
 THE EAST/WEST PUBLIC ALLEY AND PART OF  
 FRANK ST. IN THE BLOCK BOUND BY FRANK  
 ST., THE JOHN C LODGE EXPRESSWAY,  
 ALEXANDRINE AVE., AND FOURTH ST.

**CITY OF DETROIT**  
 CITY ENGINEERING DIVISION  
 SURVEY BUREAU

JOB NO. 01-01  
 DRWG. NO. X 1287