



CITY OF DETROIT
DEPARTMENT OF PUBLIC WORKS
CITY ENGINEERING DIVISION

COLEMAN A. YOUNG MUNICIPAL CENTER
2 WOODWARD AVE. SUITE 601
DETROIT, MICHIGAN 48226
PHONE: (313) 224-3949 • TTY: 711
FAX: (313) 224-3471
WWW.DETROITMI.GOV

April 22nd, 2020

Honorable City Council:

RE: Petition No. 1243 by Firm Real Estate Management I, LLC, on behalf of 2456 Market LLC, request for encroachment into the right-of-way at 2459 Riopelle Street, bounded by Winder Street and Napoleon Street.

Petition No. 1243 by Firm Real Estate Management 1, LLC request for encroachment below grade for an existing basement area associated with the building located at 2459 Riopelle Street. The encroachment is on the west side of Riopelle Street, 39 feet wide, between Winder Street, 50 feet wide, and Napoleon Street.

The petition was referred to the City Engineering Division – DPW for investigation and report. This is our report.

The request is being made to renew the pre-existing below grade encroachment located at 2459 Riopelle Street.

The request was approved by the Solid Waste Division – DPW, and City Engineering Division – DPW. The request was approved by DPW – Traffic Engineering Division (TED) provided certain conditions are met. The TED conditions are a part of the resolution.

Detroit Water and Sewerage Department (DWSD) reports involvement. The standard DWSD provisions for encroachments have been made a part of the resolution.

All other involved City Departments and privately owned utility companies have reported no objections to the encroachment. Provisions protecting all utility installations are part of the attached resolution.

I am recommending adoption of the attached resolution.

Respectfully submitted,

Richard Doherty, P.E., City Engineer
City Engineering Division – DPW

/JK

Cc: Ron Brundidge, Director, DPW
Mayor's Office – City Council Liaison

COUNCIL MEMBER _____

RESOLVED, request for encroachment below grade for an existing basement area associated with the building located at 2459 Riopelle Street. Location of the below grade encroachment is described as follows: land in the City of Detroit, Wayne County, Michigan being the westerly 4.2 feet of Riopelle Street, 39 feet wide, adjoining the east property line ranging from 8" north from the south property line to 8" south of the north property line of Lot I of "Subdivision of part of the Riopelle Farm" as recorded in Liber 1, Pages 135 of Plats, Wayne County Records. The encroachments further described as follows: Basement area associated with the building located at 2459 Riopelle (2456 Market Street) existing 8.5 feet below grade.

The petition was referred to the City Engineering Division – DPW for investigation and report. This is our report.

The request is being made in order to have a public record of the existing underground vaults or areaways.

The request was approved by the Solid Waste Division – DPW, and City Engineering Division – DPW.

Detroit Water and Sewerage Department (DWSD) has no objection to the petition. The standard DWSD provisions for encroachments have been made a part of the resolution.

All other involved City Departments and privately owned utility companies have reported no objections to the encroachment. Provisions protecting all utility installations are part of the attached resolution.

PROVIDED, that the encroachment permits shall not be assigned or transferred without the written approval of the City Council. This encroachment being assigned to 2456 Market, LLC. In the event that ownership of the property known as 2459 Riopelle (2456 Market) is transferred this encroachment will become invalid; and be it further

PROVIDED, that the City Clerk shall within 30 days record a certified copy of this resolution with the Wayne County Register of Deeds.

I am recommending adoption of the attached resolution.

PETITION NO. 1243
 FIRM REAL ESTATE MANAGEMENT I, LLC.
 2459 RIOPELLE ST.
 DETROIT, MI 48207
 (C/O) CHARLES E. BRODEUR
 PHONE NO. (248) 416-4020



MARKET ST. 77 FT.WD.

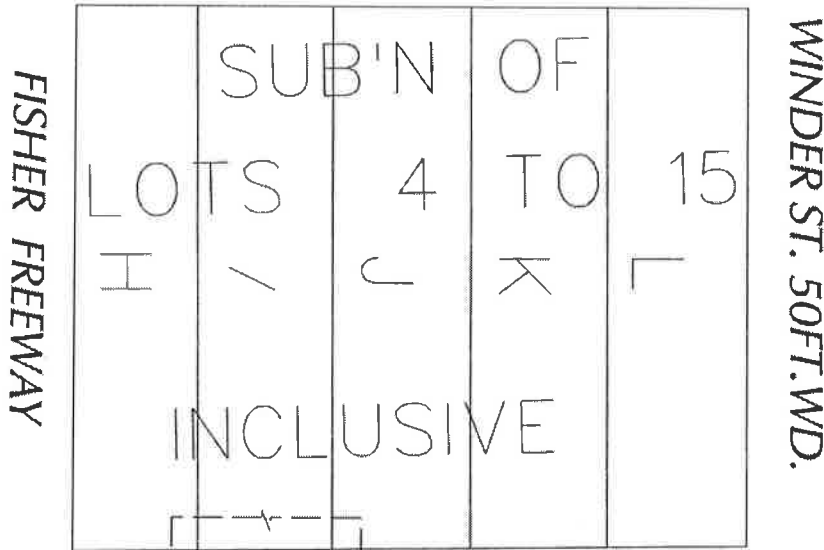

RIOPELLE ST. 39 FT.WD.

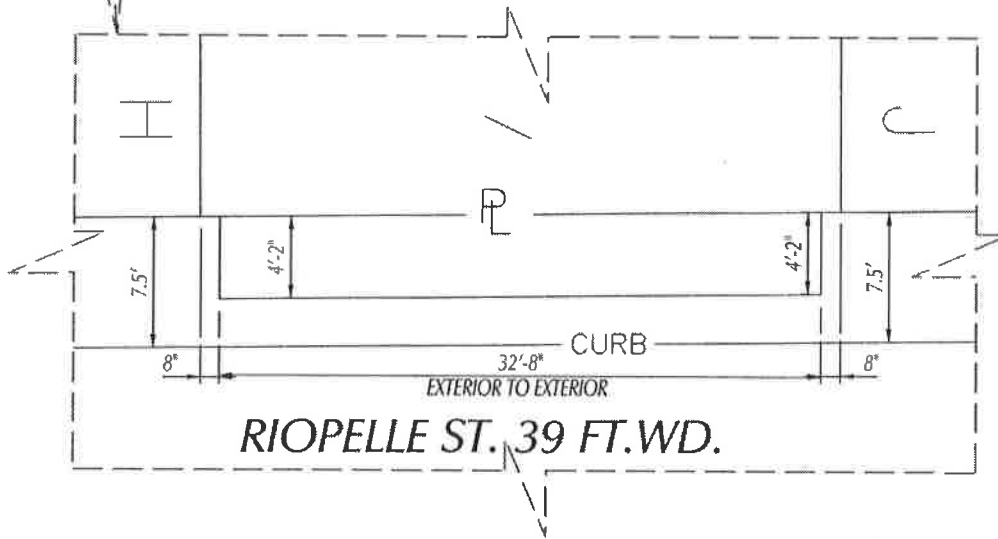

 - REQUEST ENCROACHMENT
 (FOR A PRE-EXISTING BELOW GRADE BASEMENT)

(FOR OFFICE USE ONLY)

CARTO 39 D

| B | | | | | |
|-------------|------|----------|------|------|----------|
| A | | | | | |
| DESCRIPTION | DRWN | CHKD | APPD | DATE | |
| REVISIONS | | | | | |
| DRAWN BY | SA | CHECKED | KSM | DATE | 03-17-20 |
| | | APPROVED | JD | | |

REQUEST ENCROACHMENT
 INTO RIOPELLE ST.
 AT 2459 RIOPELLE ST.
 (FOR A PRE-EXISTING BELOW GRADE
 BASEMENT)

| | |
|---|--------|
| CITY OF DETROIT CITY ENGINEERING DIVISION SURVEY BUREAU | |
| JOB NO. | 01-01 |
| DRWG. NO. | X 1243 |