



City of Detroit
Inter-Departmental Communication

TO: Richard Doherty, City Engineer
City Engineering/Department of Public Works

FROM: Debra Singleton, Engineer
Detroit Water and Sewerage Department

DATE: March 2, 2020

RE: Petition No. 1202
Request Outright Vacation Of The East/West Alley In The Block Bound By
Randolph, Gratiot, Brush, And Macomb

The Detroit Water and Sewerage Department (DWSD) is in receipt of the subject petition. There are a sewer and water main located in the requested outright vacation area. DWSD objects to the requested vacation unless the following conditions are met:

- The sewer and water main services no other properties and only services the properties owned by the Petitioner, if not the Petitioner must prepare relocation plans for the sewer and water main signed by a Registered Engineer, DWSD approves the relocation plans, and the Petitioner grants satisfactory easements for the relocated sewer and water main. The Petitioner is to bear the entire cost of the proposed relocation plans, including construction, demolition, permitting, inspection, survey, etc.
- If DWSD is to maintain ownership of any existing sewer or water main a satisfactory easement must be granted by the Petitioner.

The entire work is to be performed in accordance with DWSD specifications and standards, all of the fees are to be deposited with DWSD in advance, to cover the necessary costs of permits and inspection.

Contact the DWSD Permits Section directly to discuss this petition. If you have any questions, please feel free to call me at (313) 267-8309 or Mohammed Fa Siddique at (313) 964-9245.

Sincerely,

Debra Singleton
Engineer Permits Section

DS/MS/gl
Attachments
CC::Mohamad Farhart, CSF

City of Detroit
City Engineering Division, Department of Public Works
Maps and Records Bureau

NOTICE OF PROPOSED CHANGE IN PROPERTY

Date: _____

Petition: _____

- | | |
|---|---|
| <input type="checkbox"/> AT&T Telecommunication | |
| <input type="checkbox"/> Comcast Television (CATV) | <input type="checkbox"/> Berm Use |
| <input type="checkbox"/> Detroit Edison (DTE) | |
| <input type="checkbox"/> Fire Department | <input type="checkbox"/> Conversion to Easement |
| <input type="checkbox"/> Great Lakes Water Authority | |
| <input type="checkbox"/> Land Bank Authority | <input type="checkbox"/> Dedication |
| <input type="checkbox"/> Michcon (DTE) | |
| <input type="checkbox"/> Planning & Development Department | <input type="checkbox"/> Encroachment |
| <input type="checkbox"/> Public Lighting Authority | |
| <input type="checkbox"/> Public Lighting Department | <input type="checkbox"/> Outright Vacation |
| <input type="checkbox"/> Police Department | |
| <input type="checkbox"/> Solid Waste Division, DPW | <input type="checkbox"/> Temporary Closing |
| <input type="checkbox"/> Street Design Bureau, DPW | |
| <input type="checkbox"/> Street Maintenance Division, DPW | |
| <input type="checkbox"/> Traffic Engineering Division, DPW | |
| <input type="checkbox"/> Water and Sewerage Department | |
| <input type="checkbox"/> Detroit Thermal | |
| <input type="checkbox"/> International Transmission Company (ITC) | |

A petition drawing is attached. Property shown on the attached print is proposed to be changed as indicated. Kindly report (using the back of this sheet) the nature of your services, if any affected by the proposed change and the estimated costs of removing and rerouting such services (if necessary). If a response is not received after a second notice of proposed change has been issued DPW will make the determination to move forward with the petition.

Please return one copy to City Engineering Division, DPW within two weeks of the submittal date. Retain one copy and print for you file.

Ron Brundidge, Director, Department of Public Works

By: Richard Doherty, CED DPW
City Engineer

**TO: City Engineering Division, DPW
2 Woodward Ave., Suite 642
Detroit, Michigan 48226-3462
Survey Bureau: 313-224-3970**

Petition: _____

The proposed change in property (referred to on the other side of this sheet) would affect our services as follows:

- Not Involved
- Involved; but no objections to the property change.
- Involved; objection to the property change.
- Involved; the nature of our services and the estimated costs of removing and/or rerouting such services are:

Objections, Please leave a brief explanation for any objection or the nature of an estimated cost:

(Utility or City Department)

By

Title

Date

Area code – Telephone number

PETITION NO. 1202
 GRATIOT ACQUISITION PARTNERS, LLC
 30301 NORTHWESTERN HWY, SUIT 200
 FARMINGTON HILLS, MI 48334
 C/O EMIL S. BUNEK (PEA INC.)
 PHONE NO. (313) 769-5757

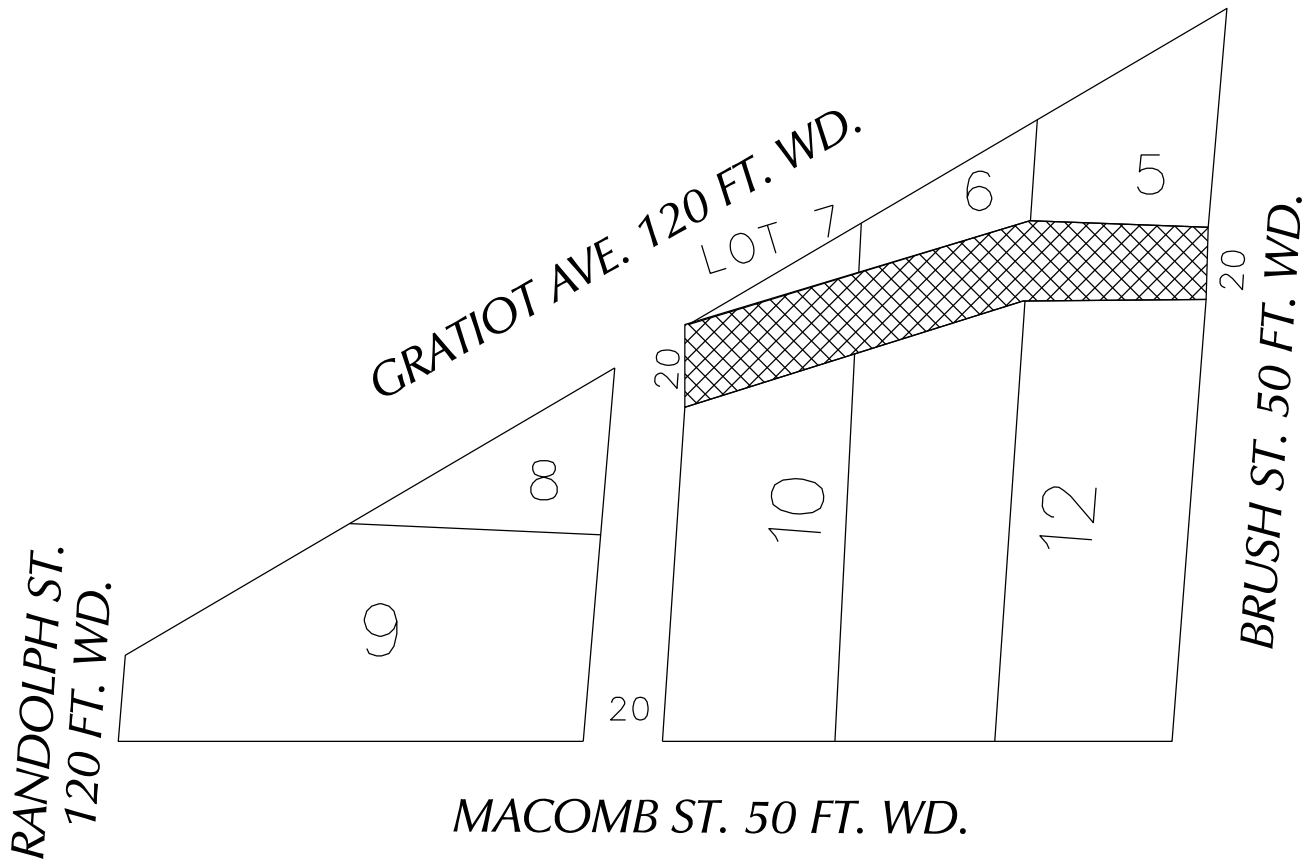

- OUTRIGHT VACATION

(FOR OFFICE USE ONLY)

CARTO 28 A

B					
A					
DESCRIPTION		DRWN	CHKD	APPD	DATE
REVISIONS					
DRAWN BY	SA	CHECKED		KSM	
DATE	02-19-20	APPROVED			

REQUEST TO OUTRIGHT VACATE
 THE EAST/WEST PUBLIC ALLEY, 20 FT. WD.
 IN THE BLOCK BOUND BY
 RANDOLPH ST., GRATIOT AVE.,
 BRUSH ST. AND MACOMB ST.

CITY OF DETROIT
 CITY ENGINEERING DIVISION
 SURVEY BUREAU

JOB NO. 01-01

DRWG. NO. X 1202

**Detroit Water & Sewerage Department
Provisions for Relocation Due to Vacation for Petition No. 1202**

Provided that the petitioner shall design and construct proposed sewers and or water mains plus make the connections to the existing public sewers and or water mains as required by the Detroit Water and Sewerage Department (DWSD) prior to construction of the proposed sewers and or water mains,

Provided that the plans for the sewers and or water mains shall be prepared by a registered engineer; and further

Provided that DWSD be and is hereby authorized to review the drawings for the proposed sewers and or water mains and to issue permits for the construction of the sewers and or water mains, and further

Provided that the entire work is to be performed in accordance with plans and specifications approved by DWSD and constructed under the inspection and approval of DWSD; and further

Provided that the entire cost of the proposed sewers and or water mains construction, including inspection, survey and engineering shall be borne by the petitioner; and further

Provided that the petitioner shall deposit with DWSD, in advance of engineering, inspection and survey, such amounts as the department deems necessary to cover the costs of these services; and further

Provided that the petitioner shall grant to the City a satisfactory easement for the sewers and or water mains; and further

Provided that the Board of Water Commissioners shall accept and execute the easement grant on behalf of the City; and further

Provided, that the petitioner shall provide DWSD with as -built drawings on the proposed sewers and or water mains; and further

Provided that the petitioner shall provide a one (1) year warranty for the proposed sewers and or water mains; and further

Provided that upon satisfactory completion, the sewers and or water mains shall become City property and become part of the City system. And any existing sewers or water mains that were abandoned shall belong to the petitioner and will no longer be the responsibility of the City.

06/30/14

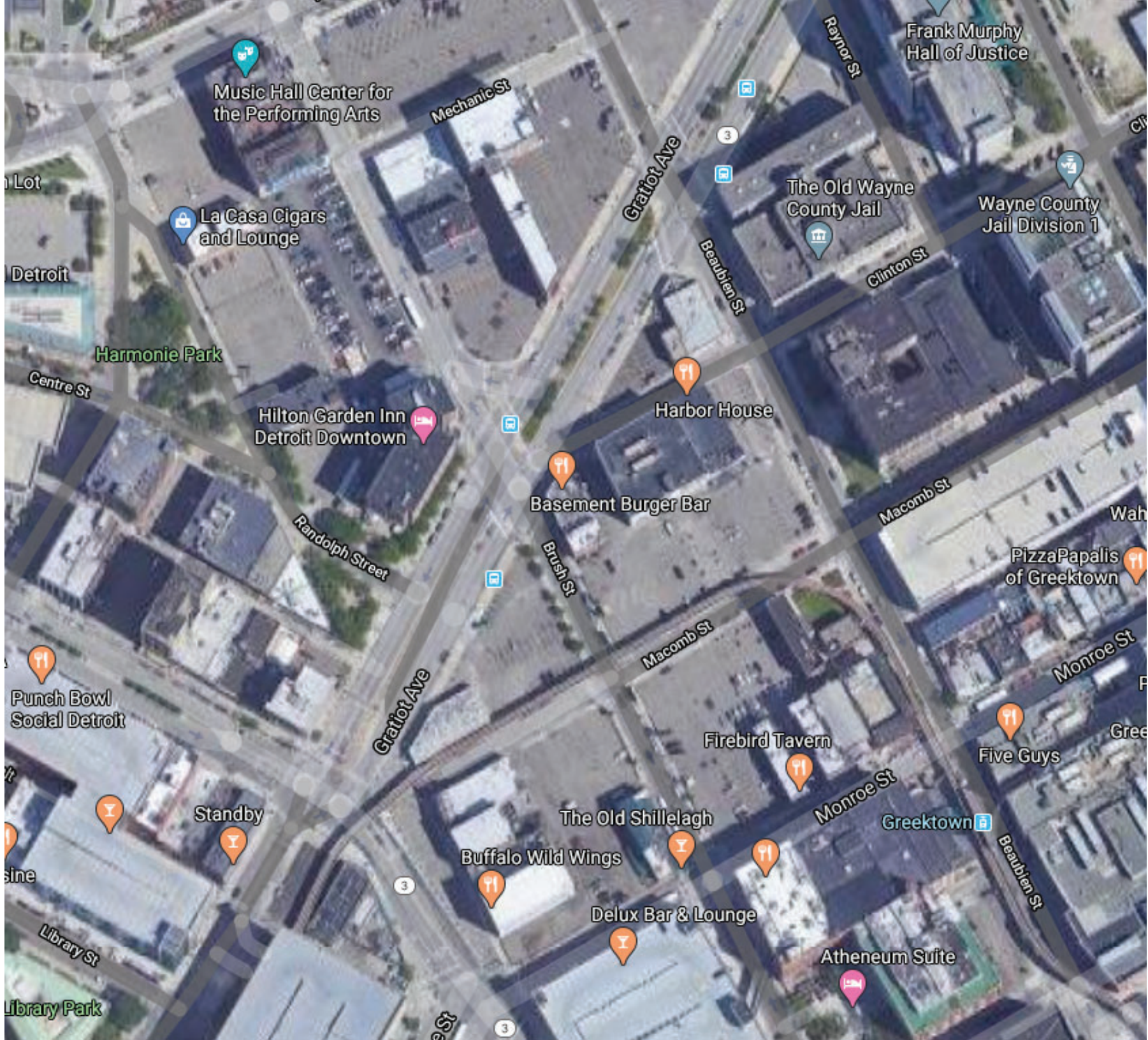

Music Hall Center for the Performing Arts

La Casa Cigars and Lounge

Harmonie Park

Hilton Garden Inn Detroit Downtown

Harbor House

Basement Burger Bar

Firebird Tavern

Five Guys

The Old Shillelagh

Buffalo Wild Wings

Delux Bar & Lounge

Athenium Suite

Frank Murphy Hall of Justice

The Old Wayne County Jail

Wayne County Jail Division 1

PizzaPapalis of Greektown

Greektown

Detroit

Punch Bowl Social Detroit

sine

Library Park

Wah

Gree

Monroe St

Beaubien St

Clinton St

Graftiot Ave

Beaubien St

Macomb St

Macomb St

Monroe St

Mechanic St

Randolph Street

Brush St

Graftiot Ave

Library St

Standby

Lot



See Page 22

2L 12'
10' Hub

6" 45° Curve

3L 12'

6" Gate & Wall

1-10" Spigot

6x4 Tee

7L 12'

Two 6" 45° Curves

3-6" Spigot

6x6 Tee + 1L 12' + Two 6" 45° Curves + 4L 12' +

6" Iron Plug

2" 90° Curve + 2' Spigot + 3x2 Hub + 4x3 Spigot + 4" 90° Curve
2' Spigot Reducer Reducer 4" Gate & Box
2" O.P. 1-3" Spigot

3-6" Spigot + 6x4 Tee

2L 12' + 6" 22 1/2° Curve + 2L 12' + 9' Hub + 6" Gate & Wall + 3' Hub + 6" 45° Curve

6' Hub + 6' Hub + 6" 45° Curve + 1-9' Hub + 6" Spigot + 3x6 Hub Reducer

Old 8x8 Tee

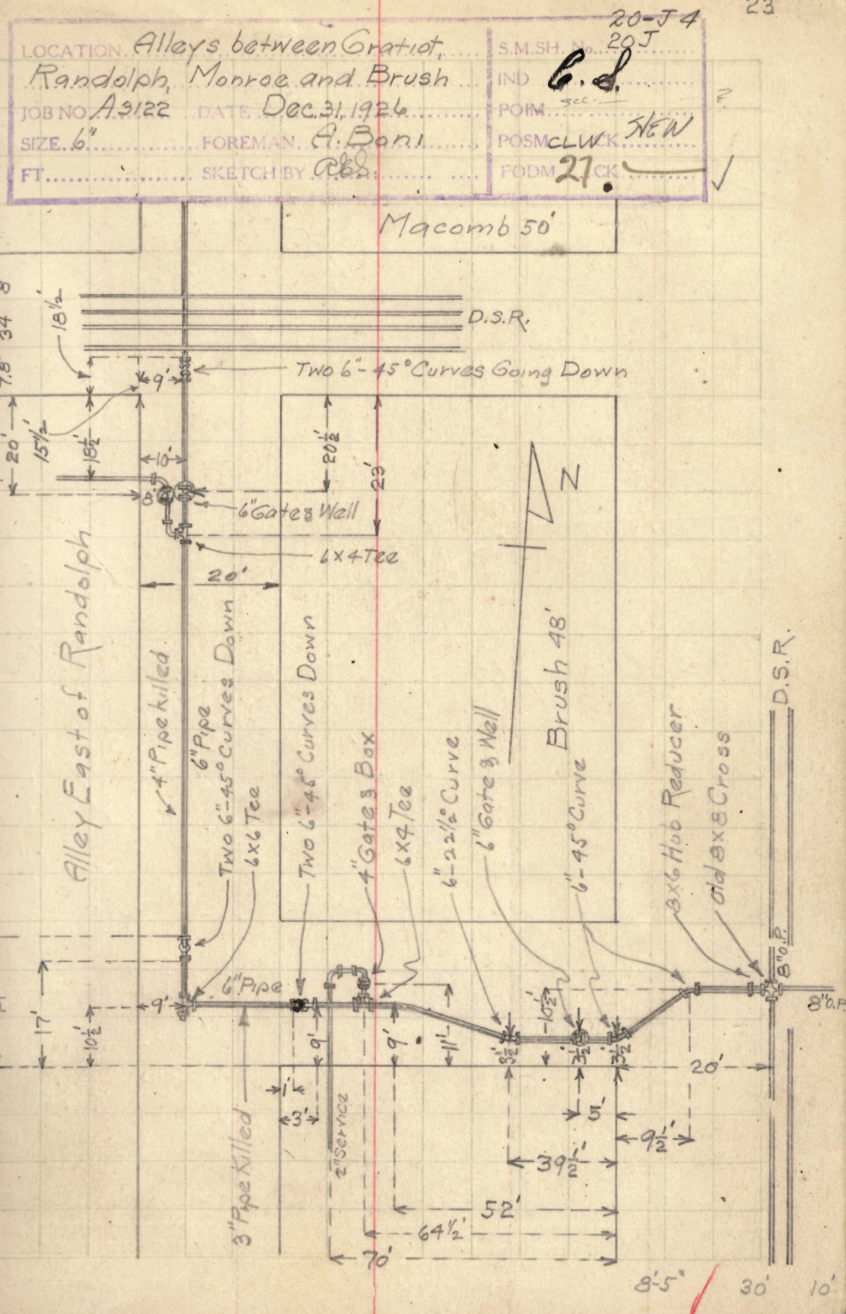

Profile of a lateral sewer in alley between
Maconic and Gratiot streets, in Block 9, Brush farm.

A.D. 1866.

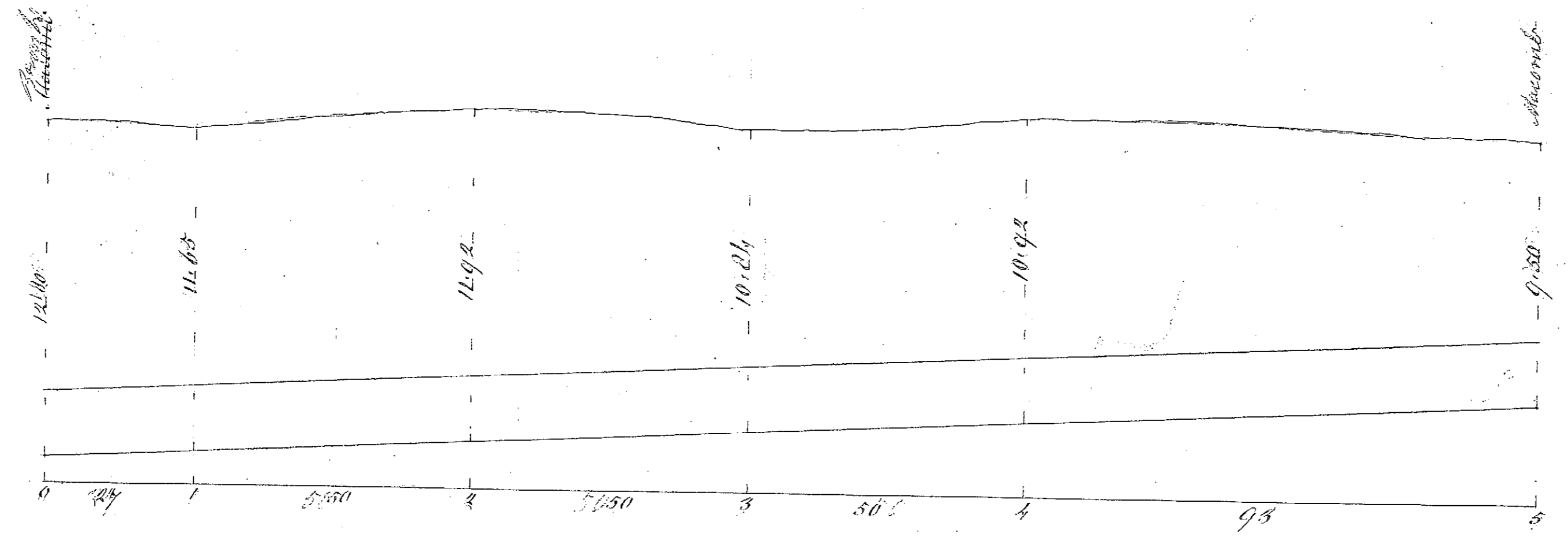

Ball & Co.

Scale 20 ft to an inch Horizontal.
4 " Vertical.
Grade 10" per 100 feet.

Length 240 feet.

91793

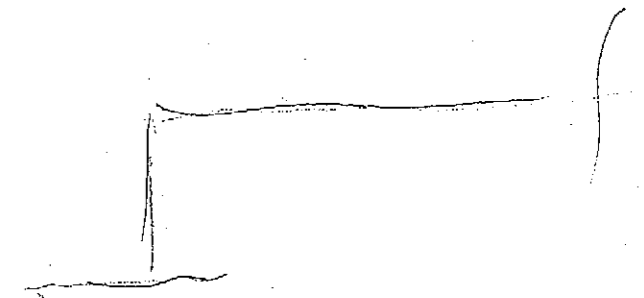

Janice M. Winfrey
City Clerk

City of Detroit
OFFICE OF THE CITY CLERK

Andre P. Gilbert II
Deputy City Clerk

DEPARTMENTAL REFERENCE COMMUNICATION

Tuesday, February 4, 2020

To: The Department or Commission Listed Below

From: Janice M. Winfrey, Detroit City Clerk

The following petition is herewith referred to you for report and recommendation to the City Council.

In accordance with that body's directive, kindly return the same with your report in duplicate within four (4) weeks.

DPW - CITY ENGINEERING DIVISION PLANNING AND DEVELOPMENT DEPARTMENT

1202 *Gratiot Acquisition Partners, LLC, request to vacate Public Utility Easement within 338 Gratiot Avenue, 343 Macomb Street, and 301 Macomb Street.*

2 Woodward Ave. Coleman A. Young Municipal Center Rm. 200, Detroit, MI 48226

(313) 224 - 3260 | Fax: (313) 224 - 1466



Civil Engineers | Land Surveyors | Landscape Architects

experienced. responsive. passion for quality.

Detroit Office: 45 West Grand River • Suite 501 • Detroit, MI 48226
t: 844.813.2949 • www.peainc.com

January 29, 2020
PEA Project No: 20-0027

Hand Delivered

Honorable Detroit City Council
C/o Detroit City Clerk
2 Woodward Avenue
200 Coleman A. Young Municipal Center
Detroit, Michigan 48226

RE: PEA – Request to Vacate Public Utility Easement within 338 Gratiot Avenue, 343 Macomb Street, and 301 Macomb Street.

Dear Honorable Detroit City Council:

PEA Inc. on behalf of Gratiot Acquisition Partners, LLC 30301 Northwestern Highway, Suite 200 Farmington Hills, MI 48334, Mark J. Bennett, Principal, respectfully requests the following outright vacation of the twenty-foot wide public utility easement located West of Brush Street and East of the alley South of Gratiot Avenue, and North of Macomb street. (Resolution 2202, Dated 3-13-08).

The requested vacation will neither impede pedestrian or vehicular traffic, nor will it interfere with the maintenance of the public rights-of-way, including utility company and Fire Department access. Required modifications to the existing public utilities will be made to continue existing service.

If you should have any questions or require any additional information, please feel free to contact me at 313-769-5757 or ebunek@peainc.com.

Sincerely,

PEA, Inc.

A handwritten signature in black ink, appearing to read 'Emil S. Bunek III'. The signature is written in a cursive, flowing style.

Emil S. Bunek III, PE
Project Coordinator

Attachment: Survey highlighting requested easement vacation.

Cc: Project Folder

2020-02-03

1202

1202 *Petition of Gratiot Acquisition
Partners, LLC, request to vacate
Public Utility Easement within 338
Gratiot Avenue, 343 Macomb Street,
and 301 Macomb Street.*

REFERRED TO THE FOLLOWING DEPARTMENT(S)

**DPW - CITY ENGINEERING DIVISION PLANNING AND
DEVELOPMENT DEPARTMENT**