

PETITION NO. 1202
 GRATIOT ACQUISITION PARTNERS, LLC
 30301 NORTHWESTERN HWY, SUIT 200
 FARMINGTON HILLS, MI 48334
 C/O EMIL S. BUNEK (PEA INC.)
 PHONE NO. (313) 769-5757

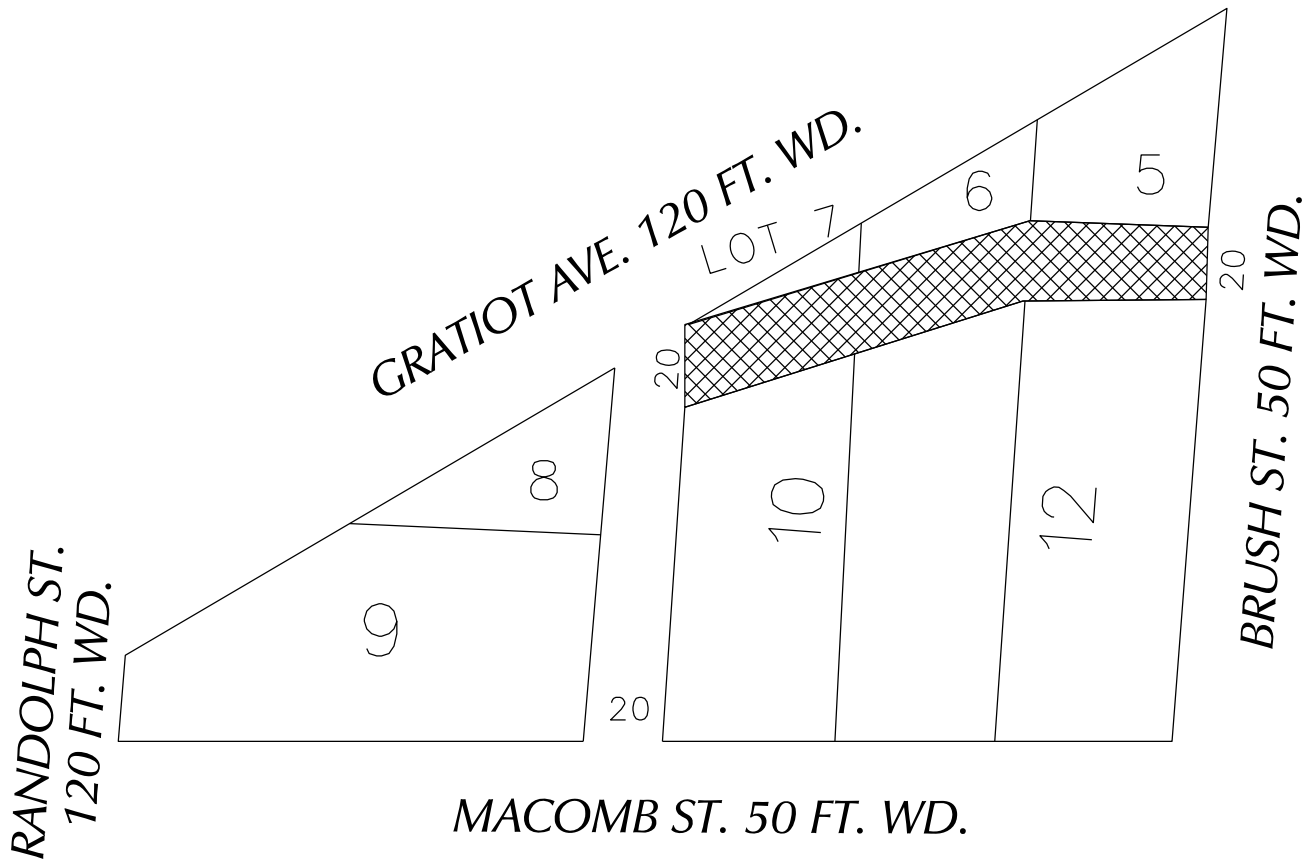

- OUTRIGHT VACATION

(FOR OFFICE USE ONLY)

CARTO 28 A

B					
A					
DESCRIPTION	DRWN	CHKD	APPD	DATE	
REVISIONS					
DRAWN BY	SA		CHECKED	KSM	
DATE	02-19-20		APPROVED		

REQUEST TO OUTRIGHT VACATE
 THE EAST/WEST PUBLIC ALLEY, 20 FT. WD.
 IN THE BLOCK BOUND BY
 RANDOLPH ST., GRATIOT AVE.,
 BRUSH ST. AND MACOMB ST.

CITY OF DETROIT
 CITY ENGINEERING DIVISION
 SURVEY BUREAU

JOB NO. 01-01

DRWG. NO. X 1202