



CITY OF DETROIT  
DEPARTMENT OF PUBLIC WORKS  
CITY ENGINEERING DIVISION

COLEMAN A. YOUNG MUNICIPAL CENTER  
2 WOODWARD AVE. SUITE 601  
DETROIT, MICHIGAN 48226  
PHONE: (313) 224-3949 • TTY: 711  
FAX: (313) 224-3471  
WWW.DETROITMI.GOV

November 18th, 2020

Petitioner,

RE: Petition No. 1148

Petition No. 1148 of "Heirloom Hospitality Group" request for encroachment into Second Avenue for façade features associated with 4128 Second Avenue.

The petition was referred to the City Engineering Division – DPW for investigation (utility review) and report. This is our report.

After reviewing the petitioner's request, it was determined the proposal did not detail all proposed encroachments planned for the façade at 4128 Second Avenue. Petition x1148 was submit on Nov 18<sup>th</sup>, 2019. The petitioner was informed that additional detail was required. At the current time the project has not moved forward and the City Engineering Division has received no status update. This petition has remained inactive for a period of 12 months.

The Department of Public Works, City Engineering Division **denies** this petition request. Please receive and file this report for your reference.

Respectfully submitted,

Richard Doherty, City Engineer  
City Engineering Division – DPW

JMK/

Cc: Ron Brundidge, Director – DPW  
Mayor's Office – City Council Liaison

PETITION NO. 1148  
 HEIRLOOM HOSPITALITY GROUP  
 C/O PARKSTON DEVELOPMENT PARTNERS  
 28 W ADAMS AVE. SUITE 1300  
 DETROIT, MICHIGAN 48226  
 JANELLE BULAT  
 PHONE NO. (313) 636-1518

**"REVISION-B-"**

CASS AVE. 80 FT. WD



WILLIS AVE. 100 FT. WD.

ALEXANDRINE AVE. 100 FT. WD.

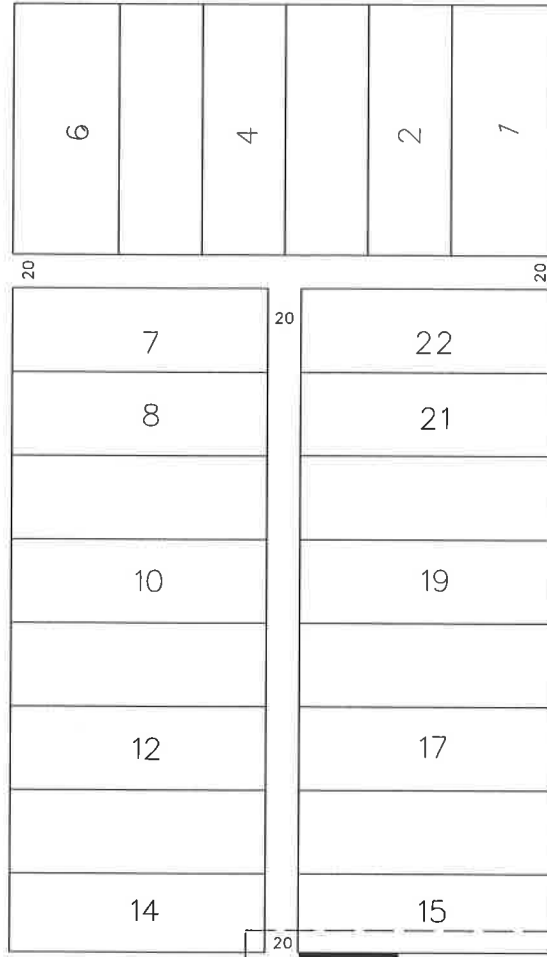

SECOND BLVD. 100 FT. WD.

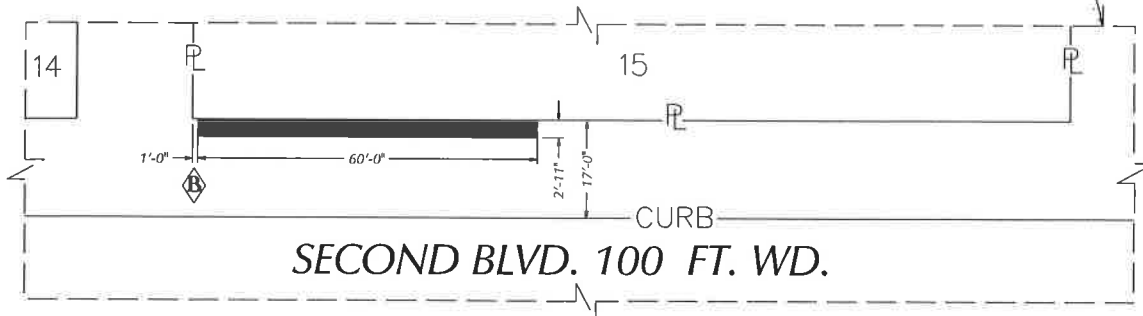

- REQUEST ENCROACHMENT

(FOR OFFICE USE ONLY)

CARTO 30 E

<b>B</b>	Revised: Correcting the distance between the north lot line of the property and the projecting sign	SA	KSM	JD	01/24/20
<b>A</b>	Revised: Revising the setback.	SA	KSM	JD	01/13/20
DESCRIPTION		DRWN	CHKD	APPD	DATE
REVISIONS					
DRAWN BY	SA	CHECKED		KSM	
DATE	12-11-19	APPROVED			

**REQUEST ENCROACHMENT  
 INTO SECOND AVE.  
 AT 4128 SECOND AVE.**

<b>CITY OF DETROIT</b>	
CITY ENGINEERING DIVISION	
SURVEY BUREAU	
JOB NO.	01-01
DRWG. NO.	X 1148