

City of Detroit
**City Engineering Division, Department of Public Works
Survey Bureau**

NOTICE OF PROPOSED CHANGE IN PROPERTY

Date: 07/03/2018

Petition: x371

- | | |
|--|--|
| <input type="checkbox"/> AT&T Telecommunication | <input type="checkbox"/> Berm Use |
| <input type="checkbox"/> Comcast Television (CATV) | <input type="checkbox"/> Conversion to Easement |
| <input type="checkbox"/> Detroit Edison (DTE) | <input type="checkbox"/> Dedication |
| <input type="checkbox"/> Fire Department | |
| <input type="checkbox"/> Great Lakes Water Authority | |
| <input type="checkbox"/> Land Bank Authority | |
| <input type="checkbox"/> Michcon (DTE) | |
| <hr/> | |
| <input type="checkbox"/> Planning & Development Department | <input checked="" type="checkbox"/> Encroachment |
| <input type="checkbox"/> Public Lighting Authority | |
| <input type="checkbox"/> Public Lighting Department | <input type="checkbox"/> Outright Vacation |
| <input type="checkbox"/> Police Department | |
| <input type="checkbox"/> Solid Waste Division, DPW | <input type="checkbox"/> Temporary Closing |
| <input type="checkbox"/> Street Design Bureau, DPW | |
| <input type="checkbox"/> Street Maintenance Division, DPW | |
| <input type="checkbox"/> Traffic Engineering Division, DPW | |
| <input type="checkbox"/> Water and Sewerage Department | |
| <input type="checkbox"/> _____ | |

A petition drawing is attached. Property shown on the attached print is proposed to be changed as indicated. Kindly report (using the back of this sheet) the nature of your services, if any affected by the proposed change and the estimated costs of removing and rerouting such services (if necessary).

Please return one copy to City Engineering Division, DPW within two weeks of the submittal date. Retain one copy and print for you file.

Ron Brundidge, Director, Department of Public Works

By: Richard Doherty, CED DPW
City Engineer

TO: City Engineering Division, DPW
2 Woodward Ave., Suite 642
Detroit, Michigan 48226-3462
Survey Bureau: 313-224-3970

Petition: x371

The proposed change in property (referred to on the other side of this sheet) would affect our services as follows:

- Not Involved
- Involved; but asking you to hold action on this petition until further notice.
- Involved; but no objections to the property change.

- Involved; objection to the property change.
- Involved; but no objections to the property change...provided as easement of the full width of the public right-of-way (street, alley or other public place) is reserved.
- Involved; the nature of our services and the estimated costs of removing and/or rerouting such services are:

DETROIT POLICE DEPARTMENT
(Utility or City Department)

N.P.O. STEVE ENGBRETSON
By

NEIGHBORHOODS POLICE OFFICER
Title

JULY 6, 2018
Date

(313) 237-2856
Area code – Telephone number

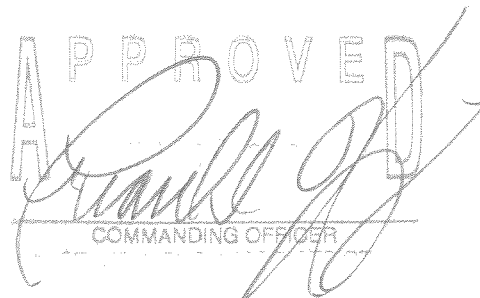
APPROVED

COMMANDING OFFICER



May 29, 2018

HAND DELIVER

Honorable Detroit City Council
C/o Detroit City Clerk
200 Coleman A. Young Municipal Center
2 Woodward Avenue
Detroit, Michigan 48226

RE: Giffels Webster - Request to encroach into a vacated Right of Way converted to public easement.

Giffels Webster, 28 W. Adams, Suite 1200, Detroit, Michigan 48226 on behalf of The Detroit Public Schools Community District, 1601 Farnsworth, Detroit, MI, 48211 respectfully requests the following encroachment into a City of Detroit vacated public right of way converted to easement:

- A flagpole and its concrete foundation encroaching into the vacated Henry Street right of way (100 feet wide) converted to public easement located just west of Second Avenue (100 feet wide). This encroachment extends 5.8 feet into the vacated Henry Street easement.

Limits of the requested easement can be found in the attachment, enclosed herein.

Giffels Webster has been asked to facilitate the requested easement. If you should have any questions, please do not hesitate to contact me at (P) 313.962.4442 (M) 313.980.1469 or mmarks@giffelswebster.com.

Respectfully,

A handwritten signature in cursive script, appearing to read "Michael Marks".

Michael Marks P.E.,
Partner
Giffels Webster

CITY CLERK 31 MAY 2018 AM 9:17

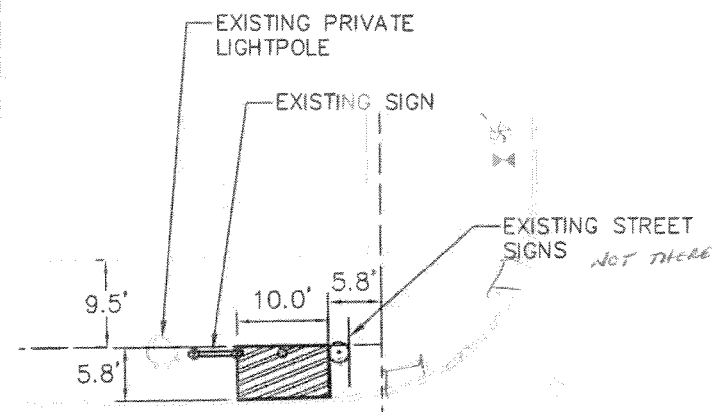

HENRY STREET
 (VACATED WITH
 EASEMENT RETAINED)
 100 FT. WD.

SECOND AVENUE
 (100 FT. WD.)

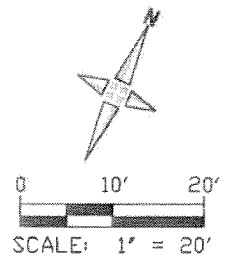

 FLAGPOLE AND CONCRETE
 FOUNDATION ENCROACHING
 INTO THE HENRY STREET
 RIGHT OF WAY

FLAGPOLE FOUNDATION
 ENCROACHMENT
 05/29/2018
 18275-114D

Model EC50 IH



Single sheave truck, cast aluminum revolving, non-fouling, internal halyard truck

1/8" x 7x19 Mil-C-5424 Stainless steel aircraft cable

Standard flag arrangement: 10' x 15'

Neoprene coated 2" diameter steel counterweight

Nylon beaded retainer ring

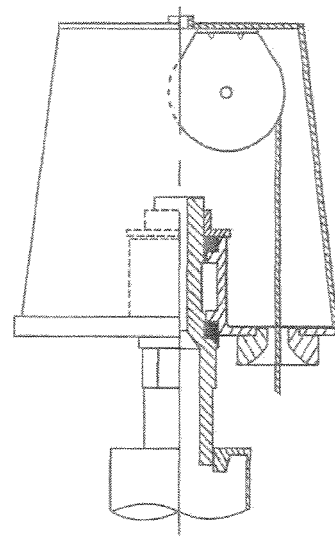

Revolving non-fouling internal halyard truck, cast aluminum body, 26 stainless steel ball bearings, and 2-1/2" diameter plated steel sheave.

Gearless, self locking direct drive winch with six tumbler cylinder lock

Aluminum flash collar

3000 PSI concrete

Hardwood wedges (supplied by others)

Dry sand tightly tamped after aligning pole

Foundation sleeve -16 ga hot dip galvanized steel

Steel centering wedges

1/4" Steel base plate

1/4" Steel support plate welded to grounding spike

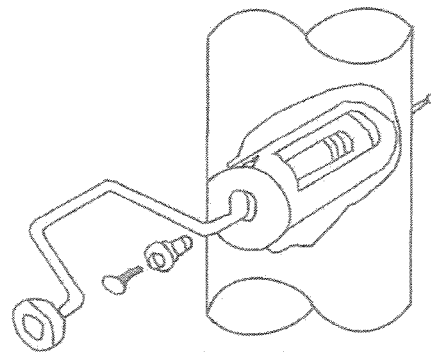
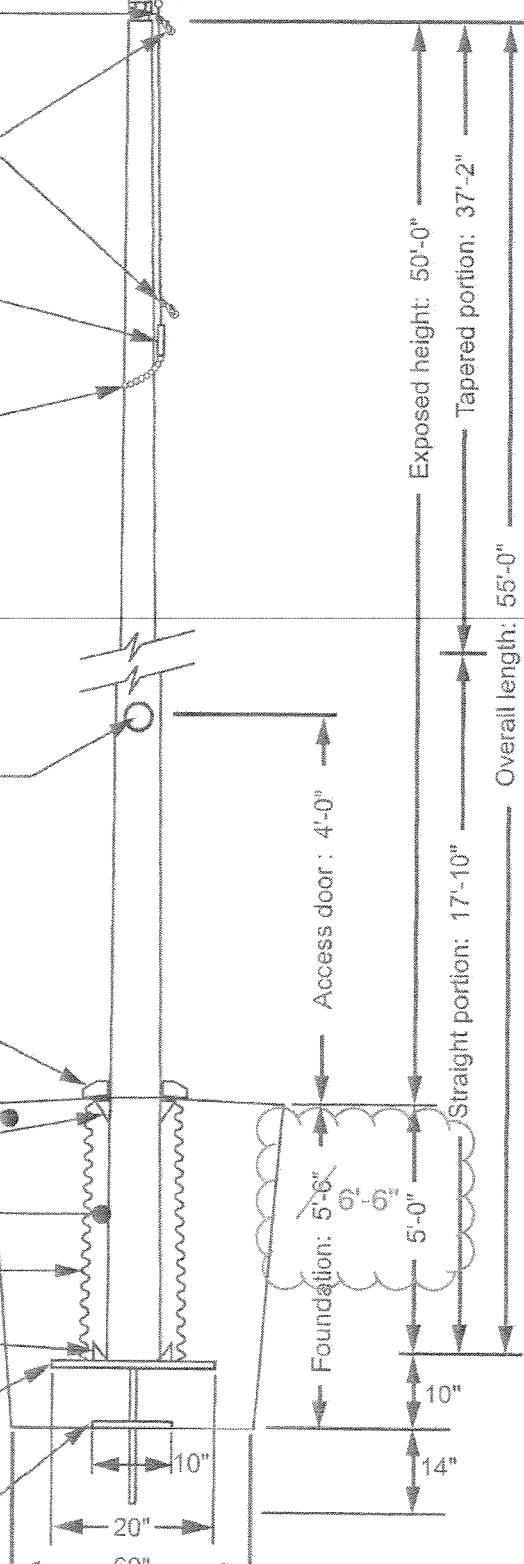

Winch Detail

All shafts with overall length of more than 38'-6" are shipped in two sections.

Each section matched marked for field assembly. Exposed portion of jam sleeve must be well lubricated prior to assembly.

1-1/2" maximum shop gap allowed for field fitting (ram for tight joint)



Project:	Ground set tapered aluminum flagpole: ALLOY: 6063T6	EDER FLAG	Date:
Location:	Exposed height: 50'-0"	Overall height: 55'-0"	MANUFACTURING COMPANY
Architect:	Ship in 3 sections	Butt diameter: 10"	1000 W. Rawson Avenue
Contractor:	Top diameter: 4"	Wall thickness: .188"	Oak Creek, WI 53154
Customer:	Finish: 100 grit polish		Job:

PETITION NO. 371
 THE DETROIT PUBLIC SCHOOLS COMMUNITY DISTRICT
 C/O GIFFELS WEBSTER
 28 W. ADAMS, SUITE 1200
 DETROIT, MICHIGAN 48226
 C/O MICHAEL MARKS P.E.
 PHONE NO. 313 962-4442



LEDYARD ST. 100 FT. WD.

THIRD AVE. 70 FT. WD.

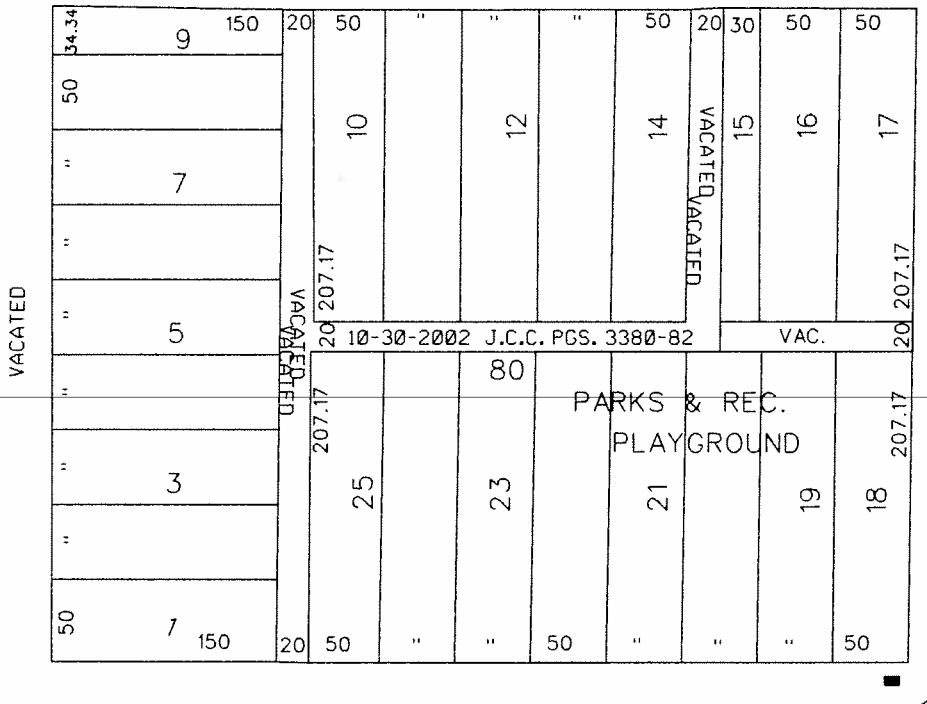

SECOND BLVD. 100 FT. WD.

HENRY ST. 100 FT. WD.

EASEMENT

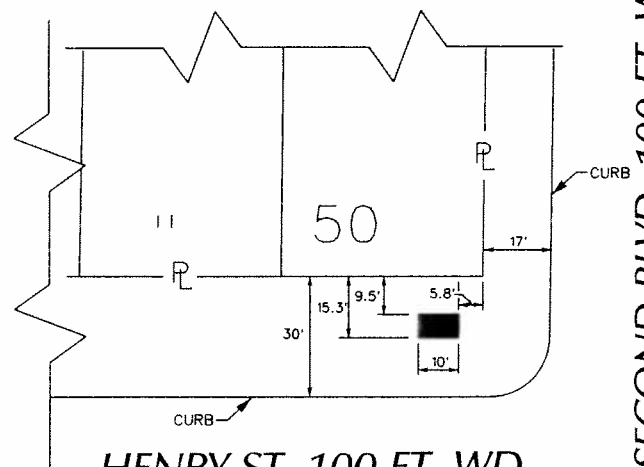

SECOND BLVD. 100 FT. WD.

HENRY ST. 100 FT. WD.

EASEMENT

CARTO 29 E

 - REQUEST ENCROACHMENT
 (With Concrete Foundation and Flag Pole)

(FOR OFFICE USE ONLY)

B					
A					
DESCRIPTION		DRWN	CHKD	APPD	DATE
REVISIONS					
DRAWN BY	WLW	CHECKED	KSM		
DATE	07-03-18	APPROVED			

**REQUEST ENCROACHMENT
 INTO HENRY
 AT 2501 SECOND BLVD.
 (With Concrete Foundation and Flag Pole)**

CITY OF DETROIT	
CITY ENGINEERING DEPARTMENT	
SURVEY BUREAU	
JOB NO.	01-01
DRWG. NO.	X 371