

City of Detroit
OFFICE OF THE CITY CLERK

Janice M. Winfrey
City Clerk

Vivian A. Hudson
Deputy City Clerk

DEPARTMENTAL REFERENCE COMMUNICATION

Thursday, May 31, 2018

To: The Department or Commission Listed Below
From: Janice M. Winfrey, Detroit City Clerk

The following petition is herewith referred to you for report and recommendation to the City Council.

In accordance with that body's directive, kindly return the same with your report in duplicate within four (4) weeks.

DPW - CITY ENGINEERING DIVISION
PLANNING AND DEVELOPMENT DEPARTMENT

371 The Detroit Public Schools Community District, request to encroach into a vacated Right of Way converted to public easement

6/29/18 - EMAILED MR. MARKS ON GETTING ELEVATION PLANS FOR THE CURB & FOUNDATION & FLAG POLE. HE IS IN THE PROCESS OF GETTING THE DOCUMENTATION.

~~He also...~~

5/13/17 - LEFT EMAIL WITH MR. MARKS TO GET THE STATUS OF THIS PETITION REQUEST (I.E., REACHING OUT TO PLO)

6/6/17 - TALKED TO MR. CLAWFORD (PLO) ABOUT RESPONDING

200 Coleman A. Young Municipal Center • Detroit, Michigan 48226-3400

(313) 224 3260 • Fax (313) 224-1466

TO PETITIONER'S FASTER. HE SAID THAT HE IS GOING TO RESPOND TO THIS ONE SOON.

→ OVER →

29 E

3



May 29, 2018

HAND DELIVER

**Honorable Detroit City Council
C/o Detroit City Clerk
200 Coleman A. Young Municipal Center
2 Woodward Avenue
Detroit, Michigan 48226**

RE: Giffels Webster - Request to encroach into a vacated Right of Way converted to public easement.

Giffels Webster, 28 W. Adams, Suite 1200, Detroit, Michigan 48226 on behalf of The Detroit Public Schools Community District, 1601 Farnsworth, Detroit, MI, 48211 respectfully requests the following encroachment into a City of Detroit vacated public right of way converted to easement:

- A flagpole and its concrete foundation encroaching into the vacated Henry Street right of way (100 feet wide) converted to public easement located just west of Second Avenue (100 feet wide). This encroachment extends 5.8 feet into the vacated Henry Street easement.

Limits of the requested easement can be found in the attachment, enclosed herein.

Giffels Webster has been asked to facilitate the requested easement. If you should have any questions, please do not hesitate to contact me at (P) 313.962.4442 (M) 313.980.1469 or mmarks@giffelswebster.com.

Respectfully,

A handwritten signature in dark ink, appearing to read "Michael A. Marks".

Michael Marks P.E.,
Partner
Giffels Webster

CITY CLERK 31 MAY 2018 AM 9:17

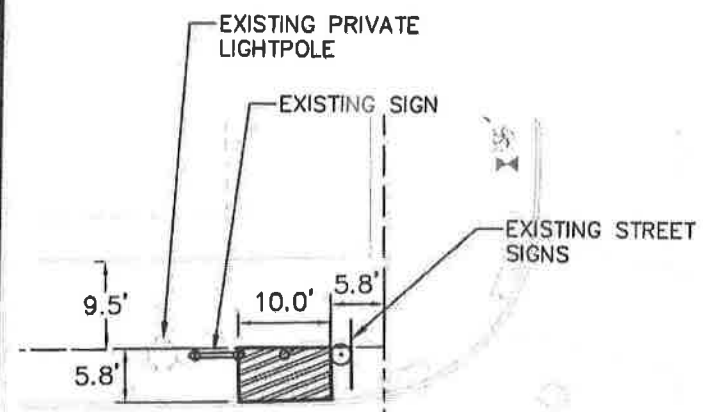

HENRY STREET
 (VACATED WITH
 EASEMENT RETAINED)
 100 FT. WD.

SECOND AVENUE
 (100 FT. WD.)

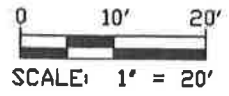

 FLAGPOLE AND CONCRETE
 FOUNDATION ENCROACHING
 INTO THE HENRY STREET
 RIGHT OF WAY

FLAGPOLE FOUNDATION
 ENCROACHMENT
 05/29/2018
 18275-114D

2018-05-31

371

371 *Petition of The Detroit Public Schools
Community District, request to
encroach into a vacated Right of Way
converted to public easement*

REFERRED TO THE FOLLOWING DEPARTMENT(S)

DPW - CITY ENGINEERING DIVISION
PLANNING AND DEVELOPMENT DEPARTMENT

Model EC50 IH

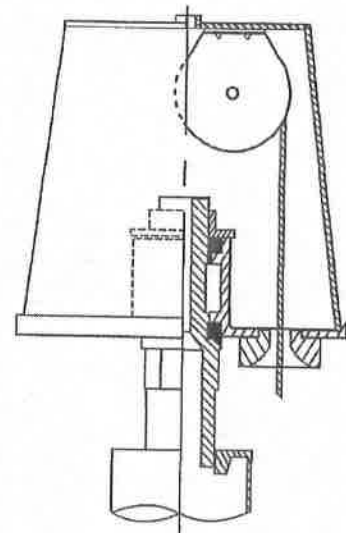
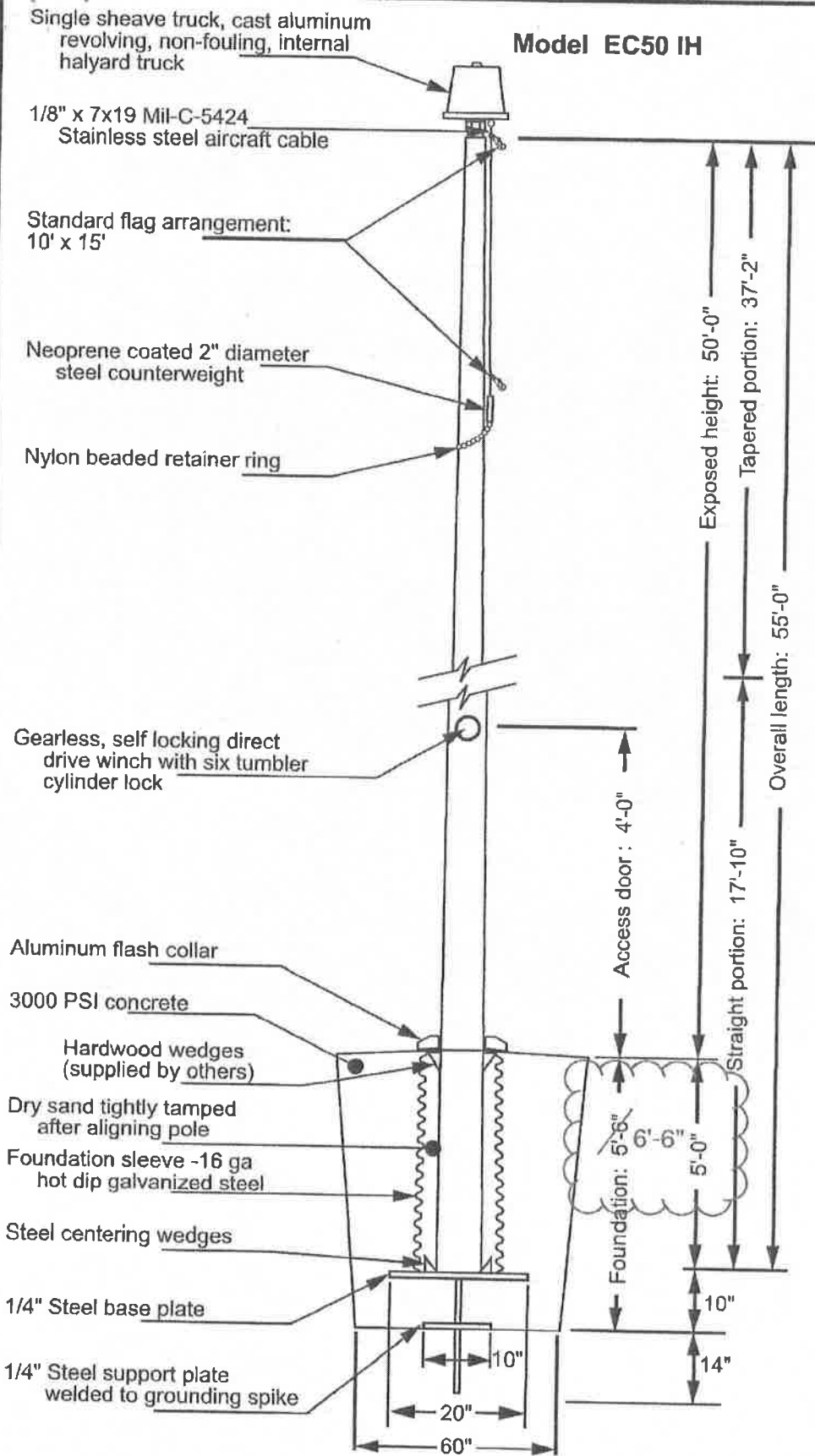

Revolving non-fouling internal halyard truck, cast aluminum body, 26 stainless steel ball bearings, and 2-1/2" diameter plated steel sheave.

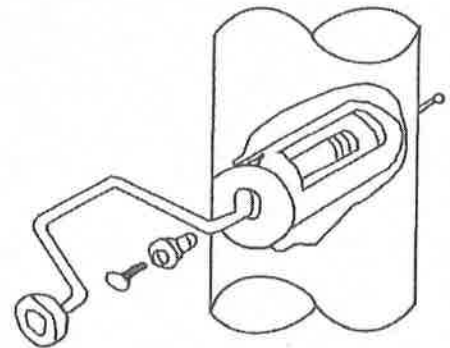

Winch Detail

All shafts with overall length of more than 38'-6" are shipped in two sections.

Each section matched marked for field assembly. Exposed portion of jam sleeve must be well lubricated prior to assembly.

1-1/2" maximum shop gap allowed for field fitting (ram for tight joint)

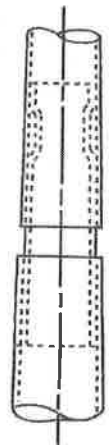

Project:	Ground set tapered aluminum flagpole: ALLOY: 6063T6	EDER FLAG	Date:
Location:	Exposed height: 50'-0"	Overall height: 55'-0"	Revision:
Architect:	Ship in 3 sections	Bull diameter: 10"	MANUFACTURING COMPANY
Contractor:	Top diameter: 4"	Wall thickness: .188"	1000 W. Rawson Avenue
Customer:	Finish: 100 grit polish	Oak Creek, WI 53154	Job: