

City of Detroit
**City Engineering Division, Department of Public Works
Survey Bureau**

NOTICE OF PROPOSED CHANGE IN PROPERTY

Date: 07/30/2018

Petition: x349

- | | |
|---|--|
| <input type="checkbox"/> AT&T Telecommunication | <input type="checkbox"/> Berm Use |
| <input type="checkbox"/> Comcast Television (CATV) | <input type="checkbox"/> Conversion to Easement |
| <input type="checkbox"/> Detroit Edison (DTE) | <input type="checkbox"/> Dedication |
| <input type="checkbox"/> Fire Department | <input checked="" type="checkbox"/> Encroachment |
| <input type="checkbox"/> Great Lakes Water Authority | <input type="checkbox"/> Outright Vacation |
| <input type="checkbox"/> Land Bank Authority | <input type="checkbox"/> Temporary Closing |
| <input type="checkbox"/> Michcon (DTE) | |
| <input checked="" type="checkbox"/> Planning & Development Department | |
| <input type="checkbox"/> Public Lighting Authority | |
| <input type="checkbox"/> Public Lighting Department | |
| <input type="checkbox"/> Police Department | |
| <input type="checkbox"/> Solid Waste Division, DPW | |
| <input type="checkbox"/> Street Design Bureau, DPW | |
| <input type="checkbox"/> Street Maintenance Division, DPW | |
| <input type="checkbox"/> Traffic Engineering Division, DPW | |
| <input type="checkbox"/> Water and Sewerage Department | |
| <input type="checkbox"/> _____ | |

A petition drawing is attached. Property shown on the attached print is proposed to be changed as indicated. Kindly report (using the back of this sheet) the nature of your services, if any affected by the proposed change and the estimated costs of removing and rerouting such services (if necessary).

Please return one copy to City Engineering Division, DPW within two weeks of the submittal date. Retain one copy and print for you file.

Ron Brundidge, Director, Department of Public Works

By: Richard Doherty, CED DPW
City Engineer

**TO: City Engineering Division, DPW
2 Woodward Ave., Suite 642
Detroit, Michigan 48226-3462
Survey Bureau: 313-224-3970**

Petition: x349

The proposed change in property (referred to on the other side of this sheet) would affect our services as follows:

- Not Involved
- Involved; but asking you to hold action on this petition until further notice.
- Involved; but no objections to the property change.
A 6' unobstructed pedestrian clearance should be provided between the outdoor seating fencing and the existing light pole and parking kiosk. The Chief Operating Officer for the City of Detroit reserves the right to revoke approval. P&DD does not support a permanent encroachment and recommends a duration of 3-5 years.
- Involved; objection to the property change.
- Involved; but no objections to the property change...provided as easement of the full width of the public right-of-way (street, alley or other public place) is reserved.
- Involved; the nature of our services and the estimated costs of removing and/or rerouting such services are:

Planning & Development Department
(Utility or City Department)



By

Greg Moots-Lead Planner-Office of Zoning Innovation
Title

Oct 13, 18
Date

313-224-1358
Area code -- Telephone number

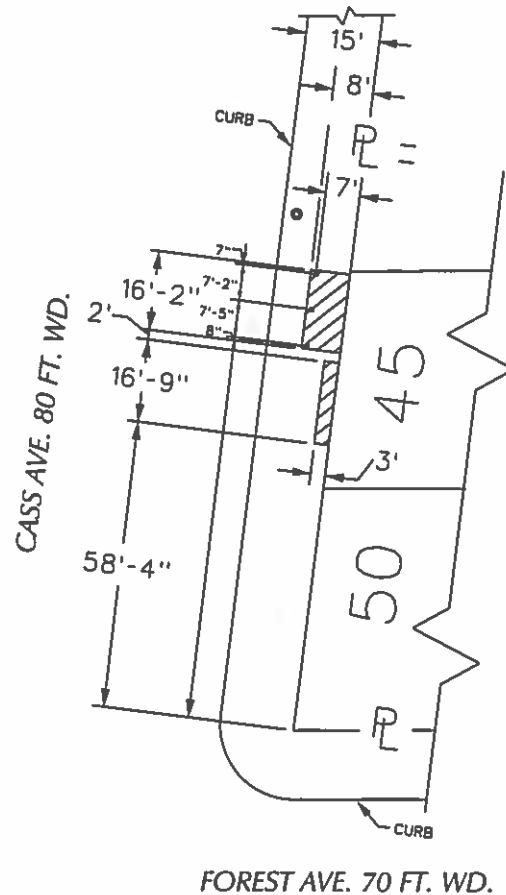
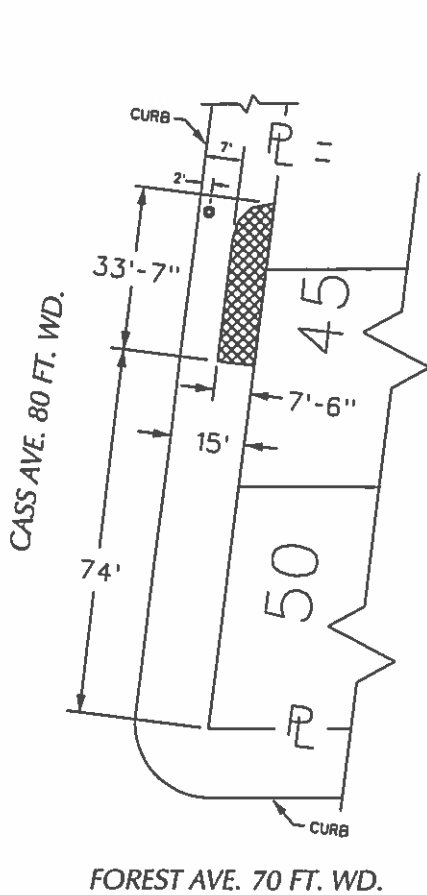
PETITION NO. 349
 CHOLADA CHAN
 4710 CASS AVE.
 DETROIT, MICHIGAN 48201
 C/O ERIC CHUA
 PHONE NO. 248 880-6833



- Steel Tube
- ⊙ Light pole

- REQUEST ENCROACHMENT (At Grade to 8 Feet)

- REQUEST ENCROACHMENT (With Outdoor Seating)

CASS AVE. 80 FT. WD.	45	41.65	40	H	154.24	15	30	-	-	-	30	18	44	181.77	43	44.05
	-	-	-	G	-	15	52	50	48	46	44	15	44	-	-	-
	-	-	-	F	-	15	167	-	-	-	-	15	44	41	-	-
	-	-	-	E	-	15	20	-	-	-	-	15	45	40	-	-
	-	-	-	D	SUB'N	-	15	167	-	-	-	15	45	39	-	-
	-	-	-	C	-	15	167	-	-	-	-	15	45	13TH	-	-
	-	-	-	B	-	15	27	29	31	33	35	15	44	144.20	-	-
	-	-	-	A	-	15	30	-	-	-	-	15	44	37	36	37.87
	-	-	-	-	-	15	30	-	-	-	-	15	44	140.22	-	6.21
	-	-	-	-	-	15	30	-	-	-	-	15	44	22.04	-	-

(FOR OFFICE USE ONLY)

CARTO 30 E

B					
A					
DESCRIPTION		DRWN	CHEK	APPD	DATE
REVISIONS					
DRAWN BY	WLW	CHECKED	KSM		
DATE	07-30-18	APPROVED			

REQUEST ENCROACHMENT INTO CASS AT 4710 CASS AVE.
 (With Outdoor Seating and Canopies)

CITY OF DETROIT	
CITY ENGINEERING DEPARTMENT	
SURVEY BUREAU	
JOB NO.	01-01
DRWG. NO.	X 349

