



City of Detroit  
Inter-Departmental Communication

---

**TO:** Richard Doherty, City Engineer  
City Engineering/Department of Public Works

**FROM:** Debra Singleton, Engineer  
Detroit Water and Sewerage Department

**DATE:** May 23, 2019

**RE:** Petition No.338  
Requested Encroachment Into Woodward At 1241 Woodward (With Outdoor Seating) Bound By Woodward, State, Griswold, And Grand River

---

We have reviewed the above Petition received by this office. With regard to DWSD's interests, our comments are as follows:

- DWSD has no objections to the requested encroachments provided that the attached Provisions for Encroachment are strictly followed.

If you have any questions, please call me at (313) 267-8309 or Mohammed Fa Siddique at (313)-964-9245.

Sincerely,

Debra Singleton  
Engineer  
Permits

DS/MS/gl

Attachments

CC: Mohamad Farhat, CSF

Michael Duggan, Mayor

City of Detroit  
**City Engineering Division, Department of Public Works**  
**Survey Bureau**

**NOTICE OF PROPOSED CHANGE IN PROPERTY**

Date: 05/17/2019

Petition: x338

- |  |  |
|--|--|
| <input type="checkbox"/> AT&T Telecommunication            | <input type="checkbox"/> Berm Use                |
| <input type="checkbox"/> Comcast Television (CATV)         | <input type="checkbox"/> Conversion to Easement  |
| <input type="checkbox"/> Detroit Edison (DTE)              | <input type="checkbox"/> Dedication              |
| <input type="checkbox"/> Fire Department                   | <input checked="" type="checkbox"/> Encroachment |
| <input type="checkbox"/> Great Lakes Water Authority       | <input type="checkbox"/> Outright Vacation       |
| <input type="checkbox"/> Land Bank Authority               | <input type="checkbox"/> Temporary Closing       |
| <input type="checkbox"/> Michcon (DTE)                     |  |
| <input type="checkbox"/> Planning & Development Department |  |
| <input type="checkbox"/> Public Lighting Authority         |  |
| <input type="checkbox"/> Public Lighting Department        |  |
| <input type="checkbox"/> Police Department                 |  |
| <input type="checkbox"/> Solid Waste Division, DPW         |  |
| <input type="checkbox"/> Street Design Bureau, DPW         |  |
| <input type="checkbox"/> Street Maintenance Division, DPW  |  |
| <input type="checkbox"/> Traffic Engineering Division, DPW |  |
| <input type="checkbox"/> Water and Sewerage Department     |  |
| <input type="checkbox"/> _____                             |  |

A petition drawing is attached. Property shown on the attached print is proposed to be changed as indicated. Kindly report (using the back of this sheet) the nature of your services, if any affected by the proposed change and the estimated costs of removing and rerouting such services (if necessary).

Please return one copy to City Engineering Division, DPW within two weeks of the submittal date. Retain one copy and print for you file.

Ron Brundidge, Director, Department of Public Works

By: Richard Doherty, CED DPW  
City Engineer

**TO: City Engineering Division, DPW  
2 Woodward Ave., Suite 642  
Detroit, Michigan 48226-3462  
Survey Bureau: 313-224-3970**

**Petition: x338**

The proposed change in property (referred to on the other side of this sheet) would affect our services as follows:

- Not Involved
  
- Involved; but asking you to hold action on this petition until further notice.
  
- Involved; but no objections to the property change.
  
- Involved; objection to the property change.
  
- Involved; but no objections to the property change...provided as easement of the full width of the public right-of-way (street, alley or other public place) is reserved.
  
- Involved; the nature of our services and the estimated costs of removing and/or rerouting such services are:

\_\_\_\_\_  
(Utility or City Department)

\_\_\_\_\_  
By

\_\_\_\_\_  
Title

\_\_\_\_\_  
Date

\_\_\_\_\_  
Area code – Telephone number

PETITION NO. 338  
 TEK - ADAMS FOODS, LLC  
 C/O THE HUDSON CAFE  
 18534 MACK AVE.  
 GROSSE POINTE FARMS, MICHIGAN 48236  
 DAVID R. DRAPER, ESQ.  
 PHONE NO. 313 885-6800



**GD. RIVER AVE. 60 FT. WD.**

**GRISWOLD AVE. 60 FT. WD.**

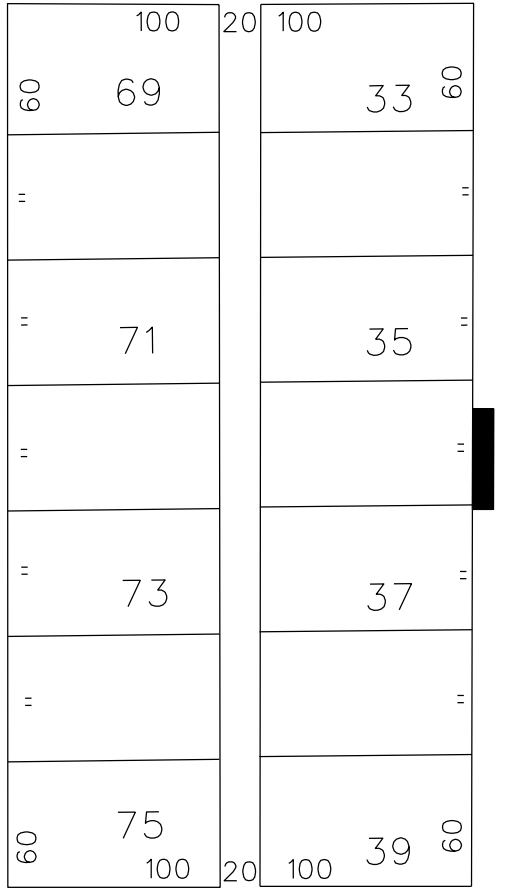

**WOODWARD AVE. 120 FT. WD.**

**STATE ST. 60 FT. WD.**

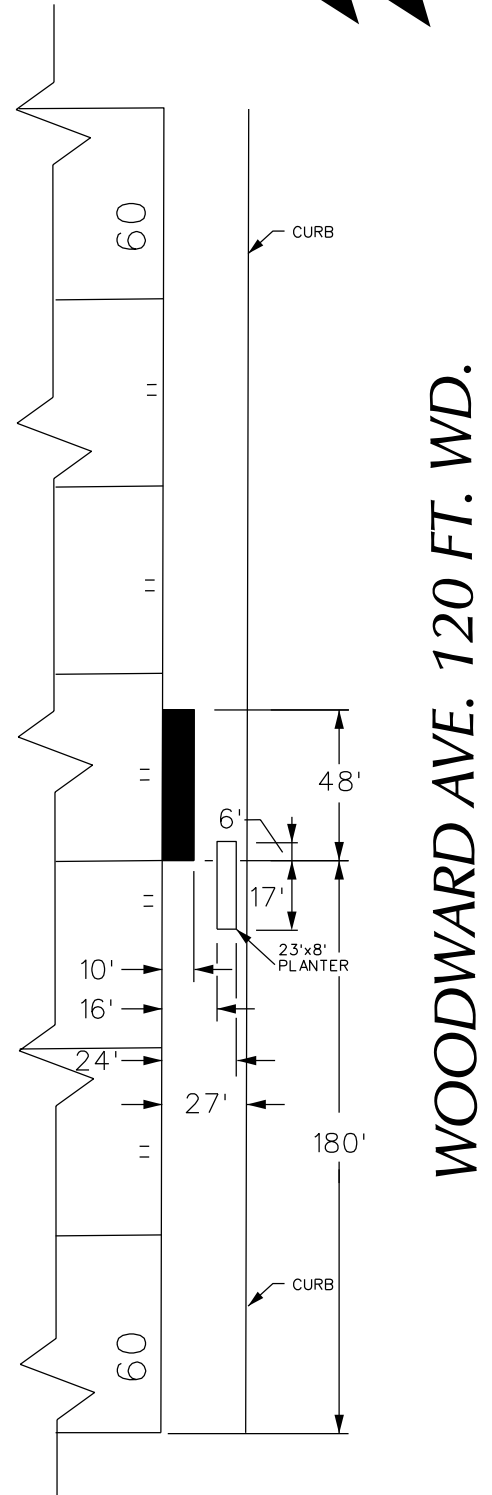

**WOODWARD AVE. 120 FT. WD.**



- REQUEST ENCROACHMENT  
 (With Outdoor Seating)

(FOR OFFICE USE ONLY)

CARTO 28 B

B					
A					
DESCRIPTION	DRWN	CHKD	APPD	DATE	
REVISIONS					
DRAWN BY	WLW	CHECKED	KSM		
DATE	05-16-19	APPROVED			

REQUEST ENCROACHMENT  
 INTO WOODWARD  
 AT 1241 WOODWARD AVE.  
 (With Outdoor Seating)

CITY OF DETROIT  
 CITY ENGINEERING DEPARTMENT  
 SURVEY BUREAU

JOB NO. 01-01

DRWG. NO. X 338

## **PROVISIONS FOR ENCROACHMENT For Petition 338**

Detroit Water and Sewerage (DWSD) agree to the proposed encroachment subject to the fulfilling of the following provisions:

1. By approval of this petition the (DWSD) does not waive any of its rights to its facilities located in the right of way, and at all time, DWSD, its agents or employees, shall have the right to enter upon the right of way to maintain, repair, alter, service, inspect, or install its facilities. All costs incident to the damaging, dismantling, demolishing, removal and replacement of structures or other improvements herein permitted and incurred in gaining access to DWSD's facilities for maintenance, repairing, alteration, servicing or inspection caused by the encroachment shall be borne by the petitioner. All costs associated with gaining access to DWSD's facilities, which could normally be expected had the petitioner not encroached into the right of way shall be borne by DWSD.
2. DWSD requires a vertical clearance of 18 feet above grade for maintenance excess and repair.
3. All construction performed under this petition shall not be commenced until after five (5) days written notice to DWSD. Seventy-two (72) hours notice shall also be provided in accordance with P.A. 53 1974, as amended, utilizing the MISS DIG one call system.
4. Construction under this petition is subject to inspection and approval by DWSD forces. The cost of such inspection shall, at the discretion of DWSD, be borne by the petitioner.
5. If DWSD facilities located within the right of way shall break or be damaged as the result of any action on the part of the petitioner, then in such event the petitioner agrees to be liable for all costs incident to the repair, replacement or relocation of such broken or damaged DWSD facilities.
6. The petitioner shall hold DWSD harmless for any damage to the encroaching device constructed or installed under this petition, which may be caused by the failure of DWSD's facilities.



50' 22" EE  
63' EE

3' MN  
48' 20'  
12' 24'  
8' TSV

6' 12' 48'  
6' 12' 48'  
6' 12' 48'

3' MN  
18' 8'  
12' 8' WW

36' 8'  
28' 6'  
4' MN

10' 6"  
10' 6"  
3' TSV

30' 30' EW  
40' 30' EW

8' TSV  
6' TSV  
8' TSV

8' SERV  
10' SERV

12' DI  
12' SERV  
8' SERV

2' MN  
18' DI  
12' DI

10' 8' DI  
12' 38'  
10' 40'

6' TSV  
3' TSV

10' 12'  
10' 12'  
3' TSV

60' 71'  
10' 8' 8'

36' 32'  
8' DI  
25' MN

32' 4' WW  
12' DI  
12' DI

10' 12'  
10' 12'  
10' 12'

30' SS  
18' 8'  
8' DI

8' TSV  
6' TSV  
8' TSV

8' TSV  
6' TSV  
8' TSV

36' WE  
6' TSV

10' 8' DI  
12' DI  
12' DI

10' 8' DI  
12' DI  
12' DI

10' 8' DI  
12' DI  
12' DI

5' EE  
24' 8' EW

25' 10'  
10' 8' 8'

22' 4' TSV  
4' CLIF  
4' TSV

60' 29' MN  
4' TSV  
MIDDLE ST 6"

6' TSV  
6' TSV  
6' TSV

3' TSV  
3' TSV  
3' TSV

3' TSV  
3' TSV  
3' TSV

3' TSV  
3' TSV  
3' TSV

3' TSV  
3' TSV  
3' TSV

3' TSV  
3' TSV  
3' TSV

3' TSV  
3' TSV  
3' TSV

3' TSV  
3' TSV  
3' TSV

3' TSV  
3' TSV  
3' TSV

12' 10'  
48' 13'  
48' 17'

12' 10'  
48' 13'  
48' 17'

12' 10'  
48' 13'  
48' 17'

12' 10'  
48' 13'  
48' 17'

12' 10'  
48' 13'  
48' 17'

12' 10'  
48' 13'  
48' 17'

12' 10'  
48' 13'  
48' 17'

12' 10'  
48' 13'  
48' 17'

12' 10'  
48' 13'  
48' 17'

12' 10'  
48' 13'  
48' 17'

12' 10'  
48' 13'  
48' 17'

12' 10'  
48' 13'  
48' 17'

12' 10'  
48' 13'  
48' 17'

16" 5'  
30' 20' EW

16" 5'  
30' 20' EW

16" 5'  
30' 20' EW

16" 5'  
30' 20' EW

16" 5'  
30' 20' EW

16" 5'  
30' 20' EW

16" 5'  
30' 20' EW

16" 5'  
30' 20' EW

16" 5'  
30' 20' EW

16" 5'  
30' 20' EW

16" 5'  
30' 20' EW

16" 5'  
30' 20' EW

16" 5'  
30' 20' EW

20' ESMT  
30' 20' EW

20' ESMT  
30' 20' EW

20' ESMT  
30' 20' EW

20' ESMT  
30' 20' EW

20' ESMT  
30' 20' EW

20' ESMT  
30' 20' EW

20' ESMT  
30' 20' EW

20' ESMT  
30' 20' EW

20' ESMT  
30' 20' EW

20' ESMT  
30' 20' EW

20' ESMT  
30' 20' EW

20' ESMT  
30' 20' EW

20' ESMT  
30' 20' EW

16" 4' TSV  
10' ESMT 10'

16" 4' TSV  
10' ESMT 10'

16" 4' TSV  
10' ESMT 10'

16" 4' TSV  
10' ESMT 10'

16" 4' TSV  
10' ESMT 10'

16" 4' TSV  
10' ESMT 10'

16" 4' TSV  
10' ESMT 10'

16" 4' TSV  
10' ESMT 10'

16" 4' TSV  
10' ESMT 10'

16" 4' TSV  
10' ESMT 10'

16" 4' TSV  
10' ESMT 10'

16" 4' TSV  
10' ESMT 10'

16" 4' TSV  
10' ESMT 10'

12' 14'  
48' 17'

12' 14'  
48' 17'

12' 14'  
48' 17'

12' 14'  
48' 17'

12' 14'  
48' 17'

12' 14'  
48' 17'

12' 14'  
48' 17'

12' 14'  
48' 17'

12' 14'  
48' 17'

12' 14'  
48' 17'

12' 14'  
48' 17'

12' 14'  
48' 17'

12' 14'  
48' 17'

28' WE  
22' SN

28' WE  
22' SN

28' WE  
22' SN

28' WE  
22' SN

28' WE  
22' SN

28' WE  
22' SN

28' WE  
22' SN

28' WE  
22' SN

28' WE  
22' SN

28' WE  
22' SN

28' WE  
22' SN

28' WE  
22' SN

28' WE  
22' SN

