

TO: City Engineering Division, DPW
2 Woodward Ave., Suite 642
Detroit, MI 48226-3462
Survey Bureau: 313-224-3970

Petition No. 291

The proposed change in property (referred to above) would affect our services as follows:

- Not Involved.

- Involved; but asking you to hold action on this petition until further notice.
- Involved; the nature of our services, and the estimated costs of removing and/or rerouting such services are:
- Involved; have no objection to request for conversion to easement the west/east public alley, 15 feet wide in the block bound by Michigan Ave., Springwells Ave., Summer and Lumley Ave as shown on drawing no. X 291 dated 12/05/2018 provided that 100% signatures of abutting property owners are secured.

Traffic Engineering Division - DPW
(Utility or City Department)

Ashok Patel Sunny Jacob
By

City Traffic Engineer
Title

January 8, 2019
Date

313 224-1610
Area code-Telephone number

SJ/aa

PETITION NO. 291
 MICHIGAN PROPERTIES, LLC
 7931 MICHIGAN AVE.,
 DETROIT, MICHIGAN 48210
 ALI NASSAR
 PHONE NO. (313) 729-6021



MICHIGAN AVE. 100 FT. WD.

LUMLEY AVE. 50 FT. WD.

SPRINGWELLS AVE. 50 FT. WD.

SUMMER 30 FT. WD.

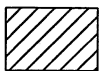
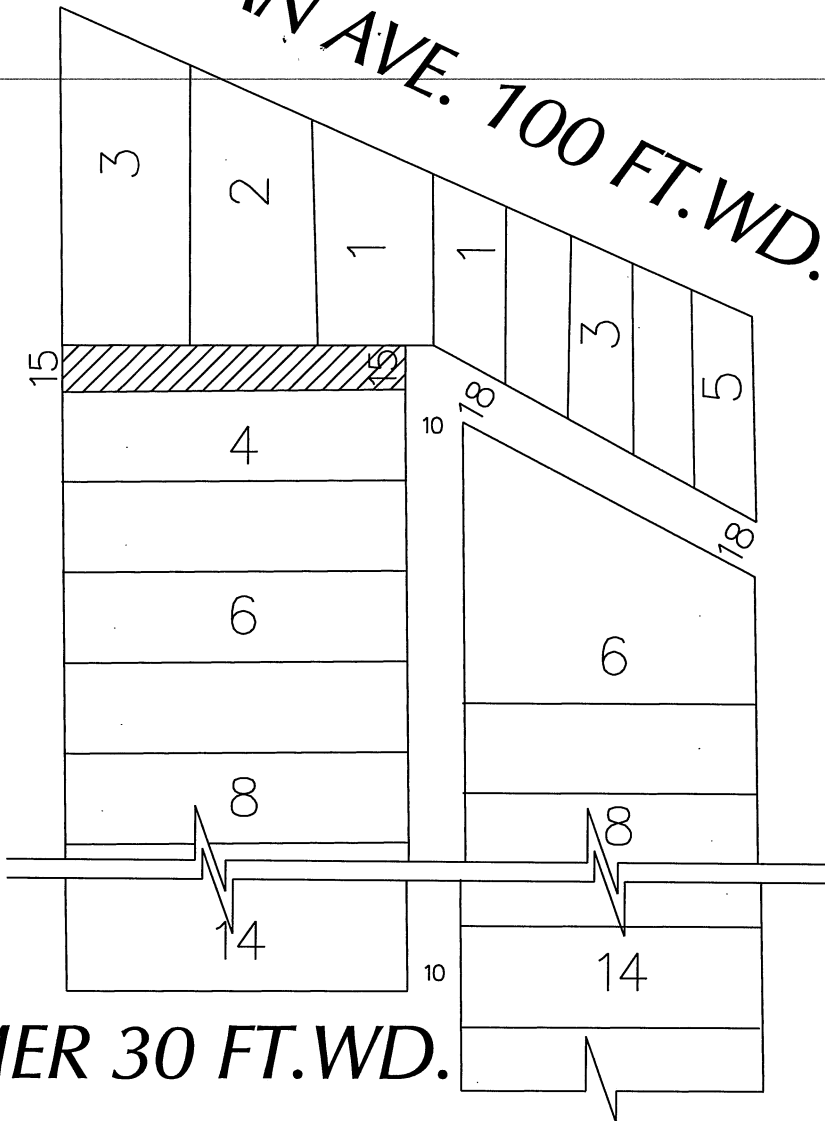

- CONVERSION TO EASEMENT

(FOR OFFICE USE ONLY)

CARTO 4A

B					
A					
DESCRIPTION	DRWN	CHKD	APPD	DATE	
REVISIONS					
DRAWN BY	SA	CHECKED	KSM		
DATE	12-05-18	APPROVED			

CONVERSION TO EASEMENT THE
 WEST/EAST PUBLIC ALLEY, 15 FT. WD.
 IN THE BLOCK BOUND BY
 MICHIGAN AVE., SPRINGWELLS AVE.,
 SUMMER AND LUMLEY AVE.

CITY OF DETROIT CITY ENGINEERING DEPARTMENT SURVEY BUREAU	
JOB NO.	01-01
DRWG. NO.	X 291