

# 291

City of Detroit  
City Engineering Division, Department of Public Works  
Survey Bureau

NOTICE OF PROPOSED CHANGE IN PROPERTY

2nd Notice: 1/14/19

Date: 12/05/2018

Petition: x291

- AT&T Telecommunication
  - Comcast Television (CATV)
  - Detroit Edison (DTE)
  - Fire Department
  - Great Lakes Water Authority
  - Land Bank Authority
  - Michcon (DTE)
  - Planning & Development Department
  - Public Lighting Authority
  - Public Lighting Department
  - Police Department
  - Solid Waste Division, DPW
  - Street Design Bureau, DPW
  - Street Maintenance Division, DPW
  - Traffic Engineering Division, DPW
  - Water and Sewerage Department
  - \_\_\_\_\_
- Berm Use
  - Conversion to Easement
  - Dedication
  - Encroachment
  - Outright Vacation
  - Temporary Closing



A petition drawing is attached. Property shown on the attached print is proposed to be changed as indicated. Kindly report (using the back of this sheet) the nature of your services, if any affected by the proposed change and the estimated costs of removing and rerouting such services (if necessary).

Please return one copy to City Engineering Division, DPW within two weeks of the submittal date. Retain one copy and print for you file.

Ron Brundidge, Director, Department of Public Works

By: Richard Doherty, CED DPW  
City Engineer

TO: City Engineering Division, DPW  
2 Woodward Ave., Suite 642  
Detroit, Michigan 48226-3462  
Survey Bureau: 313-224-3970

Petition: x291

The proposed change in property (referred to on the other side of this sheet) would affect our services as follows:

- Not Involved
- Involved; but asking you to hold action on this petition until further notice.
- Involved; but no objections to the property change.
- Involved; objection to the property change.
- Involved; but no objections to the property change...provided as easement of the full width of the public right-of-way (street, alley or other public place) is reserved.
- Involved; the nature of our services and the estimated costs of removing and/or rerouting such services are:

DPW/SMD  
(Utility or City Department)

By Mr. Hestie R Walker

Supervisor  
Title

Jan 11, 2019  
Date

313.224.0018  
Area code – Telephone number

PETITION NO. 291  
 MICHIGAN PROPERTIES, LLC  
 7931 MICHIGAN AVE.,  
 DETROIT, MICHIGAN 48210  
 ALI NASSAR  
 PHONE NO. (313) 729-6021



MICHIGAN AVE. 100 FT. WD.

LUMLEY AVE. 50 FT. WD.

SPRINGWELLS AVE. 50 FT. WD.

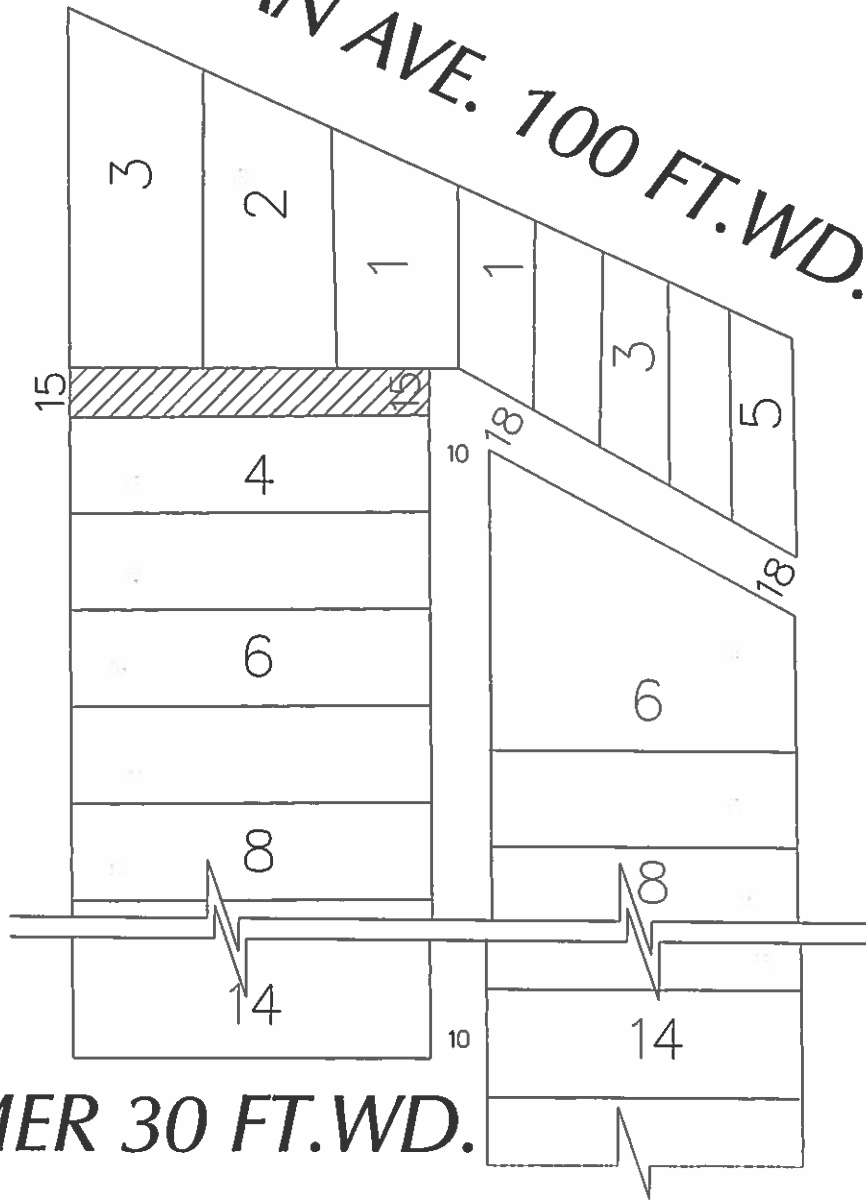

SUMMER 30 FT. WD.



- CONVERSION TO EASEMENT

(FOR OFFICE USE ONLY)

CARTO 4A

|             |          |          |      |      |      |
|-------------|----------|----------|------|------|------|
| B           |          |          |      |      |      |
| A           |          |          |      |      |      |
| DESCRIPTION |          | DRWN     | CHKD | APPO | DATE |
| REVISIONS   |          |          |      |      |      |
| DRAWN BY    | SA       | CHECKED  | KSM  |      |      |
| DATE        | 12-05-18 | APPROVED |      |      |      |

CONVERSION TO EASEMENT THE  
 WEST/EAST PUBLIC ALLEY, 15 FT. WD.  
 IN THE BLOCK BOUND BY  
 MICHIGAN AVE., SPRINGWELLS AVE.,  
 SUMMER AND LUMLEY AVE.

|   |       |
|---|-------|
| CITY OF DETROIT<br>CITY ENGINEERING DEPARTMENT<br>SURVEY BUREAU |       |
| JOB NO.   | 01-01 |
| DRWG. NO.   | X 291 |