

City of Detroit  
**City Engineering Division, Department of Public Works**  
**Survey Bureau**

**NOTICE OF PROPOSED CHANGE IN PROPERTY**

2nd Notice: 1/14/19

Date: 12/05/2018

Petition: x291

- |   |  |
|---|--|
| <input type="checkbox"/> AT&T Telecommunication               | <input type="checkbox"/> Berm Use                          |
| <input type="checkbox"/> Comcast Television (CATV)            | <input checked="" type="checkbox"/> Conversion to Easement |
| <input type="checkbox"/> Detroit Edison (DTE)                 | <input type="checkbox"/> Dedication                        |
| <input type="checkbox"/> Fire Department                      | <input type="checkbox"/> Encroachment                      |
| <input type="checkbox"/> Great Lakes Water Authority          | <input type="checkbox"/> Outright Vacation                 |
| <input type="checkbox"/> Land Bank Authority                  | <input type="checkbox"/> Temporary Closing                 |
| <input type="checkbox"/> Michcon (DTE)                        |  |
| <input type="checkbox"/> Planning & Development Department    |  |
| <input checked="" type="checkbox"/> Public Lighting Authority |  |
| <input type="checkbox"/> Public Lighting Department           |  |
| <input type="checkbox"/> Police Department                    |  |
| <input type="checkbox"/> Solid Waste Division, DPW            |  |
| <input type="checkbox"/> Street Design Bureau, DPW            |  |
| <input type="checkbox"/> Street Maintenance Division, DPW     |  |
| <input type="checkbox"/> Traffic Engineering Division, DPW    |  |
| <input type="checkbox"/> Water and Sewerage Department        |  |
| <input type="checkbox"/> _____                                |  |

A petition drawing is attached. Property shown on the attached print is proposed to be changed as indicated. Kindly report (using the back of this sheet) the nature of your services, if any affected by the proposed change and the estimated costs of removing and rerouting such services (if necessary).

Please return one copy to City Engineering Division, DPW within two weeks of the submittal date. Retain one copy and print for you file.

Ron Brundidge, Director, Department of Public Works

By: Richard Doherty, CED DPW  
City Engineer

TO: City Engineering Division, DPW  
2 Woodward Ave., Suite 642  
Detroit, Michigan 48226-3462  
Survey Bureau: 313-224-3970

Petition: x291

The proposed change in property (referred to on the other side of this sheet) would affect our services as follows:

- Not Involved
- Involved; but asking you to hold action on this petition until further notice.
- Involved; but no objections to the property change.
- Involved; objection to the property change.
- Involved; but no objections to the property change...provided as easement of the full width of the public right-of-way (street, alley or other public place) is reserved.
- Involved; the nature of our services and the estimated costs of removing and/or rerouting such services are:

Public Lighting Authority  
(Utility or City Department)

Mukesh Patel  
By

Engineer  
Title

2/6/19  
Date

313-324-8290  
Area code – Telephone number

PETITION NO. 291  
 MICHIGAN PROPERTIES, LLC  
 7931 MICHIGAN AVE.,  
 DETROIT, MICHIGAN 48210  
 ALI NASSAR  
 PHONE NO. (313) 729-6021



MICHIGAN AVE. 100 FT. WD.

LUMLEY AVE. 50 FT. WD.

SPRINGWELLS AVE. 50 FT. WD.

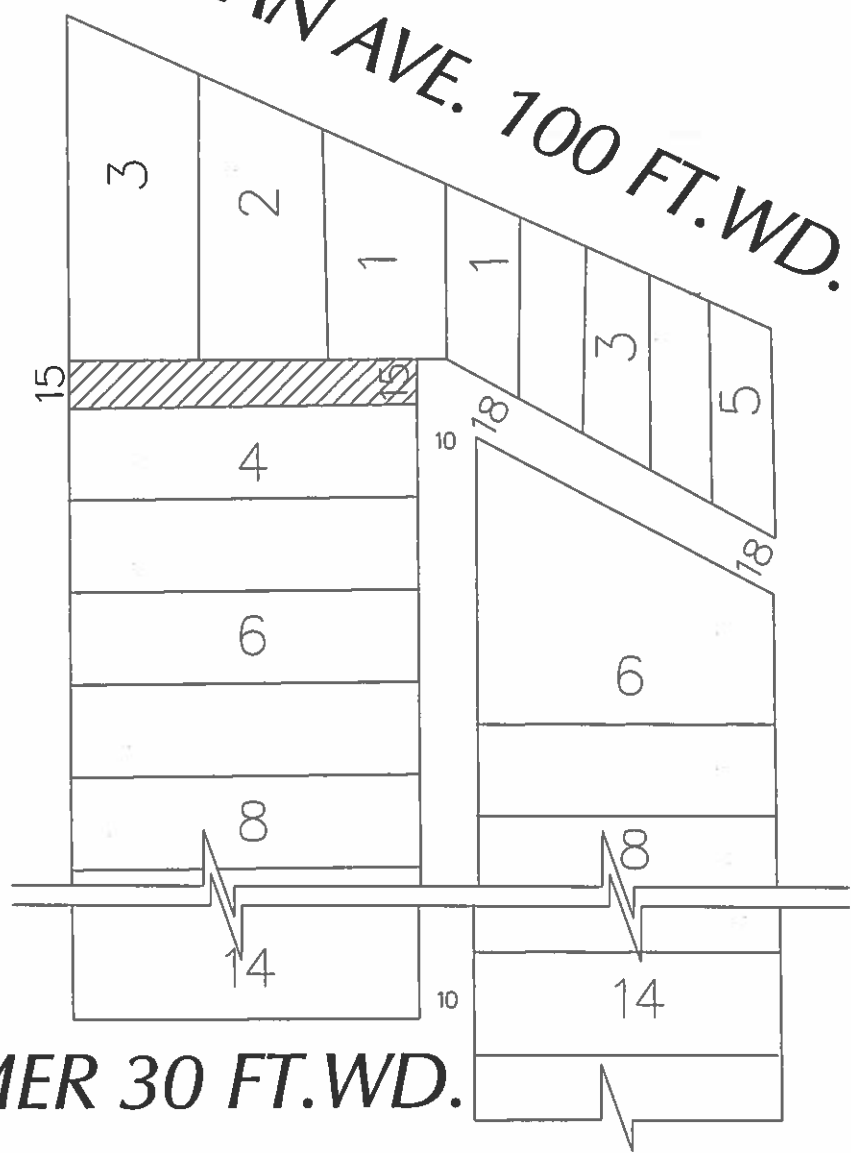

SUMMER 30 FT. WD.

 - CONVERSION TO EASEMENT

(FOR OFFICE USE ONLY)

CARTO 4A

B					
A					
DESCRIPTION	DRWN	CHKD	APPD	DATE	
REVISIONS					
DRAWN BY	SA	CHECKED	KSM		
DATE	12-05-18	APPROVED			

CONVERSION TO EASEMENT THE  
 WEST/EAST PUBLIC ALLEY, 15 FT. WD.  
 IN THE BLOCK BOUND BY  
 MICHIGAN AVE., SPRINGWELLS AVE.,  
 SUMMER AND LUMLEY AVE.

CITY OF DETROIT CITY ENGINEERING DEPARTMENT SURVEY BUREAU	
JOB NO.	01-01
DRWG. NO.	X 291