

To: Deputy Chief Charles Fitzgerald, Neighborhood Policing Bureau- West (Through Channels)

Subject: **NPB – PETITION X291**

From: NPO Juan Lebron, badge 3117, Fourth Precinct

On Thursday, December 6, 2018, I received Petition# X291. I was also instructed to investigate the petition by the due date and report recommendations. The petitioner, Mr. Ali Nassar of the Michigan Properties LLC, stated they would like to Conversion to easement the West/East public alleyway, 15 FT. WD. In the block bound by Michigan Ave, Springwells and Lumley.

On Tuesday, December 11, 2017, at approximately 11:00 AM, I met with the petitioner and canvassed the location. I found this to be an alley that is in the rear of the petitioners business that is located at 7931 Michigan Ave. The petitioner also owns the vacant lot that is South of the petitioned location. The petitioner further stated that he is not trying to close the above location and that it will be completely accessible to the public.

The conversion to easement would not affect E.M.S, Detroit Fire Department, the Detroit Police Department, D.T.E. or the residents that are in the area.



JUAN LEBRON
NPO, Badge #3117
Fourth Precinct

APPROVED
JAN 11 2019

CAPTAIN
FOURTH PRECINCT

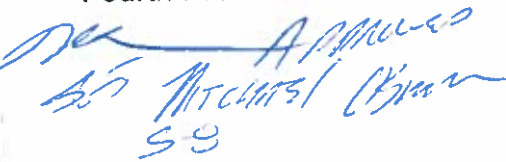
SR

APPROVED
JAN 11 2019

COMMANDER
FOURTH PRECINCT

City of Detroit
City Engineering Division, Department of Public Works
Survey Bureau

NOTICE OF PROPOSED CHANGE IN PROPERTY

Date: 12/05/2018

Petition: x291

- | | |
|--|--|
| <input type="checkbox"/> AT&T Telecommunication | <input type="checkbox"/> Berm Use |
| <input type="checkbox"/> Comcast Television (CATV) | <input checked="" type="checkbox"/> Conversion to Easement |
| <input type="checkbox"/> Detroit Edison (DTE) | <input type="checkbox"/> Dedication |
| <input type="checkbox"/> Fire Department | <input type="checkbox"/> Encroachment |
| <input type="checkbox"/> Great Lakes Water Authority | <input type="checkbox"/> Outright Vacation |
| <input type="checkbox"/> Land Bank Authority | <input type="checkbox"/> Temporary Closing |
| <input type="checkbox"/> Michcon (DTE) | |
| <input type="checkbox"/> Planning & Development Department | |
| <input type="checkbox"/> Public Lighting Authority | |
| <input type="checkbox"/> Public Lighting Department | |
| <input type="checkbox"/> Police Department | |
| <input type="checkbox"/> Solid Waste Division, DPW | |
| <input type="checkbox"/> Street Design Bureau, DPW | |
| <input type="checkbox"/> Street Maintenance Division, DPW | |
| <input type="checkbox"/> Traffic Engineering Division, DPW | |
| <input type="checkbox"/> Water and Sewerage Department | |
| <input type="checkbox"/> _____ | |

A petition drawing is attached. Property shown on the attached print is proposed to be changed as indicated. Kindly report (using the back of this sheet) the nature of your services, if any affected by the proposed change and the estimated costs of removing and rerouting such services (if necessary).

Please return one copy to City Engineering Division, DPW within two weeks of the submittal date. Retain one copy and print for you file.

Ron Brundidge, Director, Department of Public Works

By: Richard Doherty, CED DPW
City Engineer

**TO: City Engineering Division, DPW
2 Woodward Ave., Suite 642
Detroit, Michigan 48226-3462
Survey Bureau: 313-224-3970**

Petition: x291

The proposed change in property (referred to on the other side of this sheet) would affect our services as follows:

- Not Involved
- Involved; but asking you to hold action on this petition until further notice.
- Involved; but no objections to the property change.
- Involved; objection to the property change.
- Involved; but no objections to the property change...provided as easement of the full width of the public right-of-way (street, alley or other public place) is reserved.
- Involved; the nature of our services and the estimated costs of removing and/or rerouting such services are:

DETROIT POLICE
(Utility or City Department)

JUAN LEIBRON
By

eo N.P.O.
Title

1/11/19
Date

313-596-5470
Area code -- Telephone number

PETITION NO. 291
 MICHIGAN PROPERTIES, LLC
 7931 MICHIGAN AVE.,
 DETROIT, MICHIGAN 48210
 ALI NASSAR
 PHONE NO. (313) 729-6021



MICHIGAN AVE. 100 FT. WD.

LUMLEY AVE. 50 FT. WD.

SPRINGWELLS AVE. 50 FT. WD.

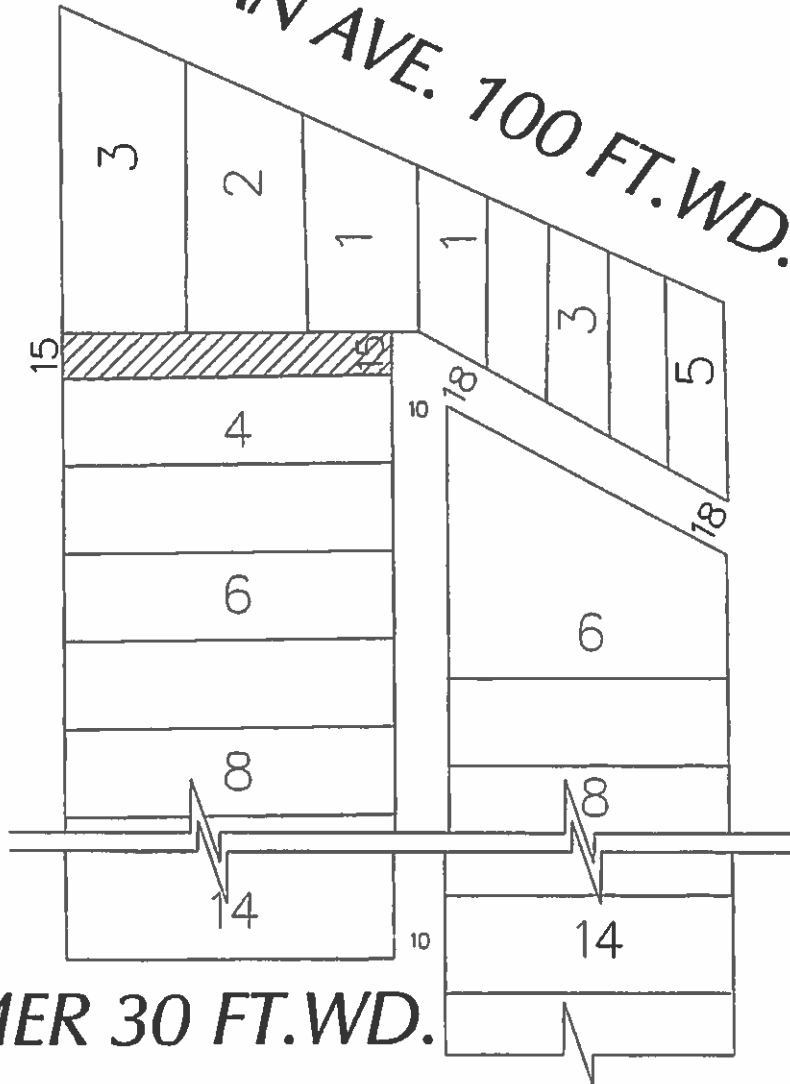

SUMMER 30 FT. WD.



- CONVERSION TO EASEMENT

(FOR OFFICE USE ONLY)

CARTO 4A

B					
A					
DESCRIPTION		DESN	CHKD	APPD	DATE
REVISIONS					
DRAWN BY	SA	CHECKED	KSM		
DATE	12-05-18	APPROVED			

CONVERSION TO EASEMENT THE
 WEST/EAST PUBLIC ALLEY, 15 FT. WD.
 IN THE BLOCK BOUND BY
 MICHIGAN AVE., SPRINGWELLS AVE.,
 SUMMER AND LUMLEY AVE.

CITY OF DETROIT CITY ENGINEERING DEPARTMENT SURVEY BUREAU	
JOB NO.	01-01
DRWG. NO.	X 291