

TO: City Engineering Division, DPW
2 Woodward Ave., Suite 642
Detroit, MI 48226-3462
Survey Bureau: 313-224-3970

Petition No. 0263

The proposed change in property (referred to above) would affect our services as follows:

- () Not Involved.
- () Involved; but asking you to hold action on this petition until further notice.
- () Involved; the nature of our services, and the estimated costs of removing and/or rerouting such services are:
- (X) Involved; have no objection to the requested encroachment into Peterboro at 830 Peterboro St. (with Stairs, Hardscape, Egress Wells, 3rd Floor Balcony and Fencing) as shown on drawing no. x0263 dated 9/17/2018 provided that a minimum 6 ft wide clear unobstructed sidewalk shall be maintained for pedestrian traffic at all times.

Traffic Engineering Division - DPW
(Utility or City Department)

Ashok Patel
By

Sunny Jacob

City Traffic Engineer
Title

November 2, 2018
Date

313 224-1610
Area code-Telephone number

JL/jlrd Floor Balcony

PETITION NO. 263
 830 PETERBORO LLC
 5995 19 MILE RD.
 STERLING HEIGHTS, MICHIGAN 48314
 C/O BILL NUSE III
 PHONE NO. 616 886-1025



MARTIN LUTHER KING JR. BLVD.
 100 FT. WD.

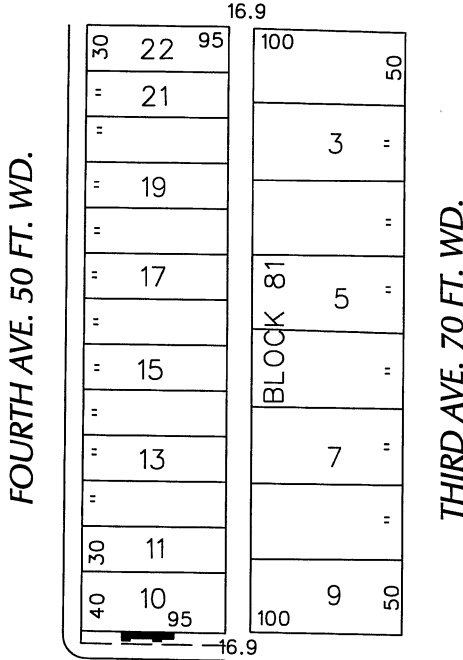

PETERBORO ST. 60 FT. WD.

FOURTH AVE. 50 FT. WD.

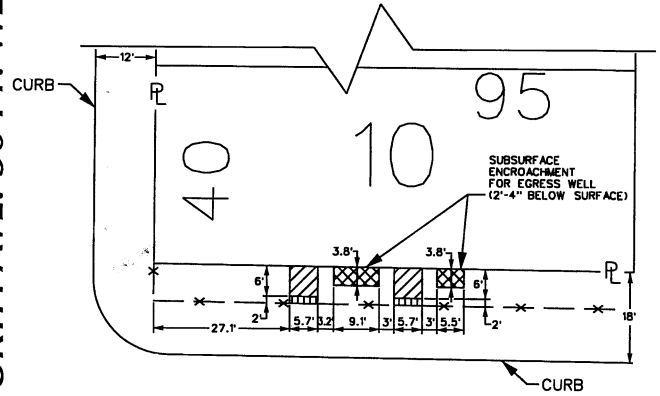

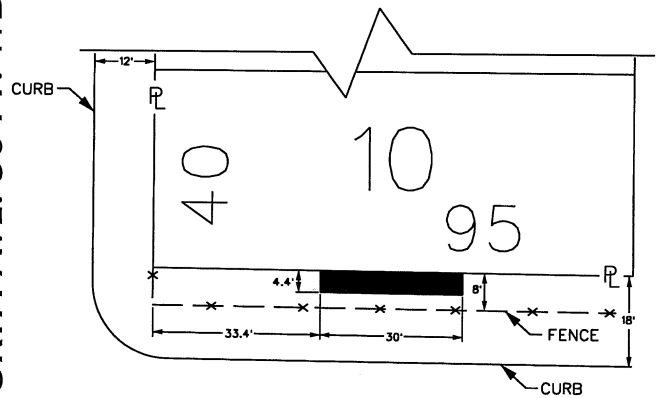

PETERBORO ST. 60 FT. WD.

FOURTH AVE. 50 FT. WD.

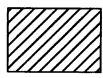
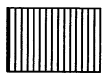
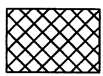

PETERBORO ST. 60 FT. WD.

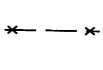
-  - REQUEST ENCROACHMENT (With Existing Stairs)
-  - REQUEST ENCROACHMENT (With Hardscape Brick Walkway)
-  - REQUEST ENCROACHMENT (With Egress Wells)
-  - REQUEST ENCROACHMENT (With 3rd Floor Balcony)
-  - REQUEST ENCROACHMENT (With Perimeter Fence)

(FOR OFFICE USE ONLY)

CARTO 29 B

B					
A					
DESCRIPTION		DRWN	CHKD	APPD	DATE
REVISIONS					
DRAWN BY	WLW	CHECKED		KSM	
DATE	09-17-18	APPROVED			

**REQUEST ENCROACHMENT
 INTO PETERBORO
 AT 830 PETERBORO ST.
 (With Stairs, Hardscape, Egress Wells,
 3rd Floor Balcony and Fencing)**

CITY OF DETROIT	
CITY ENGINEERING DEPARTMENT	
SURVEY BUREAU	
JOB NO.	01-01
DRWG. NO.	X 263