

"REVISED"

City of Detroit
City Engineering Division, Department of Public Works
Survey Bureau

NOTICE OF PROPOSED CHANGE IN PROPERTY

Date: 08/31/2018

Petition: x205

- | | |
|--|--|
| <input type="checkbox"/> AT&T Telecommunication | <input type="checkbox"/> Berm Use |
| <input type="checkbox"/> Comcast Television (CATV) | <input type="checkbox"/> Conversion to Easement |
| <input type="checkbox"/> Detroit Edison (DTE) | <input type="checkbox"/> Dedication |
| <input type="checkbox"/> Fire Department | <input checked="" type="checkbox"/> Encroachment |
| <input type="checkbox"/> Great Lakes Water Authority | <input type="checkbox"/> Outright Vacation |
| <input type="checkbox"/> Land Bank Authority | <input type="checkbox"/> Temporary Closing |
| <input type="checkbox"/> Michcon (DTE) | |
| <input type="checkbox"/> Planning & Development Department | |
| <input type="checkbox"/> Public Lighting Authority | |
| <input type="checkbox"/> Public Lighting Department | |
| <input type="checkbox"/> Police Department | |
| <input type="checkbox"/> Solid Waste Division, DPW | |
| <input type="checkbox"/> Street Design Bureau, DPW | |
| <input type="checkbox"/> Street Maintenance Division, DPW | |
| <input type="checkbox"/> Traffic Engineering Division, DPW | |
| <input type="checkbox"/> Water and Sewerage Department | |
| <input type="checkbox"/> _____ | |

A petition drawing is attached. Property shown on the attached print is proposed to be changed as indicated. Kindly report (using the back of this sheet) the nature of your services, if any affected by the proposed change and the estimated costs of removing and rerouting such services (if necessary).

Please return one copy to City Engineering Division, DPW within two weeks of the submittal date. Retain one copy and print for you file.

Ron Brundidge, Director, Department of Public Works

By: Richard Doherty, CED DPW
City Engineer

TO: City Engineering Division, DPW
2 Woodward Ave., Suite 642
Detroit, Michigan 48226-3462
Survey Bureau: 313-224-3970

Petition: x205
"REVISED"

The proposed change in property (referred to on the other side of this sheet) would affect our services as follows:

- Not Involved
- Involved; but asking you to hold action on this petition until further notice.
- Involved; but no objections to the property change.*
* See highlighted map for details pertaining to the elimination of below grade encroachment shown on DWG x205 per petitioner
- Involved; objection to the property change.
- Involved; but no objections to the property change...provided as easement of the full width of the public right-of-way (street, alley or other public place) is reserved.
- Involved; the nature of our services and the estimated costs of removing and/or rerouting such services are:

DTE Energy

(Utility or City Department)

Chanelle Jones
By  _____

Associate Engineer

Title

10/11/2018

Date

313.235.1549

Area code – Telephone number

PETITION NO. 205
 BEDROCK MANAGEMENT LLC
 C/O GIFFELS WEBSTER
 28 W. ADAMS, SUITE 1200
 DETROIT, MICHIGAN 48226
 C/O MICHAEL MARKS P.E.
 PHONE NO. 313 962-4442

"REVISED"



WOODWARD AVE.
190 FT. WD.

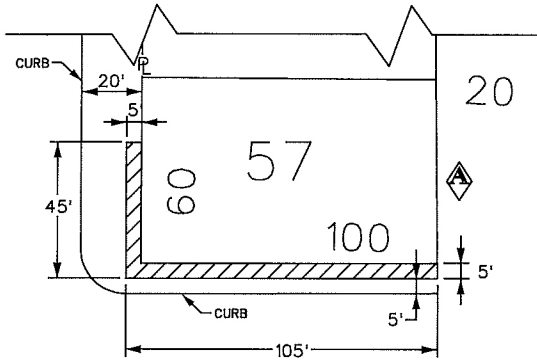

CONGRESS ST. 60 FT. WD.

WOODWARD AVE.
190 FT. WD.

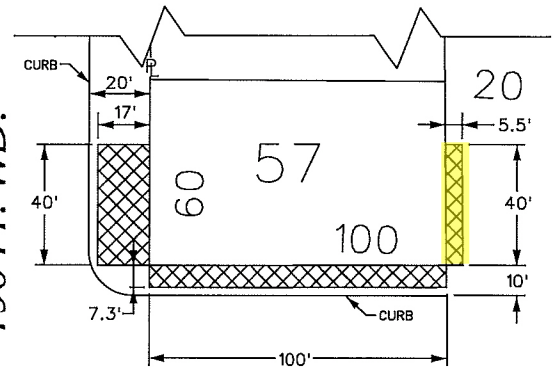

CONGRESS ST. 60 FT. WD.

WOODWARD AVE.
190 FT. WD.

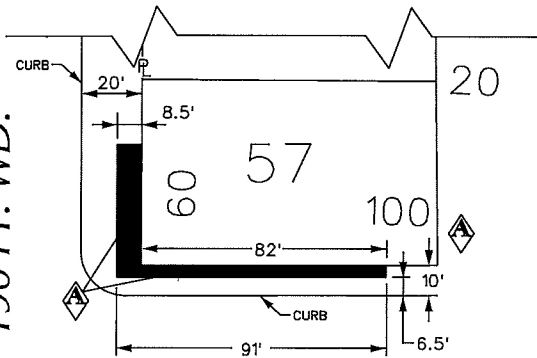

CONGRESS ST. 60 FT. WD.

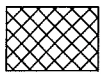

- REQUEST ENCROACHMENT
(Below Ground 0' to -11.5')

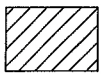

- REQUEST ENCROACHMENT
(Above Ground 8.5' to 172')



- REQUEST ENCROACHMENT
(At Ground Level 0' to 8.5')



10/4/2018 - Per Michael Marks on behalf of petitioner, rear vault abandoned in place in 2014. Petitioner has agreed that this portion of underground encroachment no longer required. - C. Jones, DTE Energy

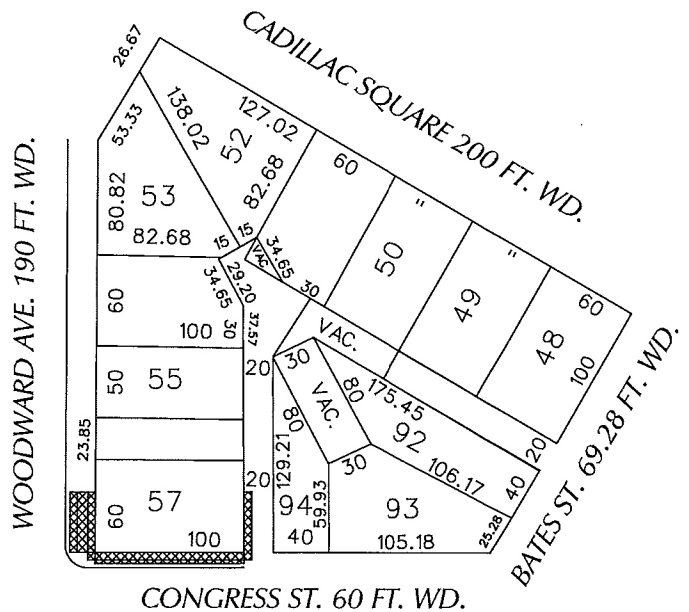

CONGRESS ST. 60 FT. WD.

(FOR OFFICE USE ONLY)

CARTO 28 F

B					
A	ENCROACHMENT ON WOODWARD FROM 12' TO 8.5' REMOVING ENCROACHMENT IN THE ALLIWAY REQUESTING ENCROACHMENT ON CONGRESS FROM 4' TO 13.5'	WLW	KSM	KSM	8/31/18
DESCRIPTION		DRWN	CHKD	APPD	DATE
REVISIONS					
DRAWN BY	WLW	CHECKED		KSM	
DATE	04-19-18	APPROVED			

REQUEST ENCROACHMENT
 INTO WOODWARD, CONGRESS AND A
 PORTION OF THE NORTH/SOUTH PUBLIC ALLEY
 AT 600 WOODWARD AVE.

CITY OF DETROIT	
CITY ENGINEERING DEPARTMENT	
SURVEY BUREAU	
JOB NO.	01-01
DRWG. NO.	X 205