

City of Detroit
City Engineering Division, Department of Public Works
Survey Bureau

NOTICE OF PROPOSED CHANGE IN PROPERTY

Date: 04/26/2018

Petition: x204

- | | |
|---|--|
| <input type="checkbox"/> AT&T Telecommunication | |
| <input type="checkbox"/> Comcast Television (CATV) | <input type="checkbox"/> Berm Use |
| <input type="checkbox"/> Detroit Edison (DTE) | |
| <input type="checkbox"/> Fire Department | <input type="checkbox"/> Conversion to Easement |
| <input type="checkbox"/> Great Lakes Water Authority | |
| <input type="checkbox"/> Land Bank Authority | <input type="checkbox"/> Dedication |
| <input type="checkbox"/> Michcon (DTE) | |
| <input checked="" type="checkbox"/> Planning & Development Department | <input checked="" type="checkbox"/> Encroachment |
| <input type="checkbox"/> Public Lighting Authority | |
| <input type="checkbox"/> Public Lighting Department | <input type="checkbox"/> Outright Vacation |
| <input type="checkbox"/> Police Department | |
| <input type="checkbox"/> Solid Waste Division, DPW | <input type="checkbox"/> Temporary Closing |
| <input type="checkbox"/> Street Design Bureau, DPW | |
| <input type="checkbox"/> Street Maintenance Division, DPW | |
| <input type="checkbox"/> Traffic Engineering Division, DPW | |
| <input type="checkbox"/> Water and Sewerage Department | |
| <input type="checkbox"/> _____ | |

A petition drawing is attached. Property shown on the attached print is proposed to be changed as indicated. Kindly report (using the back of this sheet) the nature of your services, if any affected by the proposed change and the estimated costs of removing and rerouting such services (if necessary).

Please return one copy to City Engineering Division, DPW within two weeks of the submittal date. Retain one copy and print for you file.

Ron Brundidge, Director, Department of Public Works

By: Richard Doherty, CED DPW
City Engineer

**TO: City Engineering Division, DPW
2 Woodward Ave., Suite 642
Detroit, Michigan 48226-3462
Survey Bureau: 313-224-3970**

Petition: x204

The proposed change in property (referred to on the other side of this sheet) would affect our services as follows:

- Not Involved**
Underground encroachment requested along Woodward Ave. will not affect pedestrian circulation. Encroachment at-grade and below-ground in the alley have been removed. Planning has no objection as long as loading and waste services continue to be maintained in the rear of the building and not on any of the surrounding streets.
- Involved; but asking you to hold action on this petition until further notice.**
- Involved; but no objections to the property change.**
- Involved; objection to the property change.**
- Involved; but no objections to the property change...provided as easement of the full width of the public right-of-way (street, alley or other public place) is reserved.**
- Involved; the nature of our services and the estimated costs of removing and/or rerouting such services are:**

City of Detroit-Planning & Development Department
(Utility or City Department)

Greg Moots
By

Greg Moots-Lead Planner-Office of Zoning Innovation
Title

Nov 13, '18
Date

313-224-1358
Area code -- Telephone number

PETITION NO. 204
 BEDROCK MANAGEMENT SERVICES, LLC
 C/O GIFFELS WEBSTER
 28 W. ADAMS, SUITE 1200
 DETROIT, MICHIGAN 48226
 C/O MICHAEL MARKS P.E.
 PHONE NO. 313 962-4442

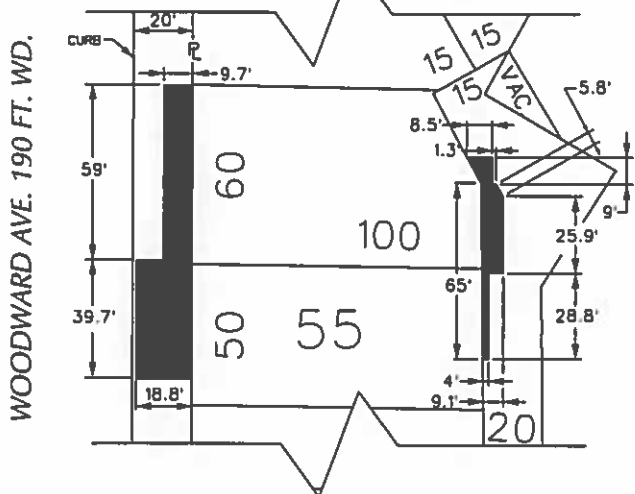
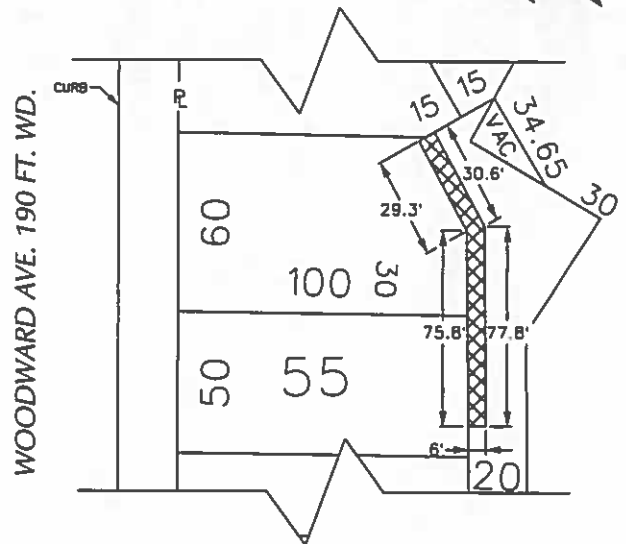
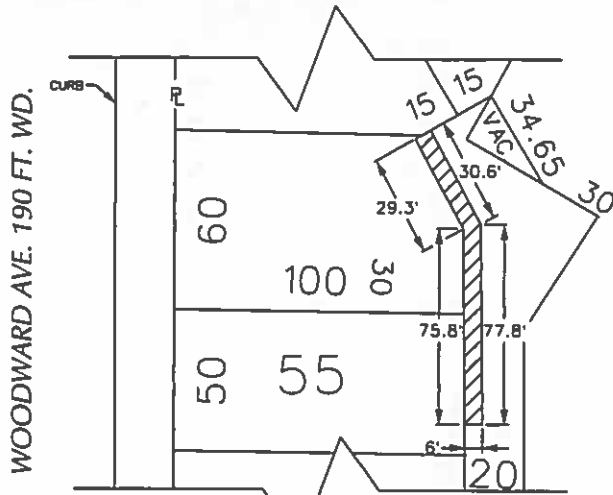

- BREAK LINE
- REQUEST ENCROACHMENT (Above Grade 8.5' to 68.63')
- REQUEST ENCROACHMENT (At Grade 0' to 8.5')
- REQUEST ENCROACHMENT (Below Ground 0' to -11.5')

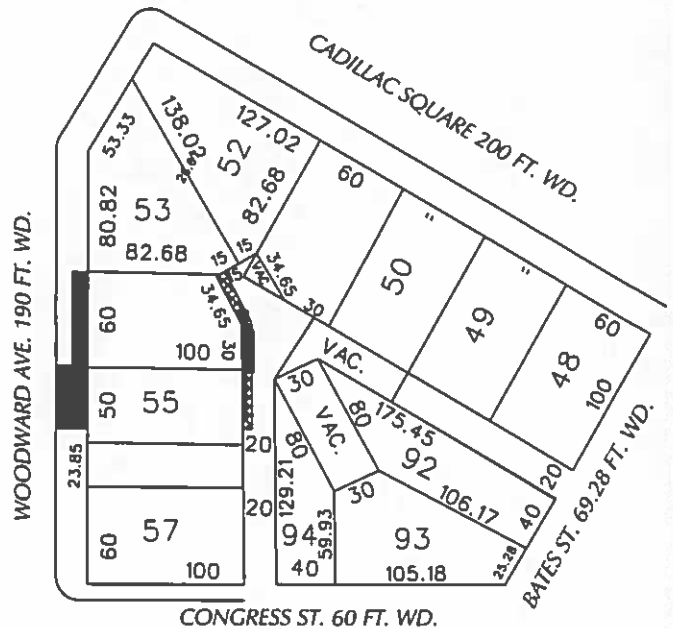

(FOR OFFICE USE ONLY)

CARTO 28 F

B					
A					
DESCRIPTION		DRWN	CHKD	APPD	DATE
REVISIONS					
DRAWN BY	WLW	CHECKED	KSM		
DATE	04-26-18	APPROVED			

REQUEST ENCROACHMENT
 INTO WOODWARD AND A
 PORTION OF THE NORTH/SOUTH PUBLIC ALLEY
 AT 620 and 630 WOODWARD AVE.

CITY OF DETROIT CITY ENGINEERING DEPARTMENT SURVEY BUREAU	
JOB NO.	01-01
DRWG. NO.	X 204

