

TO: City Engineering Division, DPW
2 Woodward Ave., Suite 642
Detroit, MI 48226-3462
Survey Bureau: 313-224-3970

Petition No. 1778REV

The proposed change in property (referred to above) would affect our services as follows:

- () Not Involved.
- () Involved; but asking you to hold action on this petition until further notice.
- () Involved; the nature of our services, and the estimated costs of removing and/or rerouting such services are:
- (X) Involved, have no objection to the request to encroachment a portion of the north/south public alley (with balcony) and into Library and Grand River Ave. (with outdoor seating) at 1274 Library as shown on drawing no. x1778 dated 10/06/2017 and revised on 1/3/2018 provided that a minimum 6 ft wide clear unobstructed sidewalk for pedestrian traffic in front of the outdoor seating area and an additional 2.5 ft of sidewalk width required for accommodating street furniture shall be maintained at all times.

Traffic Engineering Division - DPW
(Utility or City Department)

Ashok Patel
By

Sunny Jacob

City Traffic Engineer
Title

January 12, 2018
Date

313 224-1610
Area code-Telephone number

MA/ma

PETITION NO. 1778
 BEDROCK REAL ESTATE SERVICES, LLC
 C/O GIFFELS WEBSTER
 1092 WOODWARD AVE.
 DETROIT, MICHIGAN 48226
 C/O MICHAEL MARKS
 PHONE NO. 313 962-4442

512-980-1469 (cell)

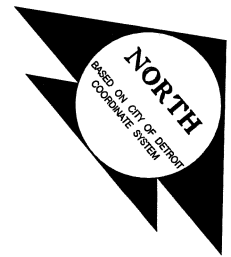

GD. RIVER AVE. 60 FT. WD.

LIBRARY AVE. 71 FT. WD.

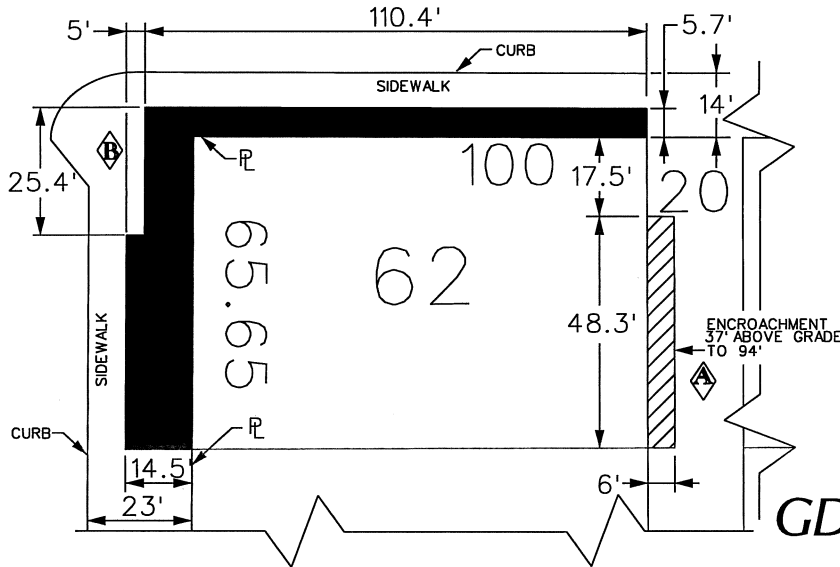

"REVISED"

GD. RIVER AVE. 60 FT. WD.

LIBRARY AVE. 71 FT. WD.

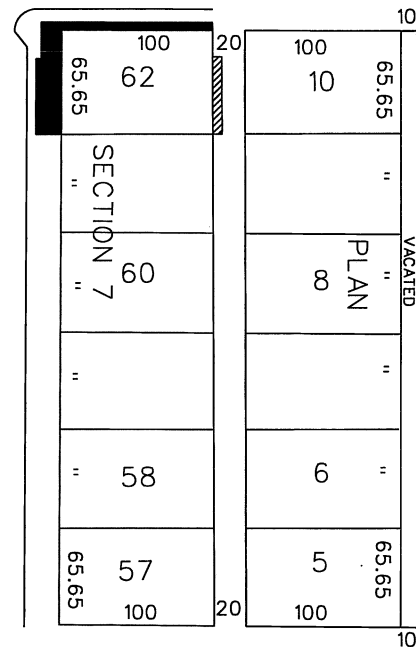

BROADWAY AVE. 100 FT. WD.

GRATIOT AVE. 60 FT. WD.

CARTO 28 A

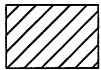

- REQUEST ENCROACHMENT
(With Balcony)



- REQUEST ENCROACHMENT
(With Outdoor Seating)

(FOR OFFICE USE ONLY)

B	CHANGE OUTDOOR SEATING CONFIGURATION ON GD. RIVER AND LIBRARY AVE.	WLW	KSM	KSM	1/03/18
A	CHANGE BALCONY ABOVE GRADE ELEVATION FROM 15 FEET TO 37 FEET IN HEIGHT.	WLW	KSM	KSM	1/03/18
REVISIONS		DRWN	CHKD	APPD	DATE
DRAWN BY	CHECKED				
DATE	APPROVED				

REQUEST ENCROACHMENT
A PORTION OF THE NORTH/SOUTH PUBLIC ALLEY
 (With Balcony)
 AND INTO LIBRARY AND GD. RIVER AVE.
 AT 1274 LIBRARY
 (With Outdoor Seating)

CITY OF DETROIT	
CITY ENGINEERING DEPARTMENT	
SURVEY BUREAU	
JOB NO.	01-01
DRWG. NO.	X 1778