



CITY OF DETROIT
DEPARTMENT OF PUBLIC WORKS
CITY ENGINEERING DIVISION

COLEMAN A. YOUNG MUNICIPAL CENTER
2 WOODWARD AVE. SUITE 601
DETROIT, MICHIGAN 48226
PHONE: (313) 224-3949 • TTY: 711
FAX: (313) 224-3471
WWW.DETROITMI.GOV

January 8, 2020

Honorable City Council:

RE: Petition No. 1697 – Keating Contracting, LLC, request for encroachment permit for installation of new steel canopies on building façade located at 1437 Woodward Avenue.

Petition No. 1697 – Keating Contracting, LLC, request for encroachments with steel canopies on building façades. The encroachments are on the west side of Woodward Avenue, 120 feet wide, between Clifford Avenue, 60 feet wide, and Grand River Avenue, 60 feet wide.

The petition was referred to the City Engineering Division – DPW for investigation and report. This is our report.

The request is being made to upgrade the old building awnings.

The request was approved by the Solid Waste Division – DPW, City Engineering Division – DPW, and Traffic Engineering Division – DPW.

Detroit Water and Sewerage Department (DWSD) reports being involved, but they have no objection provided the DWSD encroachment provisions are followed. The DWSD provisions have been made a part of the resolution.

All other involved City Departments, including the Public Lighting Authority and Public Lighting Department; also privately owned utility companies have reported no objections to the encroachment. Provisions protecting all utility installations are part of the attached resolution.

I am recommending adoption of the attached resolution.

Respectfully submitted,

Richard Doherty, P.E., City Engineer
City Engineering Division – DPW

SW

Cc: Ron Brundidge, Director, DPW
Mayor's Office – City Council Liaison

COUNCIL MEMBER _____

RESOLVED, that the Department of Public Works, City Engineering Division is hereby authorized and directed to issue permits to Keating Contracting, LLC or their assigns to install and maintain encroachments with steel canopies on building façades. The encroachment is on the west side of Woodward Avenue, 120 feet wide, between Clifford Avenue, 60 feet wide, and Grand River Avenue, 60 feet wide and land in the City of Detroit, Wayne County, Michigan: Woodward Avenue, 120 feet wide, adjoining Lot 29 “Plan of Section numbered Eight in the territory of Michigan confirmed unanimously by the Governor and Judges on the 27th day of April, 1807 and ordered to be a record and to be signed by the Governor and attested by the Secretary of the Board” as recorded in Liber 34, Page 543 of Deeds, Wayne County Records. Encroachments are further described as follows:

- 1) Steel canopy being 9.5 feet in height, 5.5 feet wide and 15.67 feet in length along Woodward Avenue lying east of the east line of said Lot 29. Canopy height must remain at a minimum of 8 feet above grade.

PROVIDED, that if there is any cost for the removing and/or rerouting of any utility facilities, it shall be done at the expense of the petitioner and/or property owner; and be it further

PROVIDED, that access is maintained to all fire department connections, and be it further

PROVIDED, that by approval of this petition the Detroit Water and Sewerage Department (DWSD) does not waive any of its rights to its facilities located in the right-of-way, and at all times, DWSD, its agents or employees, shall have the right to enter upon the right-of-way to maintain, repair, alter, service, inspect, or install its facilities. All costs incident to the damaging, dismantling, demolishing, removal and replacement of structures or other improvements herein permitted and incurred in gaining access to DWSD’s facilities for maintenance, repairing, alteration, servicing or inspection caused by the encroachment shall be borne by the petitioner. All costs associated with gaining access to DWSD’s facilities, which could normally be expected had the petitioner not encroached into the right-of-way, shall be borne by DWSD; and be it further

PROVIDED, that the petitioner maintain a vertical clearance of 18 feet above grade from DWSD facilities for maintenance access and repair; and be it further

PROVIDED, that all construction performed under this petition shall not be commenced until after (5) days written notice to DWSD. Seventy-two (72) hours’ notice shall also be provided in accordance with P.A. 53 1974, as amended, utilizing the MISS DIG one call system; and be it further

PROVIDED, that construction under this petition is subject to inspection and approval by DWSD forces. The cost of such inspection shall, at the discretion of DWSD, be borne by the petitioner; and be it further

PROVIDED, that if DWSD facilities located within the right-of-way shall break or be damaged as the result of any action on the part of the petitioner, then in such event the petitioner agrees to be liable for all costs incident to the repair, replacement or relocation of such broken or damaged DWSD facilities; and be it further

PROVIDED, that the underground pipes are encased in concrete to protect them from inadvertent damage, and permanent monuments be installed at the intersection of the property line and the centerline of the installed pipes, and further

PROVIDED, that the Keating Contracting, LLC or their assigns provide as-built drawings of their installation and the relationship to other utility infrastructure to the Department of Public Works – City Engineering Division, and further

PROVIDED, Keating Contracting, LLC or their assigns shall apply to the Buildings and Safety Engineering Department for a building permit prior to any construction. Also, if it becomes necessary to open cut public streets, bore, jack, occupy or barricade city rights-of-way for maintenance of encroachments such work shall be according to detail permit application drawings submitted to the City Engineering Division – DPW prior to any public right-of-way construction; and further

PROVIDED, that the necessary permits shall be obtained from the City Engineering Division – DPW and the Buildings and Safety Engineering Department. The encroachments shall be constructed and maintained under their rules and regulations; and further

PROVIDED, that all cost for the construction, maintenance, permits and use of the encroachments shall be borne by Keating Contracting, LLC or their assigns, and further

PROVIDED, that all costs incurred by privately owned utility companies and/or city departments to alter, adjust, and/or relocate their existing utility facilities located in close proximity to the encroachments shall be borne by Keating Contracting, LLC or their assigns. Should damages to utilities occur Keating Contracting, LLC or their assigns shall be liable for all incidental repair costs and waives all claims for damages to the encroaching installations; and further

PROVIDED, that no other rights in the public streets, alleys or other public place shall be considered waived by this permission which is granted expressly on the condition that said encroachments shall be removed at any time when so directed by the City Council, and the public property affected shall be restored to a condition satisfactory to the City Engineering Division – DPW; and further

PROVIDED, that Keating Contracting, LLC or their assigns shall file with the Department of Public Works – City Engineering Division an indemnity agreement in form approved by the Law Department. The agreement shall save and protect the City of Detroit from any and all claims, damages or expenses that may arise by reason of the issuance of the permits and the faithful or unfaithful performance of Keating Contracting, LLC or their assigns of the terms thereof. Further, Keating Contracting, LLC or their assigns shall agree to pay all claims, damages or expenses that may arise out of the use, repair and maintenance of the proposed encroachments; and further

PROVIDED, that filing of said indemnity agreement shall be construed as acceptance of this Resolution by the “permittee”; and further

PROVIDED, that all cost for the construction, maintenance, permits and use of the encroachments shall be borne by Downtown Detroit Partnership, or their assigns; and further

PROVIDED, that construction of the encroachments shall constitute acceptance of the terms and conditions as set forth in this resolution; and be it further

PROVIDED, this resolution or part thereof is revocable at the will, whim or caprice of the City Council, and Keating Contracting, LLC acquires no implied or other privileges hereunder not expressly stated herein; and further

PROVIDED, that the encroachment permits shall not be assigned or transferred without the written approval of the City Council; and be it further

PROVIDED, that the City Clerk shall within 30 days record a certified copy of this resolution with the Wayne County Register of Deeds.

PETITION NO. 1697
 KEATING CONTRACTING, LLC
 22775 HESLIP DR.
 NOVI, MICHIGAN 48375
 MARK KEATING
 PHONE NO. 248 730-9339

"REVISION-A"



CLIFFORD AVE. 60 FT. WD.

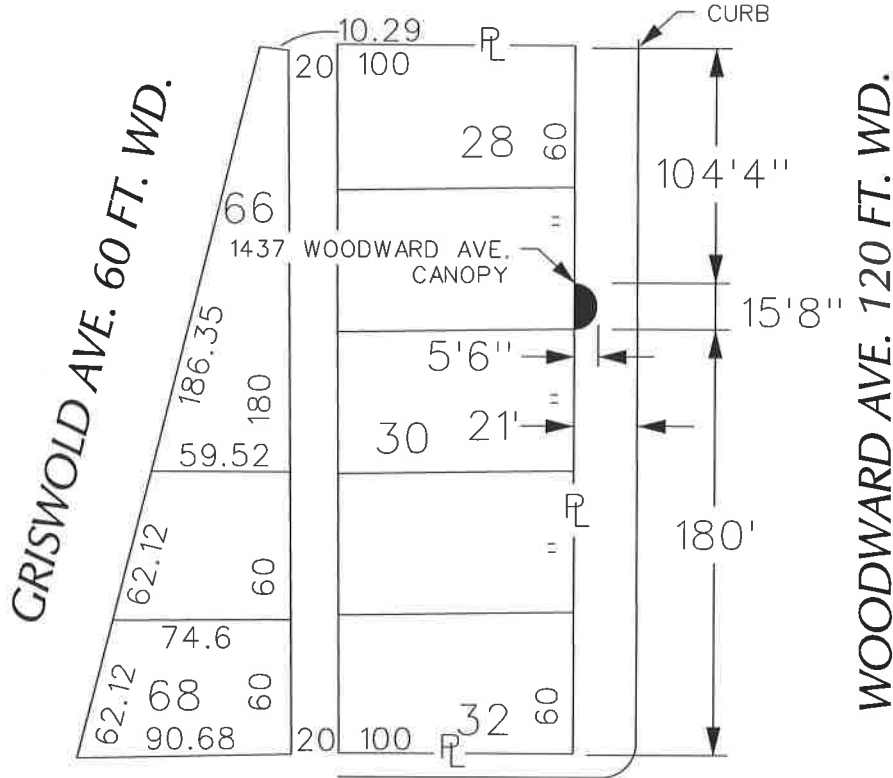

GD. RIVER AVE. 60 FT. WD.



 - REQUEST ENCROACHMENT
 (With Steel Canopies)

(FOR OFFICE USE ONLY)

CARTO 28 B

B				
A	SEPARATE THE DRAWING	SA	JD	01/03/20
REVISIONS				
DESCRIPTION	DRWN	CHKD	APPD	DATE
DRAWN BY	WLW	CHECKED	KSM	
DATE	05-09-19	APPROVED		

**REQUEST ENCROACHMENT
 INTO WOODWARD
 AT 1247 WOODWARD
 (With Steel Canopies)**

CITY OF DETROIT	
CITY ENGINEERING DIVISION	
SURVEY BUREAU	
JOB NO.	01-01
DRWG. NO.	X 1697