

TO: City Engineering Division, DPW
900 Cadillac Tower Building
65 Cadillac Square
Detroit, Michigan 48226-2873
Survey Bureau: 313-224-3970
Fax: 313-224-3471

Ref. No. 201704038
Petition No. 1446

The proposed change in property (referred to above) would affect our services as follows:

- () Not Involved.
- () Involved; but asking you to hold action on this petition until further notice.
- () Involved; the nature of our services, and the estimated costs of removing and/or rerouting such services are:
- (X) Involved; have no objection to the request encroachment into Griswold at 1214 Griswold (With Bike Rack) as shown on drawing no. x1446 dated 04/27/2017 provided that a minimum 6 ft wide clear, unobstructed sidewalk shall be maintained for pedestrian traffic in front of the encroachment area at all times.

Traffic Engineering Division - DPW
(Utility or City Department)

for
By Ashok Patel



City Traffic Engineer
Title

June 20, 2017
Date

313 224-1610
Area code-Telephone number

JL/jl

PETITION NO. 1446
 THE ALBERT IN CAPITOL PARK
 C/O BRODER & SACHSE REAL ESTATE SERVICES
 1214 GRISWOLD AVE.
 DETROIT, MICHIGAN 48226
 C/O MAX GORDON
 PHONE NO. 248 647-4100



GD. RIVER AVE. 60 FT. WD.

GRISWOLD AVE. 60 FT. WD.

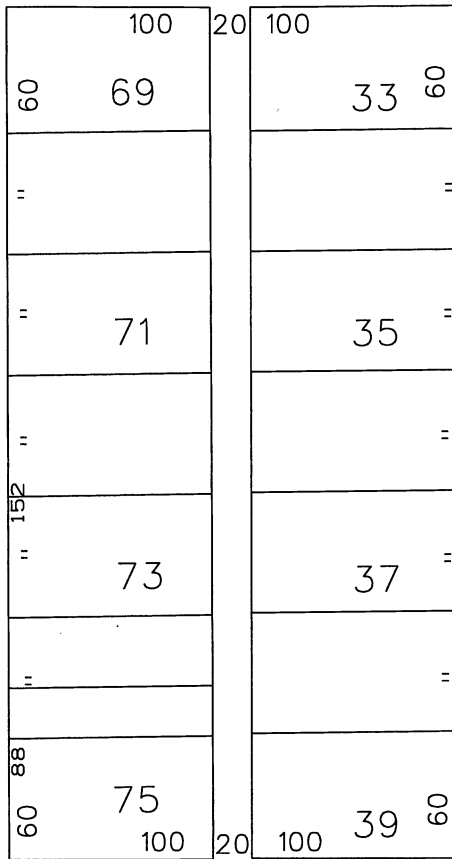

WOODWARD AVE. 100 FT. WD.

GRISWOLD AVE. 60 FT. WD.

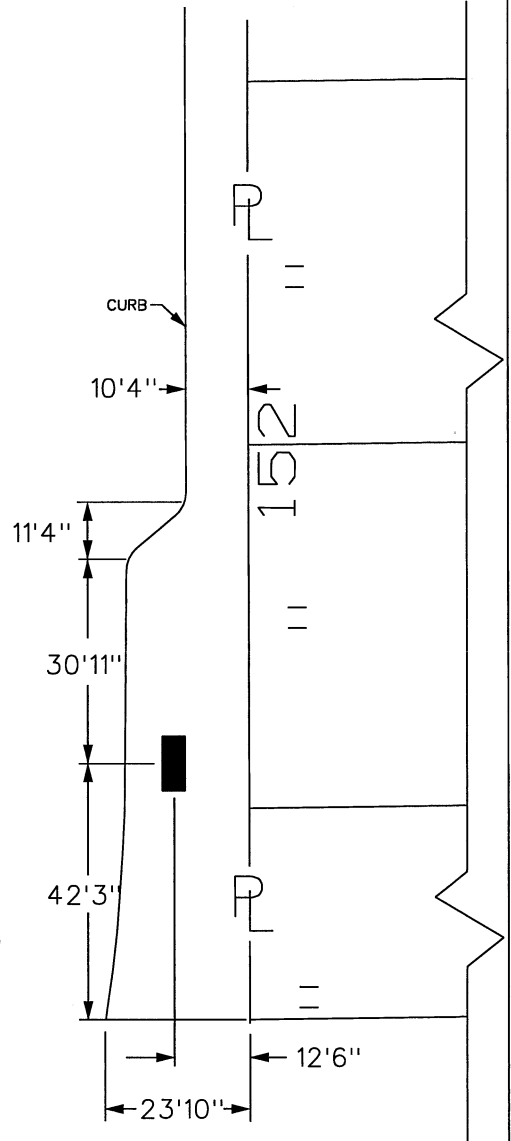

- REQUEST ENCROACHMENT
 (With Bike Rack)

(FOR OFFICE USE ONLY)

CARTO 28 B

B					
A					
DESCRIPTION		DRWN	CHKD	APPD	DATE
REVISIONS					
DRAWN BY	WLW	CHECKED			
DATE	04-27-17	APPROVED			

**REQUEST ENCROACHMENT
 INTO GRISWOLD
 AT 1214 GRISWOLD
 (With Bike Rack)**

CITY OF DETROIT	
CITY ENGINEERING DEPARTMENT	
SURVEY BUREAU	
JOB NO.	01-01
DRWG. NO.	X 1446