

**TO: City Engineering Division, DPW  
2 Woodward Ave., Suite 642  
Detroit, Michigan 48226-3462  
Survey Bureau: 313-224-3970**

**Petition: x1366**

The proposed change in property (referred to on the other side of this sheet) would affect our services as follows:

- Not Involved**  
Requesting encroachment for outdoor seating and planters for new restaurant.
- Involved; but asking you to hold action on this petition until further notice.**
- Involved; but no objections to the property change.**
- Involved; objection to the property change.**
- Involved; but no objections to the property change...provided as easement of the full width of the public right-of-way (street, alley or other public place) is reserved.**
- Involved; the nature of our services and the estimated costs of removing and/or rerouting such services are:**

Planning & Development Department

\_\_\_\_\_  
(Utility or City Department)

  
\_\_\_\_\_  
By

Greg Moots-Lead Planner-Office of Zoning Innovation

\_\_\_\_\_  
Title

April 3, 17  
\_\_\_\_\_  
Date

313-224-1358

\_\_\_\_\_  
Area code – Telephone number

City of Detroit  
**City Engineering Division, Department of Public Works  
Survey Bureau**

**NOTICE OF PROPOSED CHANGE IN PROPERTY**

Date: 03/28/2017

Petition: x1366

- |  |  |
|--|--|
| <input type="checkbox"/> AT&T Telecommunication            | <input type="checkbox"/> Berm Use                |
| <input type="checkbox"/> Comcast Television (CATV)         | <input type="checkbox"/> Conversion to Easement  |
| <input type="checkbox"/> Detroit Edison (DTE)              | <input type="checkbox"/> Dedication              |
| <input type="checkbox"/> Fire Department                   | <input checked="" type="checkbox"/> Encroachment |
| <input type="checkbox"/> Great Lakes Water Authority       | <input type="checkbox"/> Temporary Closing       |
| <input type="checkbox"/> Land Bank Authority               | <input type="checkbox"/> Vacation                |
| <input type="checkbox"/> Michcon (DTE)                     |  |
| <input type="checkbox"/> Planning & Development Department |  |
| <input type="checkbox"/> Public Lighting Authority         |  |
| <input type="checkbox"/> Public Lighting Department        |  |
| <input type="checkbox"/> Police Department                 |  |
| <input type="checkbox"/> Solid Waste Division, DPW         |  |
| <input type="checkbox"/> Street Design Bureau, DPW         |  |
| <input type="checkbox"/> Street Maintenance Division, DPW  |  |
| <input type="checkbox"/> Traffic Engineering Division, DPW |  |
| <input type="checkbox"/> Water and Sewerage Department     |  |
| <input type="checkbox"/> _____                             |  |

A petition drawing is attached. Property shown on the attached print is proposed to be changed as indicated. Kindly report (using the back of this sheet) the nature of your services, if any affected by the proposed change and the estimated costs of removing and rerouting such services (if necessary).

Please return one copy to City Engineering Division, DPW within two weeks of the submittal date. Retain one copy and print for you file.

Ron Brundidge, Director, Department of Public Works

By: Richard Doherty, CED DPW  
City Engineer

PETITION NO. 1366  
 SHAKE SHACK  
 660 WOODWARD AVE. SUITE 5A  
 DETROIT, MICHIGAN 48226  
 C/O TY JACKSON  
 PHONE NO. 646 747-3444

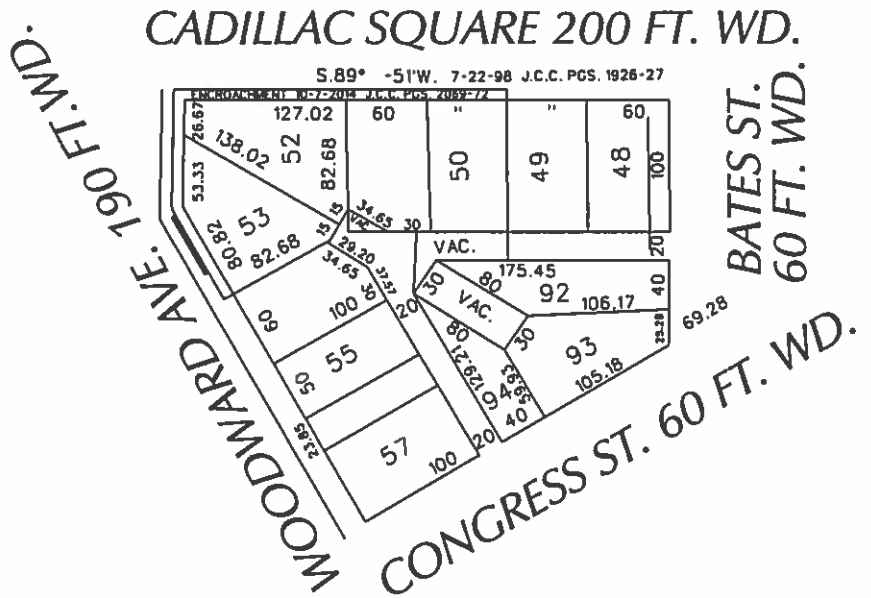
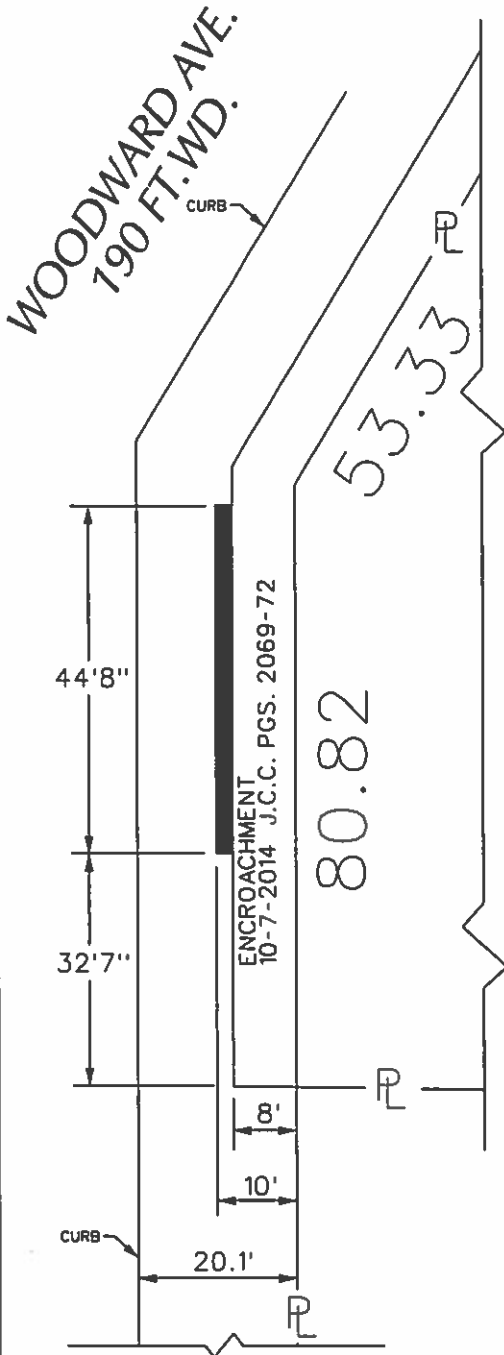

**■ - AREA OF ENCROACHMENT**  
 (With Outdoor Seating)

(FOR OFFICE USE ONLY)

CARTO 28 F

B					
A					
DESCRIPTION		DRWN	CHKD	APPD	DATE
REVISIONS					
DRAWN BY		CHECKED			
DATE		APPROVED			
03-28-17					

REQUEST ENCROACHMENT  
 INTO WOODWARD  
 AT 660 WOODWARD AVE.  
 (With Outdoor Cafe)

CITY OF DETROIT CITY ENGINEERING DEPARTMENT SURVEY BUREAU	
JOB NO.	01-01
DRWG. NO.	X 1366

