

TO: City Engineering Division, DPW
2 Woodward Ave., Suite 642
Detroit, MI 48226-3462
Survey Bureau: 313-224-3970

Ref. No. 201611018
Petition No. 1270

The proposed change in property (referred to above) would affect our services as follows:

- () Not Involved.
- () Involved; but asking you to hold action on this petition until further notice.
- () Involved; the nature of our services, and the estimated costs of removing and/or rerouting such services are:
- (X) Involved; have no objection to the requested encroachment into W. Lafayette at 615 W. Lafayette (with store front canopy, railing and café seating) as shown on drawing no. x1270 dated 9/22/2016 provided that the following conditions are met with:
 - (1) A minimum 5 ft wide clear sidewalk shall be maintained in front of the entire length of the outdoor seating area (including behind trunk of the proposed trees) at all times for pedestrian traffic.
 - (2) The tree grates shall be ADA compliant and shall be mounted flush with the sidewalk surface to prevent any tripping hazard to pedestrians.

Traffic Engineering Division - DPW
(Utility or City Department)

for Ashok Patel 
By

City Traffic Engineer
Title

November 29, 2016
Date

313 224-1610
Area code-Telephone number

MA/ma

PETITION NO. 1270
 GIFFELS WEBSTER
 28 W. ADAMS, SUITE 1200
 DETROIT, MICHIGAN 48226
 C/O DEIRDRE CLEIN
 PHONE NO. 313 962-4442

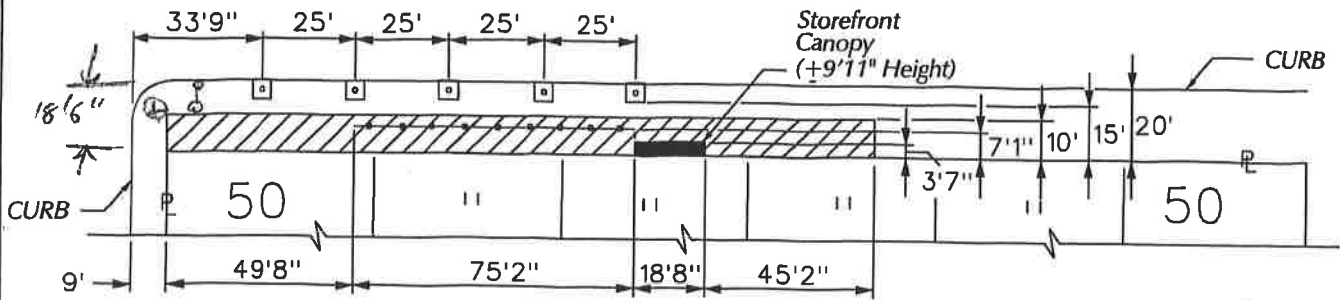

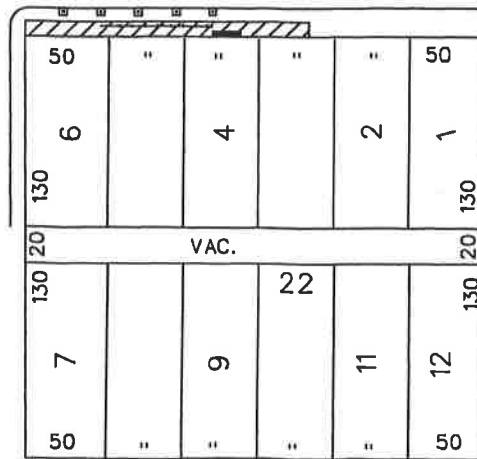

W. LAFAYETTE AVE. 80 FT. WD.

THIRD AVE. 60 FT. WD.



SECOND AVE. 60 FT. WD.

FORT ST. 100 FT. WD.

-  - REQUEST ENCROACHMENT (With Storefront Canopy)
-  - REQUEST ENCROACHMENT (With Railing)
-  - REQUEST ENCROACHMENT (With Cafe Seating)



(FOR OFFICE USE ONLY)

CARTO 28 E

B					
A					
	DESCRIPTION	DRWN	CHKD	APPD	DATE
	REVISIONS				
	DRAWN BY	CHECKED			
	DATE	APPROVED			
	09-22-16				

REQUEST ENCROACHMENT
 INTO W. LAFAYETTE
 AT 615 W. LAFAYETTE
 (With Storefront Canopy,
 Railing and Cafe Seating)

CITY OF DETROIT CITY ENGINEERING DEPARTMENT SURVEY BUREAU	
JOB NO.	01-01
DRWG. NO.	X 1270