



CITY OF DETROIT  
DEPARTMENT OF PUBLIC WORKS  
CITY ENGINEERING DIVISION

COLEMAN A. YOUNG MUNICIPAL CENTER  
2 WOODWARD AVENUE, SUITE 601  
DETROIT, MICHIGAN 48226  
PHONE: (313) 224-3949 • TTY: 711  
FAX: (313) 224-3471  
WWW.DETROITMI.GOV

January 18, 2017

Honorable City Council:

**RE: Petition No. 1270 – Giffels Webster request for encroachment into West Lafayette Boulevard right-of-way with canopies and café seating.**

Petition No. 1270 – Giffels Webster on behalf of Bedrock Real Estate Services request to install and maintain an encroachments with a canopy, grated trees and café seating on the south side of West Lafayette Avenue, 80 feet wide between Second Avenue, 60 feet wide and Third Avenue, 60 feet wide.

The petition was referred to the City Engineering Division – DPW for investigation and report. This is our report.

The request is being made to utilize the property as a commercial establishment, to promote street-level activity, and to provide for a future outdoor café at 615 West Lafayette Avenue.

Traffic Engineering Division – DPW (TED), reports being involved and approves provided certain conditions are met. The TED conditions have been made a part of the attached resolution.

Detroit Water and Sewerage Department (DWSD) being involved, but have no objection provided the DWSD encroachment provisions are followed. The DWSD provisions have been made a part of the resolution.

The Public Lighting Department report involvement with electric cable at 24,000 volts in conduit near the curb, but no objection provided care is exercised in excavating for tree plantings.

All other involved City Departments, including Public Lighting Authority and Great Lakes Water Authority (GLWA); also privately owned utility companies have reported no objections to the encroachment. Provisions protecting utility installations are part of the attached resolution.

I am recommending adoption of the attached resolution.

Respectfully submitted,

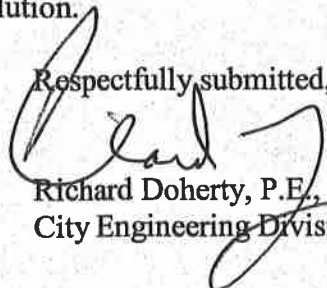

Richard Doherty, P.E., City Engineer  
City Engineering Division – DPW

JMK/

Cc: Ron Brundidge, Director, DPW  
Mayor's Office – City Council Liaison

BY COUNCIL MEMBER \_\_\_\_\_

**RESOLVED**, That the Department of Public Works, City Engineering Division is hereby authorized and directed to issue permits to Bedrock Real Estate Services to install and maintain an encroachment for a building canopy, grated sidewalk with trees and sidewalk café seating on the south side of West Lafayette Avenue, 80 feet wide between Second Avenue, 60 feet wide and Third Avenue, 60 feet wide. The canopy, and sidewalk café seating (including planters, barriers, and bike racks etcetera) shall extend no more than 10 feet into West Lafayette Avenue from the building frontage, the full length of the property. The canopy clearance shall be in compliance with the building code. The grated sidewalk with trees shall be installed between the curb and building lines. The encroachments may occupy the area from the sidewalk to the full height of the building adjoining the property described as: Land in the City of Detroit, Wayne County, Michigan, being all of Lots 4, 5 and 6 and the easterly 38.67 feet of Lot 3, Block 22 "Subdivision of the Cass Farm lying between Chicago Road and Fort Street" as recorded in Liber 12, Page 324 City Records, Wayne County Records.

**PROVIDED**, that if there is any cost for the removing and/or rerouting of any utility facilities, it shall be done at the expense of the petitioner and/or property owner; and be it further

**PROVIDED**, that the remaining sidewalk being a minimum of 5 feet wide from the encroachment to the curb be maintained free and clear from obstruction; and be it further

**PROVIDED**, that the tree grates are mounted flush to the sidewalk and are ADA compliant, also the trees planted shall have sufficient canopy clearance for pedestrian travel, and further

**PROVIDED**, By approval of this petition the Detroit Water and Sewerage Department (DWSD) does not waive any of its rights to its facilities located in the right-of-way, and at all times, DWSD, its agents or employees, shall have the right to enter upon the right-of-way to maintain, repair, alter, service, inspect, or install its facilities. All costs incident to the damaging, dismantling, demolishing, removal and replacement of structures or other improvements herein permitted and incurred in gaining access to DWSD's facilities for maintenance, repairing, alteration, servicing or inspection caused by the encroachment shall be borne by the petitioner. All costs associated with gaining access to DWSD's facilities, which could normally be expected had the petitioner not encroached into the right-of-way, shall be borne by DWSD; and be it further

**PROVIDED**, that all construction performed under this petition shall not be commenced until after (5) days written notice to DWSD. Seventy-two (72) hours notice shall also be provided in accordance with P.A. 53 1974, as amended, utilizing the MISS DIG one call system; and be it further

PROVIDED, that construction under this petition is subject to inspection and approval by DWSD forces. The cost of such inspection shall, at the discretion of DWSD, be borne by the petitioner; and be it further

PROVIDED, that if DWSD facilities located within the right-of-way shall break or be damaged as the result of any action on the part of the petitioner, then in such event the petitioner agrees to be liable for all costs incident to the repair, replacement or relocation of such broken or damaged DWSD facilities; and be it further

PROVIDED, that the petitioner shall hold DWSD harmless for any damages to the encroaching device constructed or installed under this petition which may be caused by the failure of DWSD's facilities; and be it further

PROVIDED, That if at any time in the future the petitioner shall request removal and/or relocation of DWSD's facilities in the right-of-way being encroached upon the petitioner agrees to pay all costs for such removal and/or relocation; and be it further

PROVIDED, that the contractor call MISS DIG 72 hours prior to starting any underground construction where they plan the underground encroachment including tree planting; and be it further

PROVIDED, that Bedrock Real Estate Services or their assigns shall apply to the Buildings and Safety Engineering Department for a building permit prior to any construction. Also, if it becomes necessary to open cut public streets, bore, jack, occupy or barricade city rights-of-way for maintenance of encroachments such work shall be according to detail permit application drawings submitted to the City Engineering Division – DPW prior to any public right-of-way construction; and further

PROVIDED, that the necessary permits shall be obtained from the City Engineering Division – DPW and the Buildings and Safety Engineering Department. The encroachments shall be constructed and maintained under their rules and regulations; also in accord with plans submitted to and approved by these departments, including the Public Lighting Department (if necessary), and the Traffic Engineering Division – DPW (if necessary); and further

PROVIDED, that the area being used as an Outdoor Café shall meet the general requirements set by the “Outdoor Café Guidelines” as adopted by the City Council and guided by Section 50-2-8.1 of the City Code; and further

PROVIDED, that the petitioner obtains all necessary licenses and permits every year from Departments having jurisdiction over the outdoor café process; and further

PROVIDED, that said activities are conducted under the rules and regulations of the Department of Public Works and the supervision of the Police Department; and further

PROVIDED, that the sale of food or soft drinks is held under the direction and inspection of the Institute of Population Health; and further

PROVIDED, that the petitioner is responsible to obtain approval of the Michigan Liquor Control Commission, if necessary and approval from the Detroit Police Liquor License Bureau if serving liquor; and further

PROVIDED, that all cost for the construction, maintenance, permits and use of the encroachments shall be borne by Bedrock Real Estate Services or their assigns; and further

PROVIDED, that all costs incurred by privately owned utility companies and/or city departments to alter, adjust, and/or relocate their existing utility facilities located in close proximity to the encroachments shall be borne by Bedrock Real Estate Services or their assigns. Should damages to utilities occur Bedrock Real Estate Services shall be liable for all incidental repair costs and waives all claims for damages to the encroaching installations; and further

PROVIDED, that no other rights in the public streets, alleys or other public place shall be considered waived by this permission which is granted expressly on the condition that said encroachments shall be removed at any time when so directed by the City Council, and the public property affected shall be restored to a condition satisfactory to the City Engineering Division – DPW; and further

PROVIDED, this resolution is revocable at the will, whim or caprice of the City Council, and Bedrock Real Estate Services acquires no implied or other privileges hereunder not expressly stated herein; and further

PROVIDED, that the encroachment permits shall not be assigned or transferred without the written approval of the City Council; and further

PROVIDED, that the City Clerk shall within 30 days record a certified copy of this resolution with the Wayne County Register of Deeds.

PETITION NO. 1270  
 GIFFELS WEBSTER  
 28 W. ADAMS, SUITE 1200  
 DETROIT, MICHIGAN 48226  
 C/O DEIRDRE CLEIN  
 PHONE NO. 313 962-4442

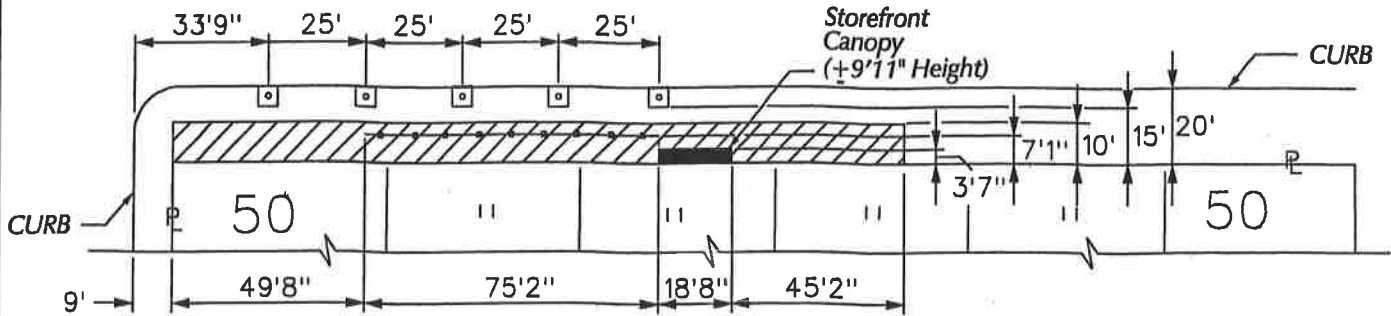

W. LAFAYETTE AVE. 80 FT. WD.

THIRD AVE. 60 FT. WD.

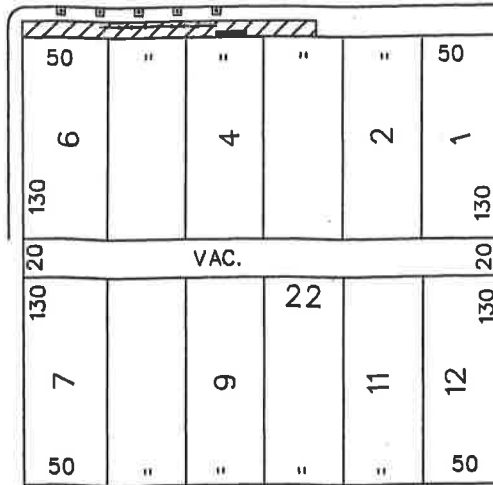

SECOND AVE. 60 FT. WD.

FORT ST. 100 FT. WD.

 - REQUEST ENCROACHMENT  
 (With Storefront Canopy)

 - REQUEST ENCROACHMENT  
 (With Railing)

 - REQUEST ENCROACHMENT  
 (With Cafe Seating)

 Tree Grate

(FOR OFFICE USE ONLY)

CARTO 28 E

B					
A					
DESCRIPTION	DRWN	CHKD	APPD	DATE	
REVISIONS					
DRAWN BY	WLW	CHECKED			
DATE	09-22-16	APPROVED			

REQUEST ENCROACHMENT  
 INTO W. LAFAYETTE  
 AT 615 W. LAFAYETTE  
 (With Storefront Canopy,  
 Railing and Cafe Seating)

CITY OF DETROIT  
 CITY ENGINEERING DEPARTMENT  
 SURVEY BUREAU

JOB NO. 01-01

DRWG. NO. X 1270