



CITY OF DETROIT
DEPARTMENT OF PUBLIC WORKS
CITY ENGINEERING DIVISION

COLEMAN A. YOUNG MUNICIPAL CENTER
2 WOODWARD AVENUE, SUITE 601
DETROIT, MICHIGAN 48226
PHONE: (313) 224-3949 • TTY: 711
FAX: (313) 224-3471
WWW.DETROITMI.GOV

January 20, 2016

Honorable City Council:

RE: Petition No. 777, Thair Zaitouna, request permission to encroach into Harper Avenue right-of-way sidewalk with proposed masonry for the property located at 8330 Harper Avenue, Detroit, MI 48213.

Petition No. 777 – Thair Zaitouna requests to install and maintain an encroachment consisting of a new masonry facade on Harper Avenue, 86 feet wide, between Seminole Avenue, 60 feet wide and Iroquois Avenue, 60 feet wide.

The petition was referred to the City Engineering Division – DPW for investigation and report. This is our report.

The request is being made as part of the renovation of and improvement of the Kit Kat Market.

Traffic Engineering Division – DPW (TED), reports being involved and approves provided certain conditions are met. The TED conditions have been made a part of the attached resolution.

Public Lighting Department (PLD) reports that there is an overhead street lighting wire in front of the building; but they have no objection.

Detroit Water and Sewerage Department (DWSD) reports being involved, but has no objection provided the DWSD encroachment provisions are followed. The DWSD provisions have been made a part of the resolution.

DTE Energy – Gas Division reports involvement and their remarks have been made a part of the resolution. All other involved City Departments, including the Public Lighting Authority; also privately owned utility companies have reported no objections to the encroachment. Provisions protecting utility installations are part of the attached resolution.

I am recommending adoption of the attached resolution.

Respectfully submitted,

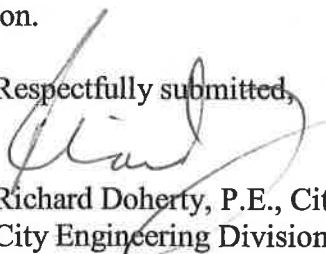
Richard Doherty, P.E., City Engineer
City Engineering Division – DPW

JMK/

Cc: Ron Brundidge, Director, DPW
Mayor's Office – City Council Liaison

BY COUNCIL MEMBER _____

RESOLVED, That the Department of Public Works, City Engineering Division is hereby authorized and directed to issue permits to Thair Zaitouna and/or his assigns to install and maintain an encroachment consisting of a new masonry facade on Harper Avenue, 86 feet wide, between Seminole Avenue, 60 feet wide and Iroquois Avenue, 60 feet wide. The encroachment will be adjoining land in the City of Detroit, Wayne County, Michigan being Lot 18, Block 2 except Harper Avenue as widened "Stephen's Elm Park Subdivision of all that part of Private Claims 180, 153 & 155 lying North of Gratiot Avenue, City of Detroit, Wayne County, Mich." as recorded in Liber 19, Page 12 of Plats, Wayne County Records. The encroachment will be 100 feet in length and 4 inches in width; and the location described as: beginning 7 feet east of the west line of the above described parcel of land and extending easterly to 3 feet west of the east line of the above described parcel of land.

PROVIDED, that if there is any cost for the removing and/or rerouting of any utility facilities, it shall be done at the expense of the petitioner and/or property owner; and be it further

PROVIDED, By approval of this petition the Detroit Water and Sewerage Department (DWSD) does not waive any of its rights to its facilities located in the right-of-way, and at all times, DWSD, its agents or employees, shall have the right to enter upon the right-of-way to maintain, repair, alter, service, inspect, or install its facilities. All costs incident to the damaging, dismantling, demolishing, removal and replacement of structures or other improvements herein permitted and incurred in gaining access to DWSD's facilities for maintenance, repairing, alteration, servicing or inspection caused by the encroachment shall be borne by the petitioner. All costs associated with gaining access to DWSD's facilities, which could normally be expected had the petitioner not encroached into the right-of-way, shall be borne by DWSD; and be it further

PROVIDED, that all construction performed under this petition shall not be commenced until after (5) days written notice to DWSD. Seventy-two (72) hours notice shall also be provided in accordance with P.A. 53 1974, as amended, utilizing the MISS DIG one call system; and be it further

PROVIDED, that construction under this petition is subject to inspection and approval by DWSD forces. The cost of such inspection shall, at the discretion of DWSD, be borne by the petitioner; and be it further

PROVIDED, that if DWSD facilities located within the right-of-way shall break or be damaged as the result of any action on the part of the petitioner, then in such event the petitioner agrees to be liable for all costs incident to the repair, replacement or relocation of such broken or damaged DWSD facilities; and be it further

PROVIDED, that the petitioner shall hold DWSD harmless for any damages to the encroaching device constructed or installed under this petition which may be caused by the failure of DWSD's facilities; and be it further

PROVIDED, That if at any time in the future the petitioner shall request removal and/or relocation of DWSD's facilities in the right-of-way being encroached upon the petitioner agrees to pay all costs for such removal and/or relocation; and be it further

PROVIDED, that the contractor call MISS DIG 72 hours prior to starting any underground construction for the encroachment; and be it further

PROVIDED, that a minimum 6 foot wide clear sidewalk shall be maintained adjacent to the encroachment at all times for pedestrian traffic; and be it further

PROVIDED, that DTE – Gas division reports involvement. The nature of their services, and the estimated costs of removing and/or relocating/rerouting, including the following: Field investigation, Survey, Design and drawing of the gas utilities will be determined by Michcon Gas Company's Public Improvement Department. Please contact the following persons at 313-389-7211 (Michael Fedele – Supervisor and/or (Laura Forrester – Gas Planner) at 313-389-7261; and be it further

PROVIDED, that the necessary permits shall be obtained from the City Engineering Division – DPW and the Buildings and Safety Engineering Department. The encroachments shall be constructed and maintained under their rules and regulations; also in accord with plans submitted to and approved by these departments, including the Public Lighting Department (if necessary), and the Traffic Engineering Division – DPW (if necessary); and further

PROVIDED, that all cost for the construction, maintenance, permits and use of the encroachments shall be borne by Thair Zaitouna and/or his assigns; and further

PROVIDED, that all costs incurred by privately owned utility companies and/or city departments to alter, adjust, and/or relocate their existing utility facilities located in close proximity to the encroachments shall be borne by Thair Zaitouna and/or his assigns. Should damages to utilities Thair Zaitouna. and/or his assigns shall be liable for all incidental repair costs and waives all claims for damages to the encroaching installations; and further

PROVIDED, that no other rights in the public streets, alleys or other public place shall be considered waived by this permission which is granted expressly on the condition that said encroachments shall be removed at any time when so directed by the City Council, and the public property affected shall be restored to a condition satisfactory to the City Engineering Division – DPW; and further

PROVIDED, That Thair Zaitouna shall file with the Finance Department and/or City Engineering Division – DPW an indemnity agreement in a form approved by the Law Department. The agreement shall save and protect the City of Detroit from any and all claims, damages or expenses that may arise by reason of the issuance of the permits and the faithful or unfaithful performance

by Thair Zaitouna of the terms thereof. Further, Thair Zaitouna shall agree to pay all claims, damages or expenses that may arise out of the maintenance of the proposed encroachments; and further

PROVIDED, this resolution is revocable at the will, whim or caprice of the City Council, and Thair Zaitouna acquires no implied or other privileges hereunder not expressly stated herein; and further

PROVIDED, that the encroachment permits shall not be assigned or transferred without the written approval of the City Council; and further

PROVIDED, that the City Clerk shall within 30 days record a certified copy of this resolution with the Wayne County Register of Deeds.

PETITION NO. 777
 THAIR ZAITOUNA
 C/O KIT KAT MARKET
 8330 HARPER AVE.
 DETROIT, MICHIGAN 48213
 C/O JACOB ZAITOUNA
 PHONE NO. 248 884-5299



HARPER AVE. 86 FT. WD.

SEMINOLE AVE. 60 FT. WD.

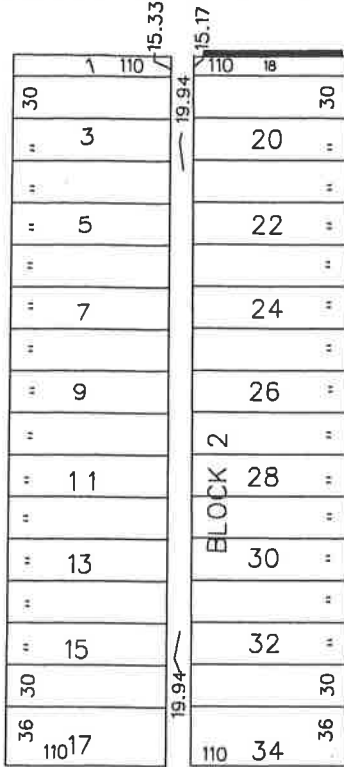

IROQUOIS AVE. 60 FT. WD.

HARPER AVE. 86 FT. WD.

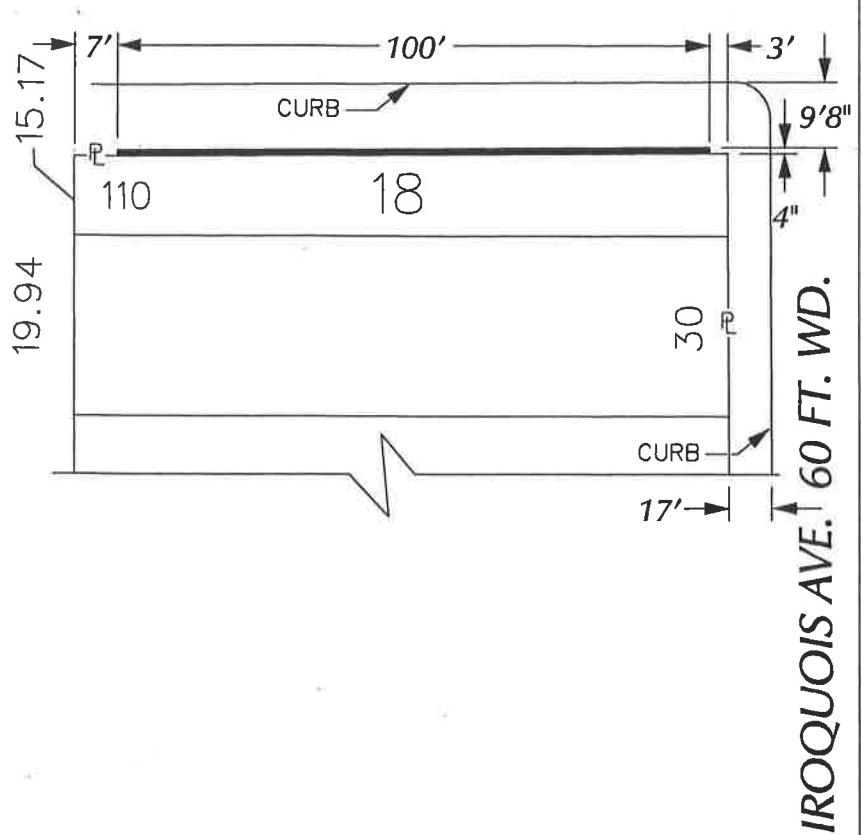

EDSEL FORD EXWY.

 - REQUEST ENCROACHMENT
 (With Masonry Building Facade)

(FOR OFFICE USE ONLY)

CARTO 49 F

B						REQUEST ENCROACHMENT INTO HARPER AT 8330 HARPER AVE. (With Masonry Building Facade)	CITY OF DETROIT CITY ENGINEERING DEPARTMENT SURVEY BUREAU	
A								JOB NO. 01-01
DESCRIPTION		DRWN	CHKD	APPD	DATE			DRWG. NO. X 777
REVISIONS								
DRAWN BY WLW		CHECKED						
DATE 09-09-15		APPROVED						