

City of Detroit
City Engineering Division, Department of Public Works
Survey Bureau

NOTICE OF PROPOSED CHANGE IN PROPERTY

2nd Notice 8/14/15

Date: 06/24/2015

Petition: x709

- | | |
|---|--|
| <input type="checkbox"/> AT&T Telecommunication | |
| <input type="checkbox"/> Cable Television (CATV) | <input type="checkbox"/> Vacation |
| <input type="checkbox"/> Detroit Edison (DTE) | |
| <input type="checkbox"/> Michigan Consolidated Gas (DTE) | <input type="checkbox"/> Conversion to Easement |
| <input type="checkbox"/> Fire Department | <input type="checkbox"/> Dedication |
| <input type="checkbox"/> Planning & Development Department | |
| <input type="checkbox"/> Public Lighting Authority | <input checked="" type="checkbox"/> Encroachment |
| <input type="checkbox"/> Public Lighting Dept. - Communication Division | |
| <input type="checkbox"/> Public Lighting Dept. - Overhead Line Division | |
| <input type="checkbox"/> Public Lighting Dept. - Underground Division | <input type="checkbox"/> Temporary Closing |
| <input type="checkbox"/> Police Department | |
| <input type="checkbox"/> Recreation Department | <input type="checkbox"/> Berm Use |
| <input type="checkbox"/> Sanitation Division, DPW | |
| <input type="checkbox"/> Street Design Bureau, DPW | |
| <input checked="" type="checkbox"/> Street Maintenance Division, DPW | |
| <input type="checkbox"/> Street and Traffic Division, DPW | |
| <input type="checkbox"/> Water and Sewerage Dept. - Sewer Design | |
| <input type="checkbox"/> Water and Sewerage Dept. - Water Design | |

A petition drawing is attached. Property shown on the attached print is proposed to be changed as indicated.

Kindly report (using the back of this sheet) the nature of your services If any) affected by the proposed change and the estimated costs of removing and rerouting such services (if necessary).

Please return one copy to City Engineering Division, DPW. Retain one copy and print for you file.

Ron Brundidge, Director, Department of Public Works

By: Richard Doherty, CED DPW
City Engineer

**TO: City Engineering Division, DPW
65 Cadillac Square, Suite 900
Detroit, Michigan 48226-2873
Survey Bureau: 313-224-3970**

x709

The proposed change in property (referred to on the other side of this sheet) would affect our services as follows:

- Not Involved
- Involved; but asking you to hold action on this petition until further notice.
- Involved; but no objections to the property change.
- Involved; but no objections to the property change...provided as easement of the full width of the public right-of-way (street, alley or other public place) is reserved.
- Involved; the nature of our services and the estimated costs of removing and/or rerouting such services are:

DPW / Street Maintenance Division

(Utility or City Department)

Dhaval Patel

By

Supervisor

Title

8/27/2015

Date

313-224-0021

Area code – Telephone number

PETITION NO. 709
 REPUBLIC TAVERN & NEW GAR, LLC
 1942 GRAND RIVER AVE.
 DETROIT, MICHIGAN 48226
 C/O TOM CARLETON
 PHONE NO. 313 674-0280



ADAMS AVE. 60 FT. WD.

85.64

REPUBLIC TAVERN & NEW GAR

8.28
 8.11

GD. RIVER AVE. 100 FT. WD.
 N. OF GD. RIVER
 FARM N. OF CASS
 SUBN. OF CASS FARM N. OF GD. RIVER

CURB

CASS AVE. 71 FT. WD.

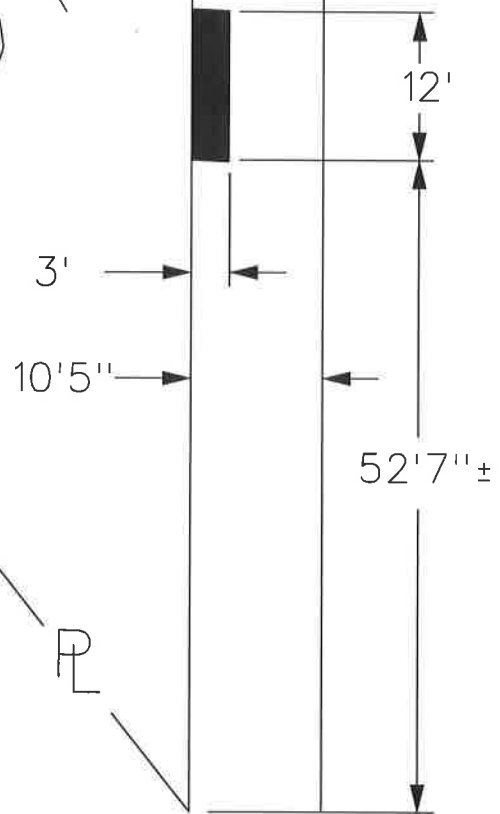

- REQUEST ENCROACHMENT
 (With Garbage Bin/Flower Planter)

(FOR OFFICE USE ONLY)

CARTO 28 B

B					
A					
DESCRIPTION	DRWN	CHKD	APPD	DATE	
REVISIONS					
DRAWN BY	WLW	CHECKED			
DATE	06-24-15	APPROVED			

REQUEST ENCROACHMENT
 (With Garbage Bin/Flower Planter)
INTO CASS
AT 1942 GRAND RIVER

CITY OF DETROIT
 CITY ENGINEERING DEPARTMENT
 SURVEY BUREAU

JOB NO. 01-01
 DRWG. NO. X 709

G.A.R. BUILDING Garbage Bin / Planter CASS AVE.

ADAMS AVE
(60 FT. WD.)

TRAFFIC SIGNAL
MAST POLE

CONCRETE SAWCUT CONTROL
JOINTS AT 2'-0" O.C. TYPICAL IN
EACH DIRECTION THIS AREA

ADAMS STREET SIDEWALK
AREA - 1,152 SF

EXISTING ADA TRANSITION TO
REMAIN - TYPICAL

EXISTING CONCRETE CURB TO
REMAIN, REPAIR AREAS WHERE
CURB HAS BEEN DAMAGED
MECHANICAL AREAWAY W/ STEEL
GRATING FLUSH W/ SIDEWALK SEE
SHEET AS 37 FOR DETAILS

CONCRETE SAWCUT CONTROL
JOINTS AT 5'-0" O.C. TYPICAL IN
EACH DIRECTION

4" CONCRETE PAVING ON 4"
COMPACTED GRAVEL BASE - TYPICAL
AT ALL NEW SIDEWALK AREAS

EXISTING CL
BASEMENT

2 X 2 X 1/4"

BUILDING FF

1' X 2' STEEL

AREAWAY C

8" WIDE CON

AROUND (3)

AREAWAY, F

CAST INTO C

SUPPORT STI

CONCRETE

COMPACTED

EXISTING ST

FOUNDATIO

AREAWAY

4" CONCRET

COMPACTEE

FLOOR OF A

NEW FLOOR

INTEGRATED

CONCRETE

EXISTING FC

FOR AREAW

**GRAND ARMY OF THE
REPUBLIC BUILDING**
1942 GRAND RIVER
AVENUE
TAX ID: 02000361
0.115 ACRES

CASS AVENUE SIDEWALK AREA - 1,436 SF

CASS AVE
(71 FT. WD.)

MAIN BUILDING ENTRANCE
ELEVATION 100'-0"

CONCRETE SAWCUT CONTROL
JOINTS AT 2'-0" O.C. TYPICAL IN
EACH DIRECTION THIS AREA

GRAND RIVER AVENUE SIDEWALK
AREA - 2,158 SF

GRAND RIVER AVE
(100 FT. WD.)

DRAIN AT BOTTOM OF
AREAWAY

6" WIDE CONCRETE CURB
FLUSH W/ SIDEWALK
ELEVATION AROUND
PERIMETER OF AREAWAY

MECHANICAL DUCT SEE
MECHANICAL DRAWINGS

DINER ENTRANCE
ELEVATION 100'-0"

TRAFFIC SIGNAL
MAST POLE

EXISTING ADA ACCESSIBLE CURB

