

NPB15-040
#6

City of Detroit
City Engineering Division, Department of Public Works
Survey Bureau

NOTICE OF PROPOSED CHANGE IN PROPERTY

Date: 02/18/2015

Petition: x402

- AT&T Telecommunication
- Cable Television (CATV)
- Detroit Edison (DTE)
- Michigan Consolidated Gas (DTE)
- Fire Department
- Planning & Development Department
- Public Lighting Authority
- Public Lighting Dept. - Communication Division
- Public Lighting Dept. - Overhead Line Division
- Public Lighting Dept. - Underground Division
- Police Department
- Recreation Department
- Sanitation Division, DPW
- Street Design Bureau, DPW
- Street Maintenance Division, DPW
- Street and Traffic Division, DPW
- Water and Sewerage Dept. - Sewer Design
- Water and Sewerage Dept. - Water Design
- Vacation
- Conversion to Easement
- Dedication
- Encroachment
- Temporary Closing
- Berm Use

A petition drawing is attached. Property shown on the attached print is proposed to be changed as indicated.

Kindly report (using the back of this sheet) the nature of your services if any) affected by the proposed change and the estimated costs of removing and rerouting such services (if necessary).

Please return one copy to City Engineering Division, DPW. Retain one copy and print for you file.

Ron Brundidge, Director, Department of Public Works

By: Richard Doherty, CED DPW
City Engineer

TO: City Engineering Division, DPW
65 Cadillac Square, Suite 900
Detroit, Michigan 48226-2873
Survey Bureau: 313-224-3970

x402

The proposed change in property (referred to on the other side of this sheet) would affect our services as follows:

- Not Involved
- Involved; but asking you to hold action on this petition until further notice.
- Involved; but no objections to the property change.
- Involved; but no objections to the property change...provided as easement of the full width of the public right-of-way (street, alley or other public place) is reserved.
- Involved; the nature of our services and the estimated costs of removing and/or rerouting such services are:

POLICE DEPARTMENT 11450 WARWICK
(Utility or City Department)

JOSEPH MACHON
By

SERGEANT, S-365
Title

APRIL 8, 2015
Date

(313) 596-5610
Area code - Telephone number

PETITION NO. 402
 MIKE BABY
 19300 SCHOOLCRAFT AVE.
 DETROIT, MICHIGAN 48223
 C/O MIKE BABY
 PHONE NO. 248 895-7264

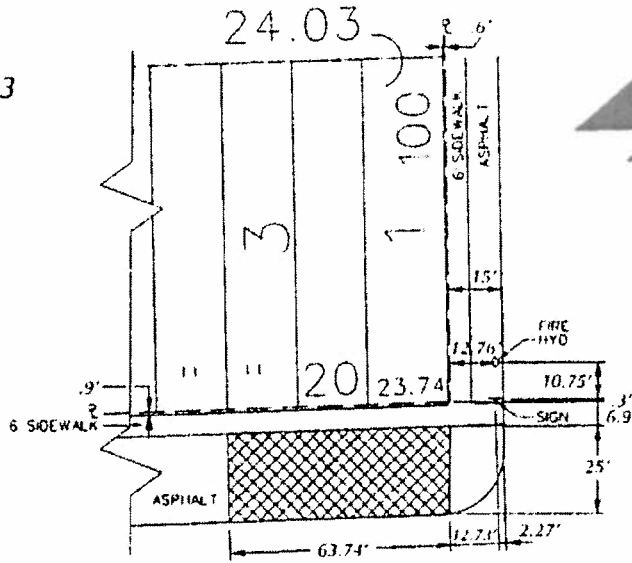

GRANDVILLE AVE. 70 FT. WD.

SCHOOLCRAFT AVE. 96 FT. WD.

KENDALL AVE. 60 FT. WD.

WESTWOOD AVE. 60 FT. WD.

GRANDVILLE AVE. 70 FT. WD.

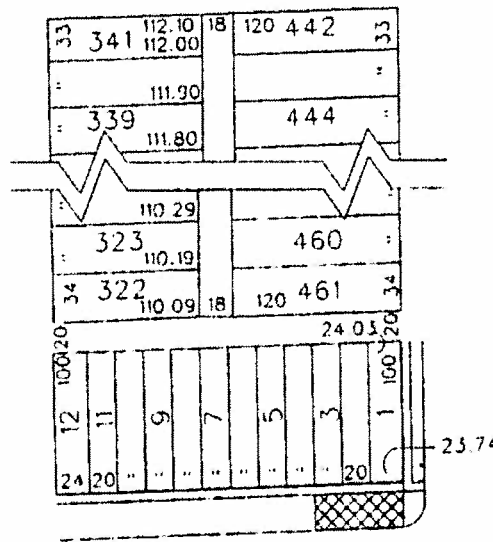

SCHOOLCRAFT AVE. 96 FT. WD.



- REQUESTED BERM USE
 (For Parking Only)

(FOR OFFICE USE ONLY)

CARTO 112 F

B					
A					
	DESCRIPTION	REVISED	CHKD	APPD	DATE
	REVISIONS				
	DRAWN BY	CHECKED			
	DATE	APPROVED			
	02-18-15				

REQUEST BERM USE
 (For Parking Only)
 INTO SCHOOLCRAFT AVE.
 AT 19300 SCHOOLCRAFT AVE.

CITY OF DETROIT
 CITY ENGINEERING DEPARTMENT
 SURVY BUREAU
 JOB NO. 01-01
 DRWG. NO. X 402