



City of Detroit
Inter-Departmental Communication

TO: Richard Doherty, City Engineer
City Engineering/Department of Public Works

FROM: Debra Singleton, Manager II
Detroit Water and Sewerage Department

DATE: January 8, 2015

RE: Petition No 419
Requested Encroachment into the North Side of Agnes Ave. between Van Dyke
and Parker Ave. (with Bike Racks)

DWSD has reviewed the above Petition received by this office on November 4, 2014. With regard to DWSD's interests, our comment is as follows:

- Our records indicate that there is a sewer in Agnes. DWSD has no objection to the requested encroachment provided that the attached Provisions for Encroachment are strictly followed.

If you have any questions, please call me at (313) 267-8309.

Sincerely,

A handwritten signature in black ink that reads "D. Singleton".

Debra Singleton
Manager II
Claims and Permits

DS//gl

Attachments

CC: Cheryl Porter, WBB
Mohamad Farhat, CSF

Michael Duggan, Mayor

City of Detroit
City Engineering Division, Department of Public Works
Survey Bureau

NOTICE OF PROPOSED CHANGE IN PROPERTY

Date: 11/03/2014

Petition: x419

- | | |
|---|--|
| <input type="checkbox"/> AT&T Telecommunication | |
| <input type="checkbox"/> Cable Television (CATV) | <input type="checkbox"/> Vacation |
| <input type="checkbox"/> Detroit Edison (DTE) | |
| <input type="checkbox"/> Michigan Consolidated Gas (DTE) | <input type="checkbox"/> Conversion to Easement |
| <input type="checkbox"/> Fire Department | <input type="checkbox"/> Dedication |
| <input type="checkbox"/> Planning & Development Department | |
| <input type="checkbox"/> Public Lighting Authority | <input checked="" type="checkbox"/> Encroachment |
| <input type="checkbox"/> Public Lighting Dept. - Communication Division | |
| <input type="checkbox"/> Public Lighting Dept. - Overhead Line Division | |
| <input type="checkbox"/> Public Lighting Dept. - Underground Division | <input type="checkbox"/> Temporary Closing |
| <input type="checkbox"/> Police Department | |
| <input type="checkbox"/> Recreation Department | <input type="checkbox"/> Berm Use |
| <input type="checkbox"/> Sanitation Division, DPW | |
| <input type="checkbox"/> Street Design Bureau, DPW | |
| <input type="checkbox"/> Street Maintenance Division, DPW | |
| <input type="checkbox"/> Street and Traffic Division, DPW | |
| <input type="checkbox"/> Water and Sewerage Dept. - Sewer Design | |
| <input type="checkbox"/> Water and Sewerage Dept. - Water Design | |

A petition drawing is attached. Property shown on the attached print is proposed to be changed as indicated.

Kindly report (using the back of this sheet) the nature of your services (if any) affected by the proposed change and the estimated costs of removing and rerouting such services (if necessary).

Please return one copy to City Engineering Division, DPW. Retain one copy and print for you file.

Ron Brundidge, Director, Department of Public Works

By: Richard Doherty, CED DPW
City Engineer

**TO: City Engineering Division, DPW
65 Cadillac Square, Suite 900
Detroit, Michigan 48226-2873
Survey Bureau: 313-224-3970**

The proposed change in property (referred to on the other side of this sheet) would affect our services as follows:

- Not Involved
- Involved; but asking you to hold action on this petition until further notice.
- Involved; but no objections to the property change.
- Involved; but no objections to the property change...provided as easement of the full width of the public right-of-way (street, alley or other public place) is reserved.
- Involved; the nature of our services and the estimated costs of removing and/or rerouting such services are:

(Utility or City Department)

By

Title

Date

Area code – Telephone number

PETITION NO. 419
 INTERSECTION CONSULTING GROUP
 8120 E. JEFFERSON AVE.
 DETROIT, MICHIGAN 48214
 C/O BRIAN R. ELLISON
 PHONE NO. 313 397-5863

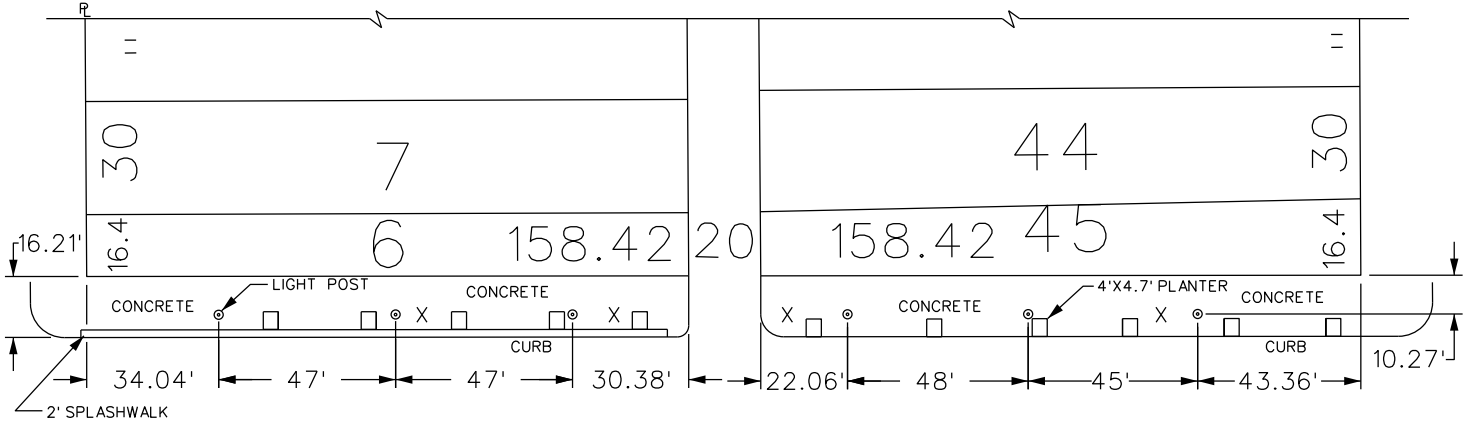

VAN DYKE AVE. 66 FT. WD.

COE AVE. 60 FT. WD.

PARKER ST. 60 FT. WD.

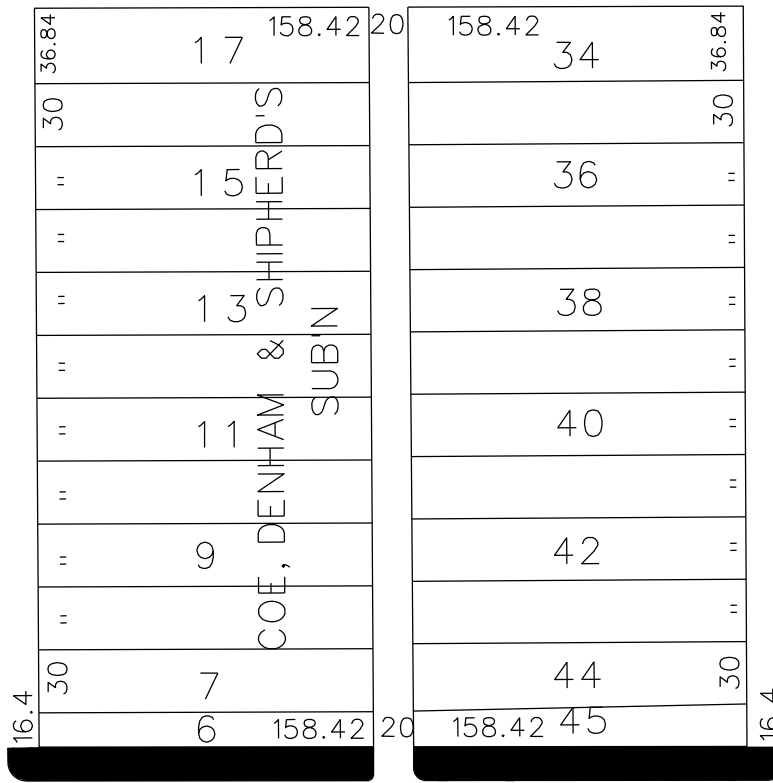

AGNES ST. 60 FT. WD.

LEGEND:

- X Proposed Bike Rack
- 4'x4.7' Planters
- ⊙ Light pole

- REQUEST ENCROACHMENT
 (With Bike Racks)

(FOR OFFICE USE ONLY)

CARTO 46 B

B					
A					
DESCRIPTION		DRWN	CHKD	APPD	DATE
REVISIONS					
DRAWN BY	WLW	CHECKED			
DATE	11-03-14	APPROVED			

REQUEST ENCROACHMENT
 INTO THE NORTH SIDE OF AGNES AVE.
 BETWEEN VAN DYKE AND PARKER AVE.
 (With Bike Racks)

CITY OF DETROIT
 CITY ENGINEERING DEPARTMENT
 SURVEY BUREAU

JOB NO. 01-01

DRWG. NO. X 419

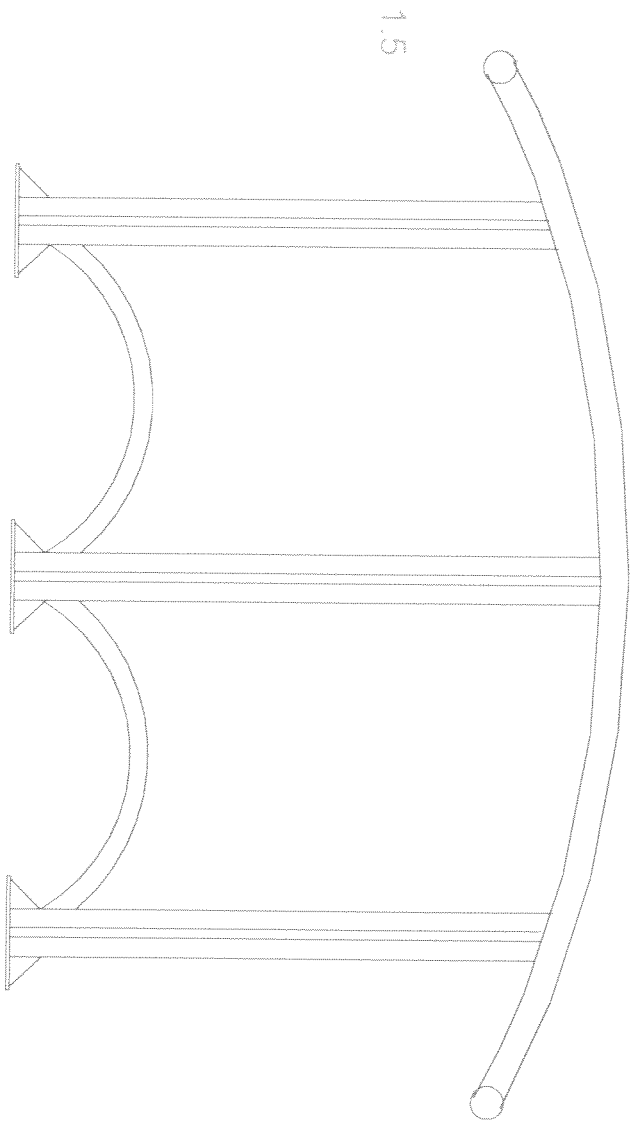

54

1.5

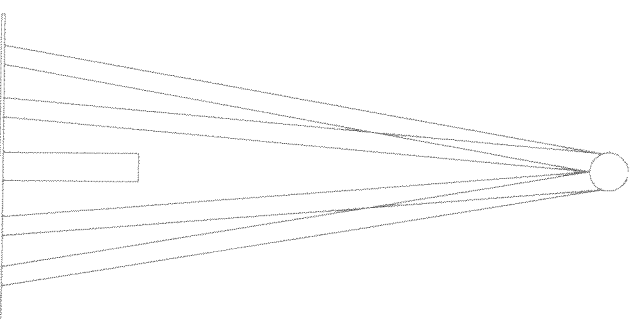

33

33

16

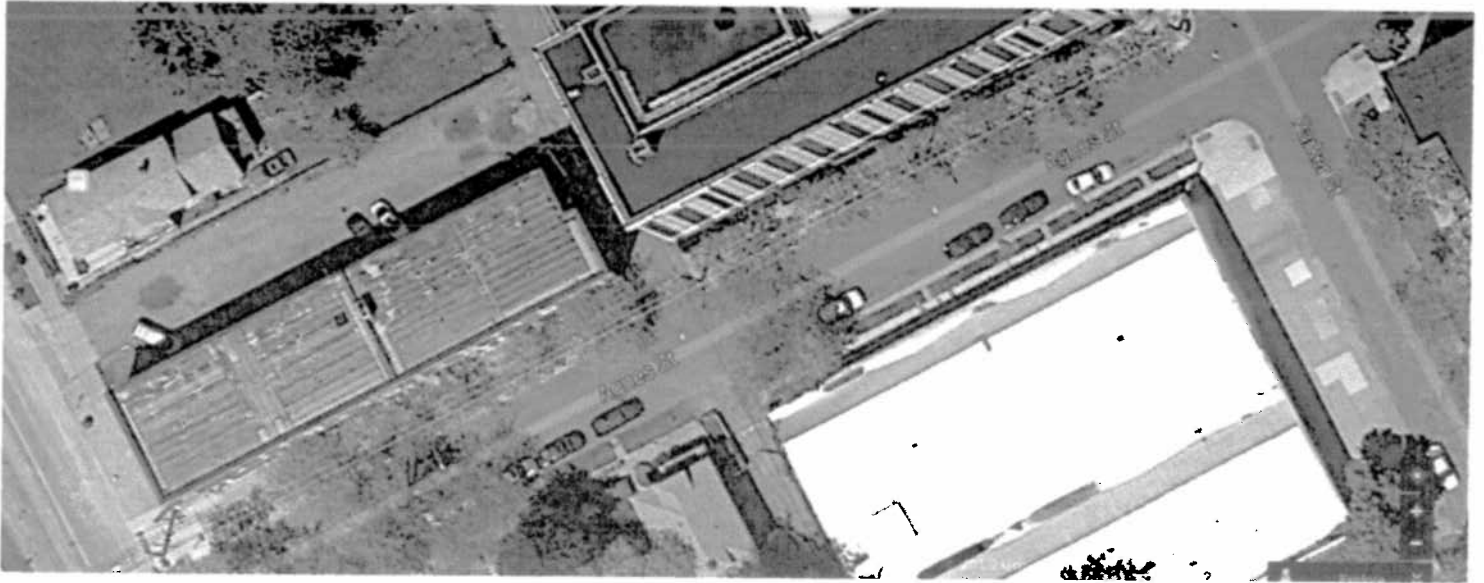









PROVISIONS FOR ENCROACHMENT For Petition 419

Detroit Water and Sewerage (DWSD) agree to the proposed encroachment subject to the fulfilling of the following provisions:

1. By approval of this petition the (DWSD) does not waive any of its rights to its facilities located in the right of way, and at all time, DWSD, its agents or employees, shall have the right to enter upon the right of way to maintain, repair, alter, service, inspect, or install its facilities. All costs incident to the damaging, dismantling, demolishing, removal and replacement of structures or other improvements herein permitted and incurred in gaining access to DWSD's facilities for maintenance, repairing, alteration, servicing or inspection caused by the encroachment shall be borne by the petitioner. All costs associated with gaining access to DWSD's facilities, which could normally be expected had the petitioner not encroached into the right of way shall be borne by DWSD.
2. All construction performed under this petition shall not be commenced until after five (5) days written notice to DWSD. Seventy-two (72) hours notice shall also be provided in accordance with P.A. 53 1974, as amended, utilizing the MISS DIG one call system.
3. Construction under this petition is subject to inspection and approval by DWSD forces. The cost of such inspection shall, at the discretion of DWSD, be borne by the petitioner.
4. If DWSD facilities located within the right of way shall break or be damaged as the result of any action on the part of the petitioner, then in such event the petitioner agrees to be liable for all costs incident to the repair, replacement or relocation of such broken or damaged DWSD facilities.
5. The petitioner shall hold DWSD harmless for any damage to the encroaching device constructed or installed under this petition, which may be caused by the failure of DWSD's facilities.

