

**FAX TRANSMITTAL****Office of the City Clerk**

Coleman A Young Municipal Center  
Two Woodward Avenue, Suite 200  
Detroit, Michigan 48226

Telephone: (313) 224-2070 Fax: (313) 224-2075

*Tuesday, July 29, 2014*

*No. of Pages 4*

**FROM:** *Mr. Andre Gilbert II, Junior Assistant City Council Committee Clerk*

**SUBJECT:** *Petition #361, Giffels Webster, request for encroachment within various rights-of-way for Bicycle Rack Installation. (see attachment)*

**FAX TO THE FOLLOWING DEPARTMENT(S):**

Ms. Trisha Stein, Interim Director

Planning and Development Department (313) 224-1629

Mr. Richard Doherty, City Engineer

DPW - City Engineering Division (313) 224-1464

Attachment

Janice M. Winfrey  
City Clerk

**City of Detroit**  
OFFICE OF THE CITY CLERK

Robin R. Underwood, CMC  
Deputy City Clerk

**DEPARTMENTAL REFERENCE COMMUNICATION**

*Tuesday, July 29, 2014*

*To: The Department or Commission Listed Below*

*From: Janice M. Winfrey, Detroit City Clerk*

---

The following petition is herewith referred to you for report and recommendation to the City Council.

In accordance with that body's directive, kindly return the same with your report in duplicate within four (4) weeks.

---

PLANNING AND DEVELOPMENT DEPARTMENT DPW - CITY ENGINEERING DIVISION

**361** *Giffels Webster, request for encroachment within various rights-of-way for Bicycle Rack Installation. (see attachment)*

**NOTE:** The Detroit City Council is on recess from:  
**JULY 29, 2014 through AUGUST 29, 2014**

The City Clerk requests that Departments directly handle requests which fall within those dates.

**PLEASE EXPEDITE!!!**



# 361

July 24, 2014

HAND DELIVER

Honorable Detroit City Council  
C/o Detroit City Clerk  
200 Coleman A. Young Municipal Center  
2 Woodward Avenue  
Detroit, Michigan 48226

**RE: Request for Encroachment within Various Rights-of-Way for Bicycle Rack Installation**

Giffels Webster, 28 W. Adams, Suite 1200, Detroit, Michigan 48226 on behalf of Midtown Detroit, Inc., 3939 Woodward Avenue, Suite 100, Detroit, Michigan 48201, respectfully requests encroachments within the public rights-of-way located as detailed in "Attachment A".

The proposed encroachments are minor in nature and will consist of the installation of bicycle racks. The encroachments will not impeded pedestrian and vehicular traffic, nor will they interfere with the maintenance of the public rights-of-way including utility company and Fire Department access.

The requested encroachments are critical in developing the non-motorized infrastructure of the greater downtown Detroit area. Drawings of the proposed locations are attached and detailed drawings will be delivered to the City Engineering Division of DPW to be used for their investigation.

If you should have any questions, please do not hesitate to contact me at (P) 313.962.4442, (M) 313.401.6690, (F) 313.962.5068, or e-mail to [mdarqa@giffelswebster.com](mailto:mdarqa@giffelswebster.com).

Respectfully,

A handwritten signature in black ink that reads "Michael G. Darga".

Michael G. Darga,  
Senior Project Manager

Cc: Elise Fields, Midtown Detroit, Inc.



ATTACHMENT "A"

MIDTOWN BIKE RACK INSTALLATION LOCATIONS  
WITHIN CITY OF DETROIT RIGHTS-OF-WAY

Neighborhood	Location No.	Location	Address	Remarks
Midtown	M1	55 W. Canfield Lofts	55 W. Canfield	
	M2	71 Garfield	71 Garfield Street	
	M3	Auburn, The	4240 Cass Avenue	
	M4	Willy's Development	441 W. Canfield	
	M5	Craftworks	8047 Agnes	
	M8	Henry Ford Health System	1 Ford Place	
	M11	Melt	4160 Cass Avenue	
	M12	Metropolitan Center for High Technology	2727 Second Avenue	
	M14	Midtown Dog Park	Cass & Canfield	
	M15	MOCAD	4454 Woodward Avenue	Installed on Garfield
	M16	MSU - Detroit Center	3408 Woodward Avenue	Installed on Erskine
	M17	N'Namdi Center for Contemporary Art	52 East Forest Avenue	
	M18	Third Street Bar	4626 Third Street	
	M19	Selden Standard	3921 Second Avenue	
	M21	Union at Midtown, The	4830 Cass Avenue	
	M22	Woodbridge	5127 Trumbull	
	M24	Cass / Ferry Apartments	100 W. Ferry	
M25	Comerica Bank	4 E. Alexandrine		
Corktown	C1	Bagley Trumbull Market	1701 Trumbull Street	
Downtown	D1	Campus Martius	800 Woodward Avenue	
	D2	Grand Park Centre	28 W. Adams	
New Center	NC2	Fisher Building	3011 W. Grand Boulevard	
	NC3	New Center One Building	3031 W. Grand Boulevard	
	NC4	New Center Park	2998 West Grand Boulevard	
	NC5	Next Energy	461 Burroughs	
	NC6	Peck Park	5050 Brush Street	
	NC7	Tech Town "Living Room"	Cass & Amsterdam	
	NC8	West Boulevard Building	2990 West Grand Boulevard	
	Eastern Market	E1	3 Cats 1 Dog	2472 Riopelle
E2		Detroit Merchantile	3434 Russell	
E4		Omni Corps Detroit	1501 Division	
E5		Red Bull House of Art	1551 Winder	
E6		Signal Return	1345 Division	
E8		Welcome Center	1445 Adelaide	

Date: 24-Jul-14

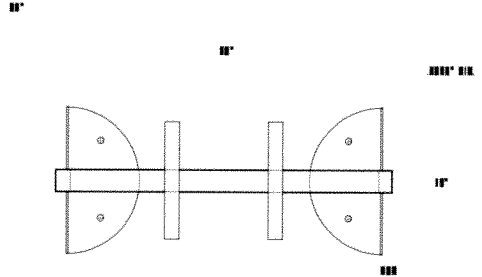
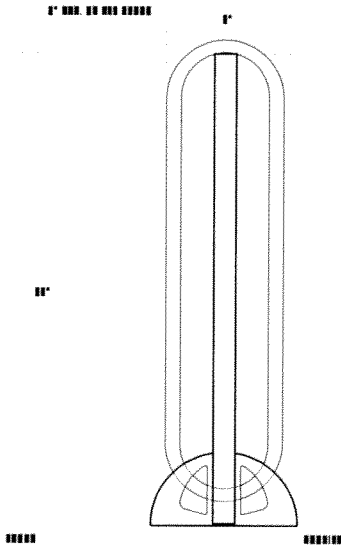
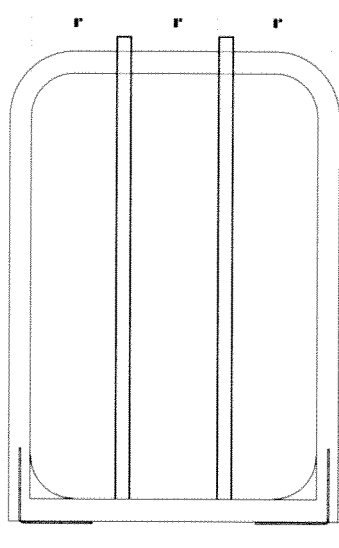

**FIG. 1. FRONT VIEW.**  
 FIG. 2. SIDE VIEW.  
 FIG. 3. TOP VIEW.

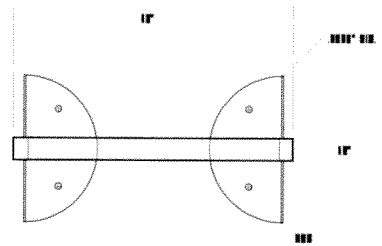
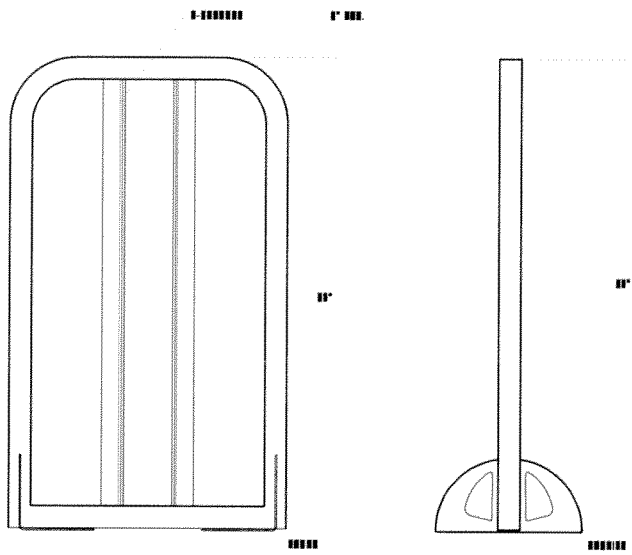

**DOOR HANDLE WITH KEY LOCK AND KEY HOLES - 36" HGT. X 18" WIDE**

City of Detroit  
**City Engineering Division, Department of Public Works**  
**Survey Bureau**

Fifth Notice 2/13/15  
Fourth Notice 1/6/15  
Third Notice 12/5/14  
Second Notice 11/3/14

**NOTICE OF PROPOSED CHANGE IN PROPERTY**

**Date:** 09/17/2014

**Petition:** x361

- AT&T Telecommunication
- Cable Television (CATV)
- Detroit Edison (DTE)
- Michigan Consolidated Gas (DTE)
- Fire Department
- Planning & Development Department
- Public Lighting Dept. - Communication Division
- Public Lighting Dept. - Overhead Line Division
- Public Lighting Dept. - Underground Division
- Police Department
- Recreation Department
- Sanitation Division, DPW
- Street Design Bureau, DPW
- Street Maintenance Division, DPW
- Street and Traffic Division, DPW
- Water and Sewerage Dept. - Sewer Design
- Water and Sewerage Dept. - Water Design
- Vacation
- Conversion to Easement
- Dedication
- Encroachment
- Temporary Closing
- Berm Use

A petition drawing is attached. Property shown on the attached print is proposed to be changed as indicated.

Kindly report (using the back of this sheet) the nature of your services If any) affected by the proposed change and the estimated costs of removing and rerouting such services (if necessary).

Please return one copy to City Engineering Division, DPW. Retain one copy and print for you file.

Alfred Jordan, Director, Department of Public Works

By: Richard Doherty, CED DPW  
Head Engineer

**TO: City Engineering Division, DPW  
65 Cadillac Square, Suite 900  
Detroit, Michigan 48226-2873  
Survey Bureau: 313-224-3970**

x361

The proposed change in property (referred to on the other side of this sheet) would affect our services as follows:

- Not Involved
- Involved; but asking you to hold action on this petition until further notice.
- Involved; but no objections to the property change .
- Involved; but no objections to the property change...provided as easement of the full width of the public right-of-way (street, alley or other public place) is reserved.
- Involved; the nature of our services, and the estimated costs of removing and/or rerouting such services are:

*P*

Fire  
(Utility or City Department)

Chief A. B. Hall  
By

Chief of Plans & Exam  
Title

2/14/15  
Date

(313) 224-134  
Area code - Telephone number