

PETITION NO. 167  
 BEDROCK REAL ESTATE SERVICES  
 1092 WOODWARD AVE.  
 DETROIT, MICHIGAN 48226  
 C/O SCOTT R. COLLINS  
 PHONE NO. 313 373-8700



WITHERELL AVE. 60 FT. WD.

WITHERELL AVE. 60 FT. WD.

WOODWARD AVE. 120 FT. WD.

BROADWAY AVE. 100 FT. WD.

JOHN R. ST. 60 FT. WD.

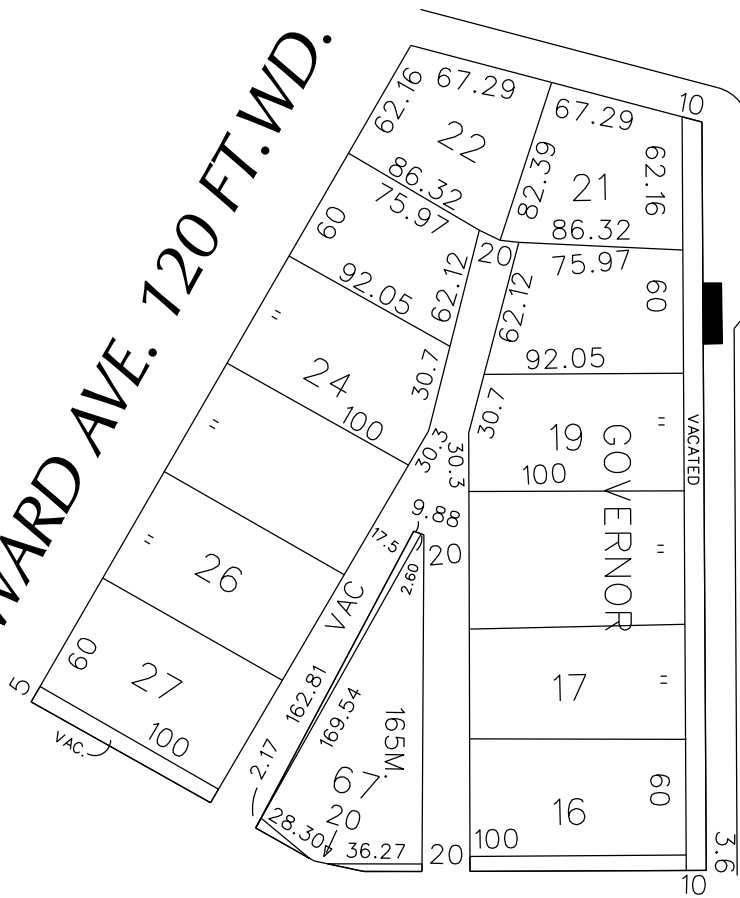
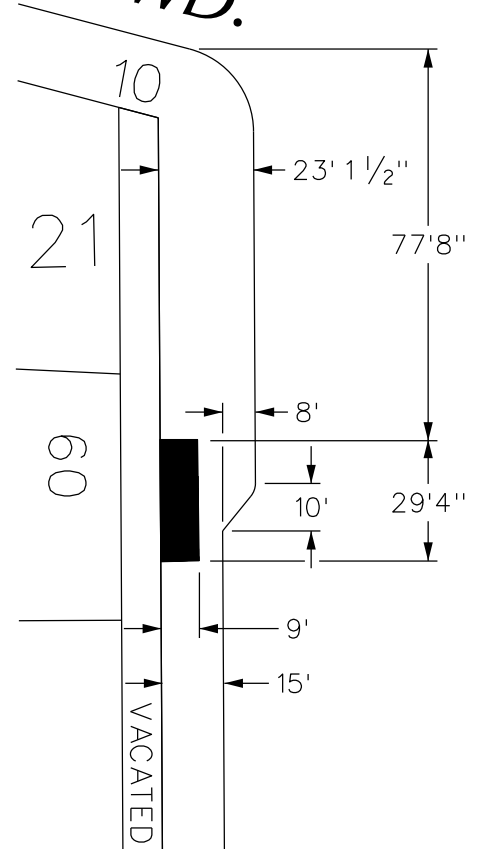

- REQUEST ENCROACHMENT  
 (With Outdoor Seating)

(FOR OFFICE USE ONLY)

CARTO 28 A

B					
A					
DESCRIPTION		DRWN	CHKD	APPD	DATE
REVISIONS					
DRAWN BY	WLW	CHECKED			
DATE	04-08-14	APPROVED			

REQUEST ENCROACHMENT  
 INTO BROADWAY  
 AT 1555 BROADWAY  
 (WITH OUTDOOR SEATING)

CITY OF DETROIT  
 CITY ENGINEERING DEPARTMENT  
 SURVEY BUREAU

JOB NO. 01-01

DRWG. NO. X 167