



City of Detroit
Inter-Departmental Communication

TO: Richard Doherty, City Engineer
City Engineering/Department of Public Works

FROM: Debra Singleton, Manager II
Detroit Water and Sewerage Department

DATE: June 6, 2014

RE: Petition No. 167
Requested Encroachment into Broadway at 1555 Broadway, With Outdoor Seating

We have reviewed the above Petition received by this office on April 22, 2014. With regard to DWSD's interests, our comment is as follows:

- Our records indicate that there are water mains and sewers in Broadway. DWSD has no objection to the requested encroachment provided that the attached Provisions for Encroachment are strictly followed.

If you have any questions, please call me at (313) 267-8309.

Sincerely,

Debra Singleton
Manager II
Claims and Permits

DES//gl

Attachments

CC: Cheryl Porter
Mohamad Farhat

City of Detroit
City Engineering Division, Department of Public Works
Survey Bureau

NOTICE OF PROPOSED CHANGE IN PROPERTY

Date: 4/22/2014

Petition: x167

- | | |
|---|--|
| <input type="checkbox"/> AT&T Telecommunication | |
| <input type="checkbox"/> Cable Television (CATV) | <input type="checkbox"/> Vacation |
| <input type="checkbox"/> Detroit Edison (DTE) | |
| <input type="checkbox"/> Michigan Consolidated Gas (DTE) | <input type="checkbox"/> Conversion to Easement |
| <input type="checkbox"/> Fire Department | <input type="checkbox"/> Dedication |
| <input type="checkbox"/> Planning & Development Department | |
| <input type="checkbox"/> Public Lighting Dept. - Communication Division | <input checked="" type="checkbox"/> Encroachment |
| <input type="checkbox"/> Public Lighting Dept. - Overhead Line Division | |
| <input type="checkbox"/> Public Lighting Dept. - Underground Division | <input type="checkbox"/> Temporary Closing |
| <input type="checkbox"/> Police Department | |
| <input type="checkbox"/> Recreation Department | <input type="checkbox"/> Berm Use |
| <input type="checkbox"/> Sanitation Division, DPW | |
| <input type="checkbox"/> Street Design Bureau, DPW | |
| <input type="checkbox"/> Street Maintenance Division, DPW | |
| <input type="checkbox"/> Street and Traffic Division, DPW | |
| <input type="checkbox"/> Water and Sewerage Dept. - Sewer Design | |
| <input type="checkbox"/> Water and Sewerage Dept. - Water Design | |

A petition drawing is attached. Property shown on the attached print is proposed to be changed as indicated.

Kindly report (using the back of this sheet) the nature of your services (if any) affected by the proposed change and the estimated costs of removing and rerouting such services (if necessary).

Please return one copy to City Engineering Division, DPW. Retain one copy and print for you file.

Alfred Jordan, Director, Department of Public Works

By: Richard Doherty, CED DPW
Head Engineer

**TO: City Engineering Division, DPW
65 Cadillac Square, Suite 900
Detroit, Michigan 48226-2873
Survey Bureau: 313-224-3970**

The proposed change in property (referred to on the other side of this sheet) would affect our services as follows:

- Not Involved
- Involved; but asking you to hold action on this petition until further notice.
- Involved; but no objections to the property change .
- Involved; but no objections to the property change...provided as easement of the full width of the public right-of-way (street, alley or other public place) is reserved.
- Involved; the nature of our services, and the estimated costs of removing and/or rerouting such services are:

(Utility or City Department)

By

Title

Date

Area code – Telephone number

PETITION NO. 167
 BEDROCK REAL ESTATE SERVICES
 1092 WOODWARD AVE.
 DETROIT, MICHIGAN 48226
 C/O SCOTT R. COLLINS
 PHONE NO. 313 373-8700



WITHERELL AVE. 60 FT. WD.

WITHERELL AVE. 60 FT. WD.

WOODWARD AVE. 120 FT. WD.

BROADWAY AVE. 100 FT. WD.

JOHN R. ST. 60 FT. WD.

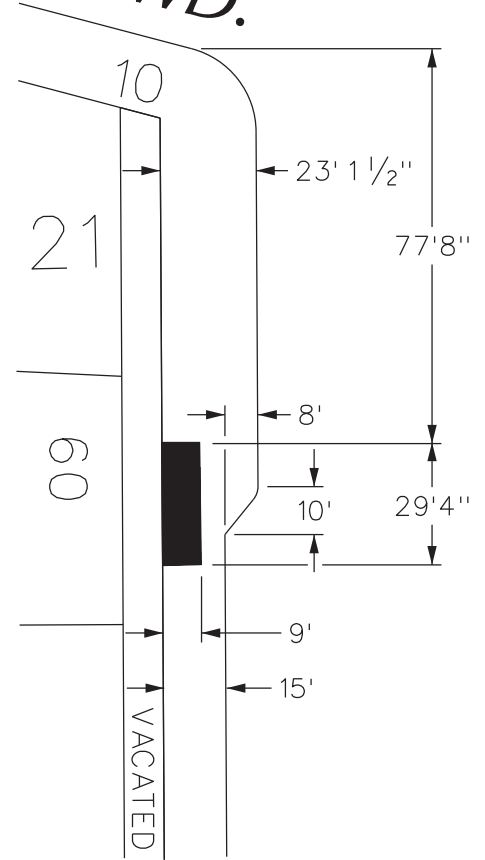

- REQUEST ENCROACHMENT
 (With Outdoor Seating)

(FOR OFFICE USE ONLY)

CARTO 28 A

B					
A					
DESCRIPTION		DRWN	CHKD	APPD	DATE
REVISIONS					
DRAWN BY	WLW	CHECKED			
DATE	04-08-14	APPROVED			

REQUEST ENCROACHMENT
 INTO BROADWAY
 AT 1555 BROADWAY
 (WITH OUTDOOR SEATING)

CITY OF DETROIT
 CITY ENGINEERING DEPARTMENT
 SURVEY BUREAU

JOB NO. 01-01

DRWG. NO. X 167

M@dison
Chez Zara
Outdoor Seating

Detroit, MI

Revisions

Date	04-17-14	Pre-Entry
Drawn	JDS	Construction
Checked	JS	Record
Approved	JS	On 1/4" scale Use figured dimensions only
Below Number		Copyright © 2014

Job Number

2011163

Title

Madison Site Plan
Proposed Outdoor Seating

Scale: 3/32" = 1'-0"

Sheet

A1

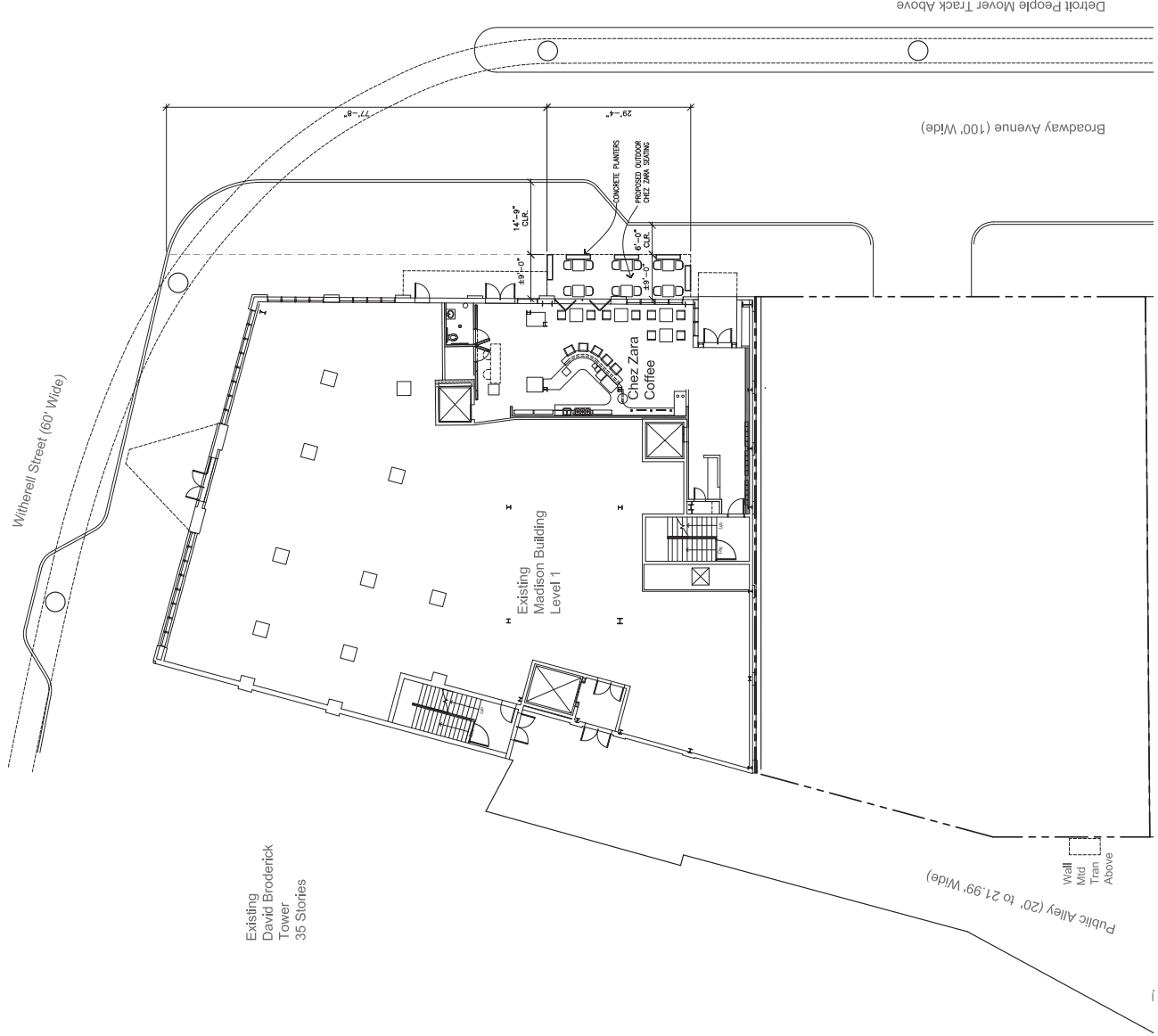

Existing David Broderick Tower 35 Stories

PROVISIONS FOR ENCROACHMENT For Petition 167

Detroit Water and Sewerage (DWSD) agrees to the proposed encroachment subject to the fulfilling of the following provisions:

1. By approval of this petition the (DWSD) does not waive any of its rights to its facilities located in the right of way, and at all time, DWSD, its agents or employees, shall have the right to enter upon the right of way to maintain, repair, alter, service, inspect, or install its facilities. All costs incident to the damaging, dismantling, demolishing, removal and replacement of structures or other improvements herein permitted and incurred in gaining access to DWSD's facilities for maintenance, repairing, alteration, servicing or inspection caused by the encroachment shall be borne by the petitioner. All costs associated with gaining access to DWSD's facilities, which could normally be expected had the petitioner not encroached into the right of way shall be borne by DWSD.
2. All construction performed under this petition shall not be commenced until after five (5) days written notice to DWSD. Seventy-two (72) hours notice shall also be provided in accordance with P.A. 53 1974, as amended, utilizing the MISS DIG one call system.
3. Construction under this petition is subject to inspection and approval by DWSD forces. The cost of such inspection shall, at the discretion of DWSD, be borne by the petitioner.
4. If DWSD facilities located within the right of way shall break or be damaged as the result of any action on the part of the petitioner, then in such event the petitioner agrees to be liable for all costs incident to the repair, replacement or relocation of such broken or damaged DWSD facilities.
5. The petitioner shall hold DWSD harmless for any damage to the encroaching device constructed or installed under this petition, which may be caused by the failure of DWSD's facilities.