

**City of Detroit**  
OFFICE OF THE CITY CLERK

Jackie L. Currie  
City Clerk

**RECEIVED**  
CITY ENGINEERING DIV.-DPW

Vernon C. Allen  
Deputy City Clerk

MAR 18 2003

By \_\_\_\_\_

**DEPARTMENTAL REFERENCE COMMUNICATION**

March 10, 2003

To: The Department or Commission Listed Below

From: Jackie L. Currie  
Detroit City Clerk

The following petition is herewith referred to you for report and recommendation to the City Council.

In accordance with that body's directive, kindly return the same with your report in duplicate within four (4) weeks.

**/PUBLIC WORKS DEPARTMENT - CITY ENGINEERING**  
**DIVISION/WATER AND SEWAGE DEPARTMENT/**

**1195 Fellowship Chapel**, for encroachment into public right of way for irrigation system in the area of Santa Maria, West Outer Drive, Lindsay and Biltmore.

March 5, 2003

Honorable City Council  
Coleman A. Young Municipal Center  
Two Woodward Avenue, Room 200  
Detroit, MI 48226

RE: REQUEST FOR AUTHORIZATION TO ENCROACH INTO  
PUBLIC RIGHT OF WAY FOR IRRIGATION SYSTEM -  
FELLOWSHIP CHAPEL NEW SANCTUARY CONSTRUCTION SITE

To the Honorable Council:

Fellowship Chapel is requesting a petition to encroach into the public right of way to install and maintain an irrigation system surrounding the perimeter of the site of the new sanctuary generally bounded by Santa Maria, West Outer Drive, Lindsay and Biltmore.

It is our understanding that it will be necessary for us to provide access to utility companies if necessary due to their right to access in a public right of way. Any costs associated with disturbance of the irrigation system for this purpose would be at our expense.

We thank you for your consideration of this request.

Respectfully submitted,

FELLOWSHIP CHAPEL



Sylvia Shelby Bradley  
Agent for Fellowship Chapel  
313.961.7884  
243 W. Congress, Suite 350  
Detroit, MI 48226

6 MAR 05 11:01

--CITY CLERK--

**City of Detroit**  
OFFICE OF THE CITY CLERK

Jackie L. Currie  
City Clerk

Vernon C. Allen  
Deputy City Clerk

**DEPARTMENTAL REFERENCE COMMUNICATION**

March 10, 2003

To: The Department or Commission Listed Below

From: Jackie L. Currie  
Detroit City Clerk

**RECEIVED**  
CITY ENGINEERING DIV.-DPWM  
MAR 26 2003

By \_\_\_\_\_

The following petition is herewith referred to you for report and recommendation to the City Council.

In accordance with that body's directive, kindly return the same with your report in duplicate within four (4) weeks.

**/PUBLIC WORKS DEPARTMENT - CITY ENGINEERING**  
**DIVISION/WATER AND SEWAGE DEPARTMENT/**

**1195 Fellowship Chapel**, for encroachment into public right of way for irrigation system in the area of Santa Maria, West Outer Drive, Lindsay and Biltmore.

*Handwritten signature:* CED  
Mistis

March 5, 2003

Honorable City Council  
Coleman A. Young Municipal Center  
Two Woodward Avenue, Room 200  
Detroit, MI 48226

RE: REQUEST FOR AUTHORIZATION TO ENCROACH INTO  
PUBLIC RIGHT OF WAY FOR IRRIGATION SYSTEM -  
FELLOWSHIP CHAPEL NEW SANCTUARY CONSTRUCTION SITE

To the Honorable Council:

Fellowship Chapel is requesting a petition to encroach into the public right of way to install and maintain an irrigation system surrounding the perimeter of the site of the new sanctuary generally bounded by Santa Maria, West Outer Drive, Lindsay and Biltmore.

It is our understanding that it will be necessary for us to provide access to utility companies if necessary due to their right to access in a public right of way. Any costs associated with disturbance of the irrigation system for this purpose would be at our expense.

We thank you for your consideration of this request.

Respectfully submitted,

FELLOWSHIP CHAPEL



Sylvia Shelby Bradley  
Agent for Fellowship Chapel  
313.961.7884  
243 W. Congress, Suite 350  
Detroit, MI 48226

MAR 05 11 01

RECEIVED

**City of Detroit**  
OFFICE OF THE CITY CLERK

Jackie L. Currie  
City Clerk

Vernon C. Allen  
Deputy City Clerk

**DEPARTMENTAL REFERENCE COMMUNICATION**

March 17, 2003

**RECEIVED**  
CITY ENGINEERING DIV.-DPW

**MAR 26 2003**

To: The Department or Commission Listed Below

From: Jackie L. Currie  
Detroit City Clerk

By \_\_\_\_\_

The following petition is herewith referred to you for report and recommendation to the City Council.

In accordance with that body's directive, kindly return the same with your report in duplicate within four (4) weeks.

**/PUBLIC WORKS DEPARTMENT - CITY ENGINEERING DIVISION/**

**1242 Duane Harrison, for encroachment in area of 14935 Freeland.**

*LED -  
Mrs. Foster*

TO THE HONORABLE CITY COUNCIL

3-11-03

HELLO MY NAME IS DUANE HARRISON I PRESENTLY RESIDE AT 14935 FREELAND. WHEN I PURCHASED MY HOME FOUR YEARS AGO IT WAS WAS A SINGLE FAMILY DWELLING WITH A SINGLE CAR GARAGE. RECENTLY MY PLAN WAS TO ENLARGE MY GARAGE TO A (3) CAR GARAGE AND MY CONSTRUCTION CO. INFORMED ME MY GARAGE WAS IMPROPERLY PLACED ON THE EASEMENT ROUGHLY 18" TO 2'0. WE'RE HERE TO TAKE CARE OF THIS ISSUE AS WE DISCUSSED WITH JOE MAPLES IN BUILDING AND ZONING. WE WOULD LIKE TO START THE CONSTRUCTION AS SOON AS POSSIBLE AND YOUR COOPERATION WOULD GREATLY BE APPRECIATED

THANK YOU

Duane Harrison  
14935 FREELAND ST  
DET MI 48227  
Home 313-837-0496  
Cell 313-779-7900

CITY CLERK

MAR 03 3:45

## PETITION REQUESTS

Requests should answer the following five questions:

1. **Who** LIKE TO INTRODUCE MYSELF D.H.
2. **What** WANTING TO ADD A 2-CAR GARAGE
3. **Where** AT 14935 FREELAND
4. **When** AS SOON AS POSSIBLE
5. **Why** BECAUSE WE OWN THREE VEH. & WOULD LIKE TO SECURE THEM

*Petitioner must provide name, address and phone number.*

Address your request to: **The Honorable City Council**

Forward your request to: **Jackie L. Currie, City Clerk**  
**200 Coleman A. Young Municipal Center**  
**Detroit, MI 48226**

*Requests can be forwarded to the City Clerk's office either by mail or in person.*

--CITY CLERK--

11 MAR 05 0:45

GEORGE JEROME & C



PRISM MORTGAGE COMPANY

CONSULTING MUNICIPAL & CIVIL ENGINEERS - SURVEYORS. 28204 HAYES • ROSEVILLE, MI 48046 • (810) 774-3000

LEGAL DESCRIPTION OF PROPERTY (AS FURNISHED BY CLIENT) DATE: 4-21-99  
Lot 172, B.E. TAYLOR'S COMMODORE SUBDIVISION, lying North of Grand River Ave.,  
Greenfield Township (now City of Detroit), Wayne County, Michigan, Being a  
part of the W. 1/2 of the N.E. 1/4 of Sec. 19, T.1 S., R.11 E. Recorded in  
Libar 41 of Plats, Page 32 of Wayne County Records.

ENCROACHMENT

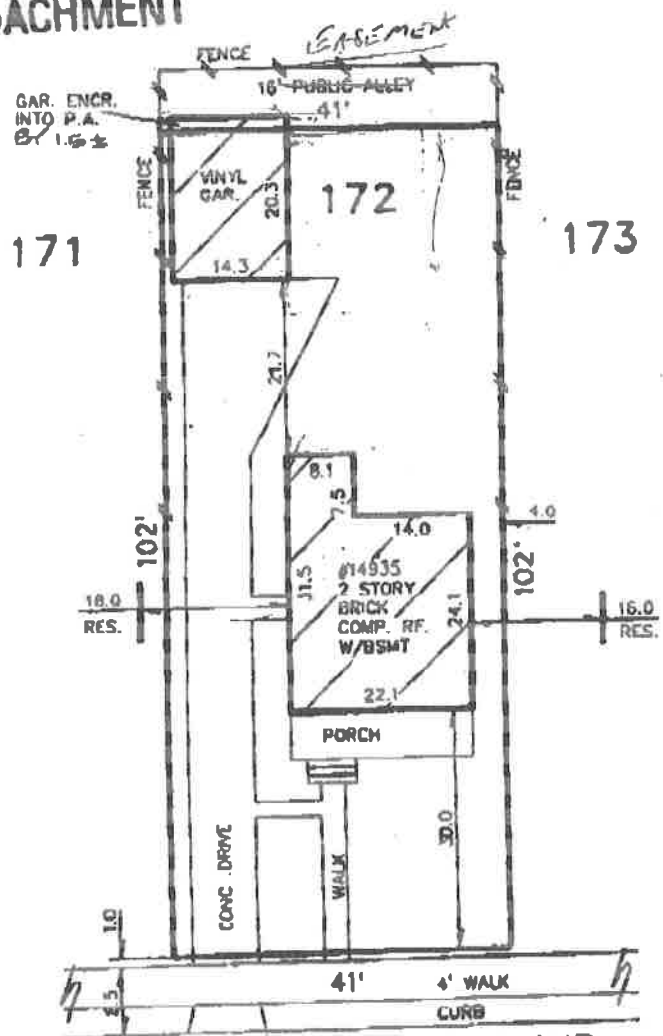



**City of Detroit**  
OFFICE OF THE CITY CLERK

Jackie L. Currie  
City Clerk

Vernon C. Allen  
Deputy City Clerk

**DEPARTMENTAL REFERENCE COMMUNICATION**

March 17, 2003

To: The Department or Commission Listed Below

From: Jackie L. Currie  
Detroit City Clerk

The following petition is herewith referred to you for report and recommendation to the City Council.

In accordance with that body's directive, kindly return the same with your report in duplicate within four (4) weeks.

**/PUBLIC WORKS DEPARTMENT - CITY ENGINEERING DIVISION/**

**1242 Duane Harrison, for encroachment in area of 14935 Freeland.**



TO THE HONORABLE CITY COUNCIL

3-11-03

HELLO MY NAME IS DUANE HARRISON. I PRESENTLY RESIDE AT 14935 FREELAND. WHEN I PURCHASED MY HOME FOUR YEARS AGO IT WAS WAS A SINGLE FAMILY DWELLING WITH A SINGLE CAR GARAGE. RECENTLY MY PLAN WAS TO ENLARGE MY GARAGE TO A (3) CAR GARAGE AND MY CONSTRUCTION CO. INFORMED ME MY GARAGE WAS IMPROPERLY PLACED ON THE EASEMENT ROUGHLY 18" TO 2'-0. WE'RE HERE TO TAKE CARE OF THIS ISSUE AS WE DISCUSSED WITH JOE MAPLES IN BUILDING AND ZONING. WE WOULD LIKE TO START THE CONSTRUCTION AS SOON AS POSSIBLE AND YOUR COOPERATION WOULD GREATLY BE APPRECIATED.

THANK YOU

Duane Harrison  
14935 FREELAND ST  
DET MI 48227  
Home 313-837-0496  
Cell 313-779-7900

--CITY CLERK--

11 MAR 03 8:45

## PETITION REQUESTS

Requests should answer the following five questions:

1. **Who** LIKE TO INTRODUCE MYSELF D.H.
2. **What** WANTING TO ADD A 2-CAR GARAGE
3. **Where** AT 14935 FREELAND
4. **When** AS SOON AS POSSIBLE
5. **Why** BECAUSE WE OWN THREE VEH. : WOULD LIKE TO SECURE THEM

*Petitioner must provide name, address and phone number.*

Address your request to: **The Honorable City Council**

Forward your request to: **Jackie L. Currie, City Clerk**  
200 Coleman A. Young Municipal Center  
Detroit, MI 48226

*Requests can be forwarded to the City Clerk's office either by mail or in person.*

--CITY CLERK--

1 MAR 03 8:45



PRISM MORTGAGE COMPANY

CONSULTING MUNICIPAL & CIVIL ENGINEERS - SURVEYORS. 29304 HAYES - ROSEVILLE, MI 48066 - (810) 774-3000

LEGAL DESCRIPTION OF PROPERTY (AS FURNISHED BY CLIENT)

DATE: 4-21-99

Lot 172, B.E. TAYLOR'S COMMODORE SUBDIVISION, lying North of Grand River Ave., Greenfield Township (now City of Detroit), Wayne County, Michigan. Being a part of the W. 1/2 of the N.E. 1/4 of Sec. 19, T.1 S., R.11 E. Recorded in Liber 41 of Plats, Page 32 of Wayne County Records.

ENCROACHMENT

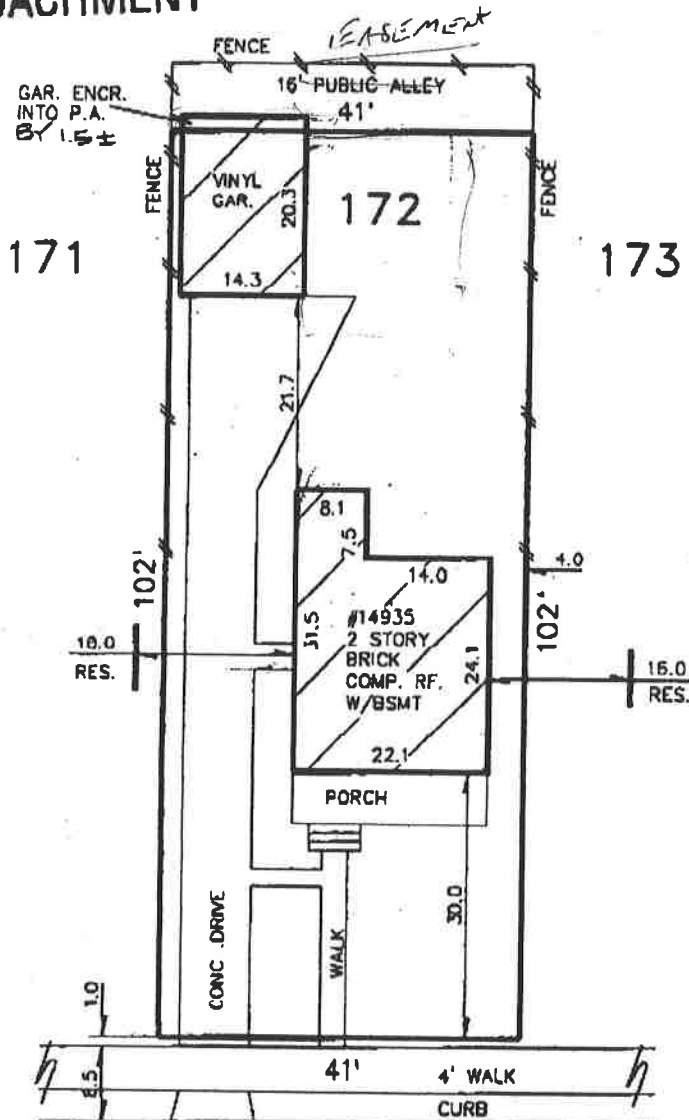

FREELAND AVE. 50' WD.