

CITY OF DETROIT
DEPARTMENT OF PUBLIC WORKS
CITY ENGINEERS OFFICE

PLANS FOR PROPOSED
CURB AND WALK REPLACEMENT ON:
BLAINE —FROM TWELFTH TO BYRON
LEE PLACE—FROM TWELFTH TO BYRON

VIRGINIA PARK N.D.P. MICH. A-4-2
FOR
COMMUNITY DEVELOPMENT COMMISSION

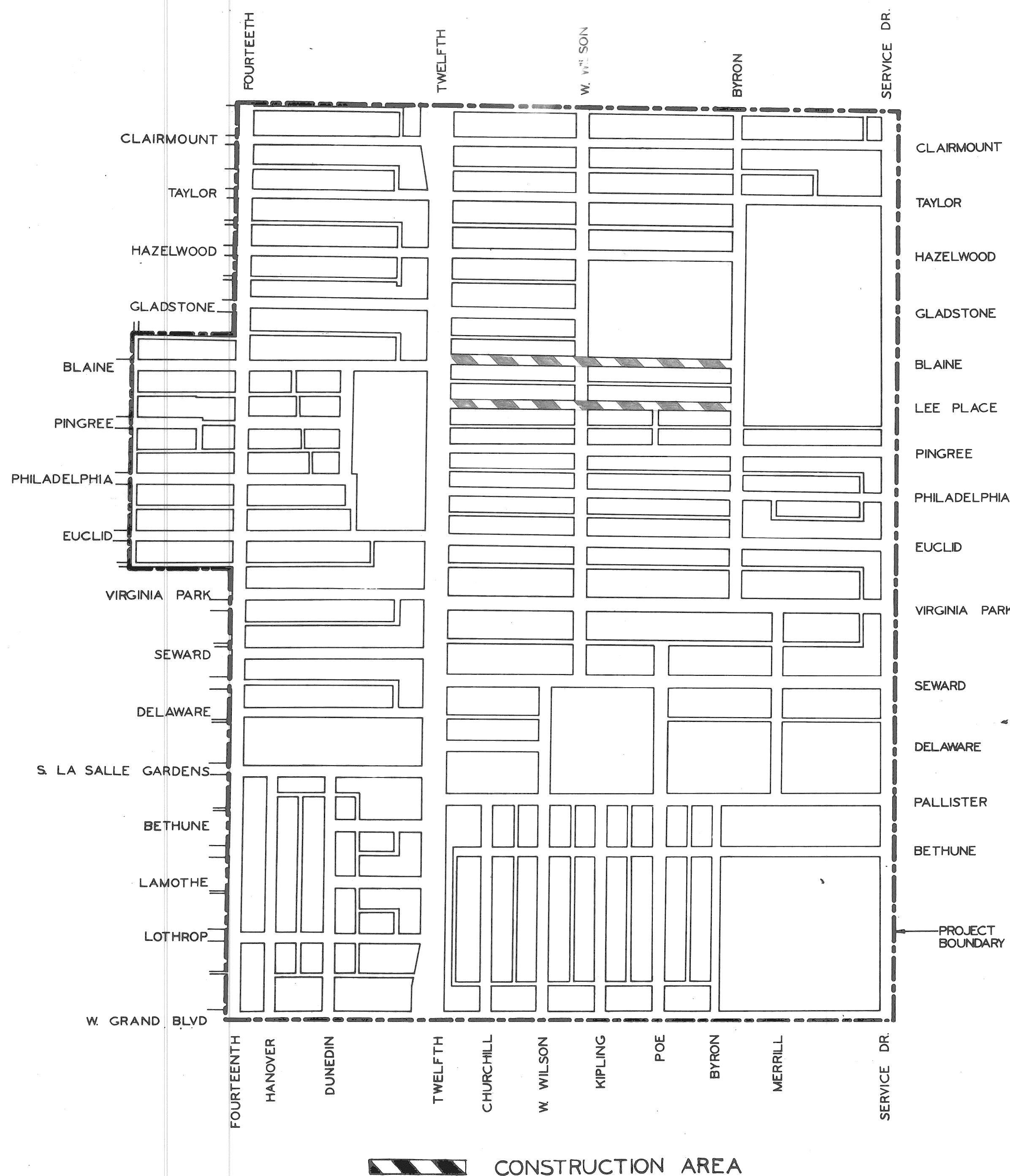

INDEX OF SHEETS

1. TITLE SHEET
2. DETAILS AND QUANTITIES
3. PLAN

477051

PROJECT CURB AND WALK REPLACEMENT ON: BLAINE—FROM TWELFTH TO BYRON LEE PLACE—FROM TWELFTH TO BYRON VIRGINIA PARK N.D.P. MICH. A-4-2	CONTRACT NO. PW 6528 1973 GROUP NO. 2
PLANS PREPARED BY DEPARTMENT OF PUBLIC WORKS CITY ENGINEERS OFFICE	
RECOMMENDED FOR APPROVAL <small>ENGINEER OF INSPECTION</small>	 _____ <small>ENGINEER OF INSPECTION</small>
RECOMMENDED FOR APPROVAL <small>HIGHWAY ENGINEER</small>	 _____ <small>HIGHWAY ENGINEER</small>
APPROVED <small>ASSOCIATE CITY ENGINEER</small>	 _____ <small>ASSOCIATE CITY ENGINEER</small>
APPROVED <small>CITY ENGINEER</small>	 _____ <small>CITY ENGINEER</small>
DATE 12-21-72	DRWG. NO. 1

DESCRIPTION OF ITEM	UNIT	BLAINE				LEE PLACE				TOTAL
		TWELFTH TO WOODROW WILSON		WOODROW WILSON TO BYRON		TWELFTH TO WOODROW WILSON		WOODROW WILSON TO BYRON		
		NORTH SIDE	SOUTH SIDE	NORTH SIDE	SOUTH SIDE	NORTH SIDE	SOUTH SIDE	NORTH SIDE	SOUTH SIDE	
SEPARATE TYPE CURB REPLACEMENT	LFT					166	144			310
SIDEWALK REPLACEMENT	4" SFT	4680	4319	760	4312	3480	3284	5004	3121	28,960
	6" SFT	80	40		280		50	40		490
INTEGRAL CURB & WALK REPLACEMENT	2'WD. LFT	698	666	864	834	538	542	713	725	5580
BEEM GRADING	SYDS	399	416							815
DRIVEWAY REMOVAL	SFT	64	32		272		190	57		615
STUMP REMOVAL	EA.									
SIDEWALK 4" STD.	SFT			30	30					60
DRIVEWAY 6" STD.	SFT	64	32		272		190	57		615
JOINT SAWING	LFT				100				100	200
SODDING	SYDS	234	227	274	274	170	170	206	198	1753
MAINTAINING TRAFFIC	LUMP SUM									

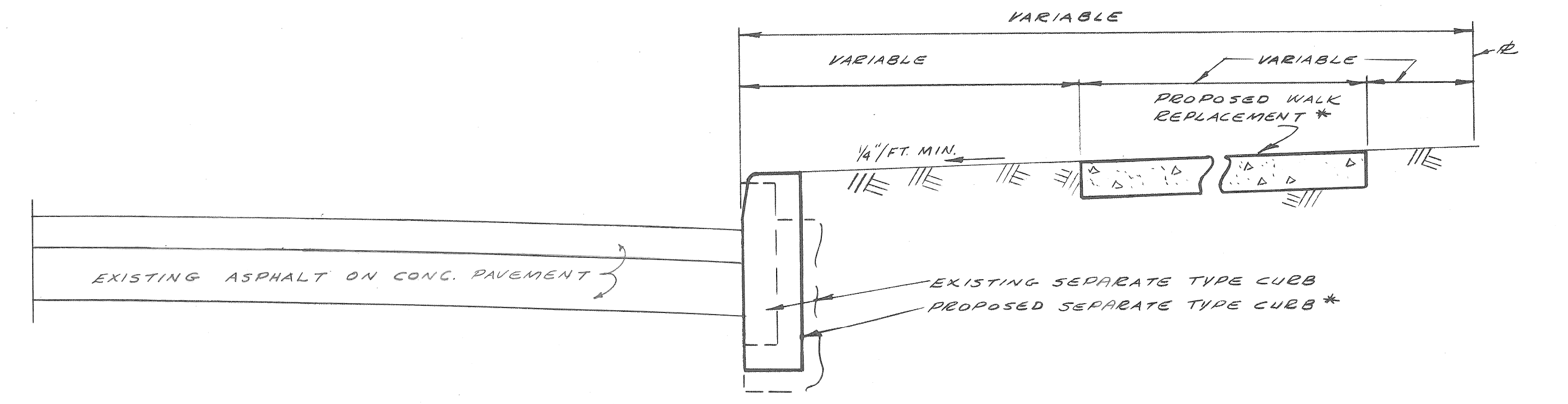
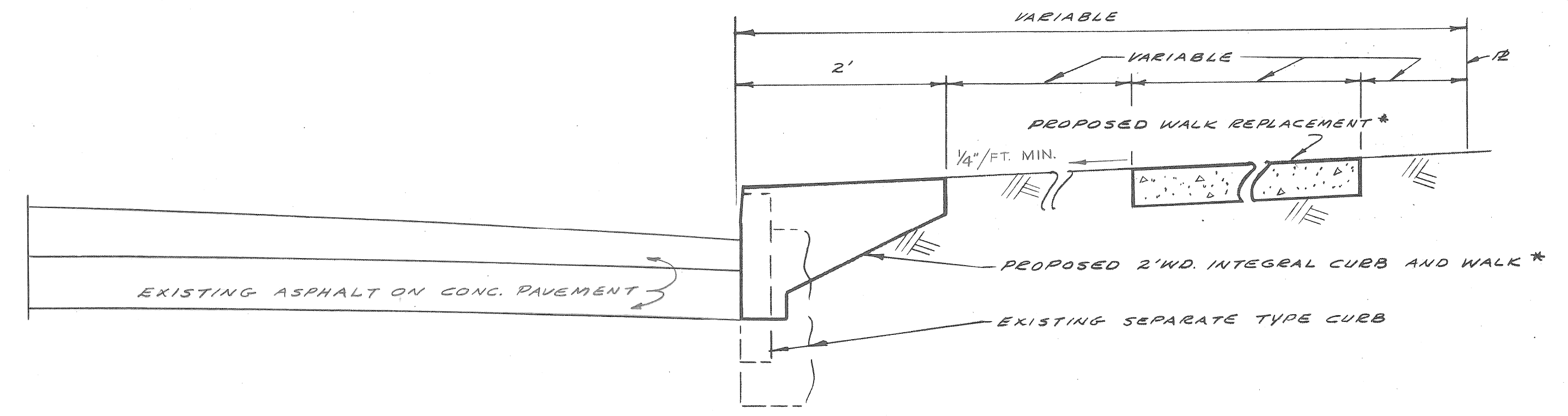

*SEE NOTE #1

TYPICAL CURB AND WALK SECTIONS
NO SCALE

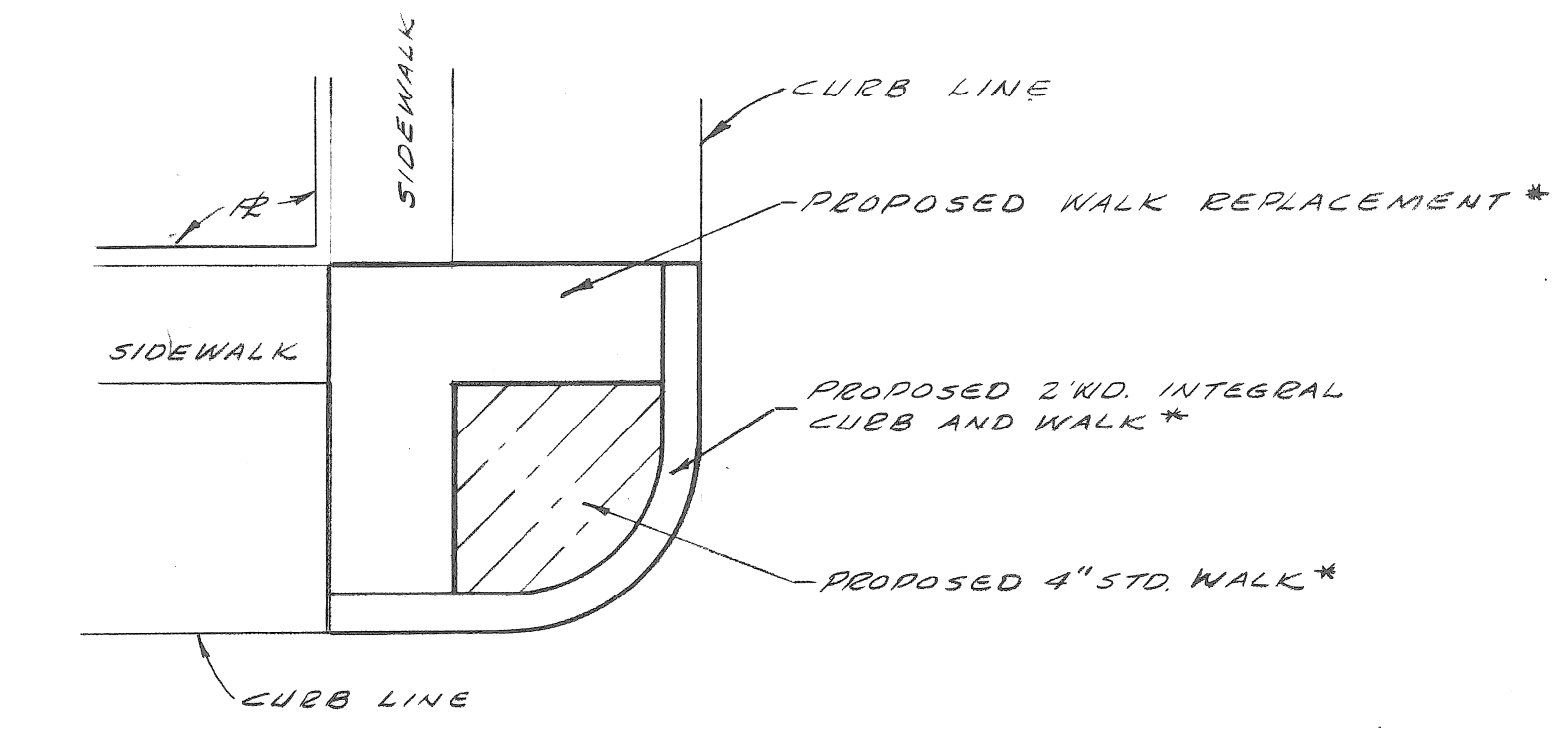

TYPICAL INTERSECTION
NO SCALE

NOTES

- 1- LOCATION OF PROPOSED NEW CONSTRUCTION OR REPLACEMENT INDICATED ON THE TYPICAL SECTIONS SHALL BE AS CALLED FOR ON THE PLANS OR AS DIRECTED BY THE ENGINEER.
- 2- WHERE SEPARATE TYPE CURB OR INTEGRAL TYPE CURB AND WALK ARE CALLED FOR, SEE STD. DET. DRWG'S. NO. C-4381 AND NO. C-4550.
- 3- CONSTRUCT INTEGRAL CURB AND WALK IN THIS CONTRACT. EXCEPT AT TREE LOCATIONS - SEE DETAIL SHEET 3 OF 3.
- 4- COST FOR REMOVAL OF EXISTING CURB BACKING WILL NOT BE PAID FOR SEPARATELY BUT WILL BE PAID FOR AS PART OF THE ITEMS IN THE PROPOSAL FOR "SEPARATE TYPE CURB REPLACEMENT" AND "INTEGRAL CURB AND WALK REPLACEMENT."

DESIGNED BY	TALLEY	APPROVED:	<i>Richard</i>
DRAWN BY	TALLEY	ENGINEER OF STREETS	
TRACED BY		ENGINEER OF EXPRESSWAYS	
CHECKED BY	DEEM		

CITY OF DETROIT
 DEPARTMENT OF PUBLIC WORKS
 CITY ENGINEERS OFFICE
 FOR
COMMUNITY DEVELOPMENT COMMISSION

CURB AND WALK REPLACEMENT ON BLAINE
 FROM TWELFTH TO BYRON
 AND ON LEE PLACE FROM TWELFTH TO BYRON
 VIRGINIA PARK NDP MICH A-4-2
 DETAILS AND QUANTITIES

1973 - GROUP NO. 2
SHEET 2 OF 3 SHEETS
CONTRACT No. PW 6528
ASSIGN. NO. A0.2132
DATE 12-21-72

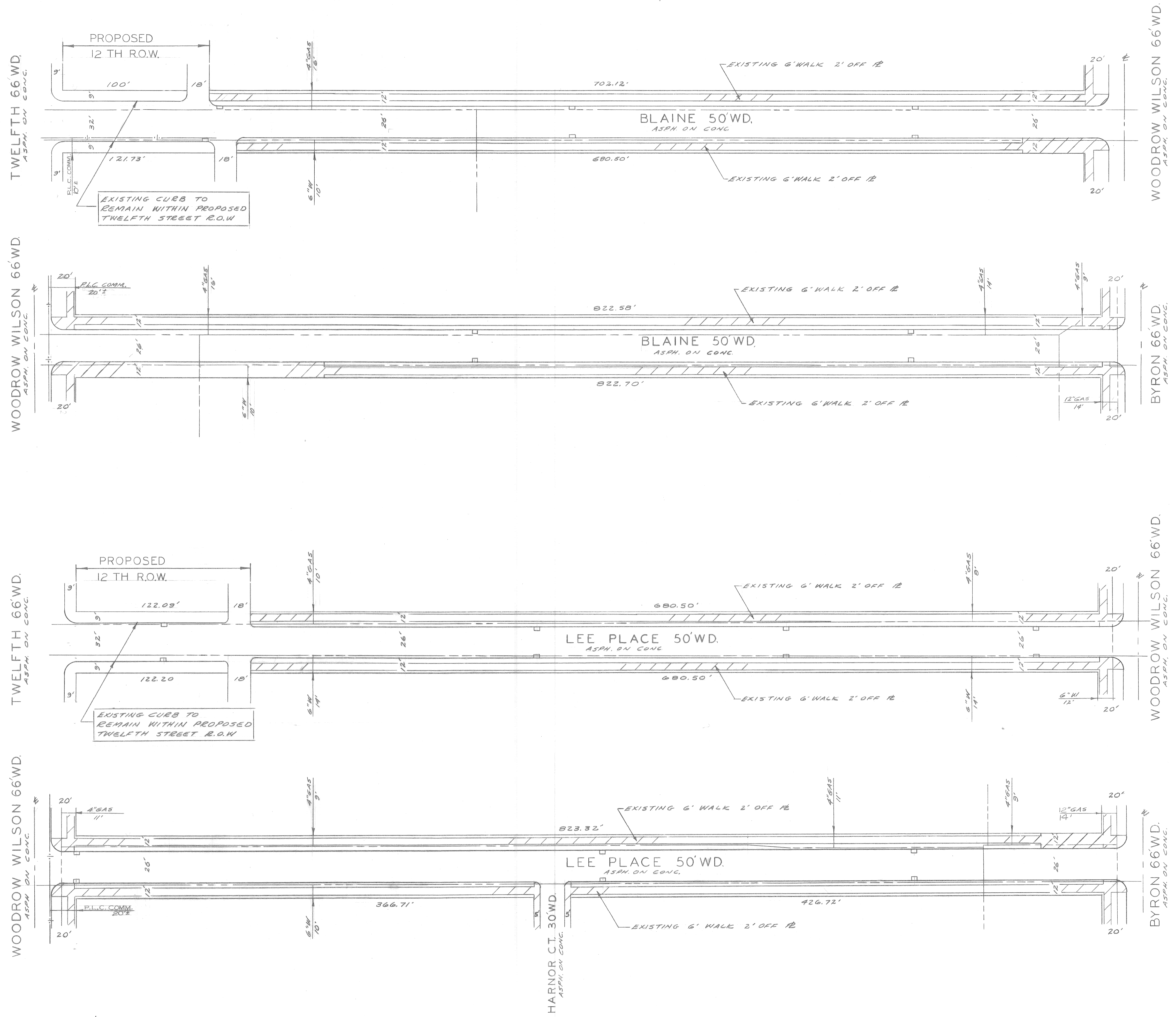
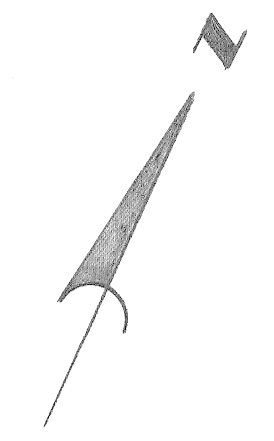

- NOTES**
1. BEFORE STARTING CONSTRUCTION - CONTRACTOR MUST CHECK WITH UTILITIES FOR LOCATIONS OF EXISTING STRUCTURES WHETHER OR NOT INDICATED ON THE PLANS.
 2. REPLACE ALL CURBS IN THIS CONTRACT EXCEPT AS INDICATED.
 3. CONSTRUCT INTEGRAL CURB AND SIDEWALK IN THIS CONTRACT EXCEPT AT TREE LOCATIONS - SEE DETAIL THIS SHEET.
 4. BACKFILLING OF THE BERM AREA WITH SELECTED EXCAVATED MATERIAL OR TOPSOIL SHALL BE INCIDENTAL TO THE COST OF BERM GRADING.
 5. THE REPLACEMENT OF WALKS AND DRIVES SHALL BE AT SUCH LOCATIONS AS DESIGNATED BY THE ENGINEER.
 6. FOR DETAILED QUANTITIES AND CROSS-SECTIONS SEE SHEET # 2.
 7. FOR UTILITY LEGEND SEE STD. DET. DRWG. NO. C-902-A
 8. WHERE SIDEWALK REPLACEMENT IN DRIVEWAY AREA IS DIRECTED BY THE ENGINEER CONSTRUCT 6" SIDEWALK

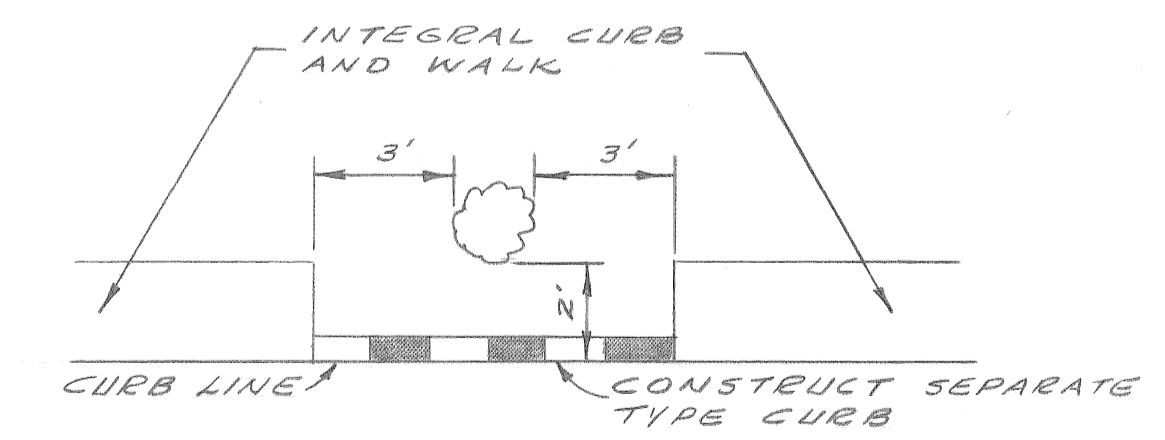

CURB DETAIL AT TREES
SCALE 1"=4'

SCALE: 1"=40'

446853

1973 - GROUP NO.2

DESIGNED BY <i>TALLEY</i> DRAWN BY <i>TALLEY</i> TRACED BY CHECKED BY <i>D.E.M. MCKAY</i>		APPROVED: <i>J. Erickson</i> ENGINEER OF STREETS <i>Allen E. Hagan</i> ENGINEER OF EXPRESSWAYS		CITY OF DETROIT DEPARTMENT OF PUBLIC WORKS CITY ENGINEERS OFFICE FOR COMMUNITY DEVELOPMENT COMMISSION				CURB AND WALK REPLACEMENT ON BLAINE FROM TWELFTH TO BYRON AND ON LEE PLACE FROM TWELFTH TO BYRON. VIRGINIA PARK NDP MICH. A-4-2 PLAN				SHEET <u>3</u> OF <u>3</u> SHEETS CONTRACT NO. PW 6528 ASSIGN. NO. AO 2132 DATE 12-21-72	
REVISIONS LOCATED BY COORDINATES ON SHEET													