

MICHIGAN
DEPARTMENT OF TRANSPORTATION
 IN CO-OPERATION WITH
CITY OF DETROIT
DEPARTMENT OF PUBLIC WORKS
CITY ENGINEERING DIVISION
 AND
FEDERAL HIGHWAY ADMINISTRATION

THE IMPROVEMENTS COVERED BY THESE PLANS SHALL BE DONE IN ACCORDANCE WITH THE MICHIGAN DEPARTMENT OF TRANSPORTATION 1990 STANDARD SPECIFICATIONS AND SUPPLEMENTAL SPECIFICATIONS.

1995 2015
 A.D.T. 10,170 12,200
 D.H.V.
 COMM. % 30%
 DESIGN SPEED 35 MPH

PART 1
ROAD
PLANS **SHEET**
 NUMBERS

TITLE	1
TYPICAL CROSS SECTIONS	2
MISCELLANEOUS DETAILS	3
NOTE SHEET	4
STANDARD SYMBOLS	5
OVERVIEW OF PROJECT	6
QUANTITIES	7
SPECIAL DETAILS	8,9
MAINTAINING TRAFFIC/CONSTRUCTION STAGING	10-19

PLANS OF PROPOSED
~~MICHIGAN~~ PROJECT FEDERAL STP 9582(106)
 CONTROL SECTION SUG ~~82194~~ & ~~STU~~ 82400
 JOB NUMBER 39004 A
 ITEM NUMBER JJ 0264

I - 75
 WAYNE COUNTY
 CITY OF DETROIT

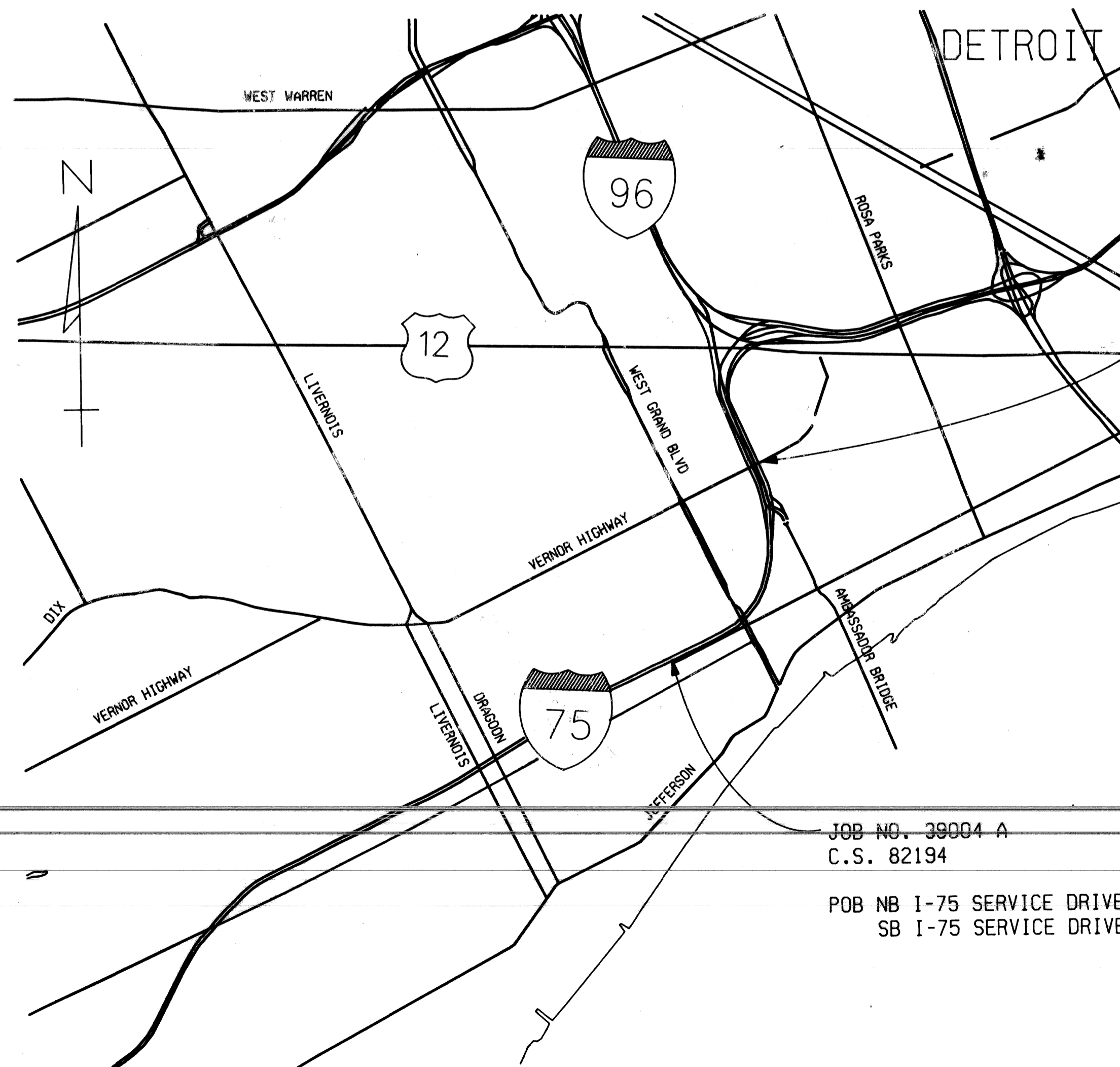

JOB NO. 39004 A
 C.S. 82194

POE NB I-75 SERVICE DRIVE STA 1251+10
 SB I-75 SERVICE DRIVE STA 1247+25

JOB NO. 39004 A
 C.S. 82194

POB NB I-75 SERVICE DRIVE STA 1190+09
 SB I-75 SERVICE DRIVE STA 1195+70

TITLE SHEET LEGEND

PROPOSED PROJECT	=====
EXISTING ROADS	
PAVED	=====
BITUMINOUS	-----
GRAVEL	-----
UNIMPROVED OR CITY STREET	-----
SECTION LINE	-----
TOWNSHIP LINE	-----
COUNTY LINE	-----
CITY OR VILLAGE LIMITS	-----
RAILROADS	-----

CONTRACT FOR: I-75 SERVICE DRIVES - PAVEMENT REPAIR AND RESURFACING

LOCAL AUTHORITY APPROVAL
 CITY OF DETROIT
 CITY ENGINEERING DIVISION
 DEPARTMENT OF PUBLIC WORKS

APPROVED BY: *William R. Erben* 6/28/95
 DATE

APPROVED BY: *William R. Erben* 6/28/95
 CITY ENGINEER DATE

PREPARED UNDER THE SUPERVISION OF

William R. Erben 6/26/95
 WILLIAM R. ERBEN - MDT DISTRICT DESIGN ENGINEER
 (REGISTERED PROFESSIONAL ENGINEER) DATE

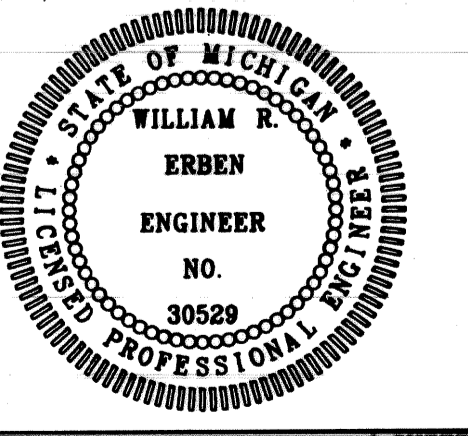

CONTROL SECTION	JOB NUMBER	FEDERAL NUMBERS		SHEET NO.
		PROJECT	ITEM	
SUG 82194 & STU 82400	39004 A			1

SH. NO. 1
 JOB NO. 39004 A
 CONTROL SECTION 82194

STP 9582(106) JJ 0264

SUG 82194 & STU 82400 - 39004 A

©

FINAL R.O.W.			
AUTH	DATE	NO.	REVISION

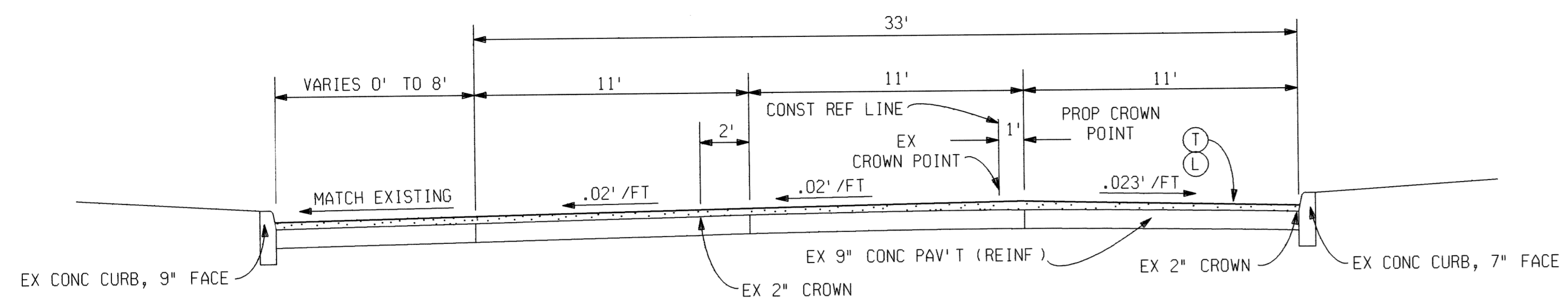

TYPICAL NB RAMP TRANSITION SECTION

TO APPLY: NORTHBOUND SERVICE DRIVE, STA 1190+52 (POB) TO STA 1197+52 AND STA 1223+68 TO STA 1225+54

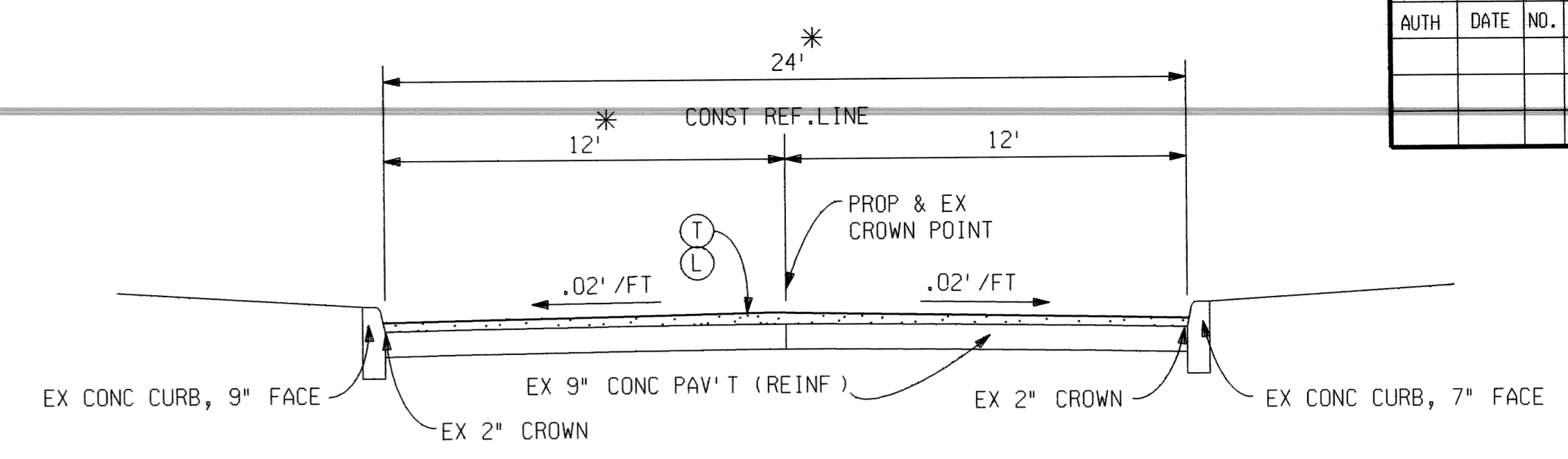

TYPICAL 24' SERVICE ROAD SECTION

TO APPLY: NORTHBOUND SERVICE DRIVE, STA 1197+52 TO STA 1223+68
SOUTHBOUND SERVICE DRIVE, STA 1202+77 TO STA 1205+94

* NOTE: NB SERVICE DRIVE, STA 1220+93 TO 1223+68, LEFT LANE TAPERS FROM 12' TO 1' AND CROSS SECTION WIDTH VARIES FROM 24' TO 13'.

- GENERAL NOTES:
1. ALL STATIONS SHOWN ARE APPROXIMATE.
 2. A PORTION OF THE SOUTHBOUND SERVICE DRIVE, FROM STA 1205+94 TO STA 1216+14 (LAFAYETTE ST), HAS BEEN OMITTED FROM RESURFACING.
 3. FOR NORTHBOUND SERVICE DRIVE, STA 1237+60 TO STA 1238+43, SEE PORTER STREET TYPICAL.
 4. AN ADDITIONAL QUANTITY OF BIT MIX 3C HAS BEEN INCLUDED FOR WEDGING TO ACHIEVE PROPOSED CROSS SLOPES.

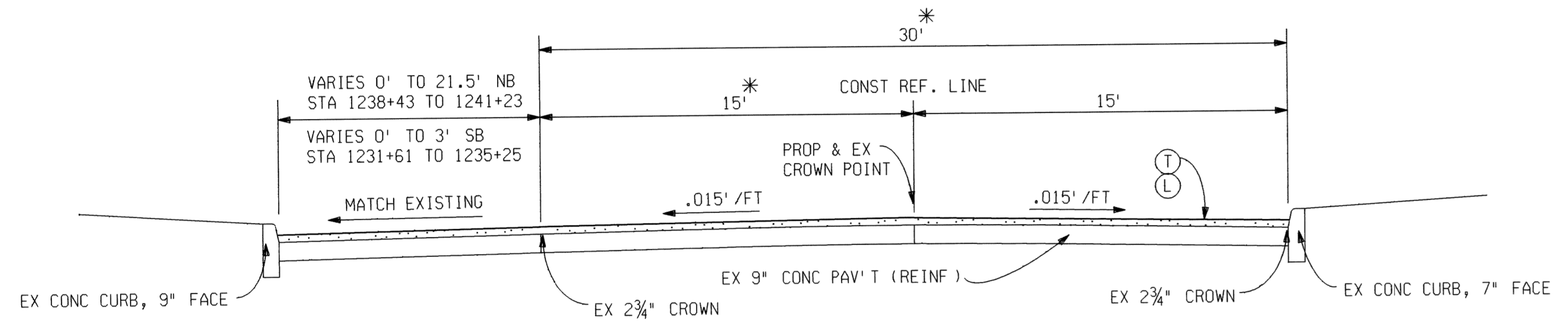

TYPICAL 30' SERVICE ROAD SECTION

TO APPLY: NORTHBOUND SERVICE DRIVE, STA 1225+54 TO STA 1237+60 AND STA 1238+43 TO STA 1251+10 (POE)
SOUTHBOUND SERVICE DRIVE, STA 1216+14 TO STA 1235+25 AND STA 1238+50 TO STA 1247+25 (POE) (REVERSED)

- * NOTE:
1. NB SERVICE DRIVE, STA 1241+23 TO STA 1243+86, LEFT LANE TAPERS FROM 9' TO 15' AND CROSS SECTION WIDTH VARIES FROM 24' TO 30'.
 2. SB SERVICE DRIVE, STA 1238+50 TO STA 1242+00, RIGHT LANE TAPERS FROM 1' TO 15' AND CROSS SECTION WIDTH VARIES FROM 16' TO 30'.

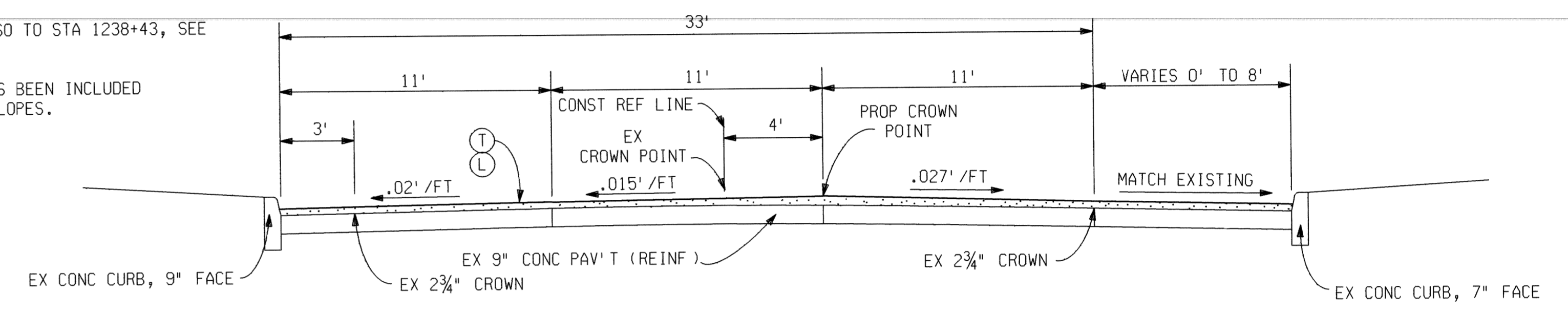

TYPICAL SB RAMP TRANSITION SECTION

TO APPLY: SOUTHBOUND SERVICE DRIVE, STA 1235+25 TO STA 1238+50

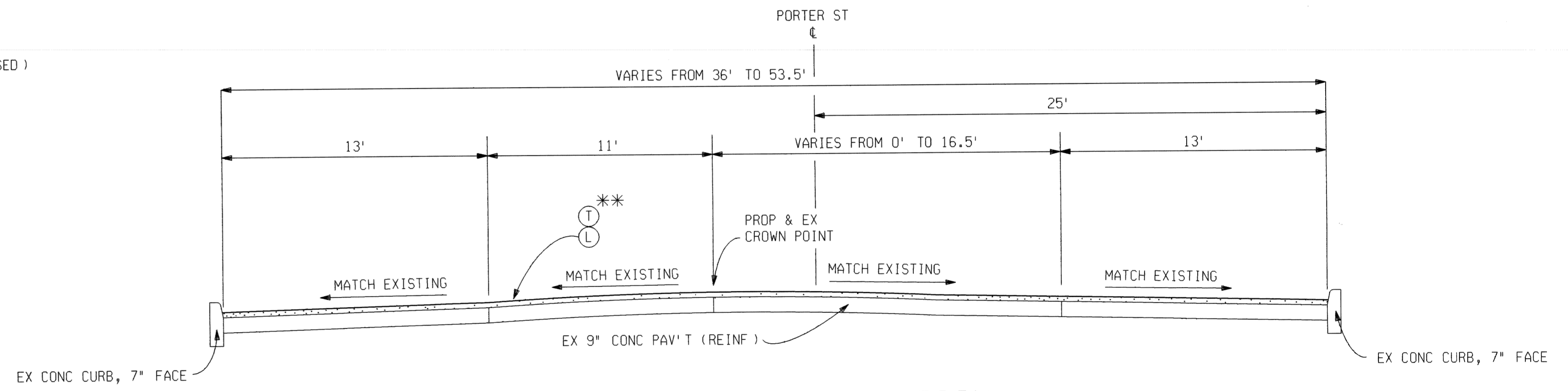

PORTER STREET SECTION

TO APPLY: PORTER STREET FROM STRUCTURE OVER I-75 TO 21ST STREET STA 11+76 TO STA 15-51

** NOTE: MILL EXISTING SURFACE TO A DEPTH OF 3" FROM STA 12+90 TO STA 15+51, AND PLACE 330#/SYD BIT MIX 3C BEFORE PLACING L AND T COURSES.

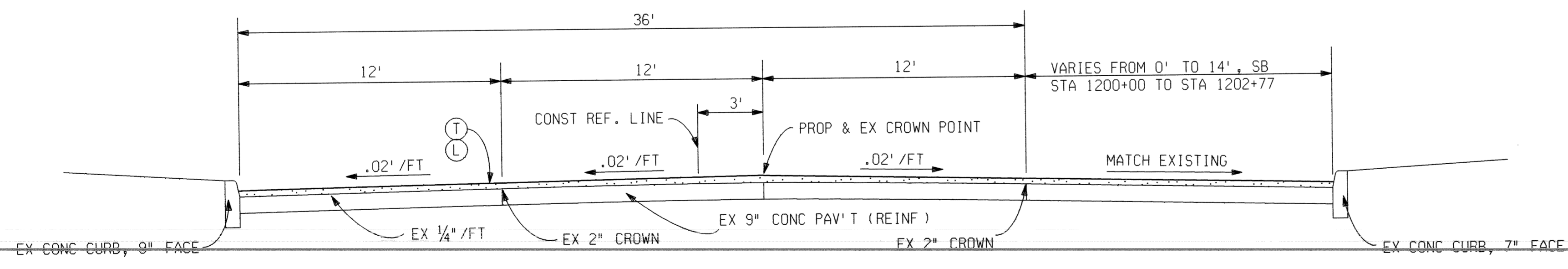

TYPICAL 36' SERVICE ROAD SECTION

TO APPLY: SOUTHBOUND SERVICE DRIVE, STA 1195+70 (POB) TO 1202+77

BITUMINOUS APPLICATION ESTIMATE

IDENT NO	ITEM	POUNDS (PER SYD)	ASPHALT PENETRATION	REMARKS
T	BITUMINOUS MIXTURE NO 4C - MODIFIED	160	85-100	
L	BITUMINOUS MIXTURE NO 3C	170	85-100	
	BITUMINOUS BOND COAT	0-0.10 GAL		FOR INFORMATION ONLY

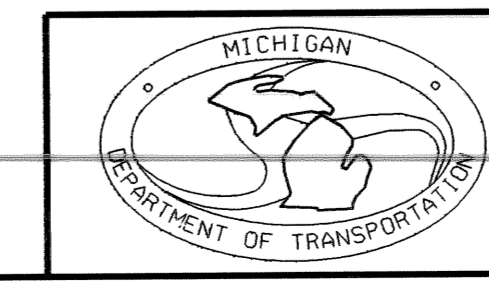

TYPICAL CROSS SECTIONS					
DATE	SCALE	CONT. SEC.	JOB NO.	DESIGN UNIT	SHEET NO.
06/23/95	1" = NONE	82194	39004 A	ERBEN	R.O.W CONST. 2

FINAL R.O.W.			
AUTH	DATE	NO.	REVISION

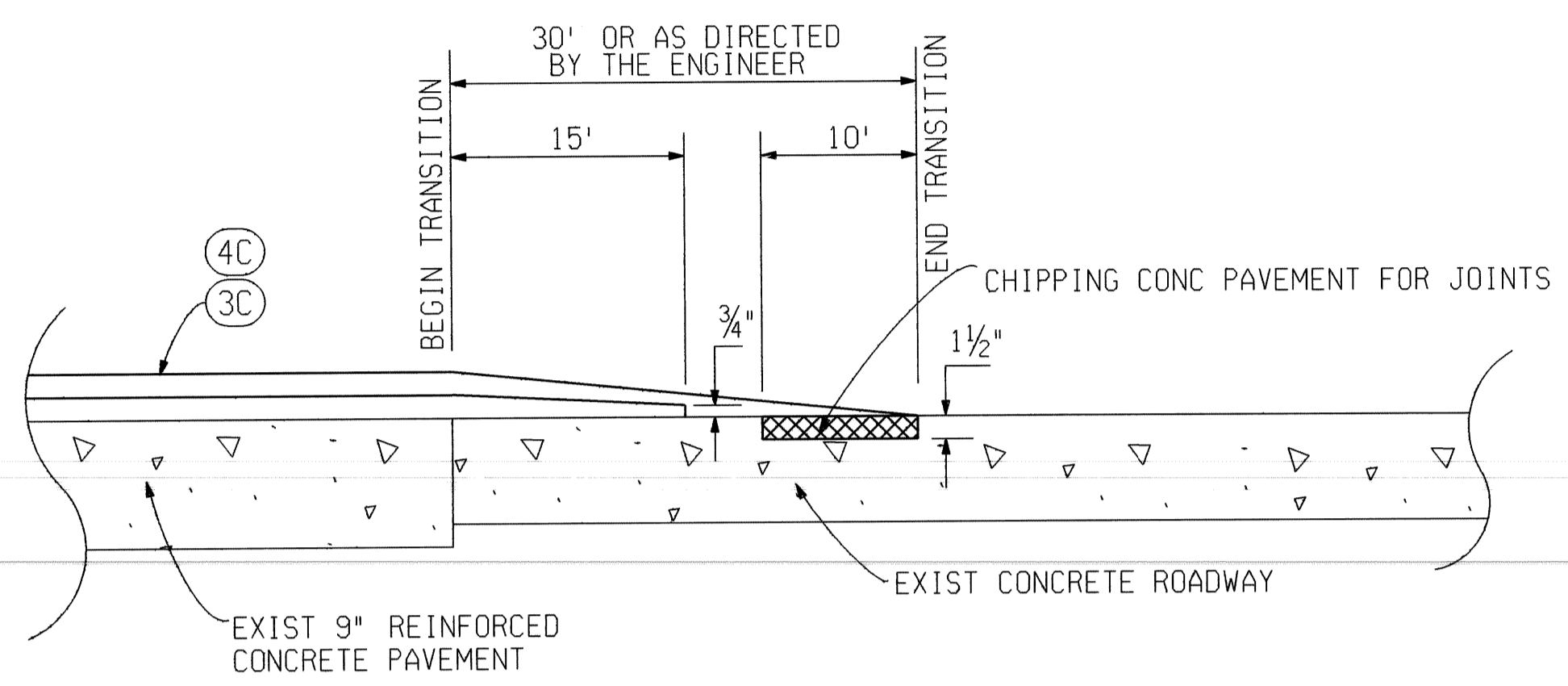

CONCRETE SIDE STREETS

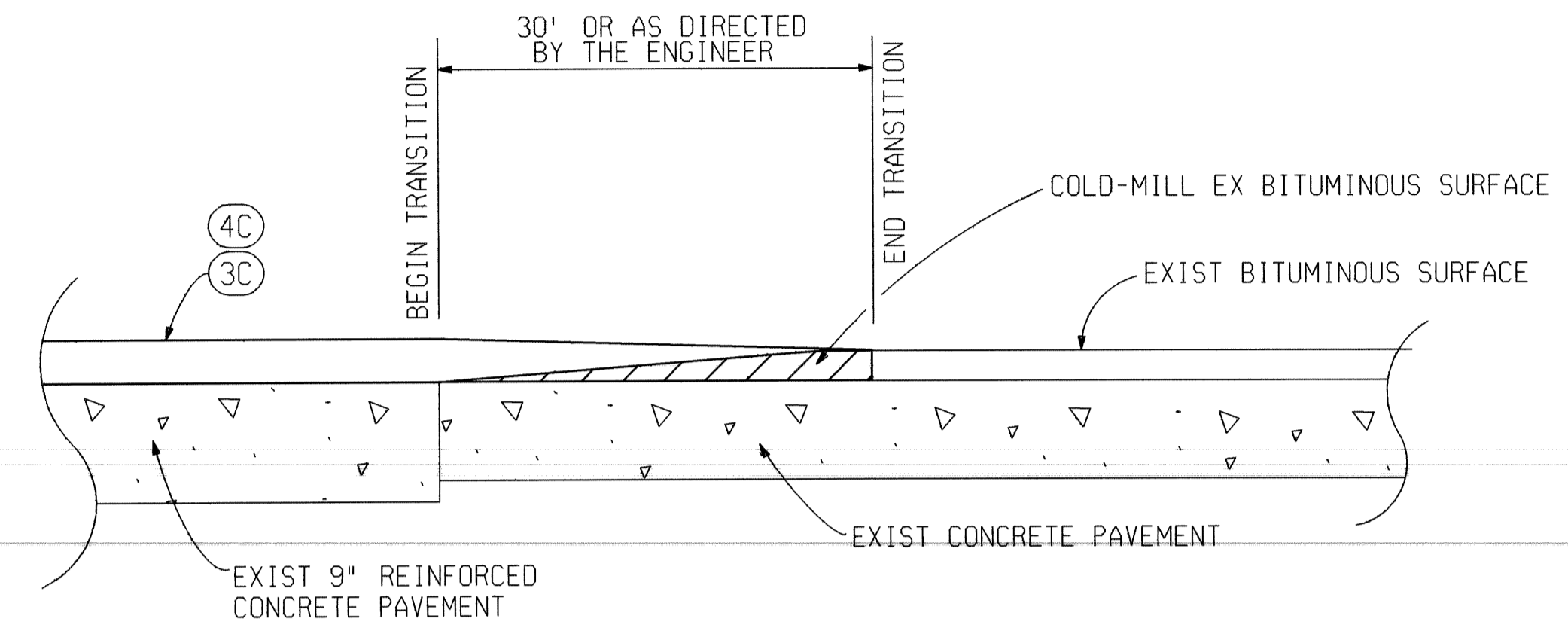

BITUMINOUS SIDE STREETS

BITUMINOUS SURFACE TRANSITION AT EXISTING SIDE STREETS

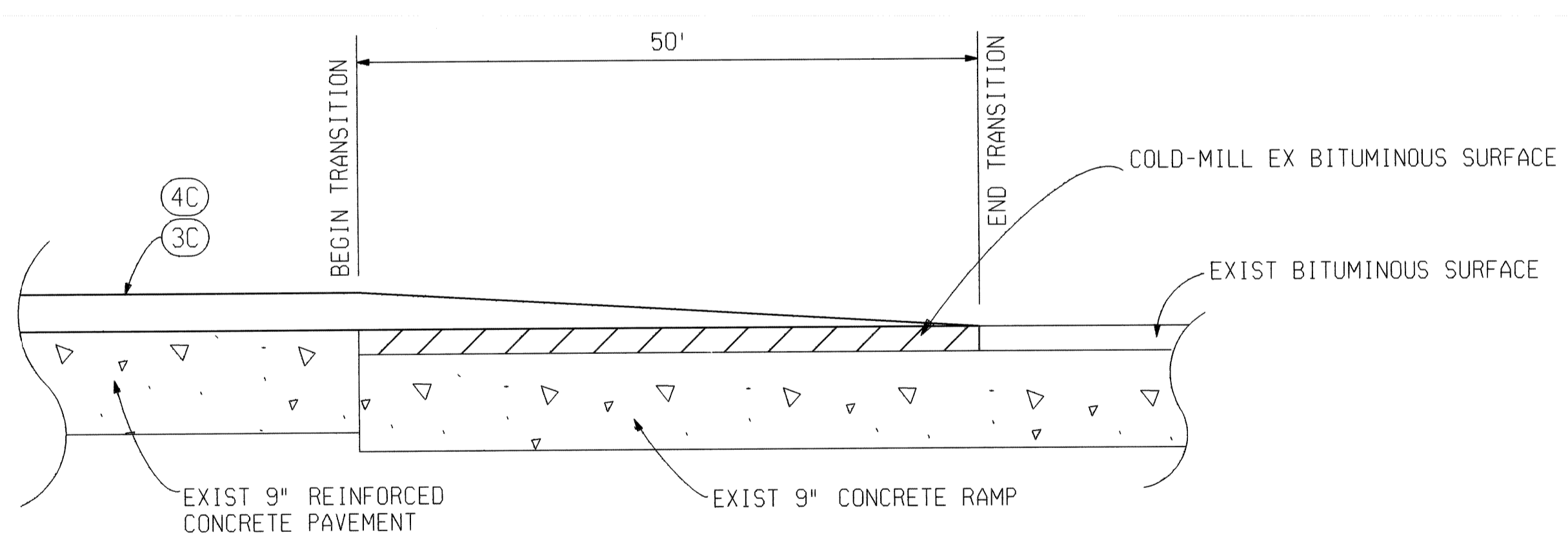

BITUMINOUS SURFACE TRANSITION AT EXISTING FREEWAY RAMP

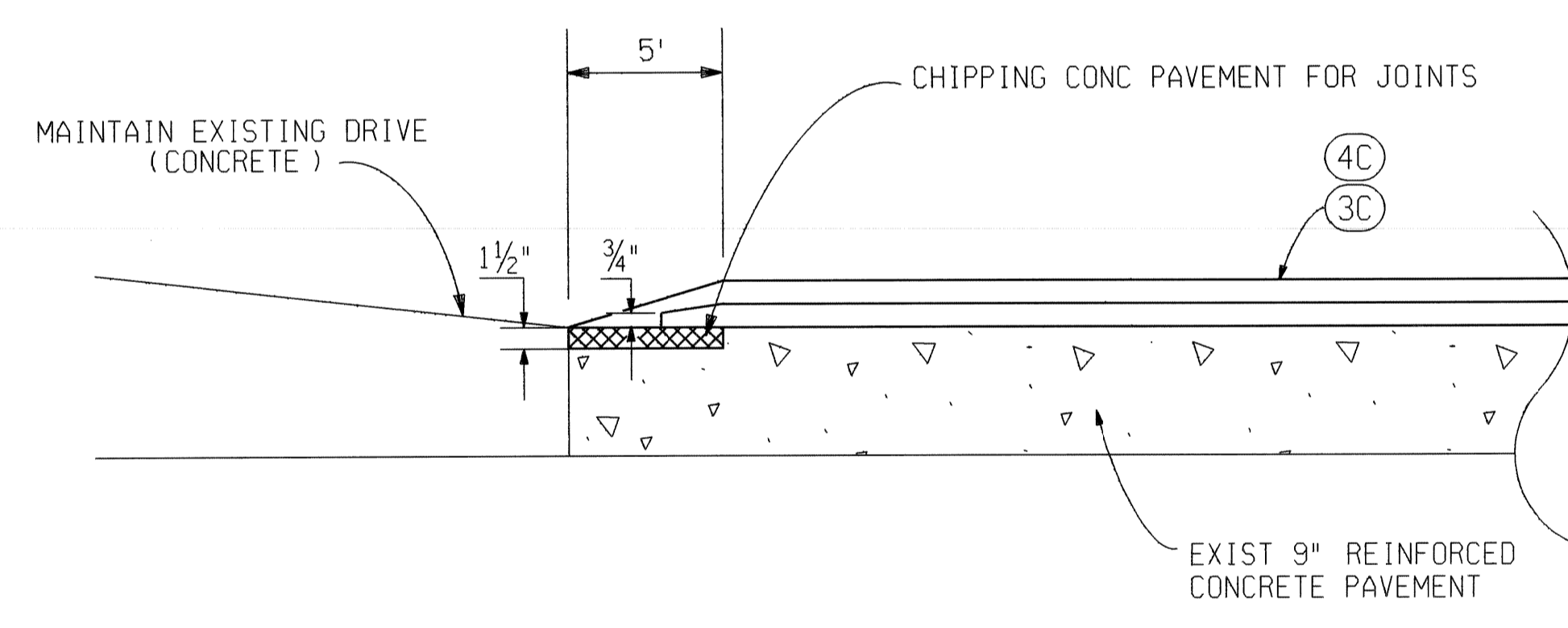

DETAIL AT AMBASSADOR BRIDGE PLAZA DRIVE

26 27

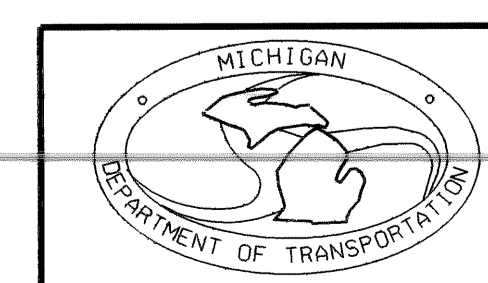

DETAIL SHEET					
DATE	SCALE	CONT. SEC.	JOB NO.	DESIGN UNIT	SHEET NO.
06/23/95	1" = NONE	82194	39004 A	ERBEN	R.O.W CONST. 3

JOB NO. 39004 A
 CONTROL SECTION 82194
 SHEET NO. 4

ENGINEERING REPORT NO	ENVIRON IMPACT STMT	YEAR
METHOD OF SURVEY		YEAR
SURVEY ORDER	SURVEY CHIEF	YEAR
AERIAL SURVEY NO		YEAR
HORIZ DATUM	VERT DATUM	
ROAD DESIGN INITIATED	COMPLETED	
PRELIMINARY PLANS BY	FINAL PLANS BY	
FIELD INSPECTION (GI) BY		DATE
PLANS-IN-HAND BY (FHWA)	AND (MDOT)	DATE

GENERAL PLAN NOTES

UNDERGROUND UTILITIES

FOR PROTECTION OF UNDERGROUND UTILITIES AND IN CONFORMANCE WITH PUBLIC ACT 53, 1974, THE CONTRACTOR SHALL DIAL 1-800-482-7171 A MINIMUM OF THREE FULL WORKING DAYS, EXCLUDING SATURDAYS, SUNDAYS, AND HOLIDAYS PRIOR TO BEGINNING EACH EXCAVATION IN AREAS WHERE PUBLIC UTILITIES HAVE NOT BEEN PREVIOUSLY LOCATED. MEMBERS WILL BE ROUTINELY NOTIFIED. THIS DOES NOT RELIEVE THE CONTRACTOR OF THE RESPONSIBILITY OF NOTIFYING UTILITY OWNERS WHO MAY NOT BE A PART OF THE "MISS DIG" ALERT SYSTEM.

OLD PLANS

THE FOLLOWING PLANS WERE REFERRED TO IN THE DESIGN OF THIS PROJECT.
 82194J, C28
 82194J, C29
 82194K, C31
 IN ADDITION, OTHER OLD PLANS THAT PREDATE THIS PROJECT MAY BE AVAILABLE. THESE PLANS MAY BE REVIEWED IN THE LANSING DESIGN OFFICE DURING NORMAL WORKING HOURS.

STATIONING

STATIONING ON THIS PROJECT WAS ESTABLISHED FROM THE ORIGINAL CONSTRUCTION PLANS NOTED ABOVE.

ADJUSTING MONUMENT BOXES

IT IS THE INTENT THAT ALL GOVERNMENT CORNERS ON THIS PROJECT BE PRESERVED AND THAT, WHERE NECESSARY, MONUMENT BOXES BE PLACED OR ADJUSTED, WHETHER SHOWN OR NOT.

SIGNS

ANY EXISTING SIGNS WHICH ARE TO REMAIN IN PLACE AND REQUIRE RELOCATION DUE TO CONSTRUCTION OPERATIONS SHALL BE SALVAGED AND RESET BY THE CONTRACTOR AT LOCATIONS DESIGNATED BY THE ENGINEER. THIS WORK WILL BE CONSIDERED INCLUDED IN PAYMENT FOR OTHER CONTRACT ITEMS.

SIDEWALK RAMPS

ALL PROPOSED SIDEWALK RAMPS SHALL BE CONSTRUCTED WITH 7" REINFORCED CONCRETE.

CURE TIME FOR PAVEMENT PATCHES

TO PROVIDE SUFFICIENT BONDING BETWEEN THE PROPOSED ASPHALT AND THE PROPOSED CONCRETE PATCHES, THE CONCRETE SHALL BE ALLOWED TO CURE ONE WEEK PRIOR TO RESURFACING, OR AS DIRECTED BY THE ENGINEER.

PUBLIC UTILITIES

THE EXISTING UTILITIES LISTED BELOW AND SHOWN ON THESE PLANS REPRESENT THE BEST INFORMATION AVAILABLE. THIS INFORMATION DOES NOT RELIEVE THE CONTRACTOR OF THE RESPONSIBILITY TO BE SATISFIED AS TO IT'S ACCURACY AND THE LOCATION OF EXISTING UTILITIES.

NAME OF OWNER	KIND OF UTILITY
DETROIT EDISON COMPANY ATTN: GLENN SPENCE 2000 SECOND AVENUE - RM. 345WCB DETROIT, MI 48226 PHONE: (313) 237-6450	ELECTRIC
MICHIGAN CONSOLIDATED GAS CO. ATTN: DAVID WIATER 3200 HOBSON DETROIT, MI 48201 PHONE: (313) 577-7143	GAS
BARDEN CABLEVISION ATTN: EDMUND P. LANE 12775 LYNDON DETROIT, MI 48227 PHONE: (313) 934-2600	CABLE TV
AMERITECH ATTN: CHARLES SHAND 54 N. MILL STREET PONTIAC, MI 48342 PHONE: (810) 456-0860	TELEPHONE
DETROIT PUBLIC LIGHTING DEPT. ATTN: MARK PETTY 9449 GRINNEL AVENUE DETROIT, MI 48213 PHONE: (313) 267-7205	STREET LIGHTING
DETROIT WATER AND SEWERAGE DEPARTMENT ATTN: MOHAMMAD GILL, ACTING HEAD ENGINEER 735 RANDOLPH STREET DETROIT, MI 48226 PHONE: (313) 224-4735	WATER & SEWER
CITY OF DETROIT DEPARTMENT OF PUBLIC WORKS ATTN: HANI DICKOW STREETS AND TRAFFIC DEPARTMENT 1301 EAST WARREN DETROIT, MI 48207	TRAFFIC SIGNALS

NOTE:

ADJUSTMENTS REQUIRED TO STRUCTURES OWNED BY AMERITECH WILL BE MADE BY AMERITECH PERSONNEL. THE CONTRACTOR SHALL CALL CLIFF KENNEDY AT (313) 523-0470 AT LEAST TWO WORKING DAYS IN ADVANCE.

ADJUSTMENTS REQUIRED TO STRUCTURES OWNED BY DETROIT EDISON WILL BE MADE BY DETROIT EDISON PERSONNEL. THE CONTRACTOR SHALL CALL BILL LOGAN AT (313) 237-9501 OR GLENN PEARSON AT (313) 237-9693, AT LEAST FIVE WORKING DAYS IN ADVANCE.

NOTES APPLYING TO STANDARD PLANS

WHERE THE FOLLOWING ITEMS ARE CALLED FOR ON PLANS, THEY ARE TO BE CONSTRUCTED ACCORDING TO THE STANDARD PLAN GIVEN BELOW OPPOSITE EACH ITEM UNLESS OTHERWISE INDICATED.

COVER A	I-7B
COVER K	I-15C
SIDEWALK RAMP DETAILS	II-28G
DRIVEWAY OPENINGS & APPROACHES, AND CONCRETE SIDEWALKS	II-29E
CONCRETE CURB AND CONCRETE CURB AND GUTTER	II-30D
TRANSVERSE PAVEMENT JOINTS	II-39K
LONGITUDINAL PAVEMENT JOINTS	II-41J
LOCATION OF TRANSVERSE JOINTS IN CONCRETE PAVEMENT	II-43D
CONCRETE PAVEMENT REPAIR	II-44H
CONVENTIONAL PAVEMENT REINFORCEMENT	II-45G
LIGHTED ARROWS AND BARRICADES	VI-125H

QUANTITY NOTES

PROPOSED AREA OF WORK

THIS PROJECT ADDRESSES WORK ON THE NORTHBOUND AND SOUTHBOUND I-75 SERVICE DRIVES FROM SOUTH OF CLARK STREET TO VERNOR HIGHWAY, AND FOR PORTER STREET BETWEEN THE STRUCTURE OVER I-75 AND 21ST STREET.

REPLACEMENT OF CONCRETE PAVEMENT

REPLACEMENT OF PAVEMENT 50' OR LESS IN LENGTH SHALL BE PAID FOR AS CONCRETE PAVEMENT REPAIR - REINFORCED 10". REPLACEMENT OF PAVEMENT GREATER THAN 50' IN LENGTH SHALL BE PAID FOR AS MISCELLANEOUS CONCRETE PAVEMENT - REINFORCED 9".

REMOVAL OF EXISTING INTEGRAL CURB

WHERE EXISTING INTEGRALLY POURED CURB IS TO BE REPLACED, THE PAVEMENT SHALL BE SAWCUT FULL DEPTH AT THE FACE OF THE EXISTING CURB AND THE CURB REMOVED. THIS WORK SHALL BE CONSIDERED INCLUDED IN PAYMENT FOR REMOVING CURB.

REMOVING EXISTING BITUMINOUS PATCHES

EXISTING DETERIORATED BITUMINOUS PATCHES SHALL BE REMOVED WHERE DIRECTED BY THE ENGINEER PRIOR TO RESURFACING AND THE RESULTING CAVITY FILLED WITH NEW BITUMINOUS MATERIAL. THIS WORK WILL BE PAID FOR AS REMOVING BITUMINOUS SURFACE AND HAND PATCHING.

EXISTING BY: DENNIS KELLEY / DT10 DATE: 05-03-95
 PROPOSED BY: DATE:
 LAST CORRECTION BY: KELLEY, D./DT10 DATE: 06-22-95
 FILE NAME: NOTES.DGN
 1 2

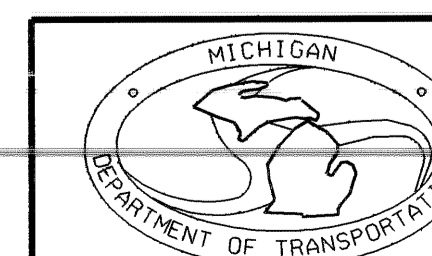

NOTE SHEET

DATE	CONT. SEC.	JOB NO.	DESIGN UNIT	SHEET NO.
06/23/95	82194	39004 A	ERBEN	R.O.W CONST. 4

FILE NAME: legend.dgn 1 2 3 4 5 6 7 8 9 10 11 12 13 14 15 16 17 18 19 20 21 22 23 24 25 26 27 28 29 30 31 32 33 34 35 36 37 38 39 40 41 42 43 44 45 46 47 48 49 50 51 52 53 54 55 56 57 58 59 60 61 62 63

WATER & DRAINAGE SYMBOLS

- EXISTING CATCH BASIN
- PROPOSED CATCH BASIN
- EXISTING MANHOLE
- PROPOSED MANHOLE
- EXISTING CULVERT END SECTION
- PROPOSED CULVERT END SECTION
- EXISTING HEADWALL
- PROPOSED HEADWALL
- WATER SHUTOFF (Service Valve)
- GATE VALVE
- GATEWELL
- WATER METER
- WATER MANHOLE
- EXISTING FIRE HYDRANT
- PROPOSED FIRE HYDRANT

- ADJ-HYD ADJUST FIRE HYDRANT
- ADJ ADJUST DRAINAGE STRUCTURE
- ADJ-K ADJUST DRAINAGE STRUCTURE W/COVER
- ADJ-B/O ADJUST DRAINAGE STRUCTURE BY OTHERS
- REC RECONSTRUCT DRAINAGE STRUCTURE
- REC-K RECONSTRUCT DRAINAGE STRUCTURE W/COVER
- REL-B/O RELOCATE - BY OTHERS
- SR-1 SIDEWALK RAMP TYPE
- CHECK DAM (PROFILES)
- DIKE (PROFILES)
- W.T. WATER TABLE (PROFILES)
- GUARD POST
- WATER WELL

REAL ESTATE SYMBOLS

- PROPERTY OWNERSHIP ARROW
- CONTIGUOUS PROPERTY SYMBOL

PARCEL NUMBER BOX

PARCEL LINES

UTILITIES SYMBOLS

- POWER POLE
- TELEPHONE POLE
- GUY POLE
- LIGHT POLE
- POWER LIGHT POLE
- TELEPHONE MANHOLE
- POWER TOWER
- GAS VALVE
- WALK/NO-WALK
- DEADMAN FOR GUYWIRE
- RAILROAD SIGNAL
- ELECTRICAL MANHOLE
- ELECTRICAL HANDHOLE
- TELEPHONE PEDESTAL/RISER

MISCELLANEOUS SYMBOLS

- RIPRAP
- SIGN
- STUMP
- SWAMP
- DECIDUOUS TREE
- EVERGREEN TREE
- MAIL BOX
- QUARTER CORNER
- SECTION CORNER
- HALF QUARTER SECTION
- TEST HOLE NO.
- BEAM G. R. RUN NUMBER (EXISTING)
- BEAM G. R. RUN NUMBER (PROPOSED)

USED WITH UNDERGROUND GAS & ELECTRICAL LINES

USED WITH FIBER OPTICS LINES

PROPOSED CULVERT/SEWER

EXISTING CULVERT/SEWER

UTILITY PATTERNS

- ELECTRICAL LINE
- GAS LINE
- OIL LINE
- TELEPHONE LINE
- WATER LINE
- CABLE TV
- FIBER OPTICS
- POWER TRANSMISSION LINE

R.O.W. PATTERNS

- EX. LIMITED ACCESS R.O.W.
- EXISTING R.O.W.
- PROP LIMITED ACCESS R.O.W.
- PROP FREE ACCESS R.O.W.
- SECTION LINE

TOPO PATTERNS

- HEDGE LINE
- TREE LINE
- EXISTING FENCE
- PROPOSED FENCE
- EXISTING GUARD RAIL
- PROPOSED GUARD RAIL
- DRAINAGE CRS/EDGE OF WATER
- WETLANDS AREA
- ABANDON ANY UTILITY
- CITY LIMITS
- RAILROAD
- SOUND ABATEMENT WALL
- CONCRETE MEDIAN BARRIER
- SLOPE STAKE LINE

DRIVE/APPROACH LEGEND

- CONCRETE
- BITUMINOUS
- AGGREGATE

REMOVAL LEGEND

- REMOVING BITUMINOUS
- REMOVING SIDEWALK
- REMOVING PAVEMENT
- COLD-MILLING
- REMOVING CURB & GUTTER
- REMOVING
- ABANDONING
- SAVE
- BULKHEAD
- CLEARING

NOTE: SYMBOLS ARE ENLARGED FOR CLARITY

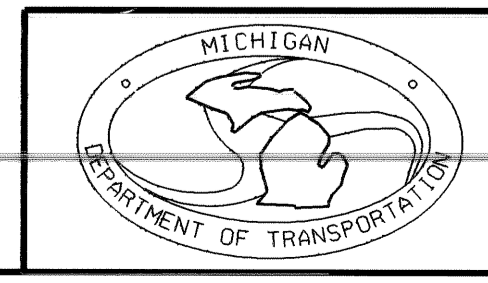

LEGEND SHEET				
DATE	SCALE	CONT. SEC.	JOB NO.	DESIGN UNIT
06/23/95	NTS	82194	39004 A	ERBEN
SHEET NO.				SHEET NO.
R.O.W CONST.				5

EXISTING BY: DENNIS KELLEY / DT10 DATE: 04-20-95
 PROPOSED BY: KELLEY, D. / DT10 DATE: 06-23-95
 LAST CORRECTION BY: KELLEY, D. / DT10 DATE: 06-23-95

FINAL R.O.W.		
AUTH	DATE	REVISION

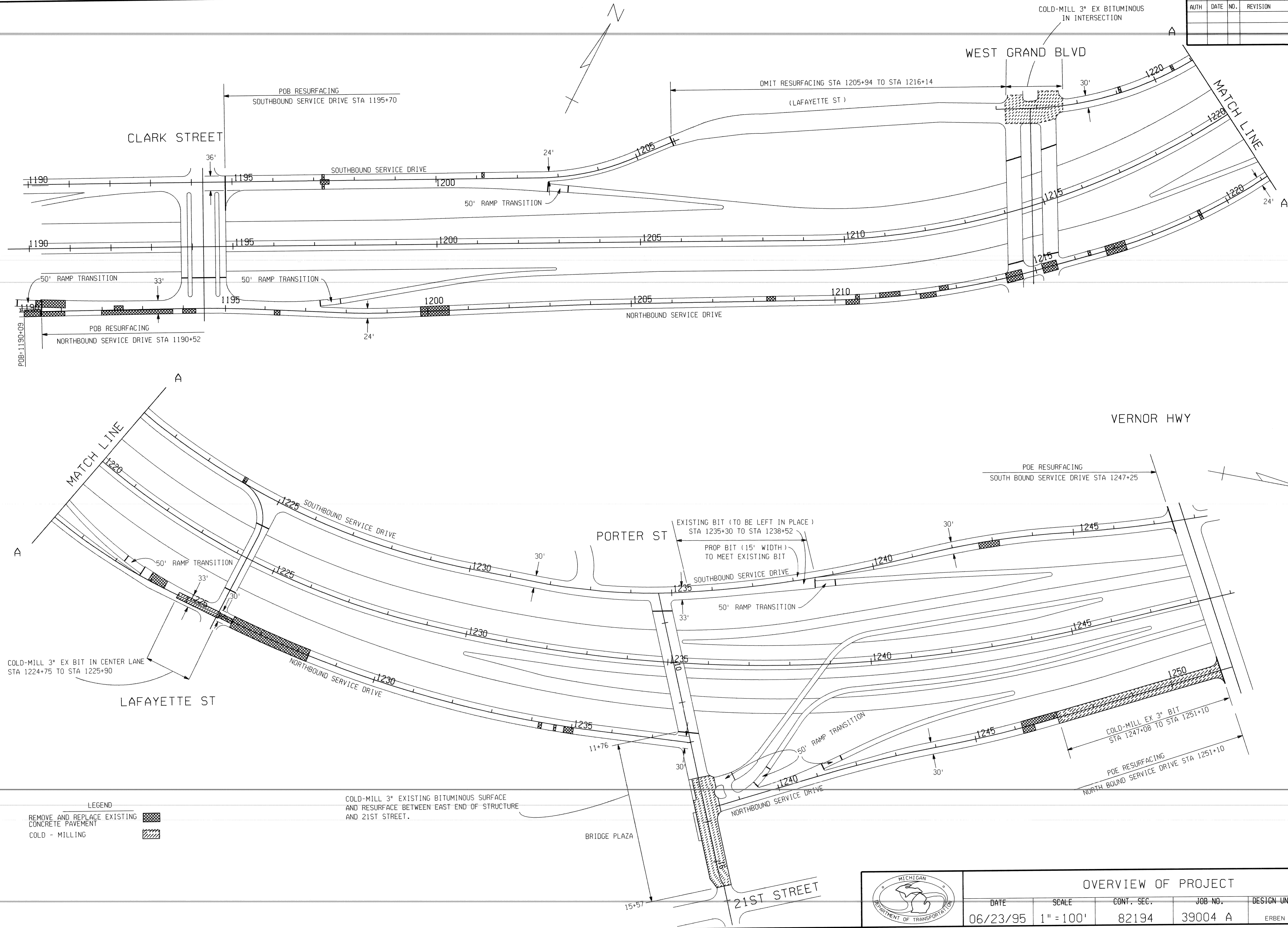

LEGEND
 REMOVE AND REPLACE EXISTING CONCRETE PAVEMENT [Hatched Box]
 COLD - MILLING [Diagonal Lines Box]

COLD-MILL 3" EXISTING BITUMINOUS SURFACE AND RESURFACE BETWEEN EAST END OF STRUCTURE AND 21ST STREET.

FILE NAME: plan.dgn 11
 1 2

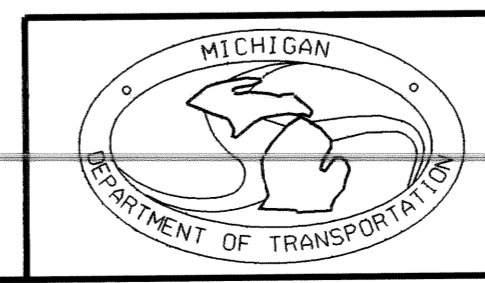

OVERVIEW OF PROJECT					
DATE	SCALE	CONT. SEC.	JOB NO.	DESIGN UNIT	SHEET NO.
06/23/95	1" = 100'	82194	39004 A	ERBEN	R.O.W CONST. 6

ITEMS FOR SURFACE REPAIRS

- 5603 LFT REPAIRING PAVEMENT JOINTS AND CRACKS, DETAIL 7
- 353 LFT REPAIRING PAVEMENT JOINTS AND CRACKS, DETAIL 8
- 1550 LFT LONGITUDINAL JOINT REPAIR
- 362 TONS HAND PATCHING
- 219 SYD REMOVING BIT PATCHES

ITEMS FOR RESURFACING

- 1 LSUM CLEANING PAVEMENT
- 5392 SYD COLD-MILLING BITUMINOUS SURFACE
- 2467 TONS BITUMINOUS MIXTURE 4C - MODIFIED
- 2939 TONS BITUMINOUS MIXTURE 3C
- 455 TONS BITUMINOUS APPROACH
- 1267 SYD CHIPPING CONCRETE PAVEMENT FOR JOINTS
- 203 EACH ADJUSTING DRAINAGE STRUCTURE COVER, CASE 1
- 72 LFT RECONSTRUCTING DRAINAGE STRUCTURE, CASE 1
- 14981 LBS DRAINAGE STRUCTURE COVER
- 3 EACH ADJUSTING WATER SHUTOFF

ITEMS FOR SEDIMENTATION CONTROL

- 4 EACH CURB AND GUTTER INLET FILTER

MISCELLANEOUS QUANTITIES

- 1 LSUM MOBILIZATION
- 5860 TONS QUALITY CONTROL TESTING
- 1 BMT BITUMINOUS QUALITY INITIATIVE
- 1 EACH ADJUSTING MONUMENT BOX

ITEMS FOR SUBGRADE MODIFICATION

- 50 CYD SUBGRADE UNDERCUTTING, TYPE II
- 100 LFT SUBGRADE UNDERDRAIN, 6"
- 4 EACH SEWER TAP, 6"

ITEMS FOR FULL DEPTH PAVEMENT REPAIR

- 35 EACH MOVING FROM REPAIR TO REPAIR
- 1190 SYD REMOVING PAVEMENT (REPAIR)
- 1474 SYD REMOVING PAVEMENT
- 1622 LFT INTERMEDIATE SAW CUTS
- 1190 SYD CONCRETE PAVEMENT REPAIR - REINFORCED 10"
- 1474 SYD MISCELLANEOUS CONCRETE PAVEMENT - REINFORCED 9"
- 239 LFT TIED JOINT Trg
- 691 LFT CONTRACTION JOINT Crg
- 168 LFT EXPANSION JOINT Erg
- 390 LFT CONTRACTION JOINT C2
- 12 LFT EXPANSION JOINT E2
- 9 LFT EXPANSION JOINT ESC
- 59 LFT PLANE-OF-WEAKNESS JOINT D1
- 711 EACH EPOXY ANCHORED LANE TIES
- 296 TONS CEMENT
- 18875 LBS CALCIUM CHLORIDE

ITEMS FOR SIDEWALKS, RAMPS, & DRIVEWAYS

- 1084 SYD REMOVING SIDEWALK
- 4575 SFT SIDEWALK RAMP
- 2823 SFT CONCRETE SIDEWALK, 4"
- 2358 SFT CONCRETE SIDEWALK, 6"
- 893 LFT REMOVING CURB
- 893 LFT CONCRETE CURB, DETAIL E4
- 203 EACH EPOXY ANCHORED LANE TIES
- 2 CYD CONCRETE DRIVEWAY - REINFORCED 7"
- 53 LFT CONCRETE DRIVEWAY OPENING - DETAIL M

ITEMS FOR MAINTAINING TRAFFIC

- 110 EACH BARRICADE TYPE II, LIGHTED - FURNISHED
- 100 EACH BARRICADE TYPE II, LIGHTED - OPERATED
- 14 EACH BARRICADE TYPE III, LIGHTED - FURNISHED
- 12 EACH BARRICADE TYPE III, LIGHTED - OPERATED
- 1 LSUM MINOR TRAFFIC DEVICES
- 2 EACH LIGHTED ARROW, TYPE A - FURNISHED
- 2 EACH LIGHTED ARROW, TYPE A - OPERATED
- 1 LSUM FLAG CONTROL
- 25 SFT SIGN, TYPE A TEMPORARY - FURNISHED
- 25 SFT SIGN, TYPE A TEMPORARY - OPERATED
- 1435 SFT SIGN, TYPE B TEMPORARY - FURNISHED
- 1385 SFT SIGN, TYPE B TEMPORARY - OPERATED
- 12 EACH SIGN COVER

ITEMS FOR PERMANENT PAVEMENT MARKING

- 2500 LFT INLAY COLD PLASTIC PAVEMENT MARKING, 4", WHITE
- 300 LFT INLAY COLD PLASTIC PAVEMENT MARKING, 24", STOP BAR
- 600 LFT INLAY COLD PLASTIC PAVEMENT MARKING, 6", CROSSWALK

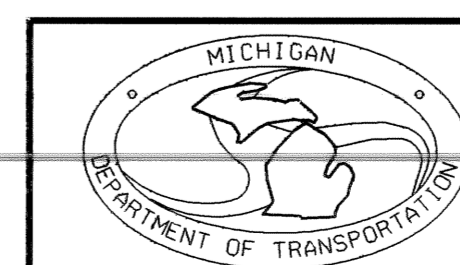

QUANTITIES

DATE	SCALE	CONT. SEC.	JOB NO.	DESIGN UNIT	SHEET NO.
06/23/95		82194	39004 A	ERBEN	7

EXISTING BY: BRIAN HIBDON DATE: 06-14-95
 PROPOSED BY: DATE:
 LAST CORRECTION BY: HIBDON, BRIAN DATE: 06-21-95

NORTHBOUND SERVICE DRIVE

FINAL R.O.W.			
AUTH	DATE	NO.	REVISION

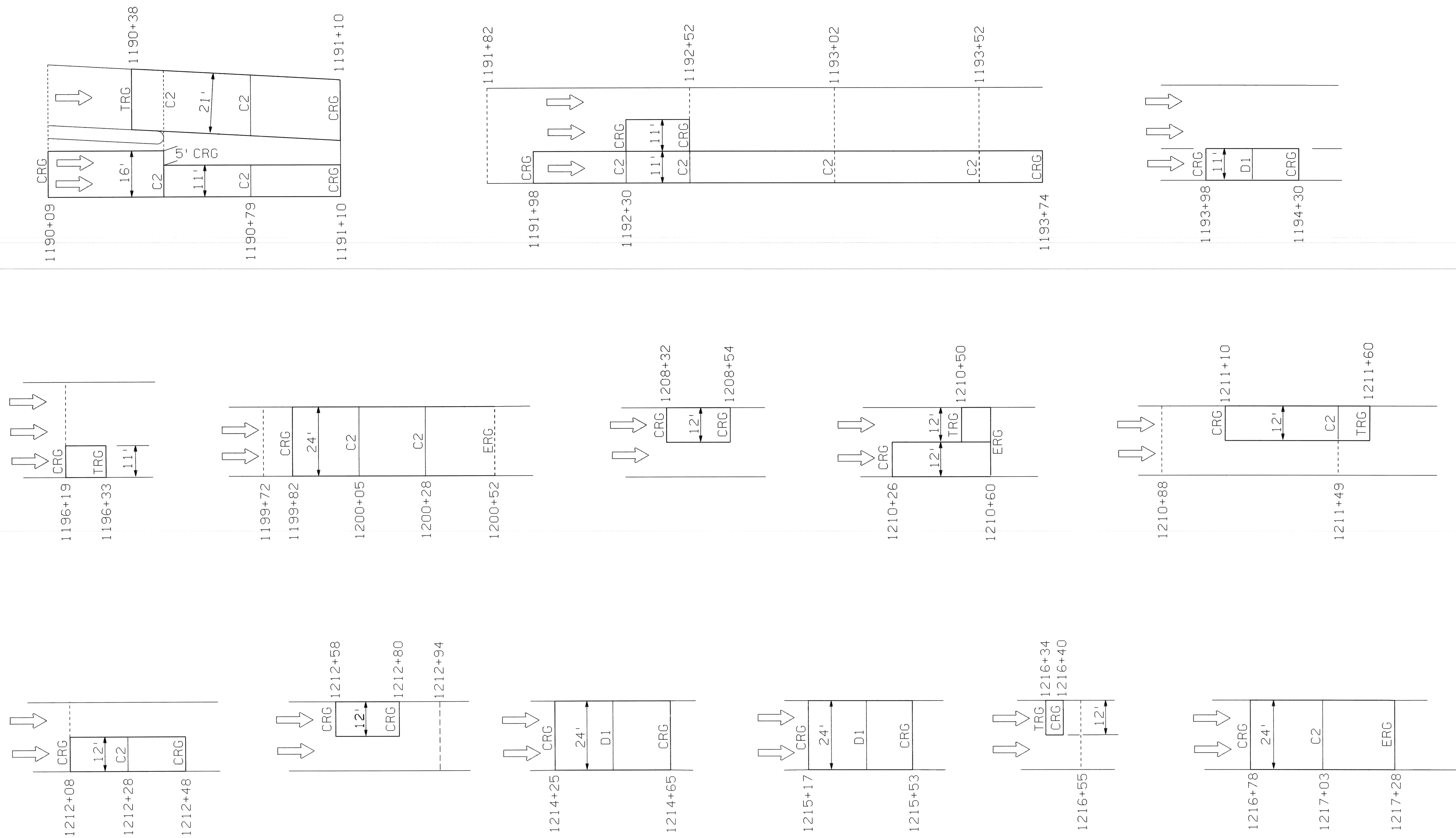

26 27

FOR JOINT TYPES, SEE STANDARD PLAN II-44H

- D1 - PLANE OF WEAKNESS JOINT, D1
- TRG - TIED JOINT, TRG
- CRG - CONTRACTION JOINT, CRG
- C2 - CONTRACTION JOINT, C2
- E2 - EXPANSION JOINT, E2
- ERG - EXPANSION JOINT, ERG
- ESC - EXPANSION JOINT, ESC

FILE NAME: DETAILS.DGN
 1, 2, 3, 4, 5, 6, 7, 8

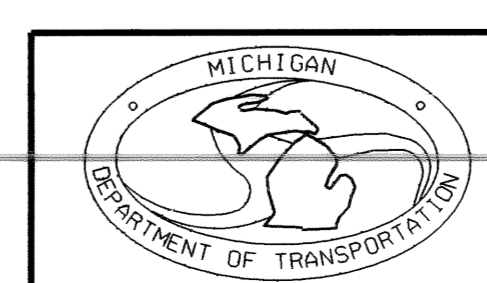

PAVEMENT PATCH LOCATIONS					
DATE	SCALE	CONT. SEC.	JOB NO.	DESIGN UNIT	SHEET NO.
06/23/95	NTS	82194	39004 A	ERBEN	R.O.W / CONST. / 8

EXISTING BY: BRIAN HIBDON DATE: 06-15-95
 PROPOSED BY: HIBDON, BRIAN DATE: 06-21-95
 LAST CORRECTION BY: HIBDON, BRIAN DATE: 06-21-95

FINAL R.O.W.		
AUTH	DATE	NO.
		REVISION

NORTHBOUND SERVICE DRIVE

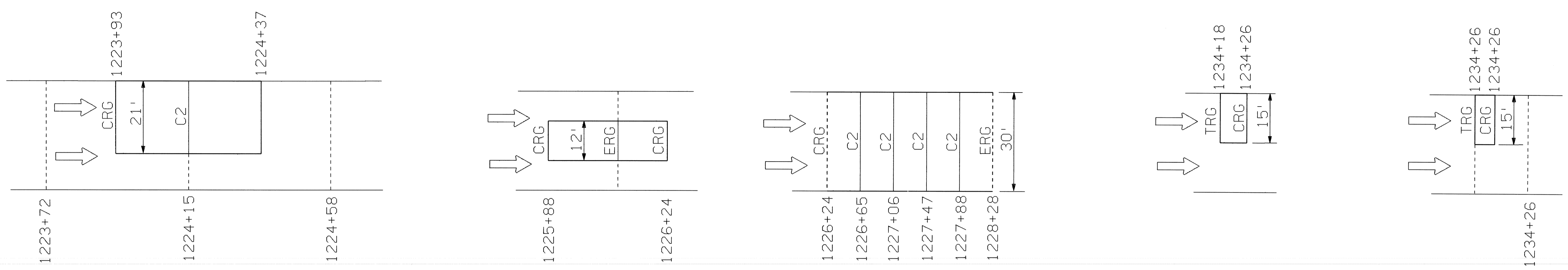

SOUTHBOUND SERVICE DRIVE

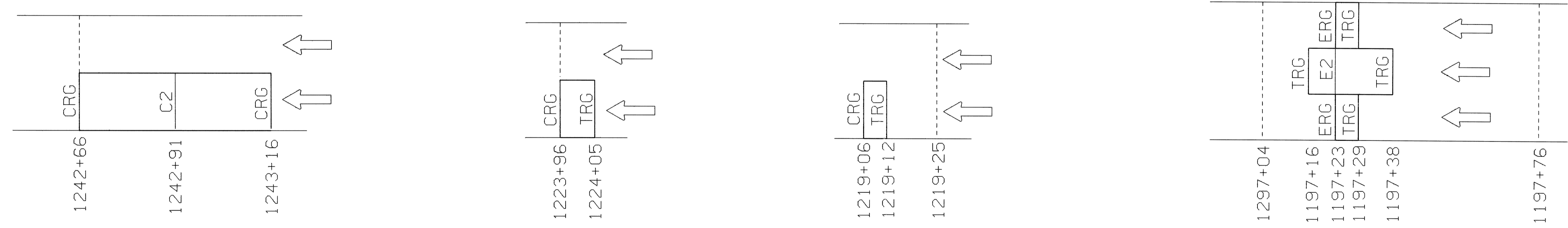

FOR JOINT TYPES, SEE STANDARD PLAN II-44H

- D1 - PLANE OF WEAKNESS JOINT, D1
- TRG - TIED JOINT, TRG
- CRG - CONTRACTION JOINT, CRG
- C2 - CONTRACTION JOINT, C2
- E2 - EXPANSION JOINT, E2
- ERG - EXPANSION JOINT, ERG
- ESC - EXPANSION JOINT, ESC

26 27

FILE NAME: DETAILS.DGN
 1 2 3 4 5 6 7 8

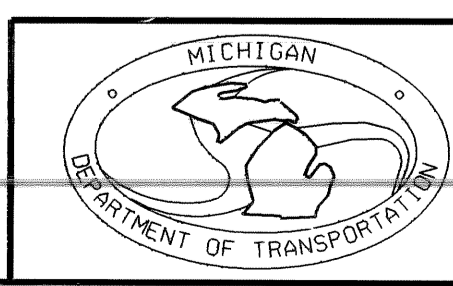

PAVEMENT PATCH LOCATIONS					
DATE	SCALE	CONT. SEC.	JOB NO.	DESIGN UNIT	SHEET NO.
06/23/95	NTS	82194	39004 A	ERBEN	R.O.W. CONST. 9

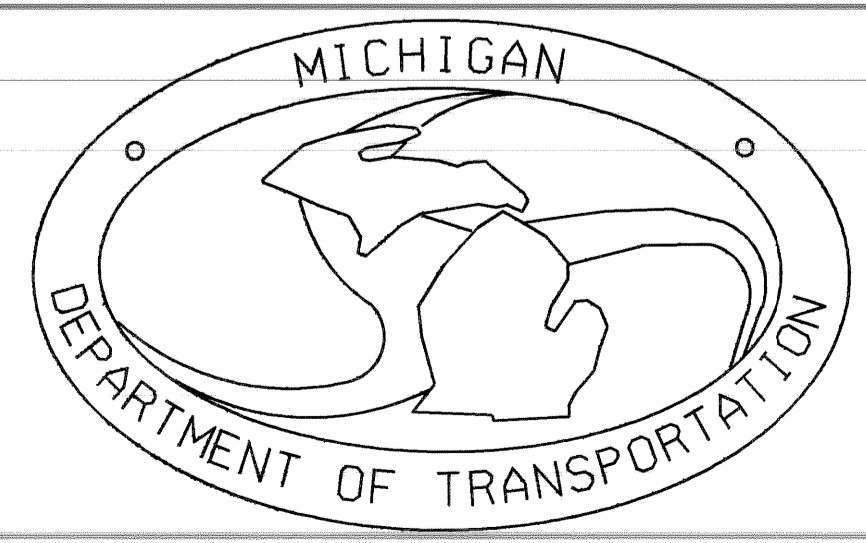
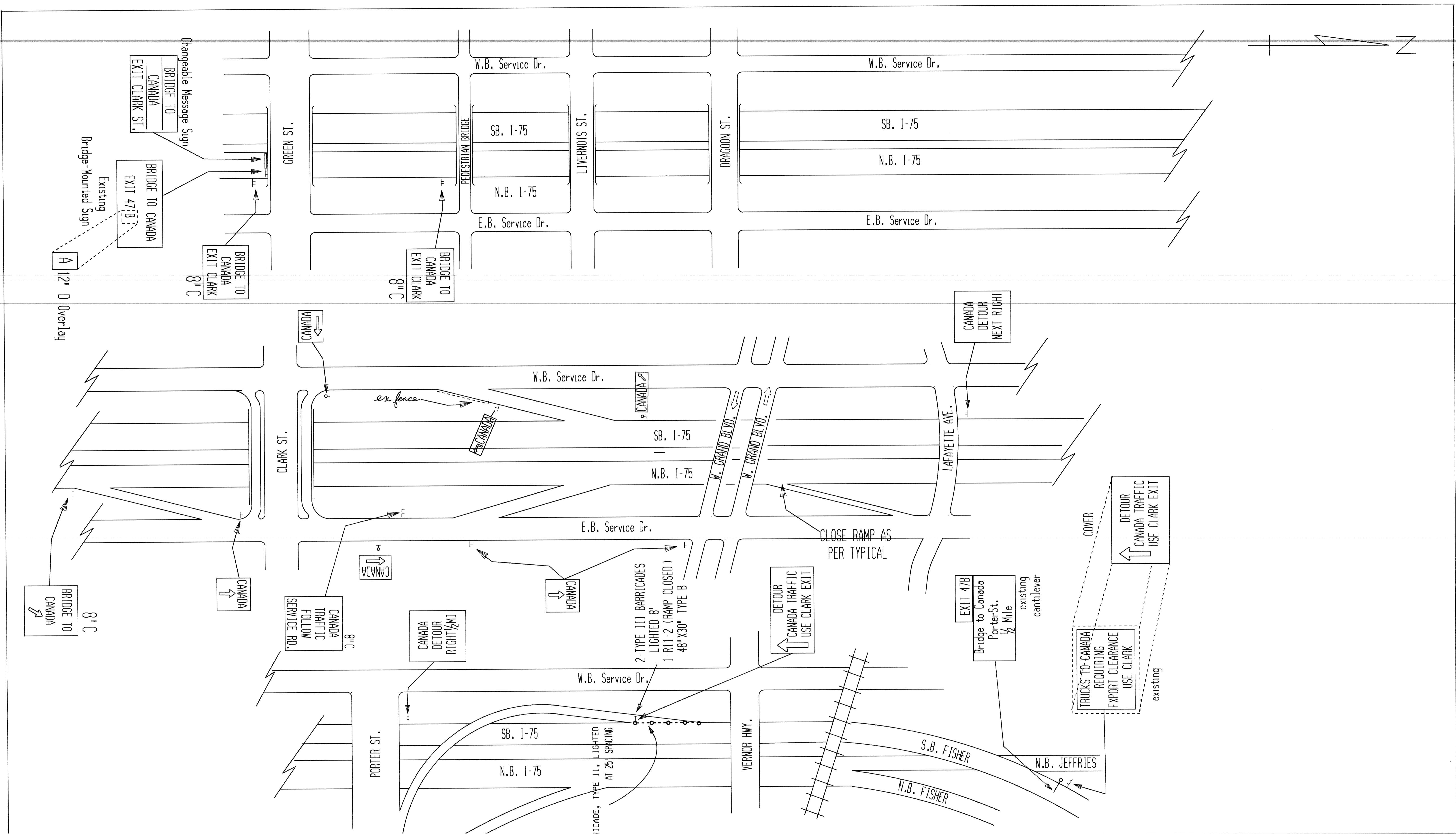

S.B. I-75 EXIT TO PORTER CLOSED

DATE
6 / 23 / 95

SCALE
NONE

CONT. SEC.
82194

SHEET NO.
10

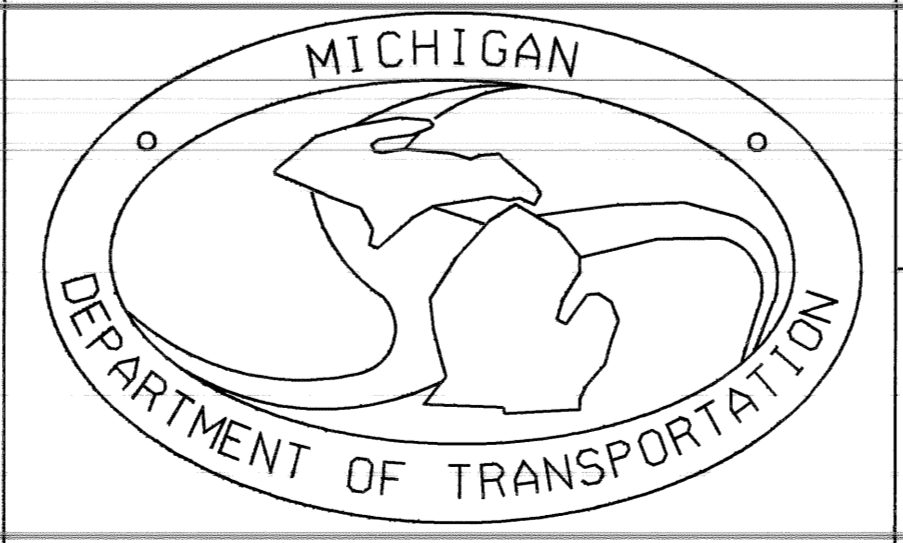
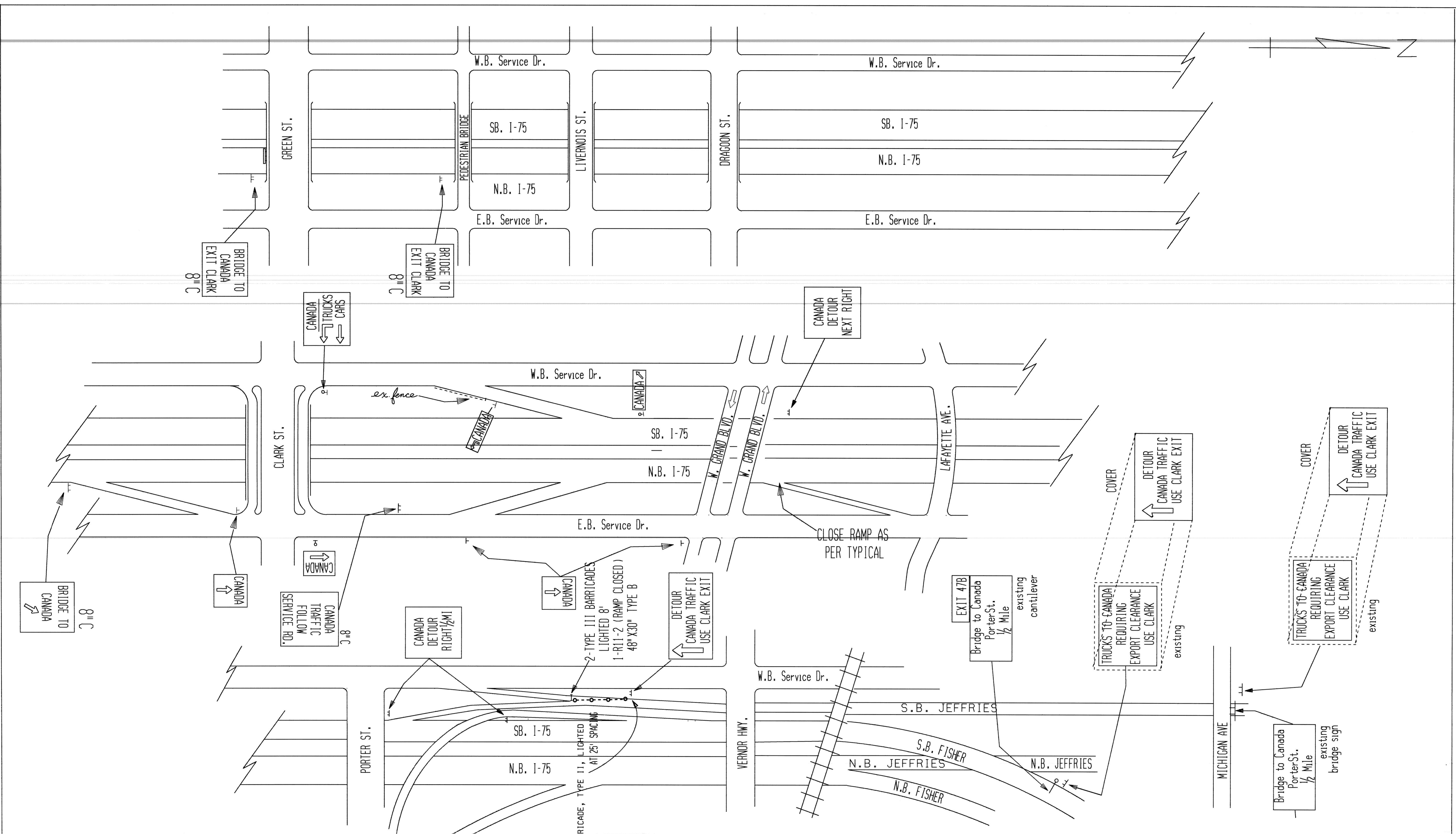

S.B. I-96 EXIT TO PORTER CLOSED

DATE 6 / 23 / 95	SCALE NONE	CONT. SEC. 82194	SHEET NO. 11
---------------------	---------------	---------------------	-----------------

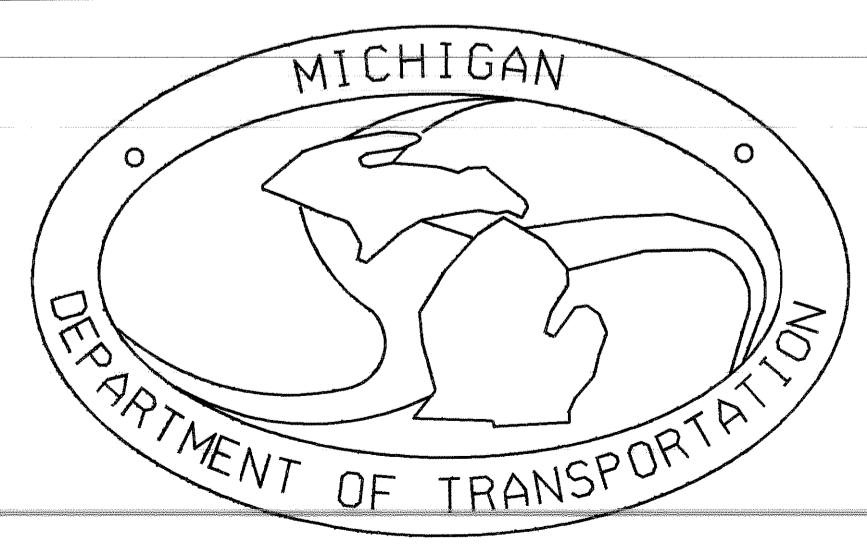
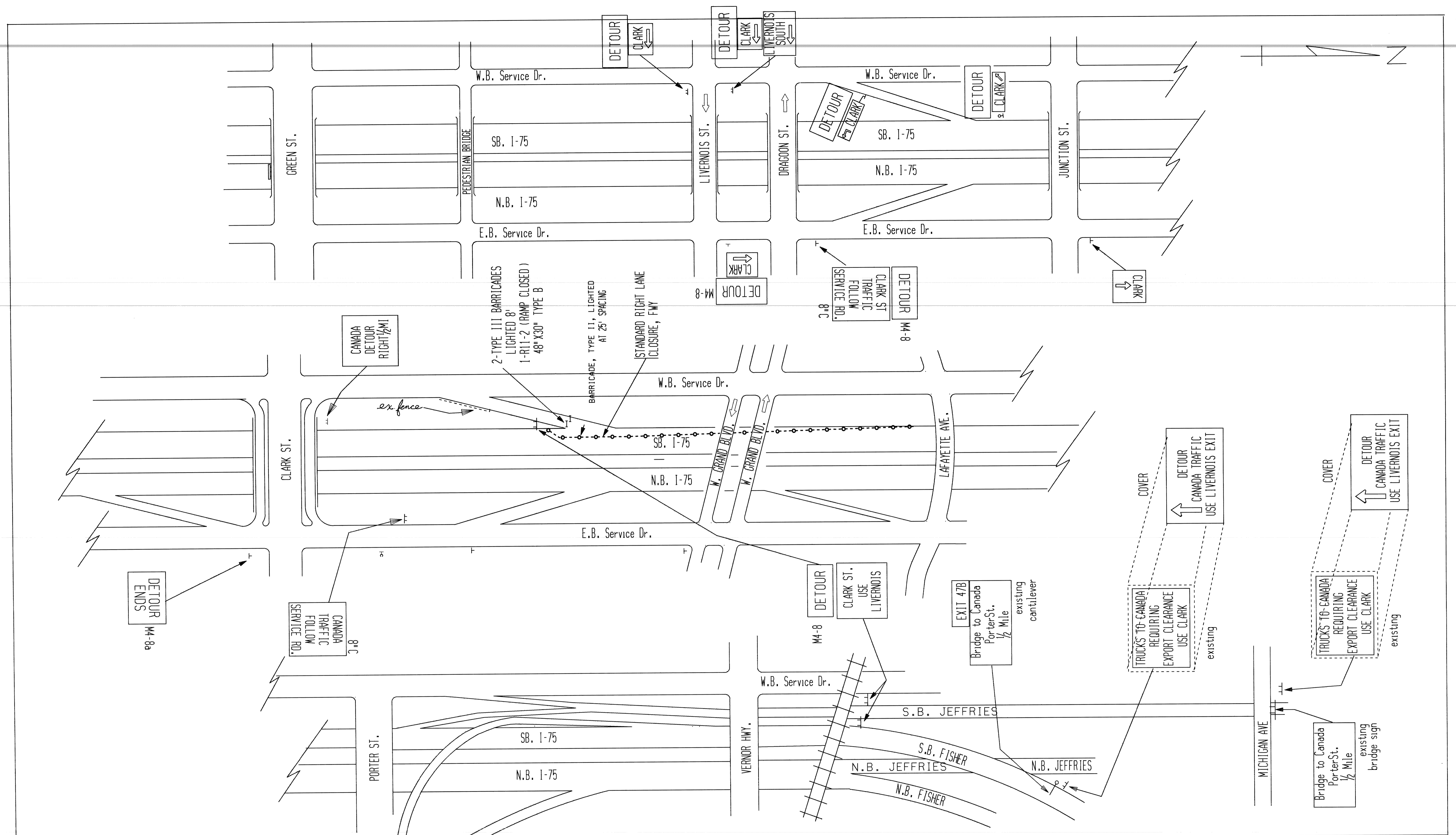

S.B. I-75 EXIT TO CLARK CLOSED

DATE 6 / 23 / 95	SCALE NONE	CONT. SEC. 82194	SHEET NO. 12
---------------------	---------------	---------------------	-----------------

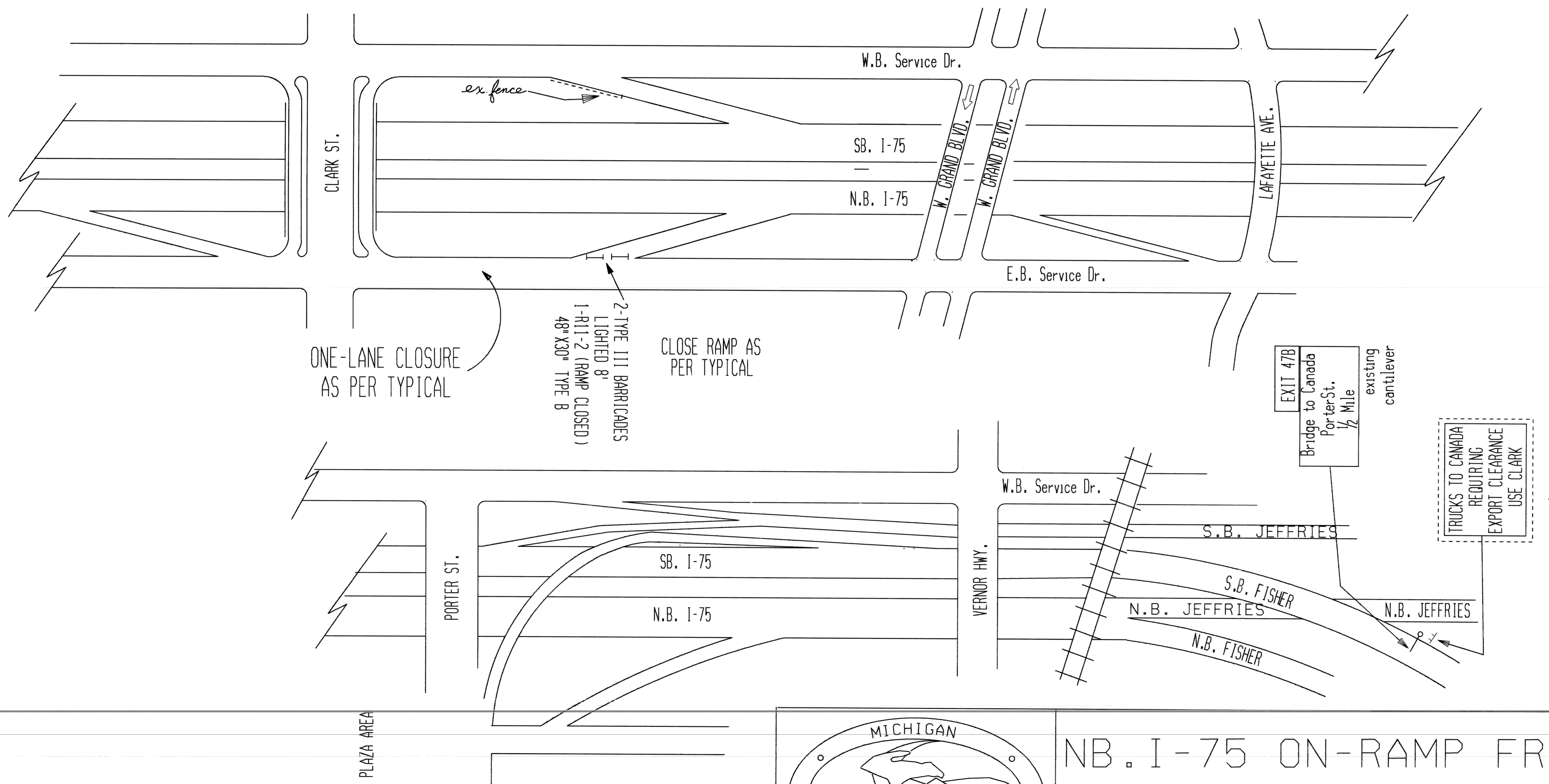
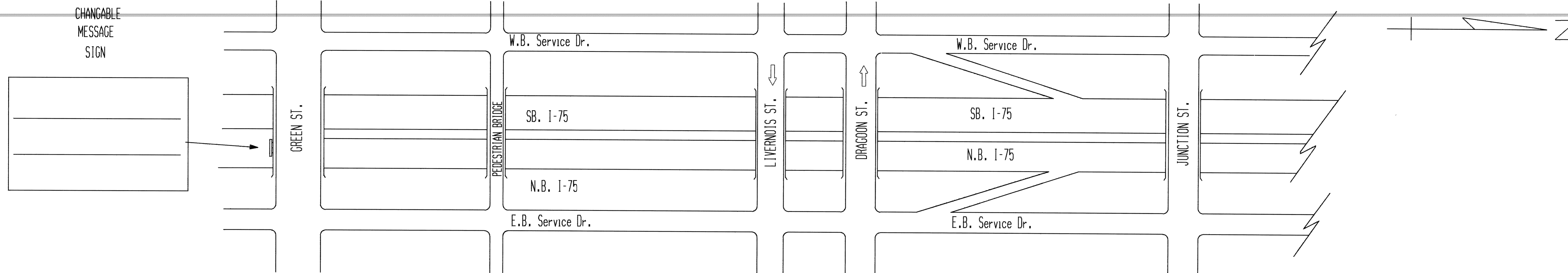

NOTE: ONE LANE SHALL REMAIN OPEN AT ALL TIMES

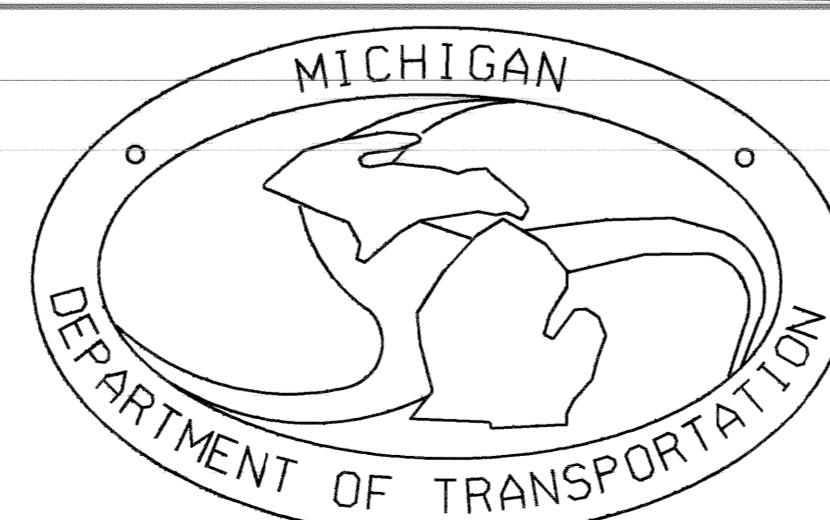

NB. I-75 ON-RAMP FROM CLARK CLOSED

DATE 6 / 23 / 95	SCALE NONE	CONT. SEC. 82194	SHEET NO. 13
---------------------	---------------	---------------------	-----------------

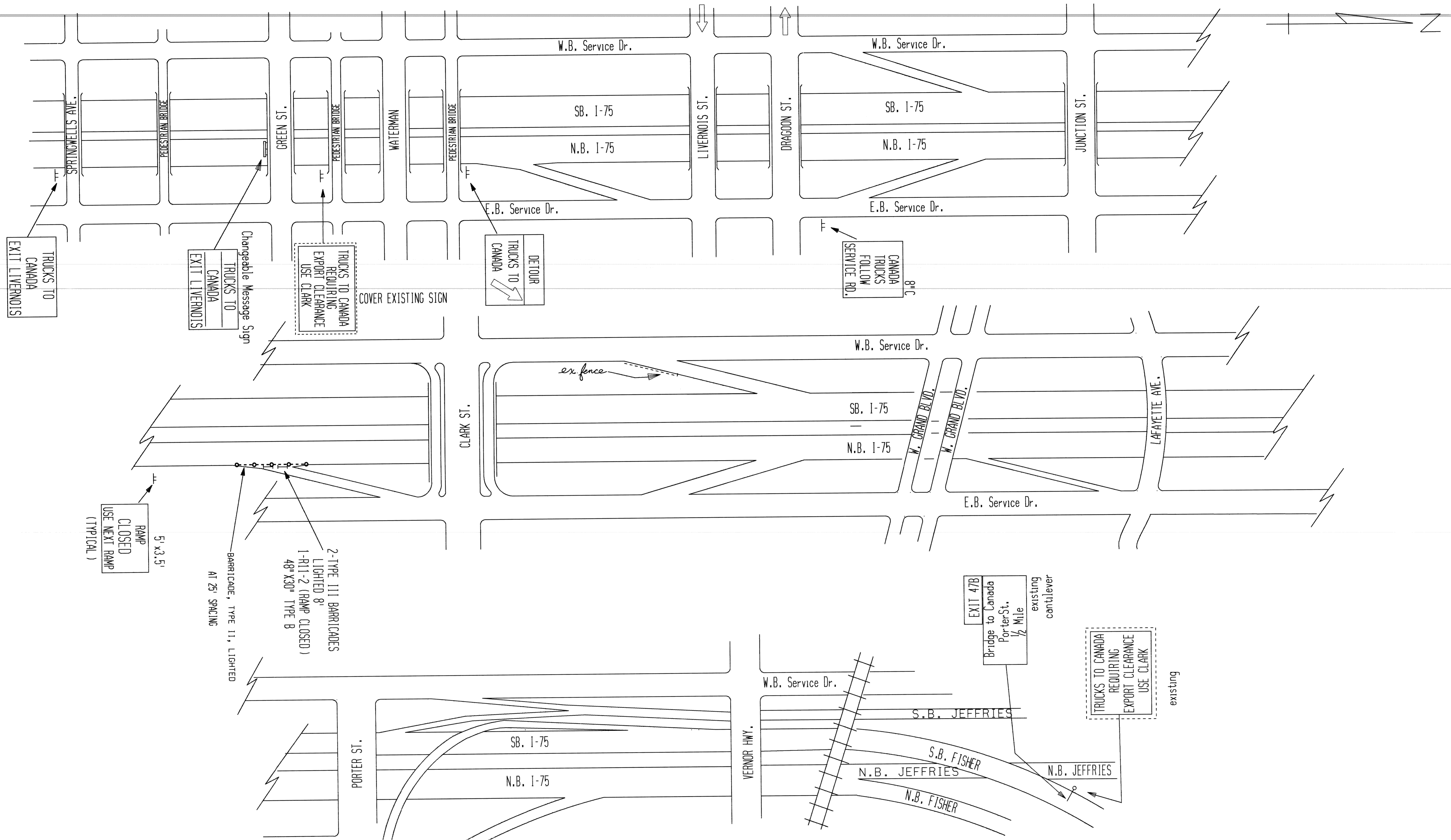

TRUCKS TO CANADA
EXIT LIVERNOIS

Changeable Message Sign
TRUCKS TO CANADA
EXIT LIVERNOIS

TRUCKS TO CANADA
REQUIRING
EXPORT CLEARANCE
USE CLARK

COVER EXISTING SIGN

DETOUR
TRUCKS TO
CANADA

CANADA
TRUCKS
FOLLOW
SERVICE RD.

RAMP
CLOSED
USE NEXT RAMP
(TYPICAL)

5' x 3.5'

BARRICADE, TYPE II, LIGHTED
AT 25' SPACING

2-TYPE III BARRICADES
LIGHTED 8'

1-R11-2 (RAMP CLOSED)
48" X 30" TYPE B

EXIT 47B
Bridge to Canada
Porter St.
1/2 Mile

existing
cantilever

TRUCKS TO CANADA
REQUIRING
EXPORT CLEARANCE
USE CLARK

existing

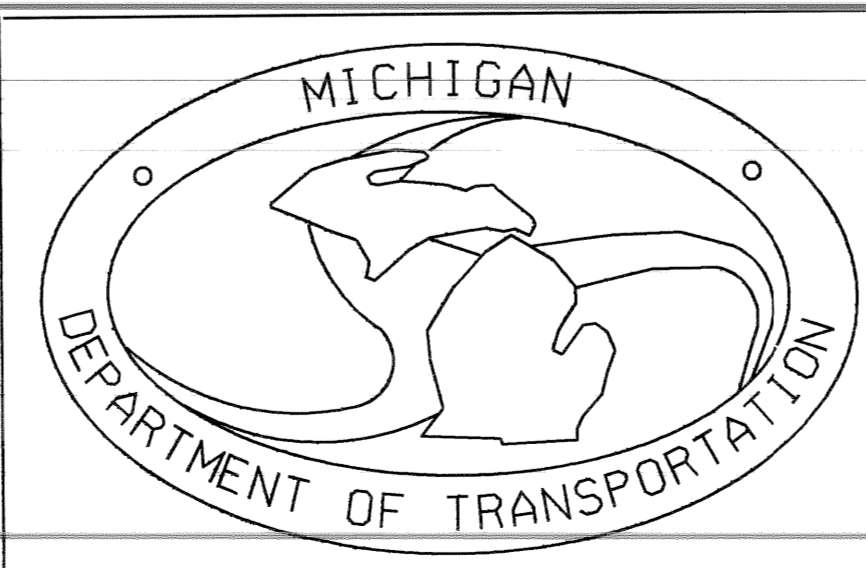

NB. I-75 EXIT TO CLARK CLOSED

DATE
6 / 23 / 95

SCALE
NONE

CONT. SEC.
82194

SHEET NO.
14

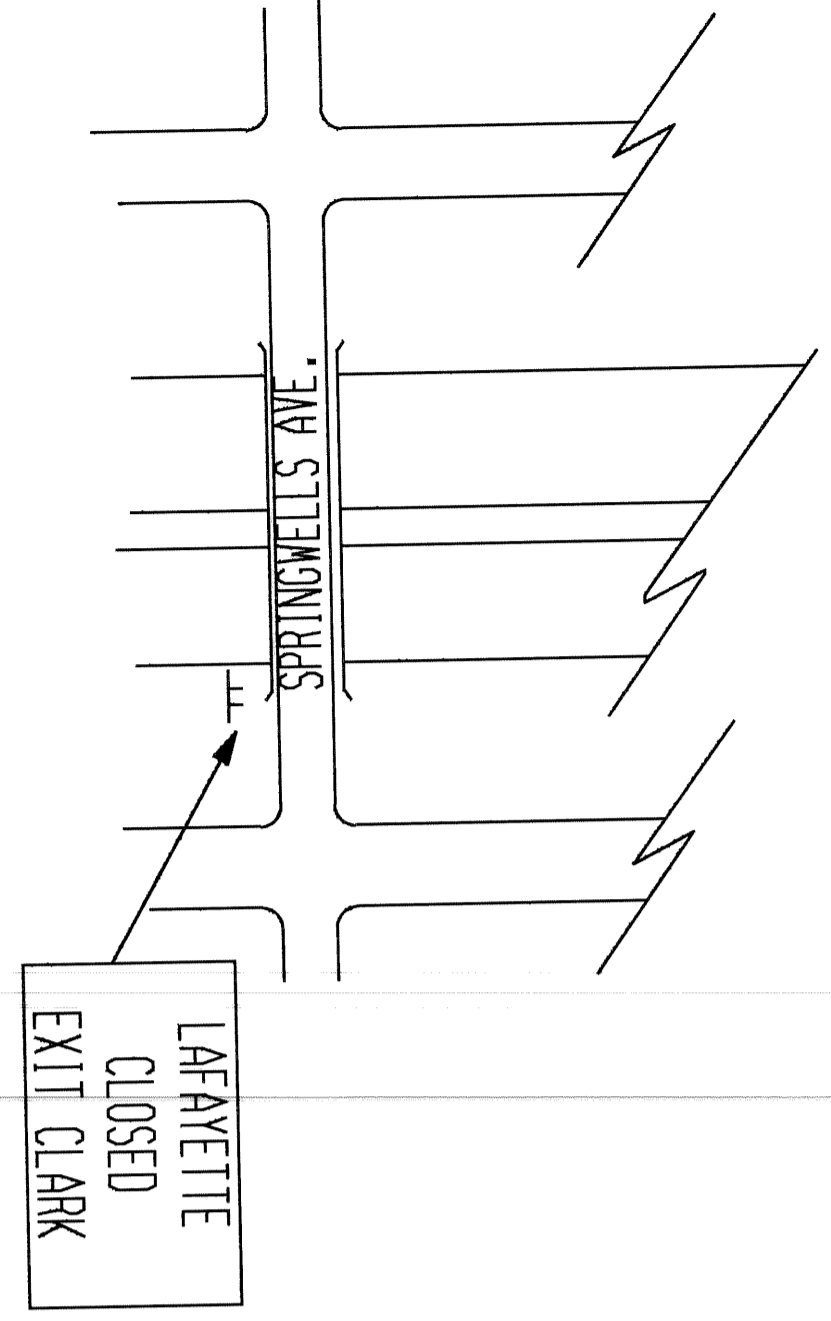

8' x 4.5' 10" C



2 CHANGABLE MESSAGE SIGNS

GREEN ST.

W.B. Service Dr.

SB. I-75

N.B. I-75

E.B. Service Dr.

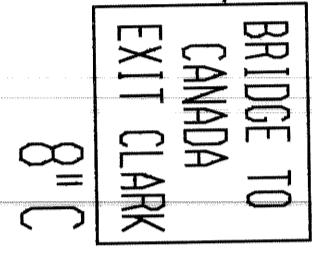

8" C

W.B. Service Dr.

SB. I-75

N.B. I-75

E.B. Service Dr.

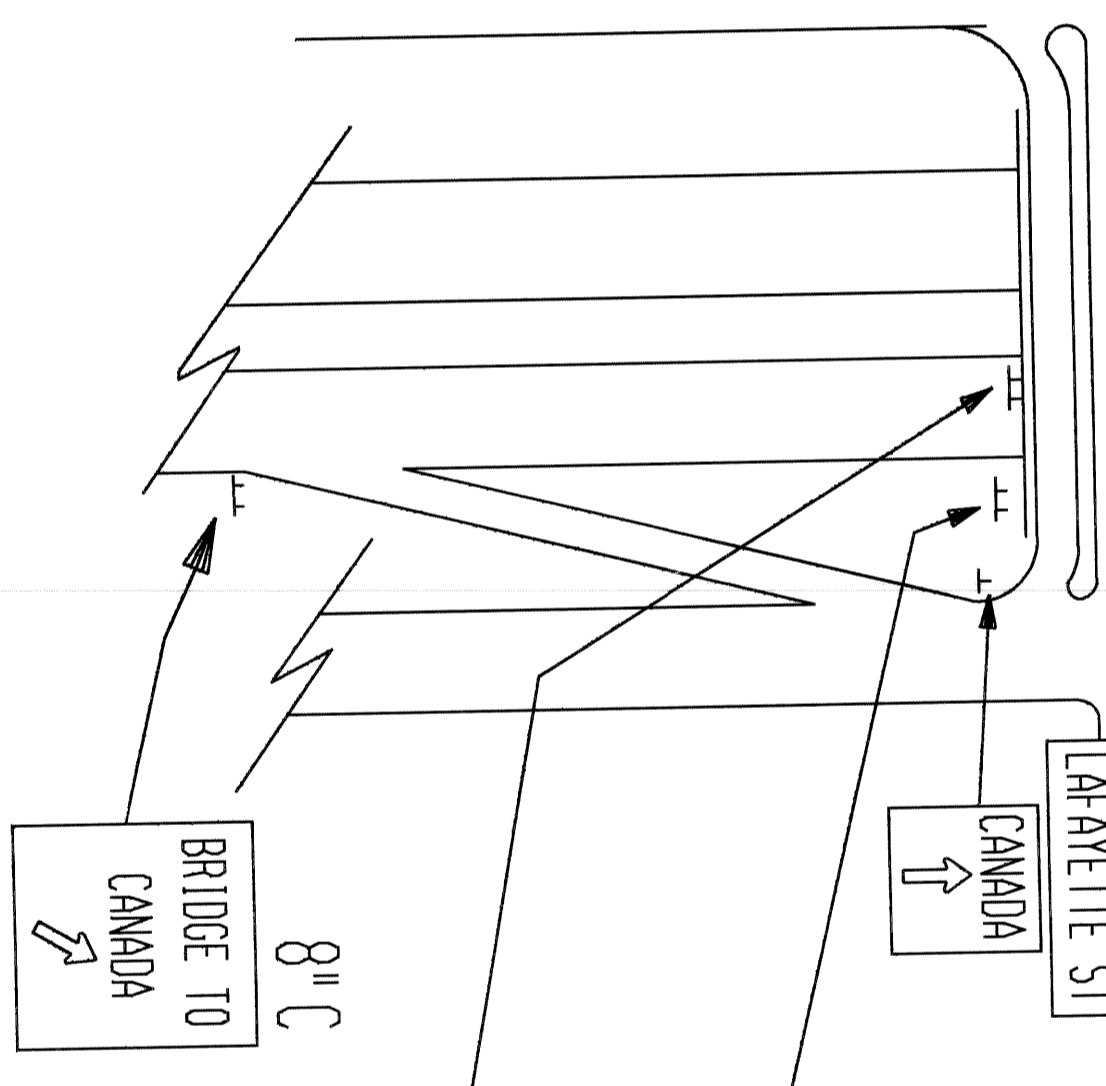
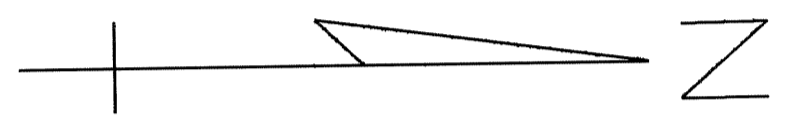

CLARK ST.

ex. fence

W.B. Service Dr.

SB. I-75

N.B. I-75

E.B. Service Dr.

BARRICADE, TYPE 11, LIGHTED AT 25' SPACING
2-TYPE 111 BARRICADES LIGHTED 8'
1-R11-2 (RAMP CLOSED)
48" X 30" TYPE B

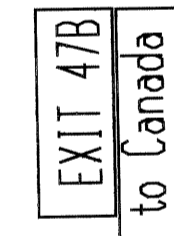

existing cantilever

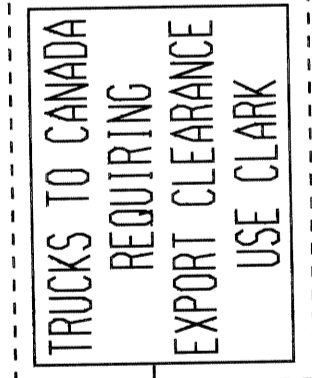

existing

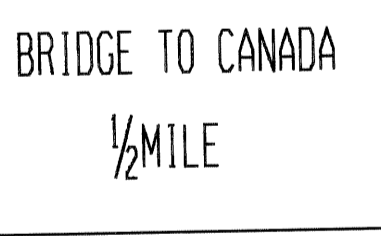

NOTE:
IF THE ABOVE SIGN IS MOUNTED ON THE BRIDGE AT THIS LOCATION, THEN ERECT THE FOLLOWING SIGN IN FRONT OF THE BRIDGE IN THE GRASSY AREA:



8" c 3' x 6.5'

PORTER ST.

SB. I-75

N.B. I-75

VERNOR HWY.

W.B. Service Dr.

S.B. JEFFRIES

S.B. FISHER

N.B. JEFFRIES

N.B. FISHER

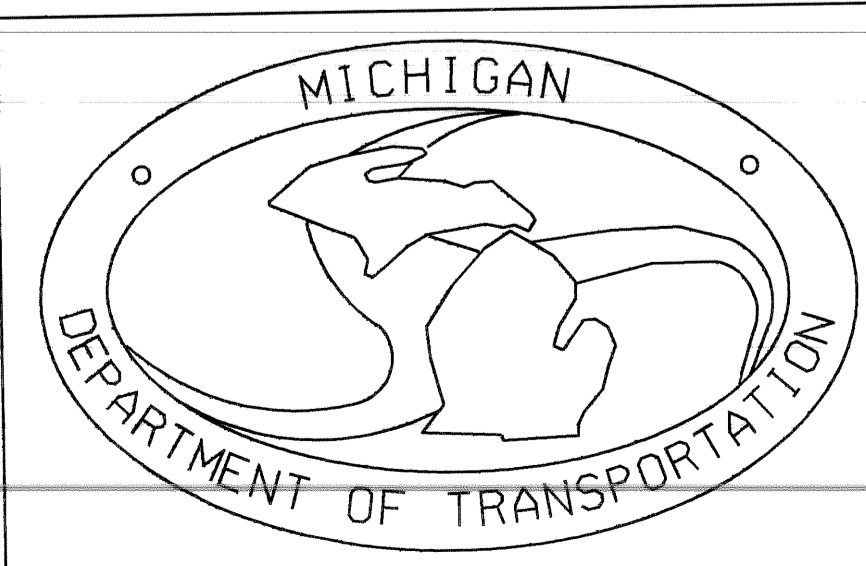

NB. I-75 EXIT TO LAFAYETTE CLOSED

DATE
6 / 23 / 95

SCALE
NONE

CONT. SEC.
82194

SHEET NO.
15

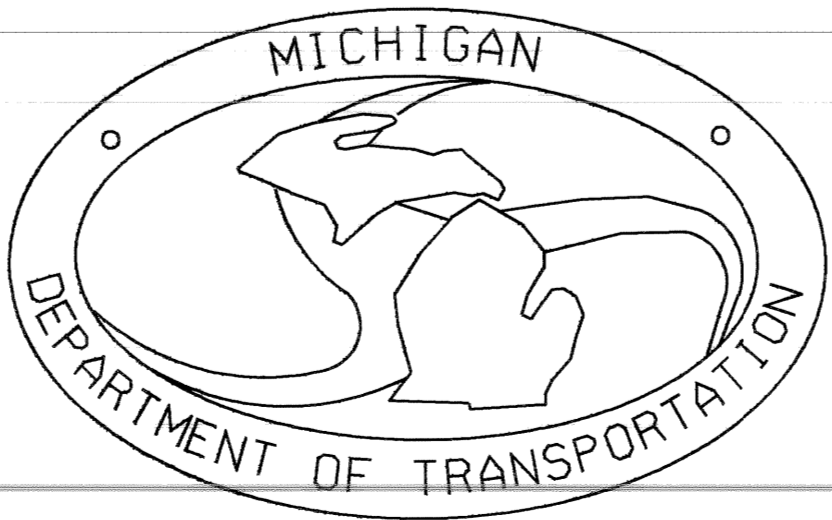
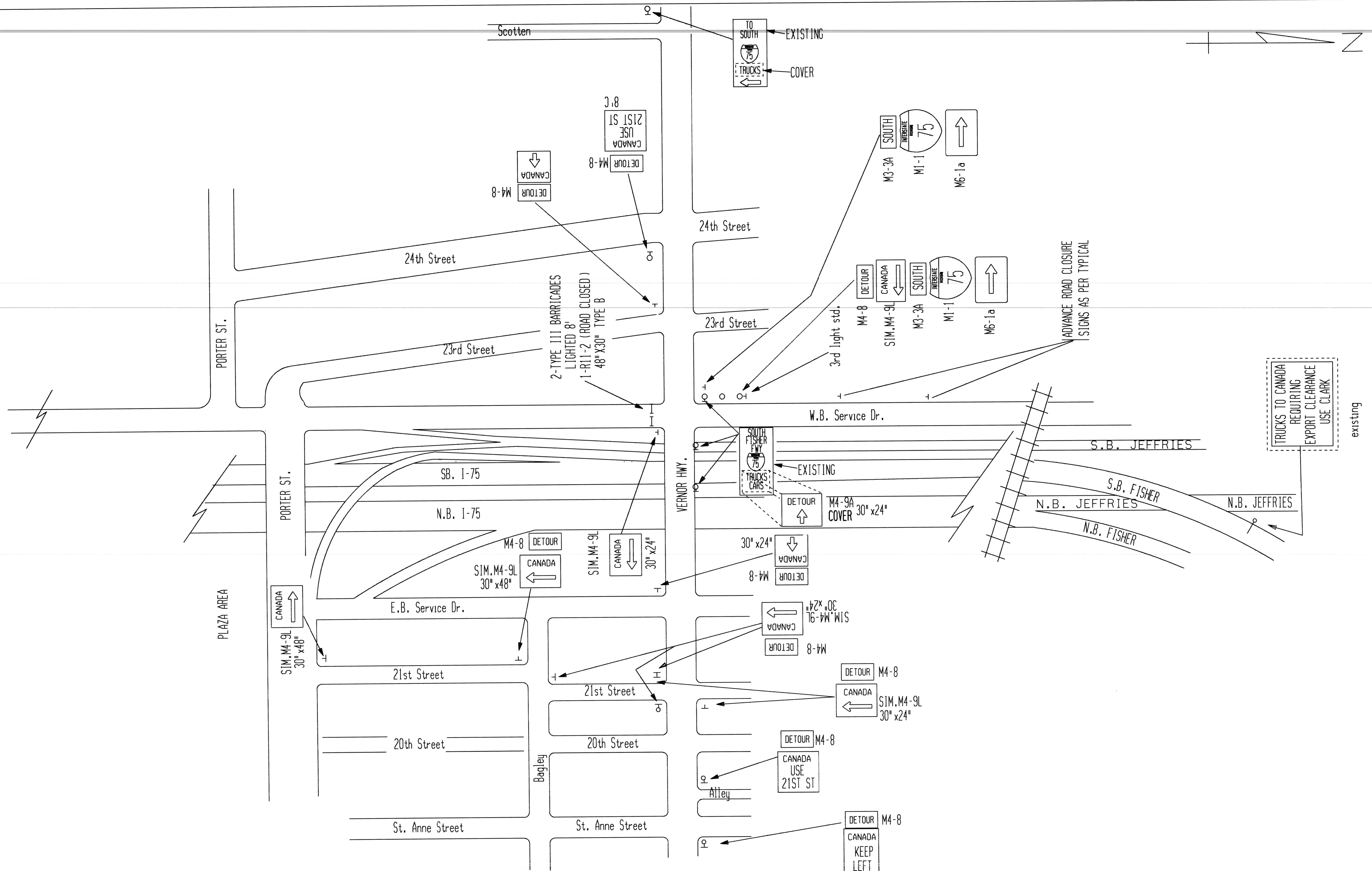

SERVICE RD. BET. VERNOR AND PORTER CLOSED

DATE 6 / 23 / 95	SCALE NONE	CONT. SEC. 82194	SHEET NO. 16
---------------------	---------------	---------------------	-----------------

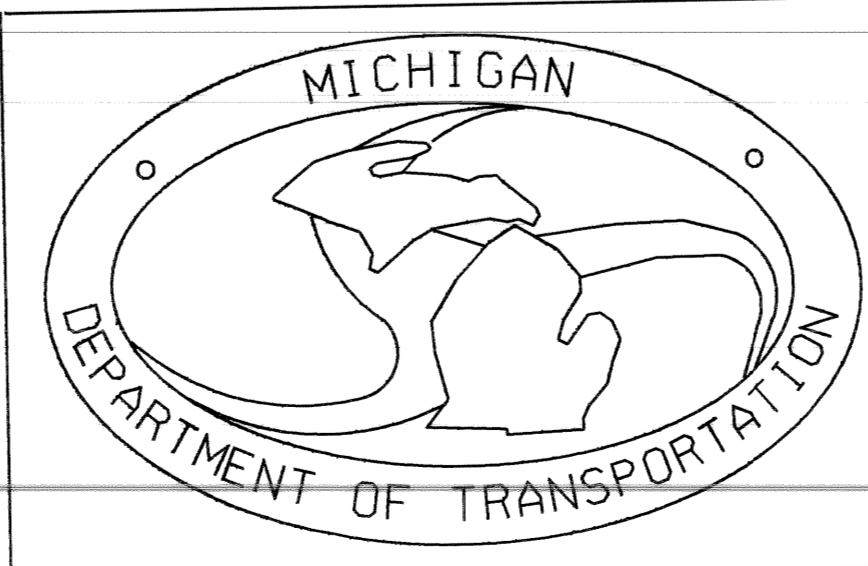
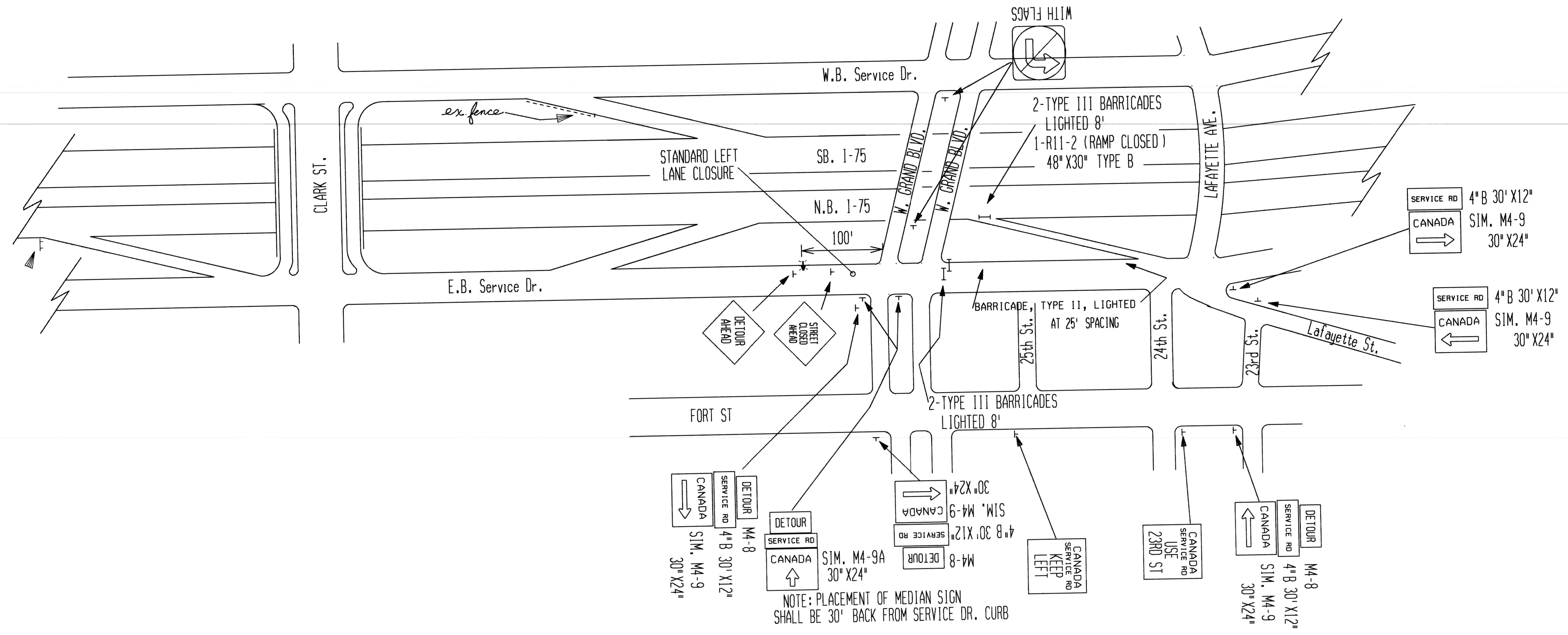
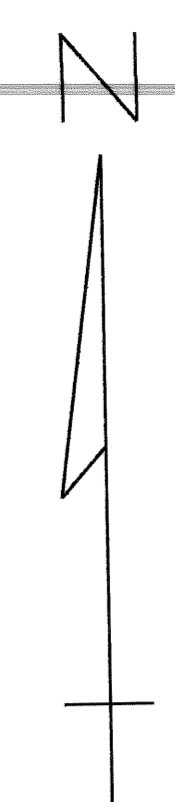

NB. SERVICE RD. CLOSED AT GRAND BLVD.

DATE 6 / 23 / 95	SCALE NONE	CONT. SEC. 82194	SHEET NO. 17
---------------------	---------------	---------------------	-----------------

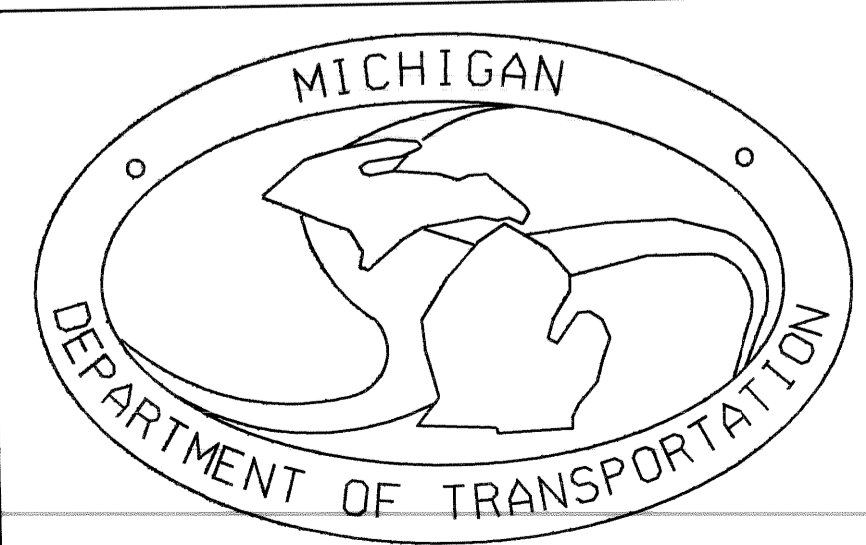
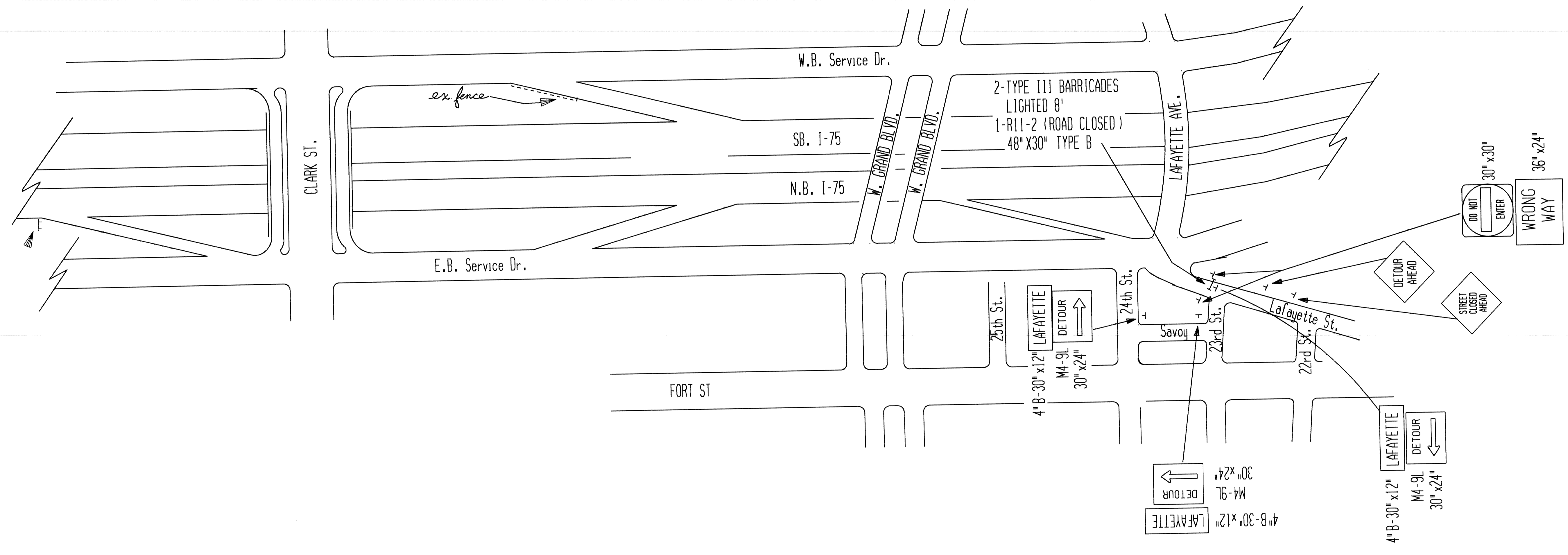

WB. LAFAYETTE CLOSED AT NB. SERVICE RD.

DATE 6 / 23 / 95	SCALE NONE	CONT. SEC. 82194	SHEET NO. 18
---------------------	---------------	---------------------	-----------------

/usr2/traf/inv/82194/plaza49a.dgn

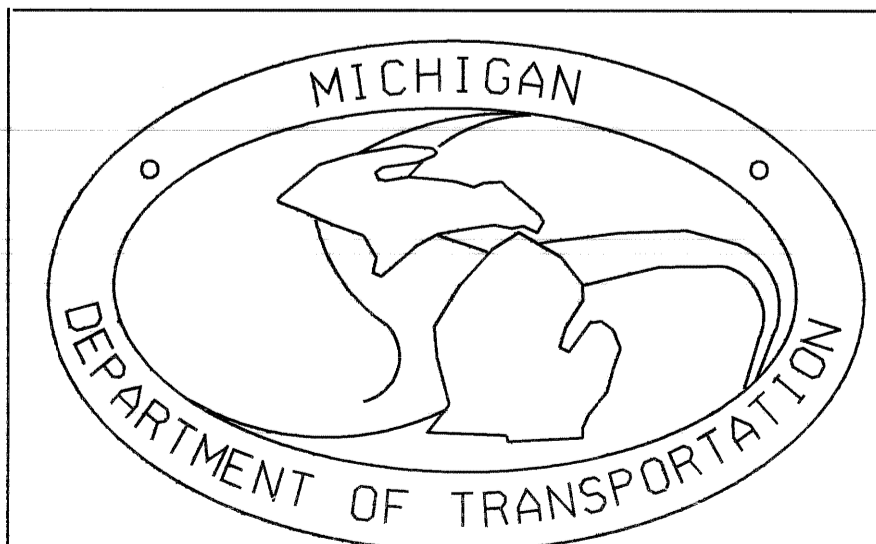
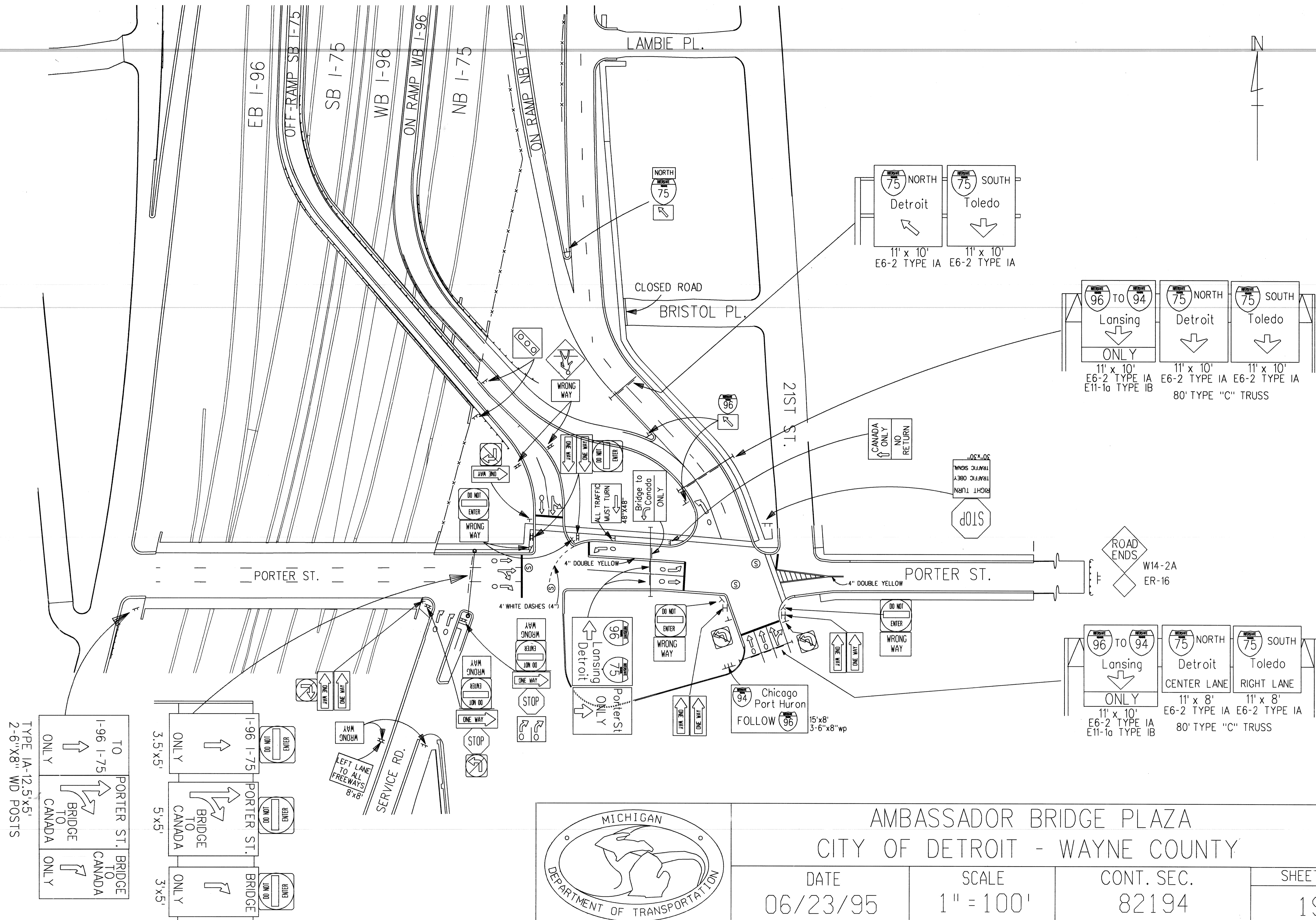
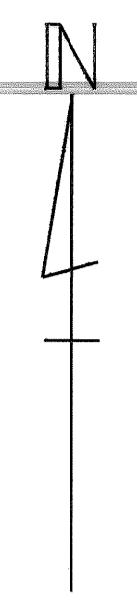

AMBASSADOR BRIDGE PLAZA
CITY OF DETROIT - WAYNE COUNTY

DATE 06/23/95	SCALE 1" = 100'	CONT. SEC. 82194	SHEET NO. 19
------------------	--------------------	---------------------	-----------------

TO I-96 I-75
PORTER ST. BRIDGE TO CANADA
ONLY
TYPE IA-12.5'x5'
2-6"X8" WD POSTS

ONLY I-96 I-75
PORTER ST. BRIDGE TO CANADA
ONLY
3.5'x5'

ONLY I-96 I-75
PORTER ST. BRIDGE TO CANADA
ONLY
5'x5'

ONLY I-96 I-75
PORTER ST. BRIDGE TO CANADA
ONLY
3'x5'

LEFT LANE TO ALL FREEWAYS
8'x8'

SERVICE RD.

ROAD ENDS
W14-2A
ER-16

Chicago Port Huron
FOLLOW I-96
15'x8'
3-6"X8"wp

ONLY I-96 TO I-94
Lansing
ONLY
11' x 10'
E6-2 TYPE IA
E11-1a TYPE IB

ONLY I-75 NORTH
Detroit
CENTER LANE
11' x 8'
E6-2 TYPE IA

ONLY I-75 SOUTH
Toledo
RIGHT LANE
11' x 8'
E6-2 TYPE IA

80' TYPE "C" TRUSS

ONLY I-75 NORTH
Detroit
11' x 10'
E6-2 TYPE IA

ONLY I-75 SOUTH
Toledo
11' x 10'
E6-2 TYPE IA

ONLY I-96 TO I-94
Lansing
ONLY
11' x 10'
E6-2 TYPE IA
E11-1a TYPE IB

ONLY I-75 NORTH
Detroit
11' x 10'
E6-2 TYPE IA

ONLY I-75 SOUTH
Toledo
11' x 10'
E6-2 TYPE IA

80' TYPE "C" TRUSS