

PLAN INDEX	
SH. NO.	DESCRIPTION
1	TITLE SHEET
2	NOTE SHEET
3	DETOUR ROUTE
4	GENERAL PLAN OF SITE
5-6	GENERAL PLAN OF STRUCTURE
7	EX. GENERAL PLAN OF SITE
8-9	EX. GENERAL PLAN OF STRUCTURE (REMOVAL)
10-11	EX. ABUTMENT A DETAILS (REMOVAL)
12-13	EX. ABUTMENT B DETAILS (REMOVAL)
14-16	EX. STRUCTURAL STEEL DETAILS (REMOVAL)
17	ABUTMENT REPAIR DETAILS
18-19	STRUCTURAL STEEL DETAILS
20-22	PIN AND HANGER DETAILS
23	EXPANSION JOINT DETAILS
24-30	SUPERSTRUCTURE DETAILS
31-33	SLAB AND SCREED DETAILS
34	STEEL REINFORCEMENT DETAILS
35-38	APPROACH DETAILS
39-55	STREET LIGHTING DETAILS
56-60	SPECIAL DETAILS

CITY OF DETROIT
 IN COOPERATION WITH
MICHIGAN DEPARTMENT OF TRANSPORTATION
 AND
FEDERAL HIGHWAY ADMINISTRATION
 PLAN AND PROFILE OF PROPOSED
 REHABILITATION OF THE
EAST GRAND BOULEVARD BRIDGE
 OVER THE
DETROIT CONNECTING RAILROAD

FEDERAL PROJECT NO.: STP 0782 (130)
 FEDERAL ITEM NO.: HH 5103
 STATE BRIDGE NO.: R01 OF 82-22-54
 JOB NO.: 86173A
 CONTROL SECTION NO.: STU 82400

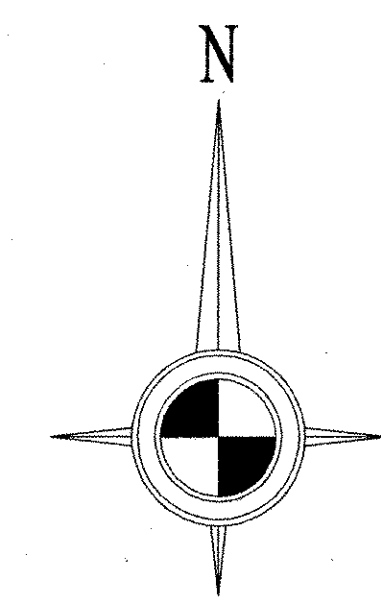

CITY OF DETROIT
 SECTION 29
 T1S, R12E

PROJECT
 LOCATION
 R01 of 82-22-54

TRAFFIC DATA:		
	YEAR	YEAR
ADT	2007	2027
DHV	3956	7118
COMM%	356	648
DESIGN SPEED	9.0%	9.0%
POSTED SPEED		35 MPH

TITLE SHEET LEGEND	
PROPOSED BRIDGE PROJECT	
EXISTING ROADS	
CITY STREET	
COUNTY	
STATE ROUTES	
FEDERAL DIVIDED ROUTES	
FEDERAL DIVIDED INTERSTATE ROUTES	
SECTION LINE	
CITY, VILLAGE OR TOWNSHIP LIMITS	
RAILROADS	

CONTRACT FOR: DECK REPLACEMENT, PIN AND HANGER REPLACEMENT AND
 RELATED APPROACH WORK FOR EAST GRAND BOULEVARD OVER DETROIT
 CONNECTION RAILROAD AND RIVARD STREET
 DATE: 1/16/07

BRIDGE PLANS WERE PREPARED FOR THE CITY OF DETROIT BY

RONALD G. WOOLFE
ENGINEER
NO. 23345

DLZ
151 WEST CONGRESS SUITE 328
DETROIT, MICHIGAN 48226
(313) 961-4040

LICENSED PROFESSIONAL ENGINEER

4/14/08
 DATE

LOCAL AUTHORITY APPROVAL
 CITY OF DETROIT
 CITY ENGINEERING DIVISION
 DEPARTMENT OF PUBLIC WORKS

APPROVED BY _____ HEAD ENGINEER DATE _____

 APPROVED BY _____ CITY ENGINEER DATE 4/18/08

PREPARED UNDER THE SUPERVISION OF

 LICENSED PROFESSIONAL ENGINEER 19128
 REGISTRATION NO.

CITY OF DETROIT
 ORGANIZATION
 CITY ENGINEERING DIVISION
 900 CADILLAC TOWER
 DETROIT, MI 48226
 ADDRESS

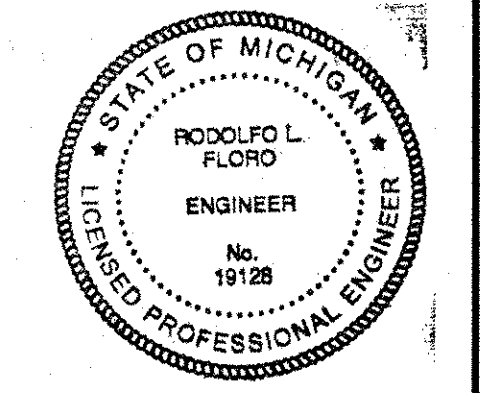

MICHIGAN DEPARTMENT OF TRANSPORTATION		FEDERAL NUMBERS		SHEET
CONTROL SECTION	JOB NUMBER	PROJECT	ITEM	NO.
STU 82400	86173A			1

JOB NUMBER: STU 82400-86173A
 CONTROL SECTION: STU 82400
 DATE: 2/8/07
 CORRECTED BY: DAF
 CHECKED BY: KCK
 DATE: 1/10/07
 DRAWN BY: east_grand_title.dgn

CITY OF DETROIT STANDARD PLANS

WHERE THE FOLLOWING ITEMS ARE CALLED FOR ON THE PLANS THEY ARE TO BE CONSTRUCTED ACCORDING TO THE STANDARD PLAN GIVEN BELOW OPPOSITE EACH ITEM UNLESS OTHERWISE INDICATED AS INCLUDED IN THE PROPSAL.

STANDARD CURB DETAILS	C-4380
STANDARD SEWER AND DROP MANHOLES	C-4387
MANHOLE FRAME AND COVER	C-4391
FLAT TYPE GRATE AND FRAME	C-4392
BARRICADES AND LIGHTED ARROW	C-4730
PAVEMENT REINFORCEMENT	C-4942R
REINFORCED CONCRETE PAVEMENT JOINTS	C-4943
TYPICAL JOINT LAYOUT FOR REINFORCED CONCRETE PAVEMENT	C-4992
STANDARD CATCH BASINS "A" AND "B" AND FLAT GRATE AND FRAME	C-5028
SIDEWALK RAMP DETAILS	R-28-A

MDOT STANDARD PLANS

WHERE THE FOLLOWING ITEMS ARE CALLED FOR ON THE PLANS THEY ARE TO BE CONSTRUCTED ACCORDING TO THE STANDARD PLAN GIVEN BELOW OPPOSITE EACH ITEM UNLESS OTHERWISE INDICATED.

INTEGRAL CURB AND INTEGRAL CURB & GUTTER	R-31-D
LOAD TRANSFER ASSEMBLIES FOR TRANSVERSE JOINTS	R-40-F
CONCRETE BARRIER	R-49-F
UTILITY TRENCHES	R-83-B
SOIL EROSION & SEDIMENTATION CONTROL MEASURES	R-96-D
PLACEMENT OF TEMPORARY CONCRETE BARRIER	R-126-F
BRIDGE RAILING, AESTHETIC PARAPET TUBE	B-25-E
FENCING FOR BRIDGE RAILING, AESTHETIC PARAPET TUBE	B-41-B

GENERAL NOTES

THE REHABILITATION DESIGN IS BASED ON CURRENT AASHTO STANDARD SPECIFICATIONS FOR HIGHWAY BRIDGES HS20-44 LOADING. LIVE LOAD PLUS IMPACT DEFLECTION DOES NOT EXCEED 1/1000 OF SPAN LENGTH AND 1/375 OF CANTILEVER ARM. THE LOAD FACTOR METHOD OF DESIGN WAS USED FOR THIS STRUCTURE. THE ORIGINAL STRUCTURE WAS DESIGNED FOR HS20-44 LOADING.

EXCEPT WHERE OTHERWISE INDICATED ON THESE PLANS, OR IN THE PROPOSAL AND SUPPLEMENTAL SPECIFICATIONS CONTAINED HEREIN, ALL MATERIALS AND WORKMANSHIP SHALL BE ACCORDING TO THE MICHIGAN DEPARTMENT OF TRANSPORTATION STANDARD SPECIFICATIONS FOR CONSTRUCTION 2003 EDITION.

ALL EXPOSED CONCRETE CORNERS SHOWN SQUARE ON THE PLANS SHALL BE BEVELED WITH 1/2" TRIANGULAR MOLDINGS EXCEPT AS OTHERWISE NOTED.

THE PROPOSED IMPROVEMENTS COVERED BY THESE PLANS ARE IN ACCORDANCE WITH THE AASHTO: A POLICY ON GEOMETRIC DESIGN OF HIGHWAYS AND STREETS, 2004.

BIDDERS WILL BE FURNISHED WITH SCANNED IMAGES OF PLAN SHEETS OF THE EXISTING STRUCTURE IF REQUESTED.

THE DESIGN OF THE STRUCTURAL MEMBERS IS BASED ON MATERIAL OF THE FOLLOWING GRADES AND STRESSES:

CONCRETE GRADE S2	f'c = 3,000 psi
CONCRETE GRADE D	f'c = 4,000 psi
STEEL REINFORCEMENT	fy = 60,000 psi
EX. STRUCTURAL STEEL:	
ASTM A588W GRADE 50	fy = 50,000 psi
STRUCTURAL STEEL PINS:	
ASTM A276	fy = 36,000 psi
TEMP SUPPORT HANGER RODS:	
ASTM A193 GRADE B7 (AISI 4140)	
2 1/2" AND UNDER	ft = 125,000 psi
	fy = 105,000 psi
OVER 2 1/2" TO 4"	ft = 115,000 psi
	fy = 95,000 psi
OVER 4" TO 7"	ft = 100,000 psi
	fy = 75,000 psi

THE REGULATED WASTE ACTIVITY IDENTIFICATION NUMBERS FOR THIS PROJECT ARE AS FOLLOWS:

CONTROL SECTION	NUMBER
STU 82400	

TRAFFIC DATA:	YEAR	YEAR
	2007	2027
ADT	3956	7118
DHV	356	648
COMM%	9.0%	9.0%
DESIGN SPEED		35 MPH
POSTED SPEED		35 MPH

REVISIONS	DESCRIPTION	DATE	BY



EAST GRAND BLVD OVER
DETROIT CONNECTING RAILROAD
MDOT JOB NO. 86173A | STRUCTURE NO. R01 of 82-22-54

NOTE SHEET

DATE: 04/16/08
DLZ JOB NO. 0642-6090-00
SHEET NO. 2 OF 60

FILE NAME: east grand title.dgn DRAWN BY: DMF DATE: 1/10/07 CHECKED BY: KCK DATE: 1/16/07 CORRECTED BY: DAF DATE: 2/8/07

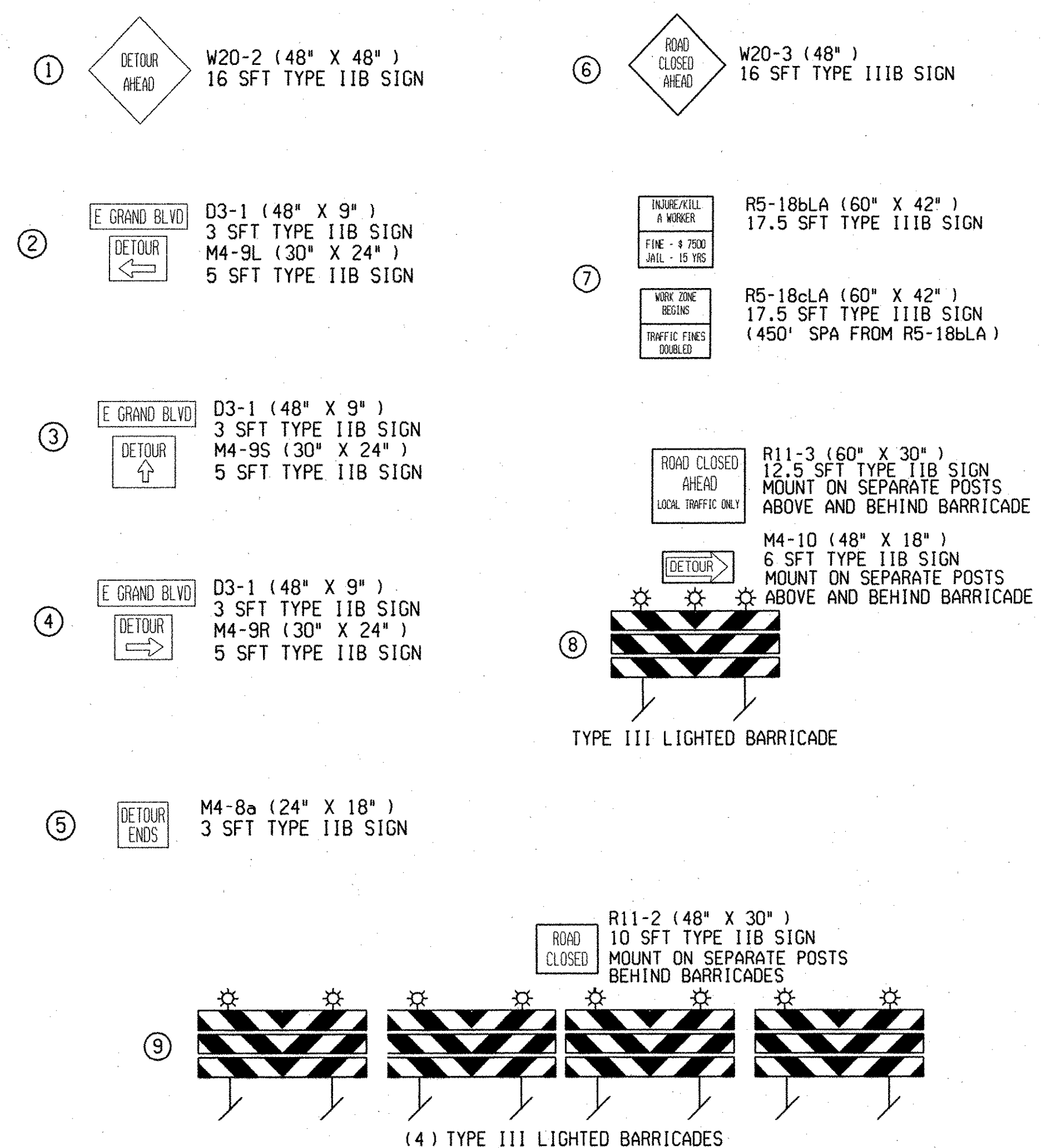
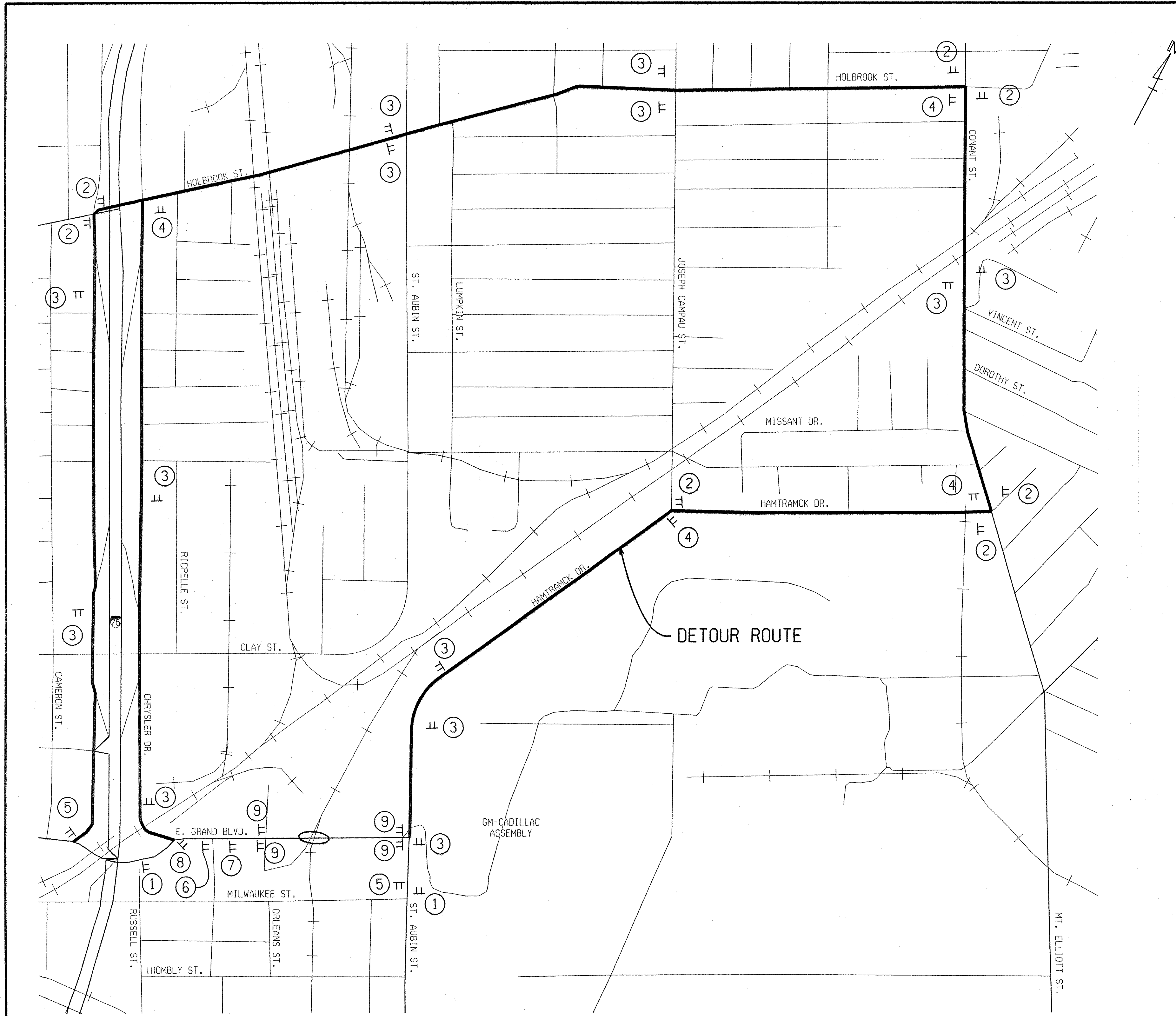

MISCELLANEOUS QUANTITIES	
17	Ea Barricade, Type III, High Intensity, Double sided, Furn
17	Ea Barricade, Type III, High Intensity, Double Sided, Oper
10	Ea Plastic Drum, High Intensity, Lighted, Furn
10	Ea Plastic Drum, High Intensity, Lighted, Oper
340	Sft Sign, Type B, Temp, Prismatic, Furn
340	Sft Sign, Type B, Temp, Prismatic, Oper
1	LS Minor Traf Devices

REVISIONS	DESCRIPTION	DATE	BY



EAST GRAND BLVD OVER
DETROIT CONNECTING RAILROAD
MDOT JOB NO. 86173A STRUCTURE NO. R01 of 82-22-54

DETROUR ROUTE

DATE: 04/16/08
DLZ JOB NO. 0642-6090-00
SHEET NO. 3 OF 60

DATE: 07/06/06 DATE: 07/06/07 CORRECTED BY: KCK CHECKED BY: KCK DATE: 07/06/07 DRAWN BY: DW FILE NAME: east_grand_detour.dgn

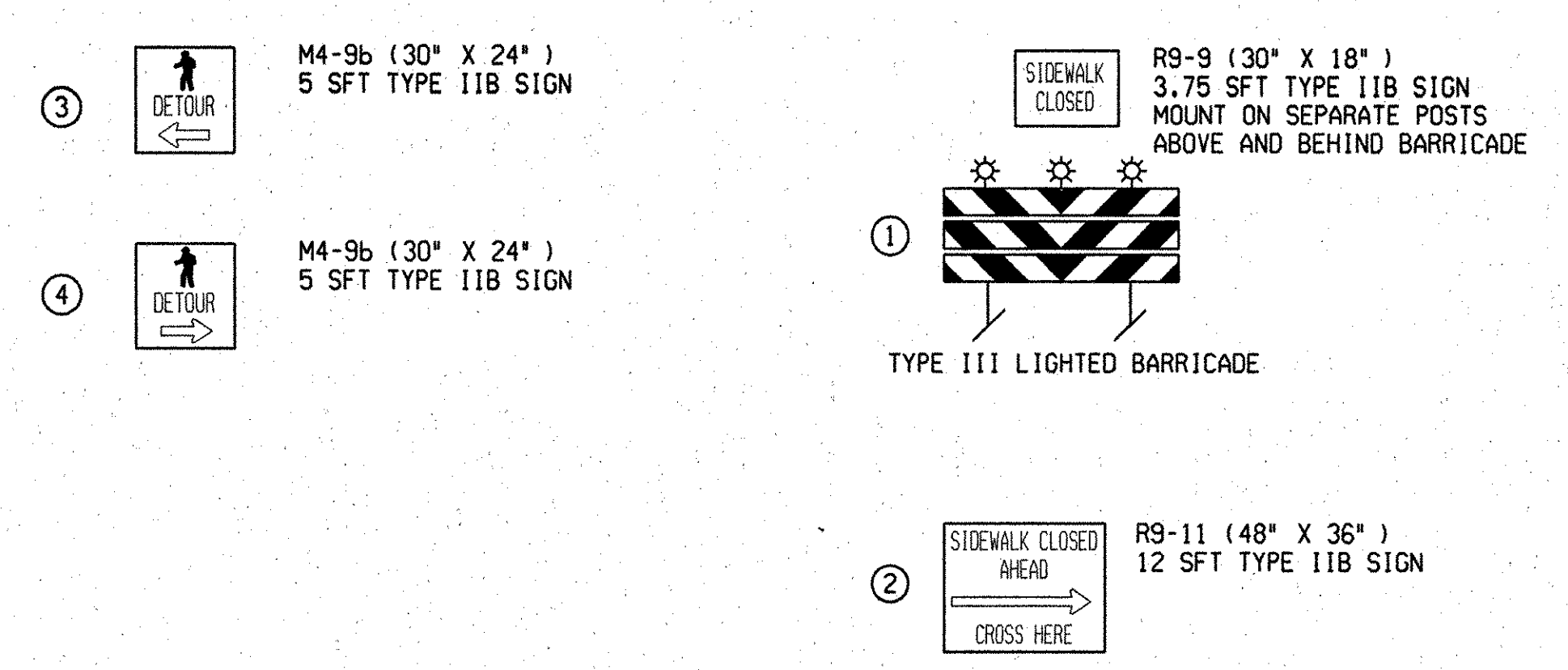
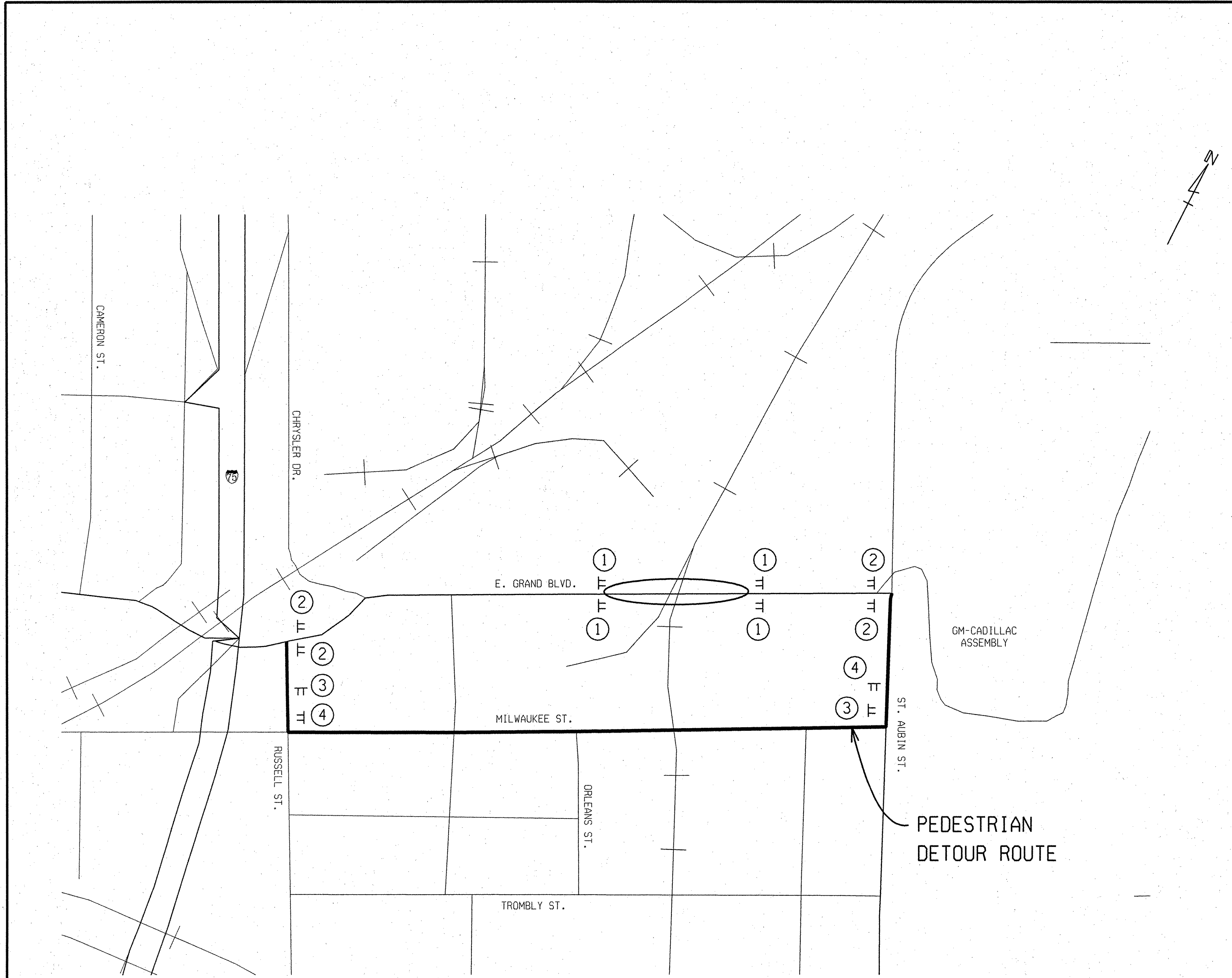

MISCELLANEOUS QUANTITIES	
4	Ea Barricade, Type III, High Intensity, Double sided, Furn
4	Ea Barricade, Type III, High Intensity, Double Sided, Oper
83	Sft Sign, Type B, Temp, Prismatic, Furn
83	Sft Sign, Type B, Temp, Prismatic, Oper

REVISIONS	DESCRIPTION	DATE	BY

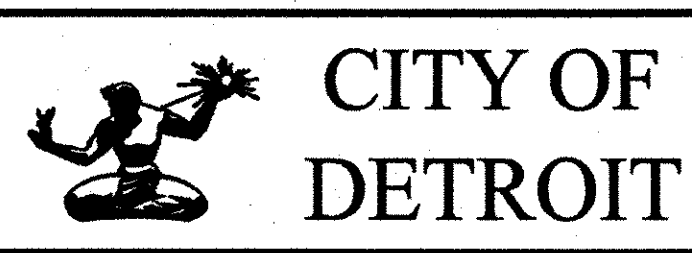

EAST GRAND BLVD OVER
 DETROIT CONNECTING RAILROAD
 MDOT JOB NO. 86173A STRUCTURE NO. R01 of 82-22-54

DETOUR ROUTE

DATE: 04/16/08
 DLZ JOB NO. 0642-6090-00
 SHEET NO. 3A OF 60

DATE: 2/8/07

CORRECTED BY: DAF

DATE: 2/7/07

CHECKED BY: KCK

DATE:

DRAWN BY:

FILE NAME: east_grand_si.dgn

BENCH MARKS	
BM 100 SOUTHEAST ANCHOR BOLT LAMP POLE WEST SIDE OF ENTRANCE DETROIT ENERGY RECYCLING CENTER NORTH SIDE EAST GRAND BLVD WEST SIDE OF BRIDGE. NORTHING: 10054.0520 EASTING: 19901.8540	EL 149.59
BM 101 BENCH TIE SOUTH SIDE POWER POLE *21490 NORTH SIDE OF BRIDGE DOWN UNDER EAST SIDE OF PARKING LOT TO MILWAUKEE PARK LOFTS NORTHING: 10453.1930 EASTING: 20973.8950	EL 150.69

WITNESSES	
WITNESSES TO CP1; 2" MAG NAIL IN CONC ISLAND NORTH OF SERVICE DRIVE SOUTH OF EAST GRAND BLVD WEST SIDE OF BRIDGE N 20° W BACK OF CURB 4.00 FT S 70° W BACK OF CURB WEST END OF ISLAND 35.70 FT S 20° E BACK OF CURB 3.40 FT NORTHING: 10000.0000 EASTING: 20000.000	
WITNESSES TO CP12; 6" DOCK SPIKE IN SOUTHWEST OF NORTH SIDE SERVICE RD NORTH SIDE OF EAST GRAND BLVD WEST END OF BRIDGE EAST OF ENTRANCE TO DETROIT ENERGY RECYCLING NORTHING: 10109.6510 EASTING: 19962.6540 N 18° W BACK OF SIDEWALK 2.50 FT S 18° E BACK OF CURB 5.20 FT S 75° W CORNER POST FOR GATE 40.80 FT	

WITNESSES	
WITNESSES TO CP5; 6" DOCK SPIKE IN CROSS SEAM OF SIDEWALK EAST SIDE GENERAL MOTOR BLVD EAST END OF SITE SOUTH OF BRIDGE N 35° W SOUTHWEST ANCHOR BOLT OF LIGHT POLE 50.30 FT S 57° W CENTER WATER MANHOLE 26.35 FT S 76° W BACK OF CURB 7.35 FT NORTHING: 10328.3620 EASTING: 21655.7850	
WITNESSES TO CP6; 6" DOCK SPIKE IN CROSS SEAM OF SIDEWALK EAST SIDE OF GENERAL MOTOR BLVD EAST END OF SITE NORTH OF BRIDGE N 27° W SOUTHWEST ANCHOR BOLT OF LIGHT POLE 58.75 FT S 18° W CENTER LIGHT POLE 42.35 FT S 76° W BACK OF CURB 7.20 FT NORTHING: 10518.8810 EASTING: 21605.4040	

EXISTING STRUCTURE
THE EXISTING STRUCTURE IS A SIX SPAN BRIDGE WITH A TOTAL LENGTH OF 488'. THE EXISTING BEAMS ARE ROLLED STEEL BEAMS. THE SUBSTRUCTURE IS ON SPREAD FOOTINGS. THE BRIDGE WAS BUILT IN 1973.

UTILITIES	
CITY OF DETROIT, PUBLIC LIGHTING DEPT (PLD) 9449 GRINNELL DETROIT, MI 48213 ATTN: STAN TOPOLEWSKI PHONE NO.: (313) 267-7228	ELECTRIC, LIGHTING
CITY OF DETROIT DETROIT WATER & SEWERAGE DEPT (DWSD) J MADISON BLDG 1420 WASHINGTON BLVD., SUITE 100 DETROIT, MI 48226 ATTN: BHARAT DOSHI PHONE NO.: (313) 967-1541	WATER, SEWER
DTE ENERGY MICHIGAN CONSOLIDATED GAS CO. (MCG) 3200 HOBSON STREET DETROIT, MI 48201 ATTN: ADOLFO CASTILLO PHONE NO.: (313) 577-7470	GAS
DETROIT EDISON (DET ED) 982 BROADWAY ANN ARBOR, MI 48105-1804 ATTN: DENNIS BREWER PHONE NO.: (734) 332-3105	ELECTRIC
AT&T 31100 PLYMOUTH ROAD, ROOM 301 LIVONIA, MI 48150 ATTN: GARY CLINTON PHONE NO.: (734) 523-6880	PHONE
ITC HOLDINGS CORPORATION 27175 ENERGY WAY NOVI, MI 48377 ATTN: ERIN KEELER PHONE NO.: (248) 946-3298	ELECTRIC

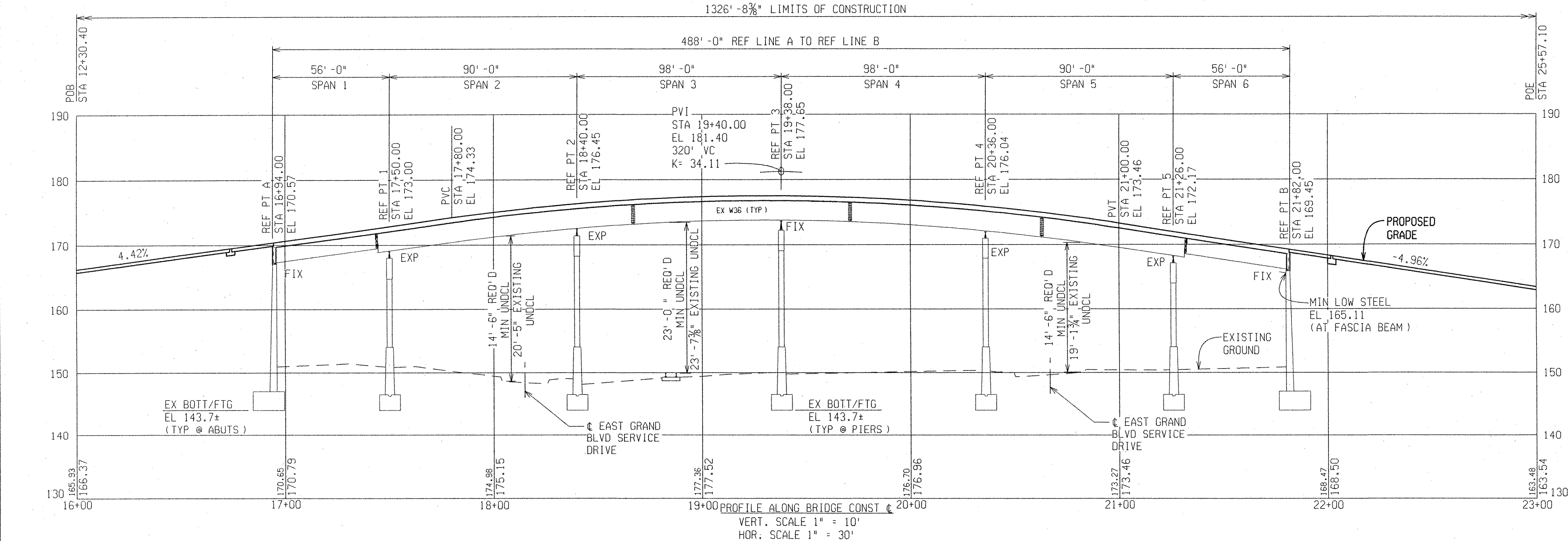
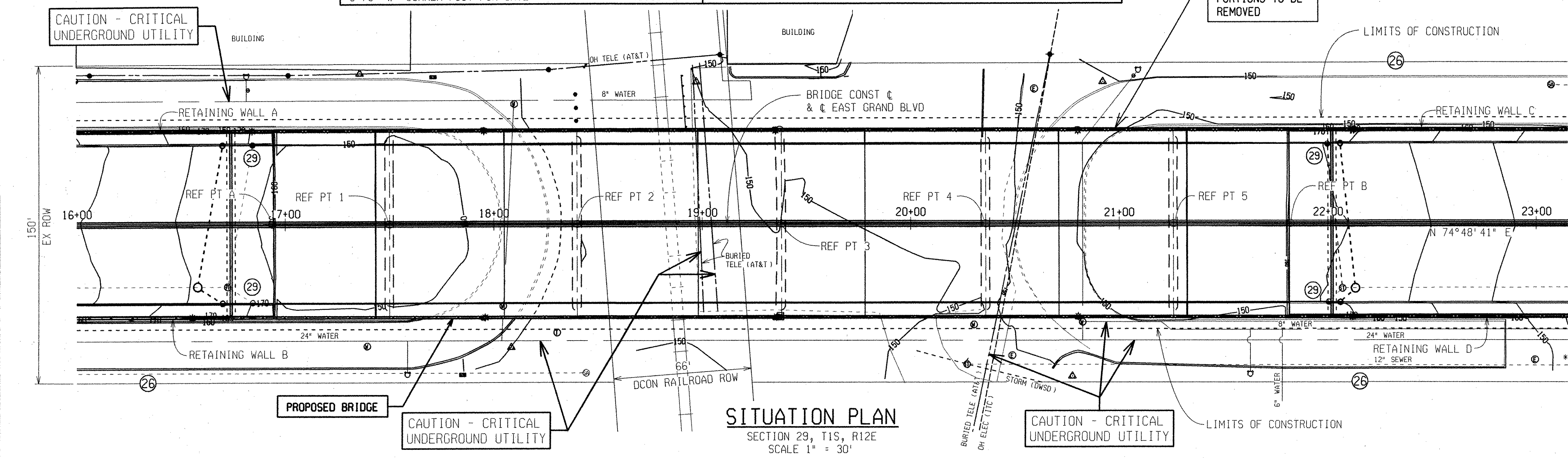

EROSION AND SEDIMENTATION CONTROL MEASURES		
		KEY NO.
1410	Ft Erosion Control, Silt Fence	28
6	Ea Erosion Control, Inlet Protection Fabric Drop	29
13	Ea Erosion Control, Inlet Protection, Geotextile and Stone	30

* PLACE AS DIRECTED BY THE ENGINEER

NOTES:
THE WORK COVERED BY THESE PLANS INCLUDES MAINTAINING TRAFFIC, REMOVAL AND REPLACEMENT OF THE BRIDGE DECK, PIN AND HANGER REPLACEMENT, SUBSTRUCTURE REPAIRS AND CONCRETE APPROACHES.
THE CONTRACTOR SHALL LOCATE ALL ACTIVE UNDERGROUND UTILITIES PRIOR TO STARTING WORK AND SHALL CONDUCT HIS OPERATIONS IN SUCH A MANNER AS TO ENSURE THAT THOSE UTILITIES NOT REQUIRING RELOCATION WILL NOT BE DISTURBED.
EAST GRAND BLVD TRAFFIC IS TO BE DETOURED OVER OTHER ROADS.
PLAN ELEVATIONS REFER TO CITY OF DETROIT DATUM.
THE TRAIN MOVEMENT AND SPEED INFORMATION SHOWN IN THE PROPOSAL DOES NOT REPRESENT A COMMITMENT BY THE DETROIT CONNECTING RAILROAD COMPANY AND IS SUBJECT TO CHANGE WITHOUT NOTICE.
MEASURES SHALL BE TAKEN TO PREVENT DEBRIS FROM FALLING FROM THE STRUCTURE.
ANY DAMAGE TO THOSE PORTIONS OF THE EXISTING STRUCTURE TO REMAIN IN PLACE RESULTING FROM THE CONTRACTOR'S ACTIONS SHALL BE REPAIRED OR REPLACED AS DIRECTED BY THE ENGINEER AND AT THE CONTRACTOR'S EXPENSE.

REVISIONS	DESCRIPTION	DATE	BY



EAST GRAND BLVD OVER
DETROIT CONNECTING RAILROAD
MDOT JOB NO. 86173A STRUCTURE NO. R01 of 82-22-54

GENERAL PLAN OF SITE

DATE: 04/16/08
DLZ JOB NO. 0642-6090-00
SHEET NO. 4 OF 60

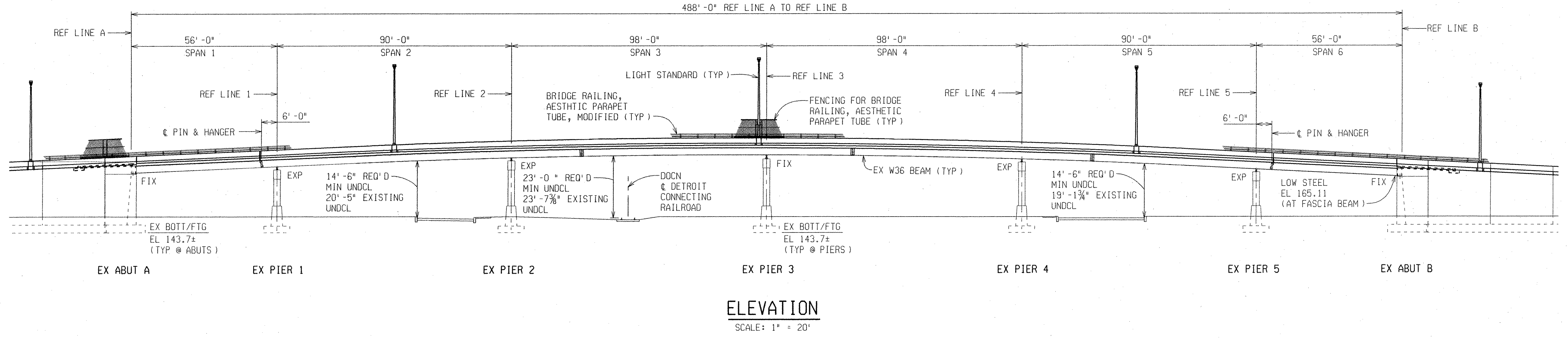
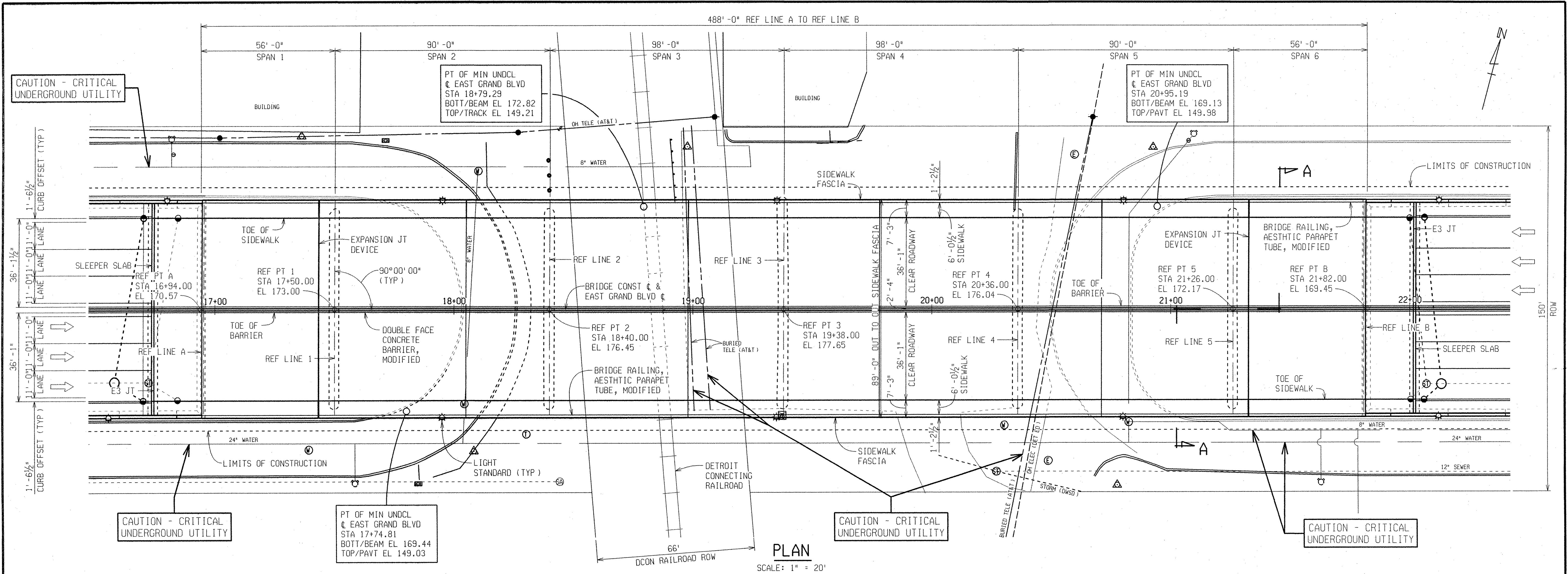

REVISIONS	DESCRIPTION	DATE	BY

DLZ	CITY OF DETROIT	EAST GRAND BLVD OVER DETROIT CONNECTING RAILROAD	GENERAL PLAN OF STRUCTURE
		MDOT JOB NO. 86173A	STRUCTURE NO. R01 of 82-22-54

DATE: 04/16/08
DLZ JOB NO. 0642-6090-00
SHEET NO. 5 OF 60

DATE: 1/8/07
 CORRECTED BY: DAF
 DATE: 1/7/07
 CHECKED BY: KCK
 DATE: 1/10/07
 DRAWN BY: DAF
 FILE NAME: east grand st1.dgn

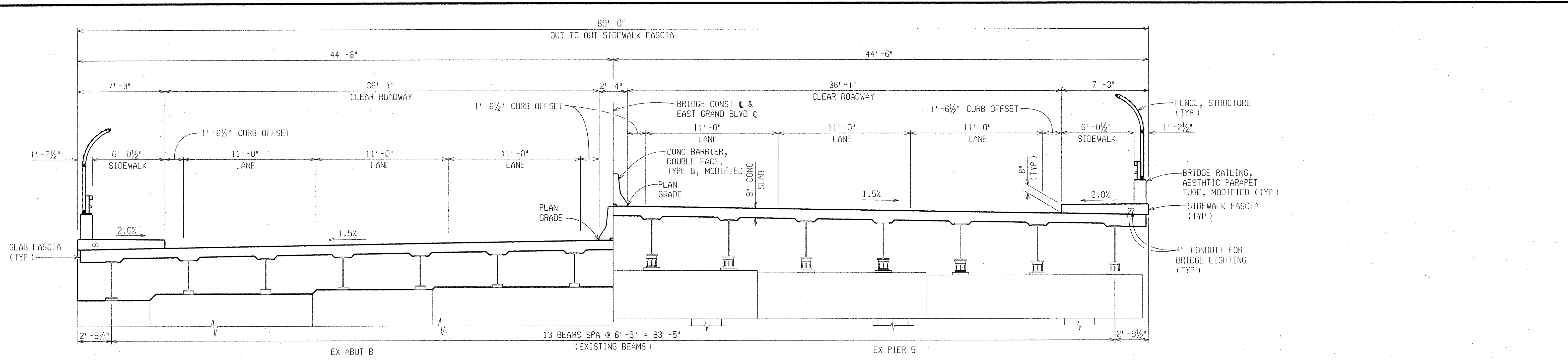

SECTION A-A

NOTE: FOR THE LIMITS OF APPROACH RECONSTRUCTION SEE SHEET 17 AND 18 OF 18.

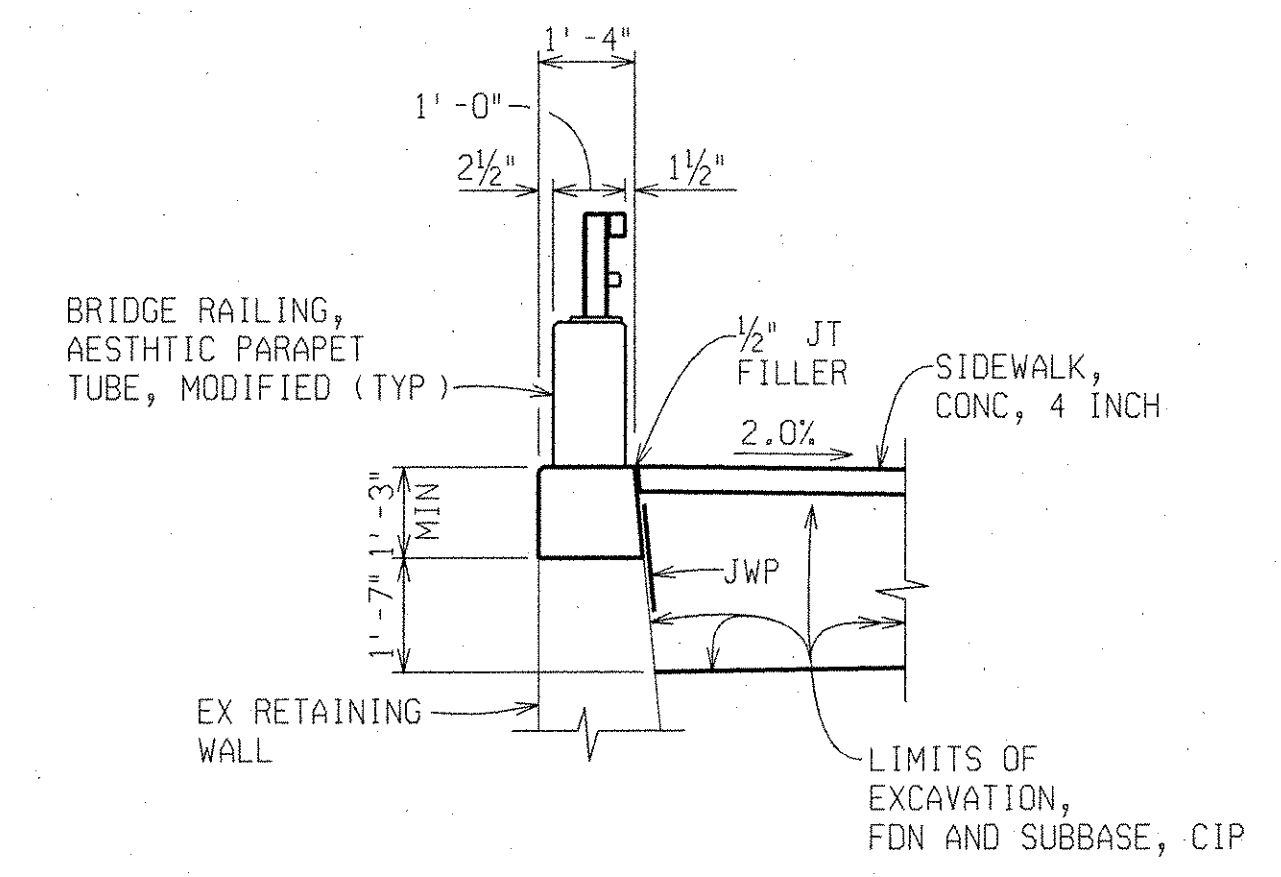
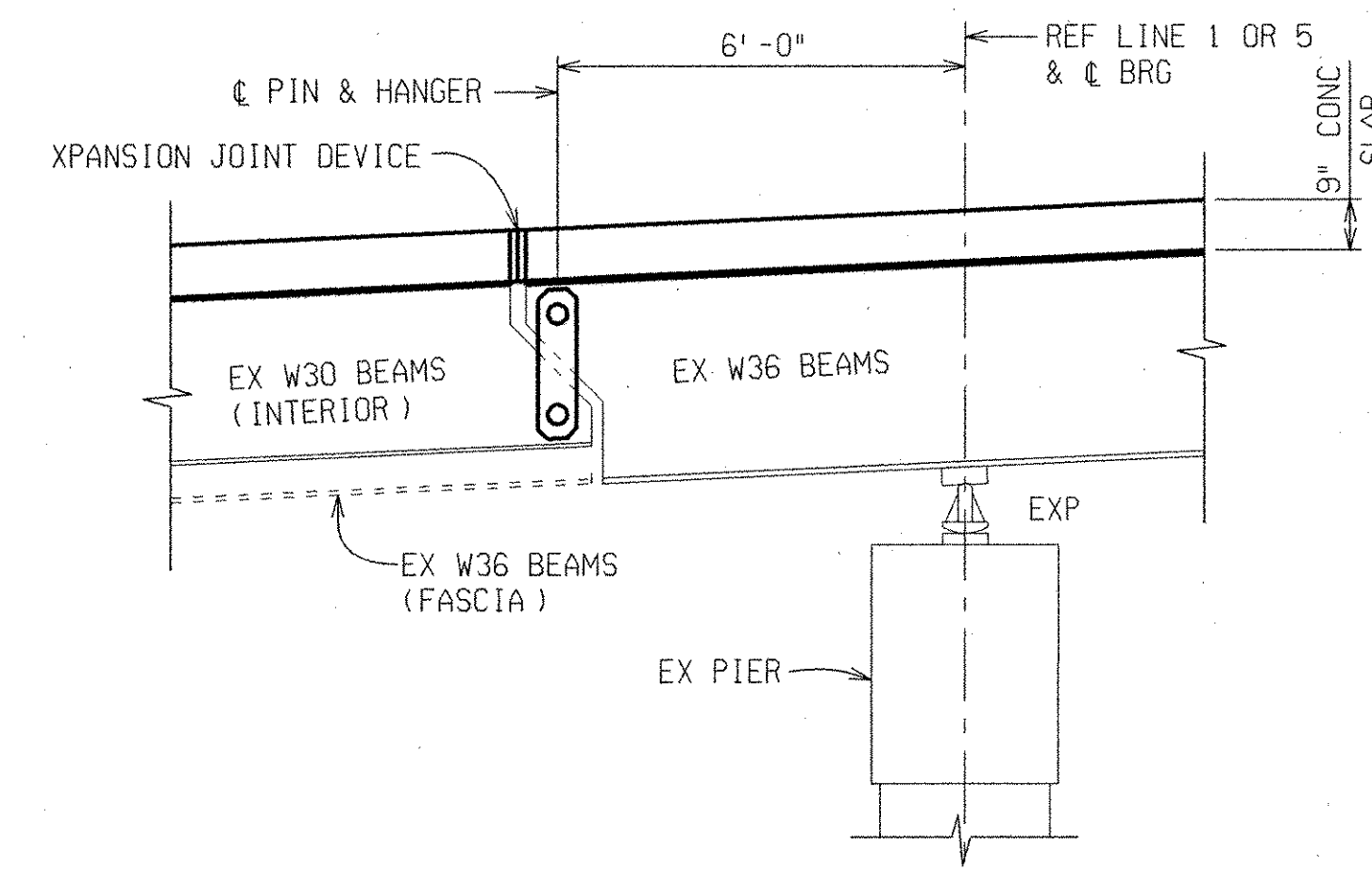
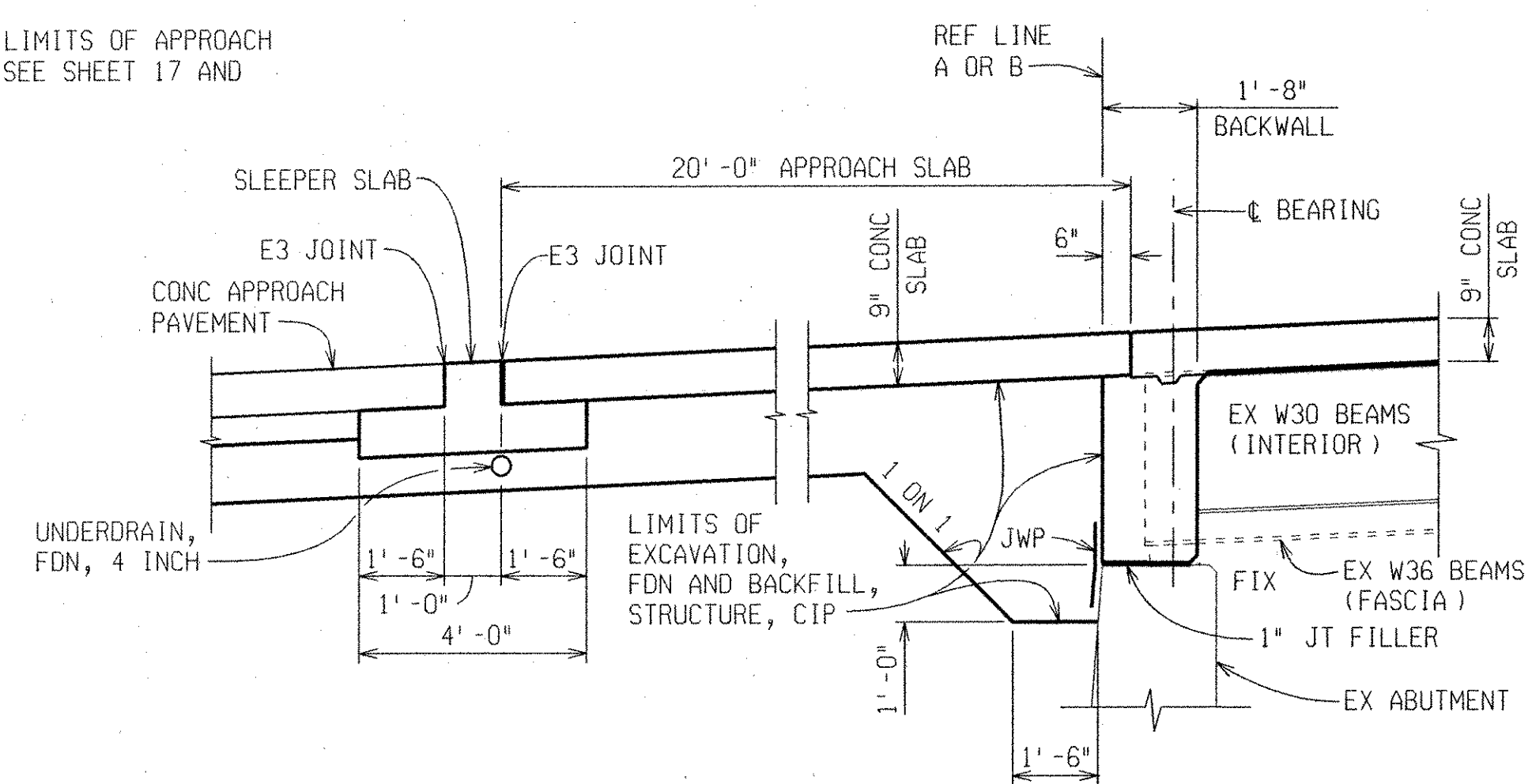

MISCELLANEOUS QUANTITIES		
976	Ft	Fence, Rem
1	LS	Structures, Rem Portions (R01 of 82-22-52)
186	Cyd	Backfill, Structure, CIP
98	Cyd	Excavation, Fdn
40,710	Sft	False Decking
2661	Sft	Joint Waterproofing
211,500	Dollar	Railroad Inspection and Flagging
6	Ea	Hh Cover
976	Ft	Conduit, Encased, 2, 4 Inch
30	Ft	Conduit, Encased, 1, 3 Inch

NOTES:

THE REHABILITATION DESIGN IS BASED ON CURRENT AASHTO STANDARD SPECIFICATIONS FOR HIGHWAY BRIDGES HS20-44 LOADING. LIVE LOAD PLUS IMPACT DEFLECTION DOES NOT EXCEED 1/1000 OF SPAN LENGTH AND 1/375 OF CANTILEVER ARM. THE LOAD FACTOR METHOD OF DESIGN WAS USED FOR THIS STRUCTURE. THE ORIGINAL STRUCTURE WAS DESIGNED FOR HS20-44 LOADING.

FALSE DECKING SHALL INCLUDE THE AREA BOUND BY REFERENCE LINES A & B AND OUTSIDE FLANGE OF FASCIA BEAMS. THE ESTIMATED AREA IS 40,710 SQUARE FEET DURING REMOVAL AND THE PROPOSED CONSTRUCTION.

LEGEND:

JWP DENOTES JOINT WATERPROOFING.

REVISIONS	DESCRIPTION	DATE	BY

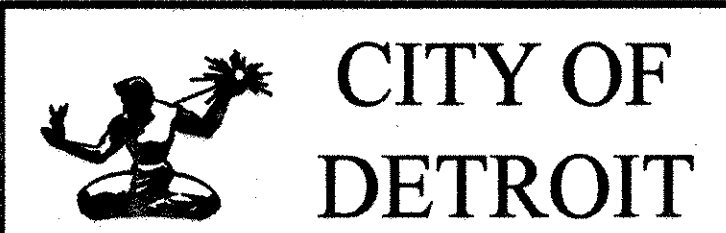

EAST GRAND BLVD OVER
DETROIT CONNECTING RAILROAD

MDOT JOB NO. 86173A STRUCTURE NO. R01 of 82-22-54

GENERAL PLAN OF STRUCTURE

DATE: 04/16/08
DLZ JOB NO. 0642-6090-00
SHEET NO. 6 OF 60

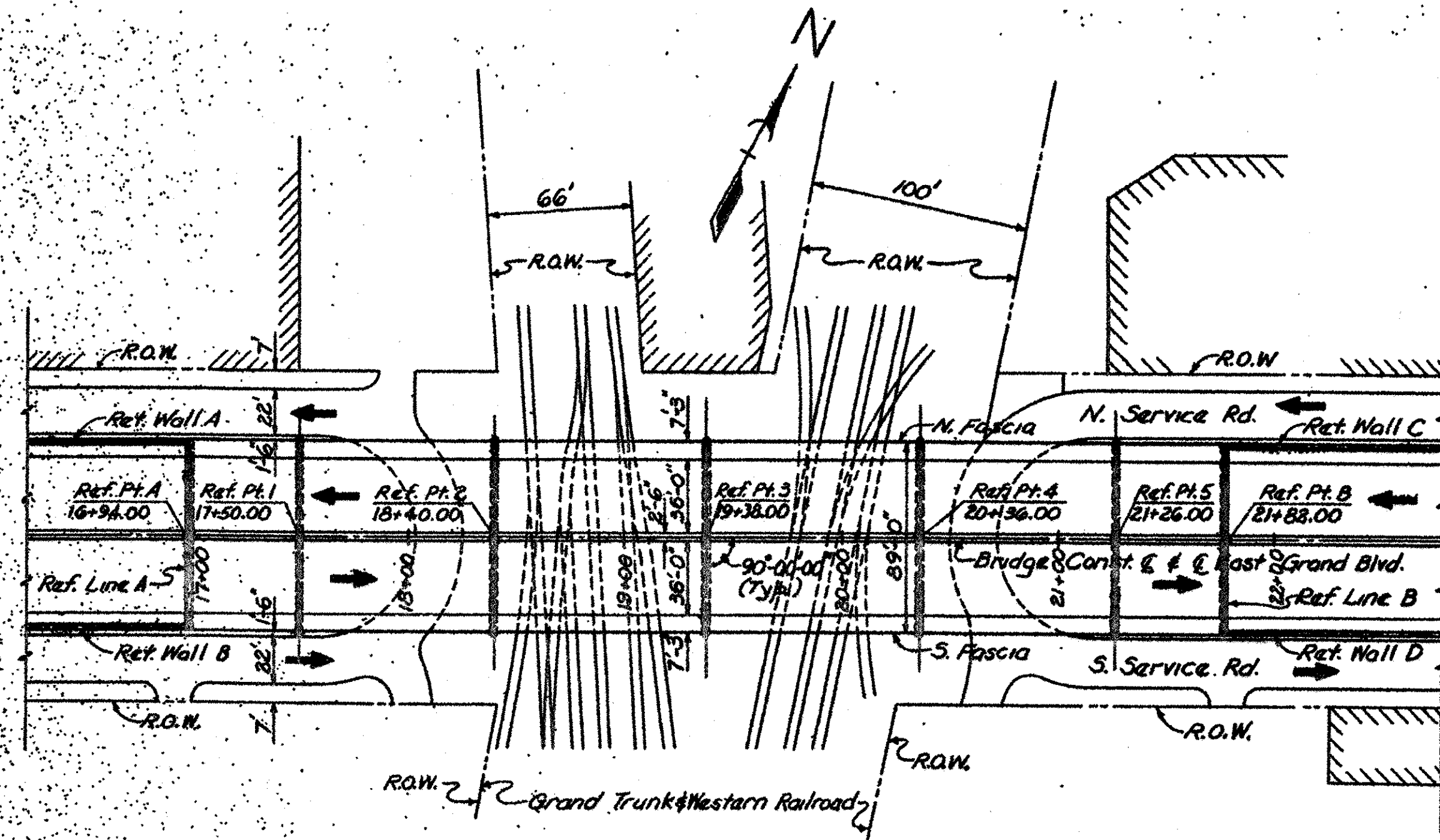

PLAN
Scale - 1" = 40'

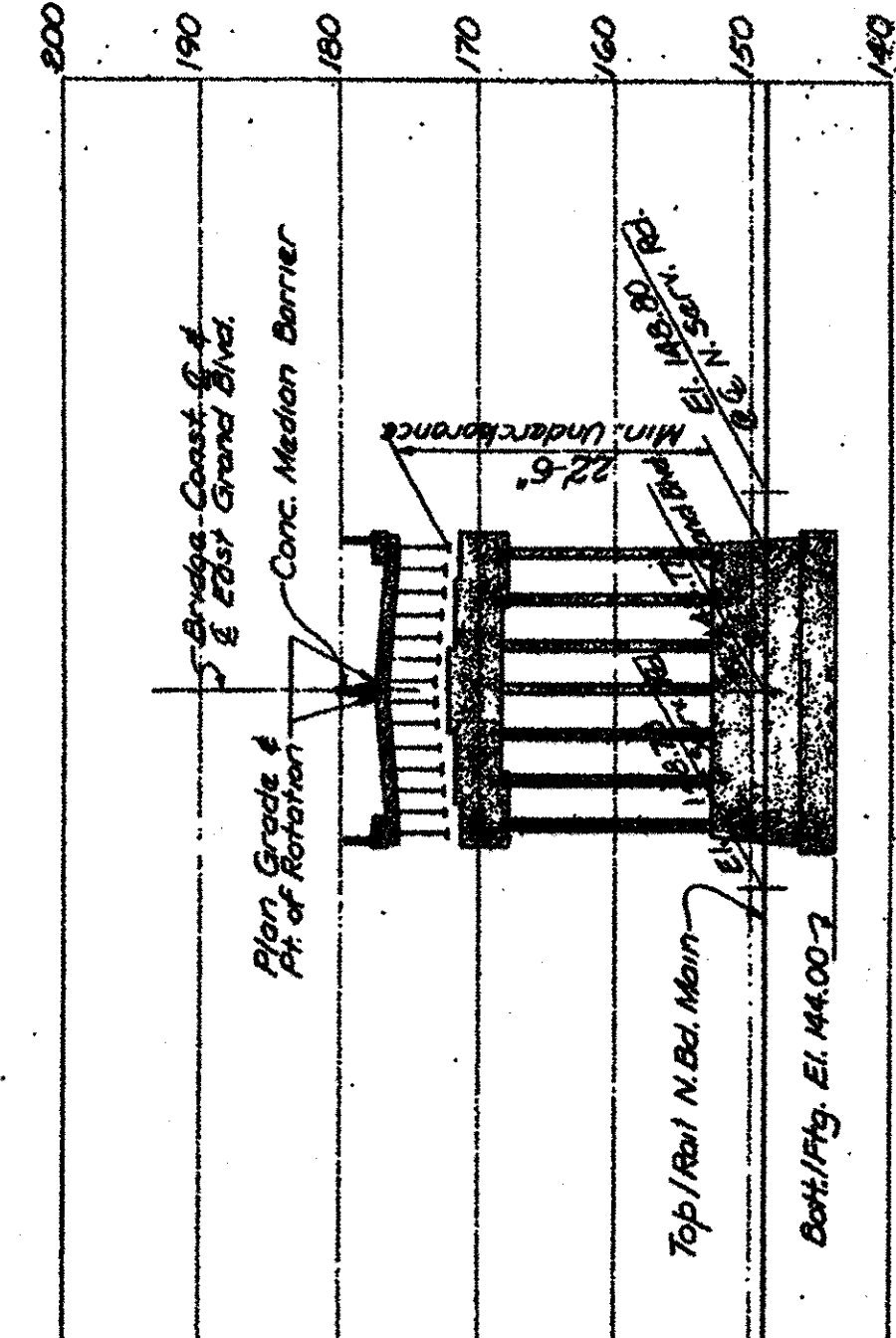

PROFILE - N. Bd. MAIN
Scale - Horiz. 1" = 40'
Vert. 1" = 10'

TRAIN MOVEMENT
Daily 7:00 A.M. to 7:00 P.M., 25 to 30
trains which includes 6 commuter
trains.

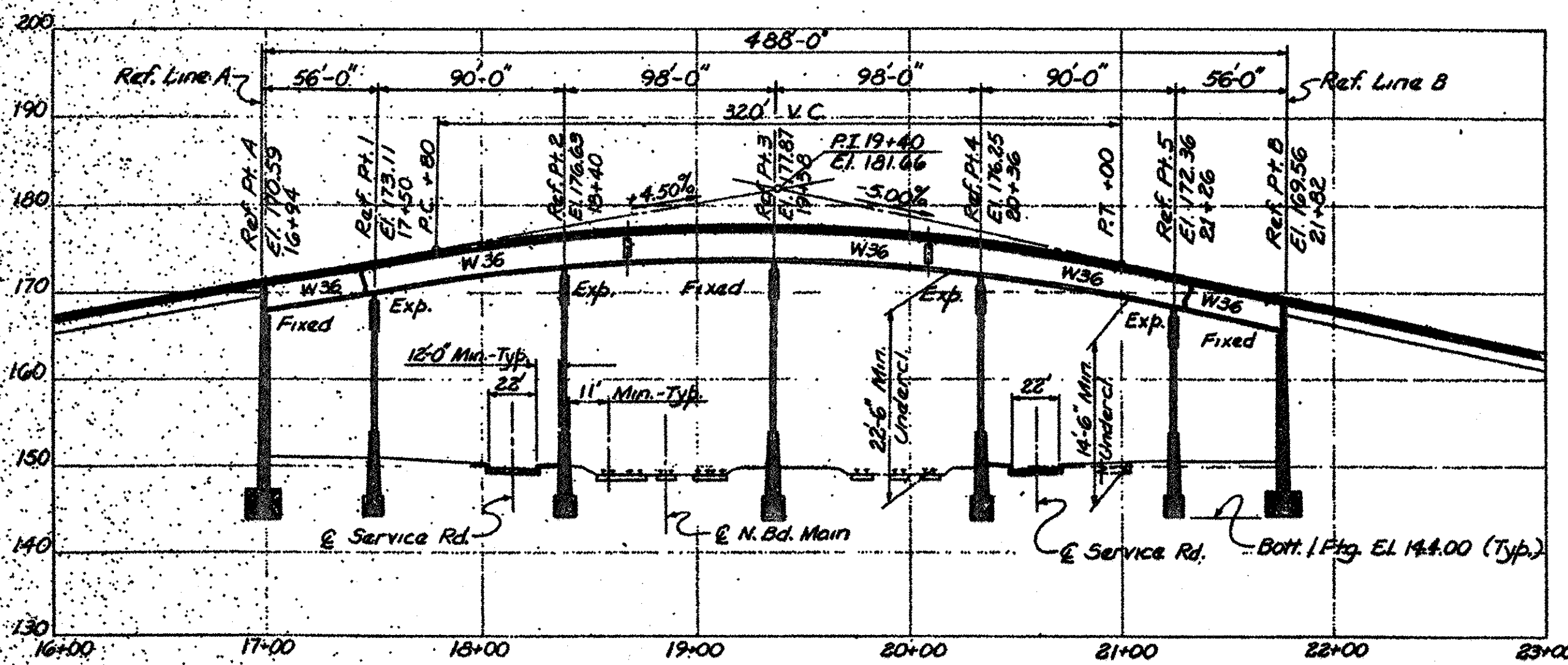

PROFILE
Scale - Horiz. 1" = 40'
Vert. 1" = 10'

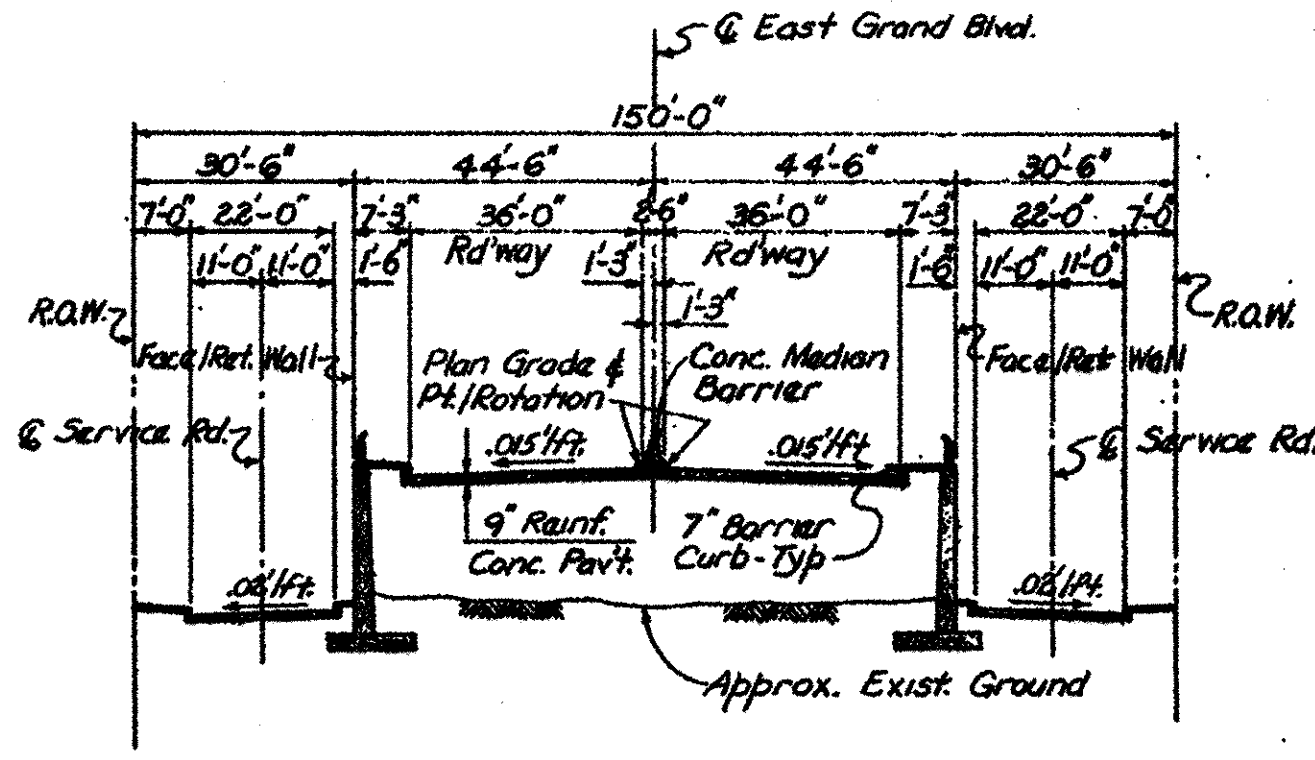

TYPICAL SECTION THRU APPROACH
Scale - 1" = 30'

GENERAL NOTES

The work covered by these plans include construction of the proposed bridge and retaining walls to the limits shown. All work not listed is included with the Road Plans.
For Bench Marks see survey Plan, Sh. #3, #4, & #5.
Datum refers to City of Detroit Datum. To obtain U.S.C&G.S. Precise Datum add 472.755'.
For maintenance of traffic see Road Plans.
Approximately 80% of the cost of this structure represents a hazard to railroad operations.
The information concerning train movement does not represent a commitment by the G.T.W.R.R. to continue them unchanged inasmuch as they are subject to change without notice.
The ground adjacent to the tracks and structure shall be graded by the road contractor to provide drainage.
The Contractor shall locate all active underground utilities prior to starting work and shall conduct his operations in such a manner as to insure that these utilities not requiring relocation will not be disturbed.

EXISTING
FOR INFORMATION ONLY
DO NOT WORK FROM THIS SHEET.
THE INFORMATION SHOWN HERE IS FOR REFERENCE ONLY. NO PAY ITEMS ARE SHOWN.

MASH Revision 5-1-77 REVISIONS NO. DATE BY 1 10/1/77 J.P. [unclear] 2 10/1/77 J.P. [unclear] 3 10/1/77 J.P. [unclear]		BOARD OF WAYNE COUNTY ROAD COMMISSIONERS DETROIT, MICHIGAN PHILIP J. HELMREICH		T4000(3) PROJECT 508 SHEET NO. 2 DATE 5-7-78	
--	--	--	--	---	--

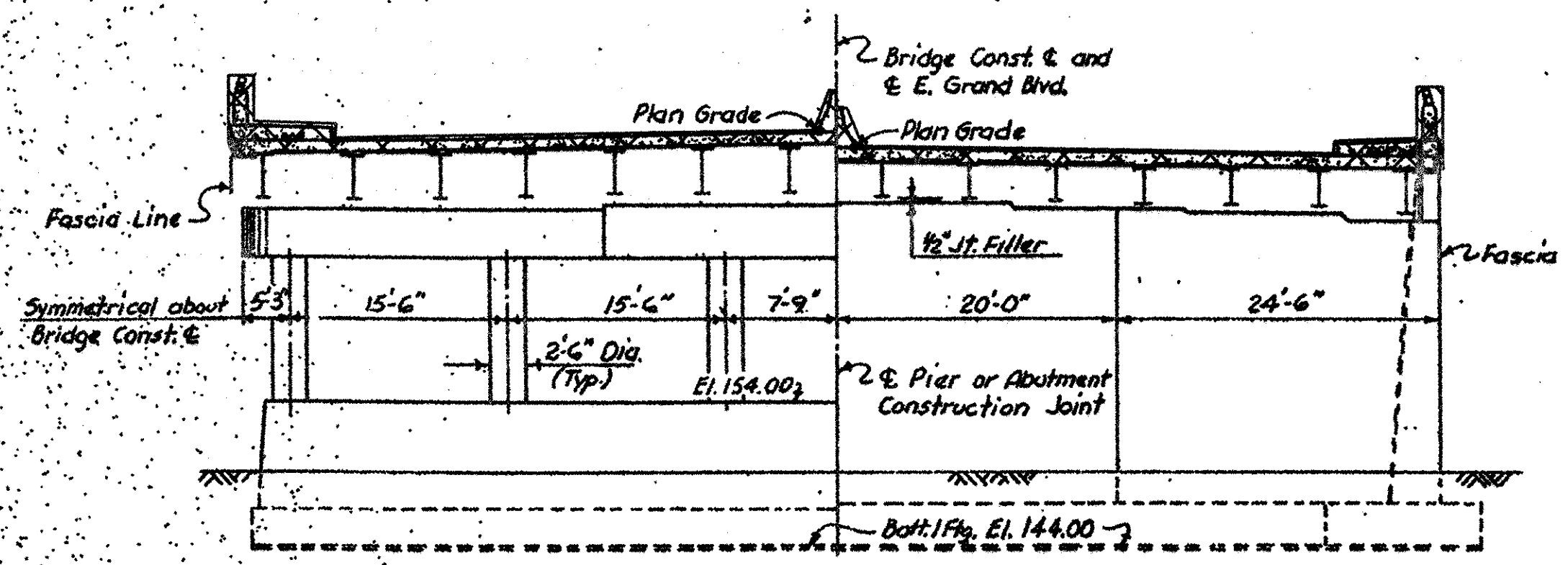

ELEVATION
Scale - 1/8" = 1'-0"

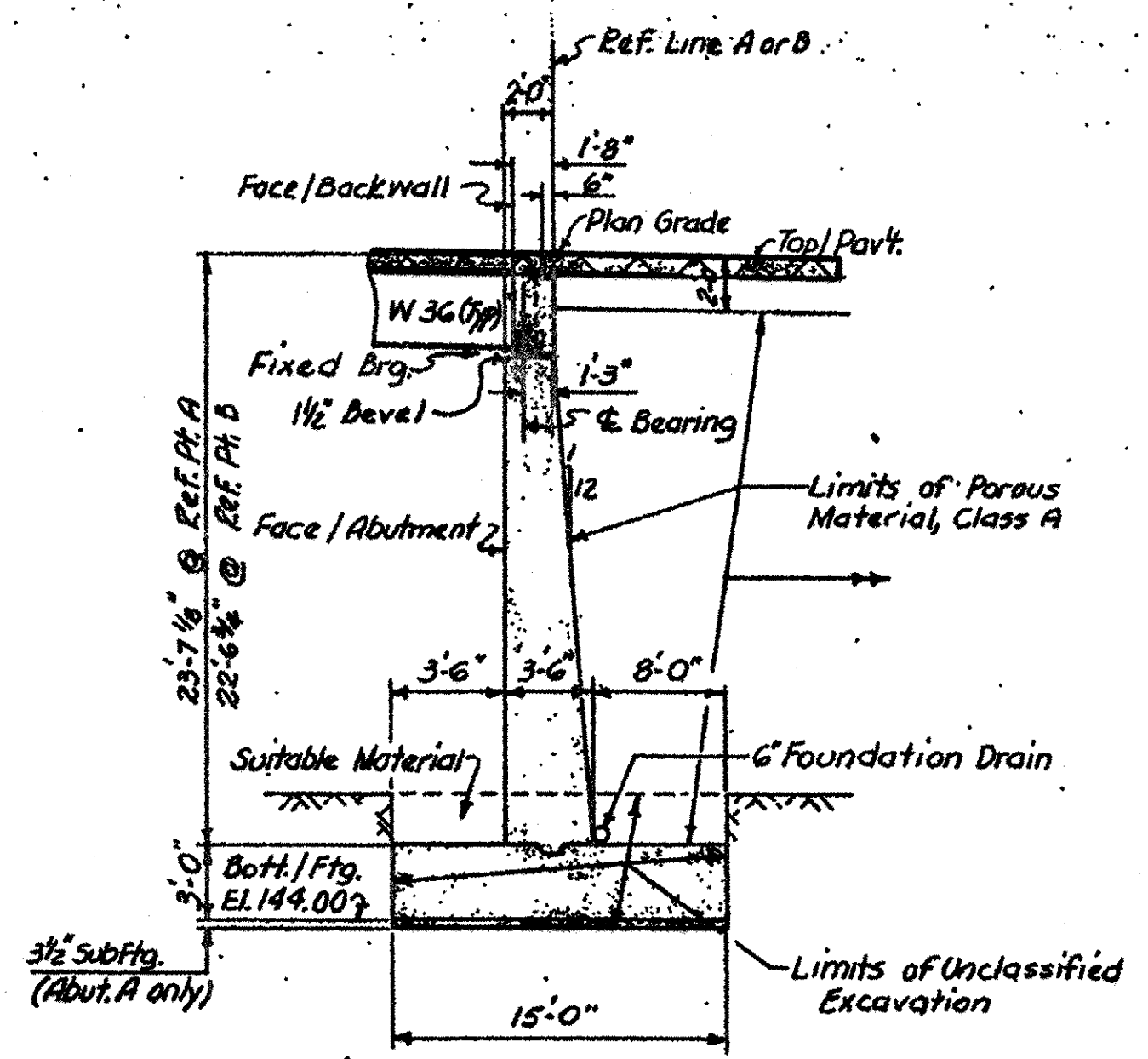

ABUTMENT SECTION
Scale - 1/8" = 1'-0"

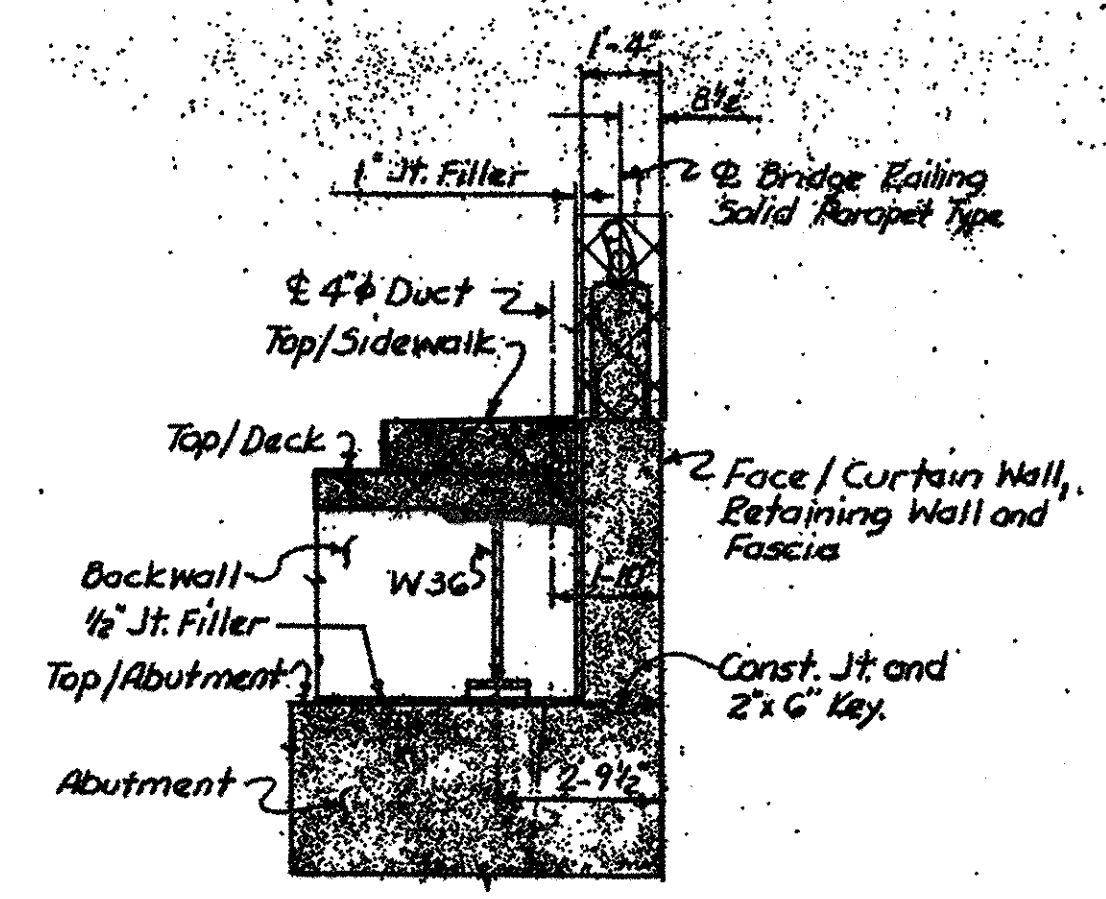

SECTION A-A
Scale - 3/8" = 1'-0"

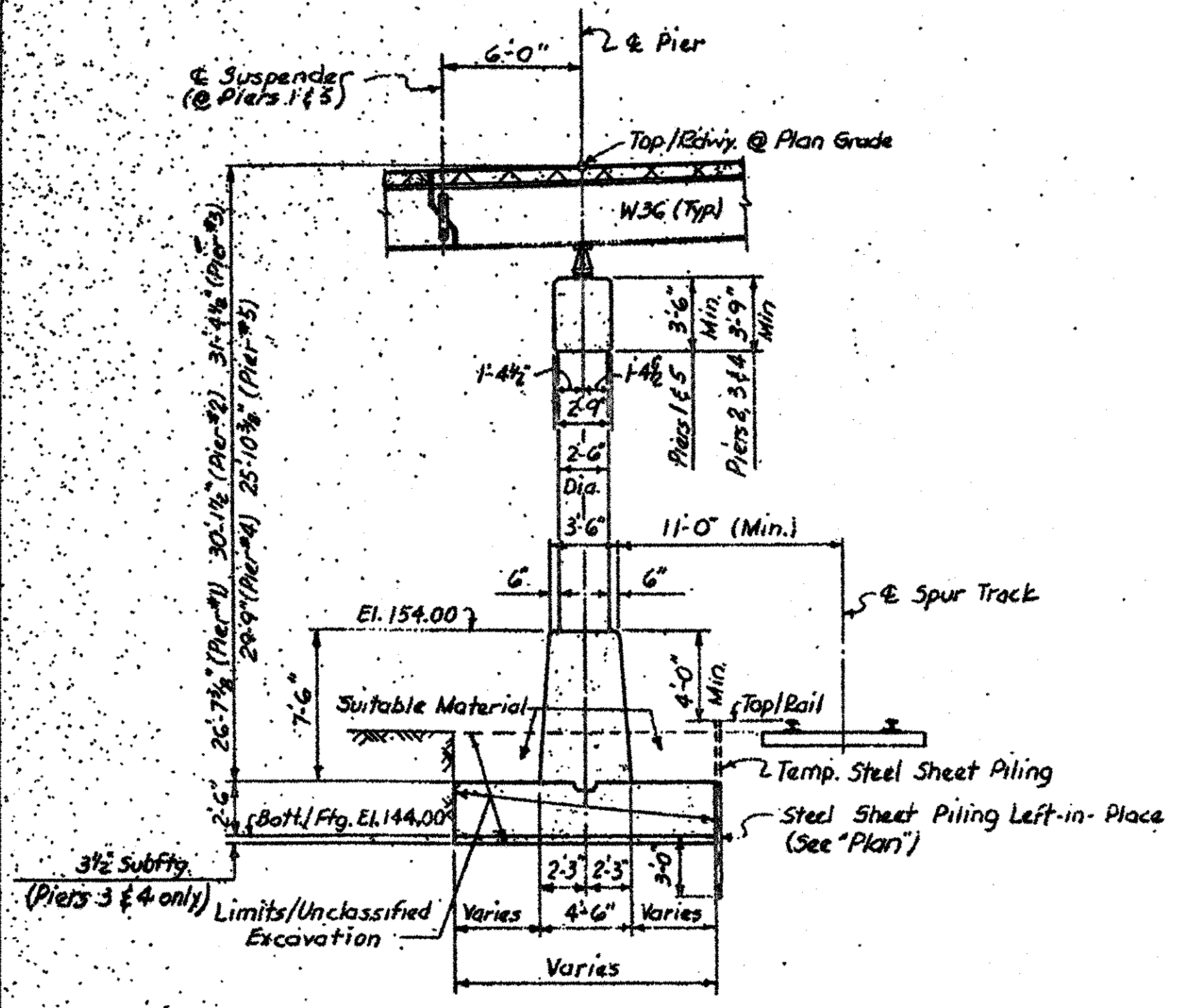

PIER SECTION
Scale - 3/16" = 1'-0"

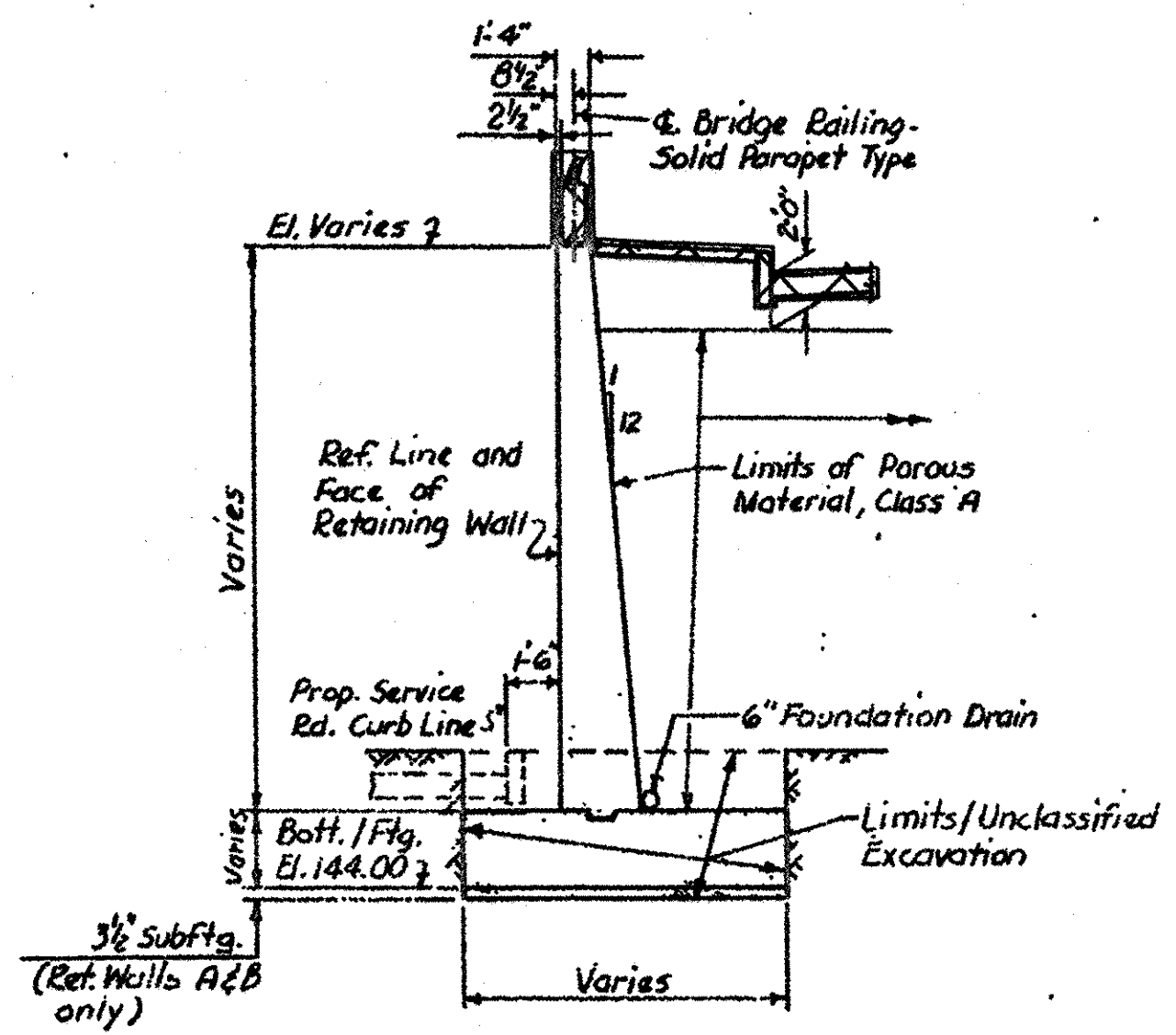

RETAINING WALL SECTION
Scale - 3/16" = 1'-0"

REMOVAL SHEET

JOB NUMBER 86173A
THE ONLY ITEMS OF WORK TO BE DONE FROM THIS SHEET ARE IDENTIFIED BY THE LEGEND BOX BELOW, LABELED WITH THIS PROJECT'S JOB NUMBER.
[] PROPOSED WORK
[X] DENOTES REMOVAL PORTIONS

MISCELLANEOUS QUANTITIES		
Item	Unit	Amount
Unclassified Excavation	Cu. Yds.	5,710

Work this Sheet with Sh.# 7.

T4000(3)

REVISIONS	DESIGNED BY	CHECKED BY	DATE	CORRECT
	Hodkinson	E. PLATZ	9-28-71	

BOARD OF
WAYNE COUNTY ROAD COMMISSIONERS
DESIGN DIVISION

EAST GRAND BOULEVARD OVER GRAND TRUNK RAILROAD GRADE SEPARATION GENERAL PLAN OF STRUCT. (CONT'D)
COUNTY PROJECT: 508
SHEET NO.: 8
DATE: 4-3-72

F I I F

REVISIONS	DESCRIPTION	DATE	BY



EAST GRAND BLVD OVER DETROIT CONNECTING RAILROAD
MDOT JOB NO. 86173A STRUCTURE NO. R01 of 82-22-54

EX GENERAL PLAN OF STRUCTURE (REMOVAL)

DATE: 04/16/08
DLZ JOB NO. 0642-6090-00
SHEET NO. 9 OF 60

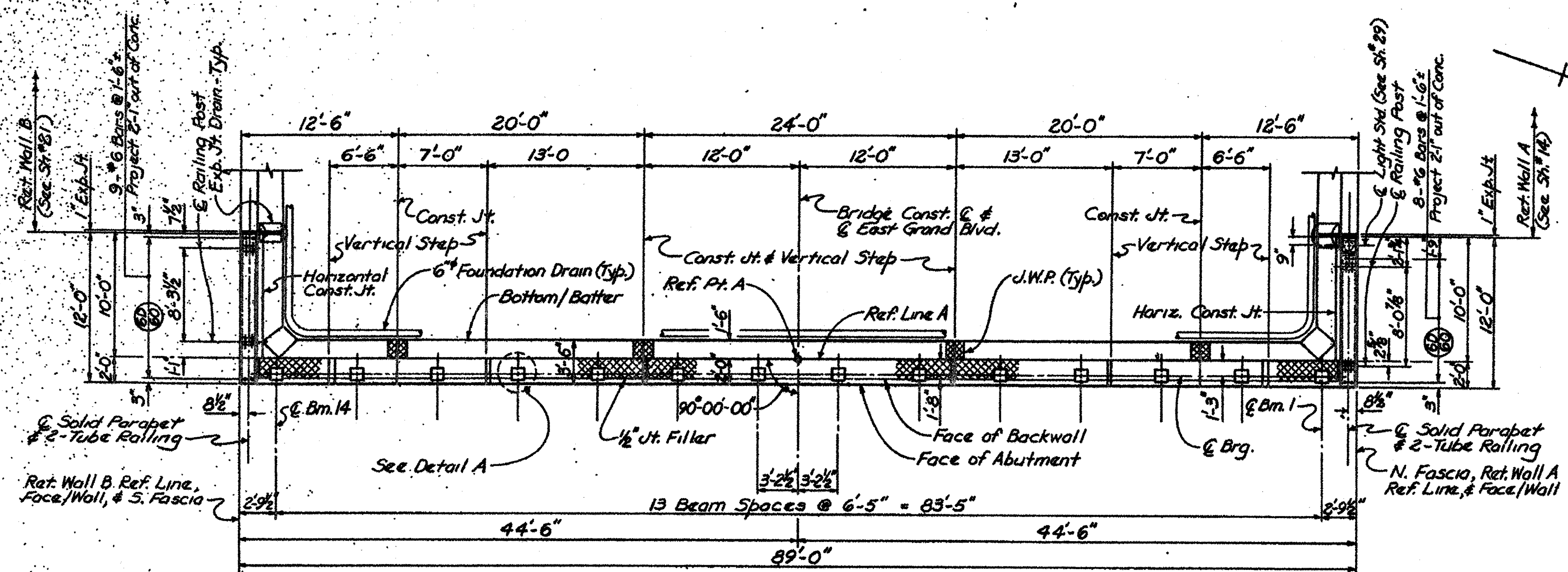

PLAN-ABOVE FOOTING

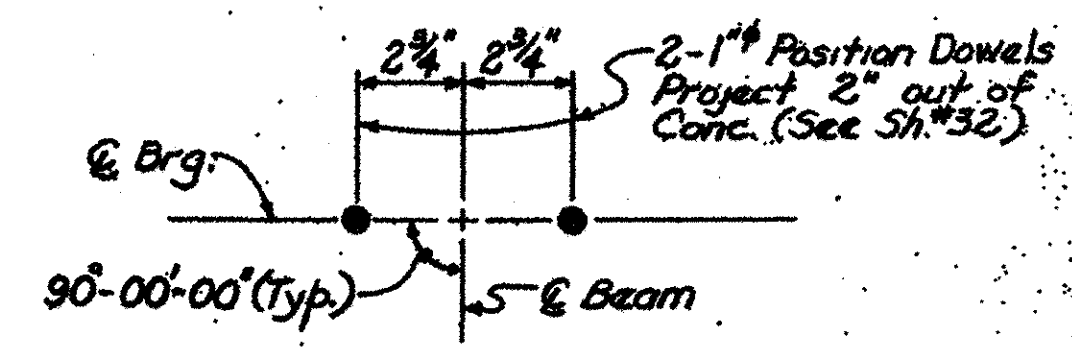

DETAIL A

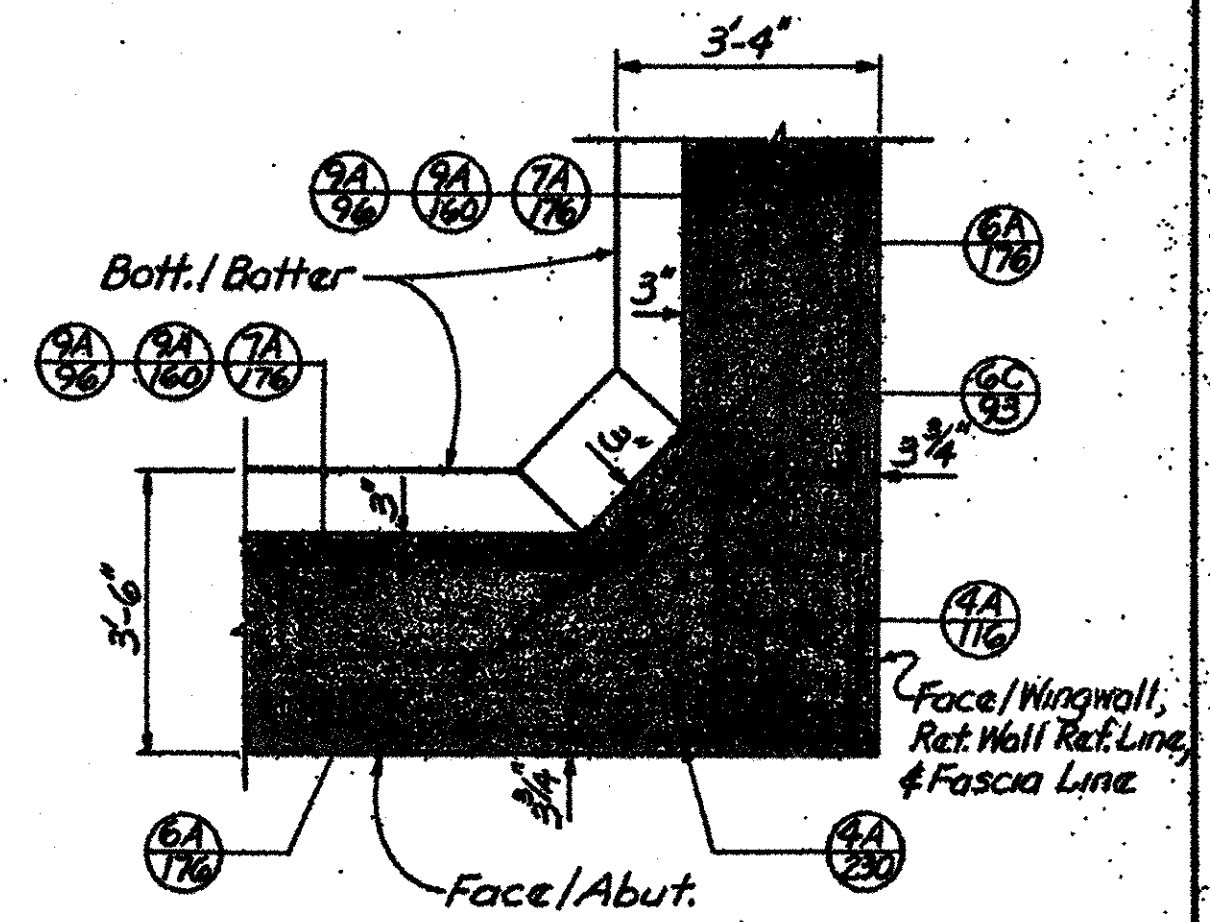

SECTION D-D

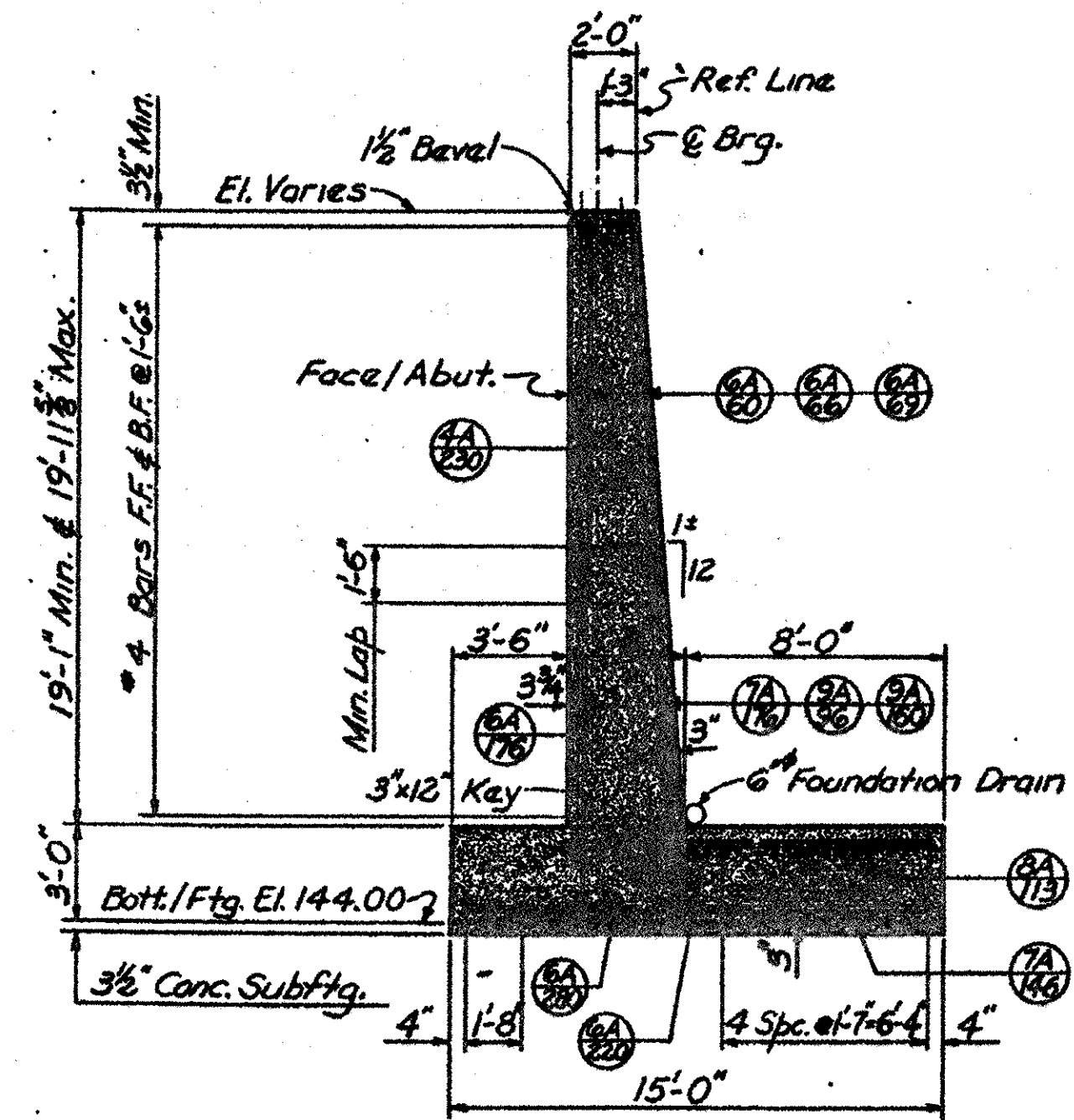

SECTION A-A

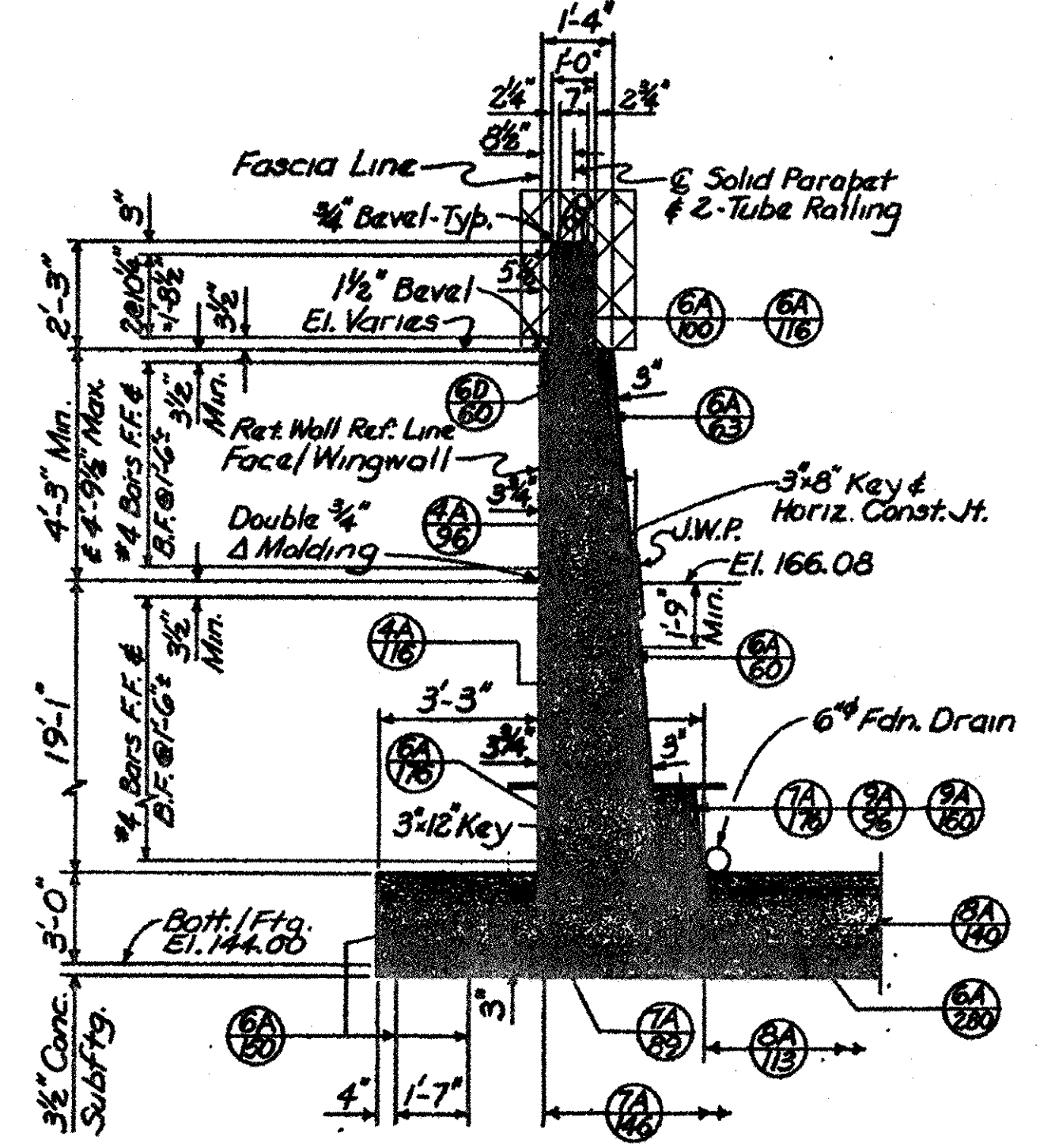

SECTION B-B

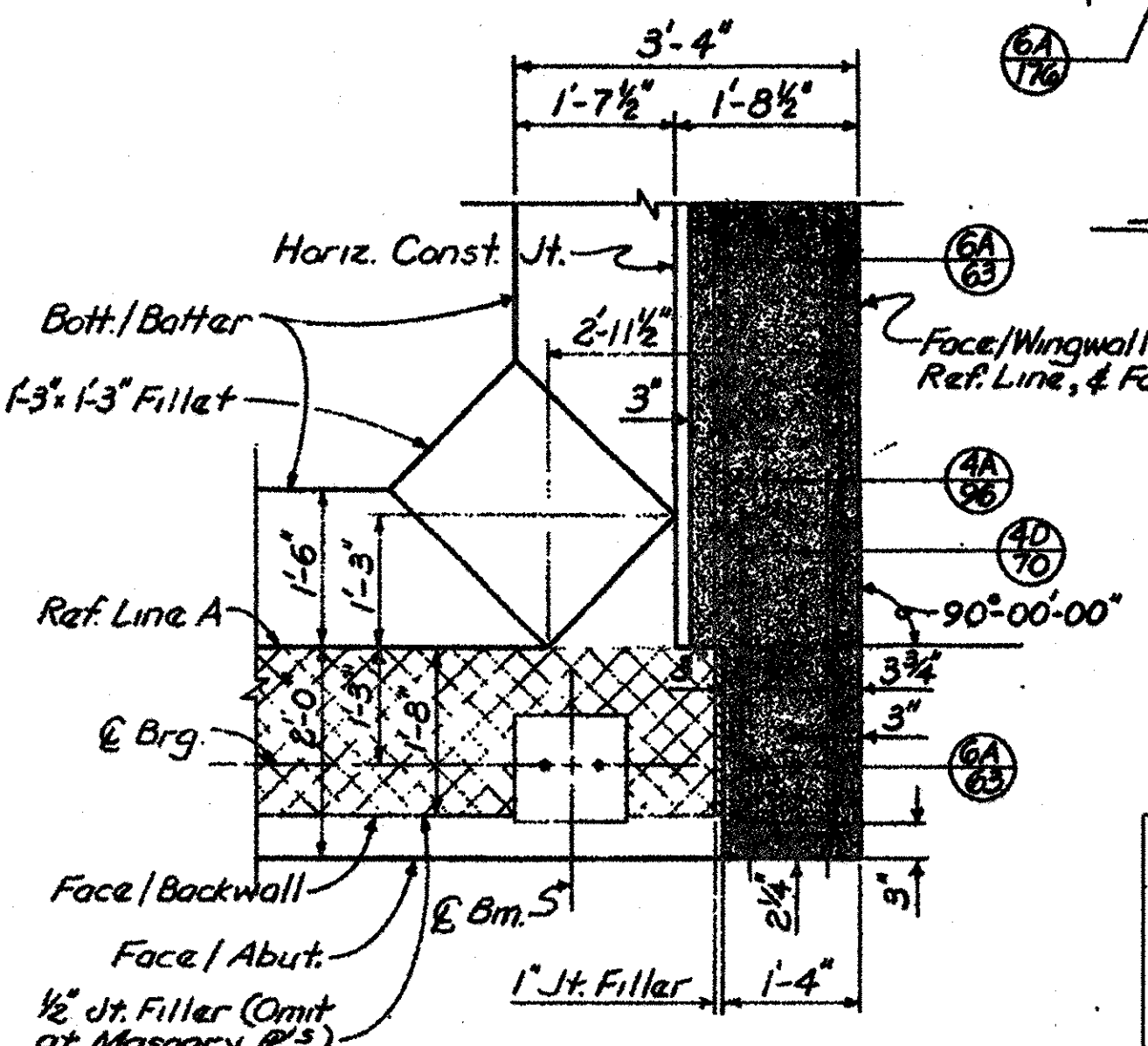

SECTION C-C

Note:
North Corner shown in Section C-C
& Section D-D. South Corner
similar but Opposite Hand.

REMOVAL SHEET

JOB NUMBER 86173A

THE ONLY ITEMS OF WORK TO BE DONE FROM THIS SHEET ARE IDENTIFIED BY THE LEGEND BOX BELOW, LABELED WITH THIS PROJECT'S JOB NUMBER.

PROPOSED WORK
 DENOTES REMOVAL PORTIONS

Work this Sheet with Sh. #11 & 29 T4000(3)

COUNTY PROJECT	508
COUNTY JOB	10
DATE	4-3-72

REVISIONS	DESIGNED BY	CHECKED BY	DATE	APPROVED
	E. PLATZ	C.D.K.	3-8-72	

BOARD OF COMMISSIONERS

WAYNE COUNTY ROAD COMMISSIONERS

DESIGN DIVISION

EAST GRAND BOULEVARD OVER GRAND TRUNK RAILROAD GRADE SEPARATION ABUTMENT A DETAILS

REVISIONS	DESCRIPTION	DATE	BY

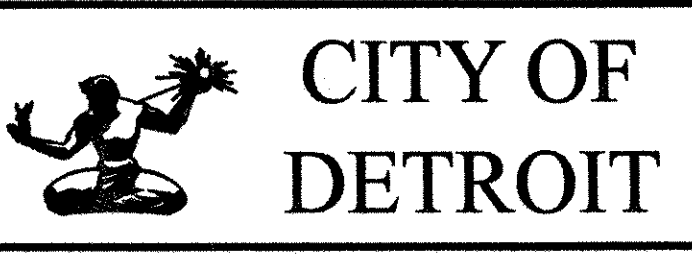

EAST GRAND BLVD OVER DETROIT CONNECTING RAILROAD

MDOT JOB NO. 86173A STRUCTURE NO. R01 of 82-22-54

EX ABUTMENT A DETAILS (REMOVAL)

DATE: 04/16/08

DLZ JOB NO. 0642-6090-00

SHEET NO. 10 OF 60

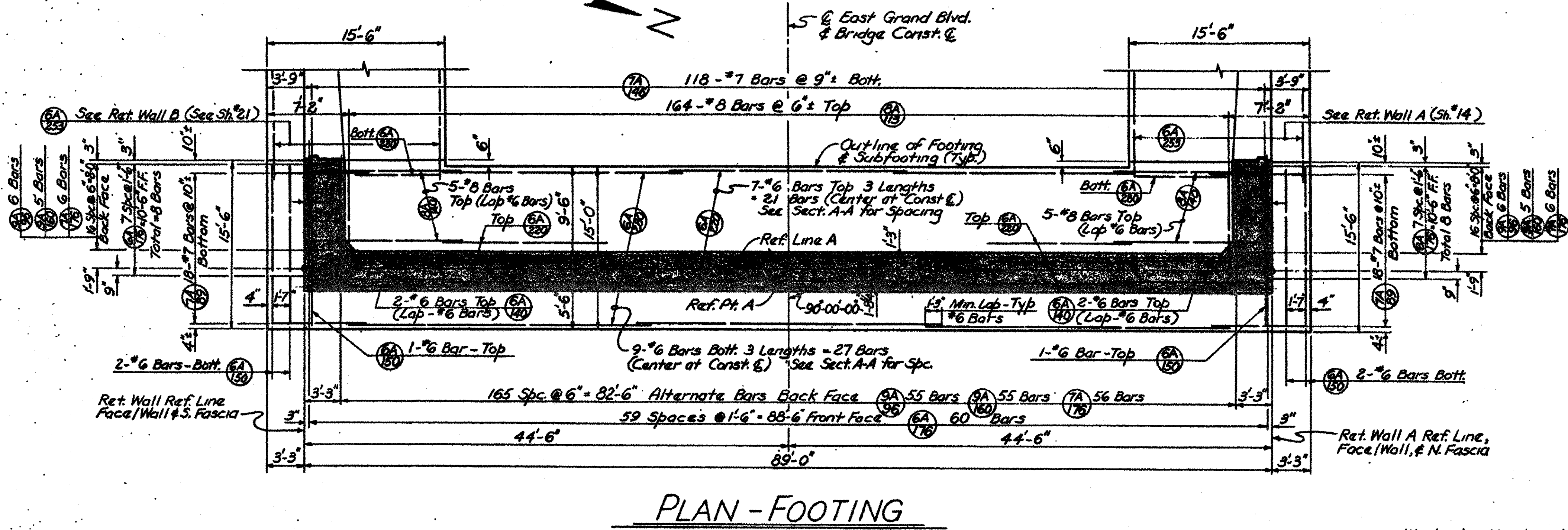
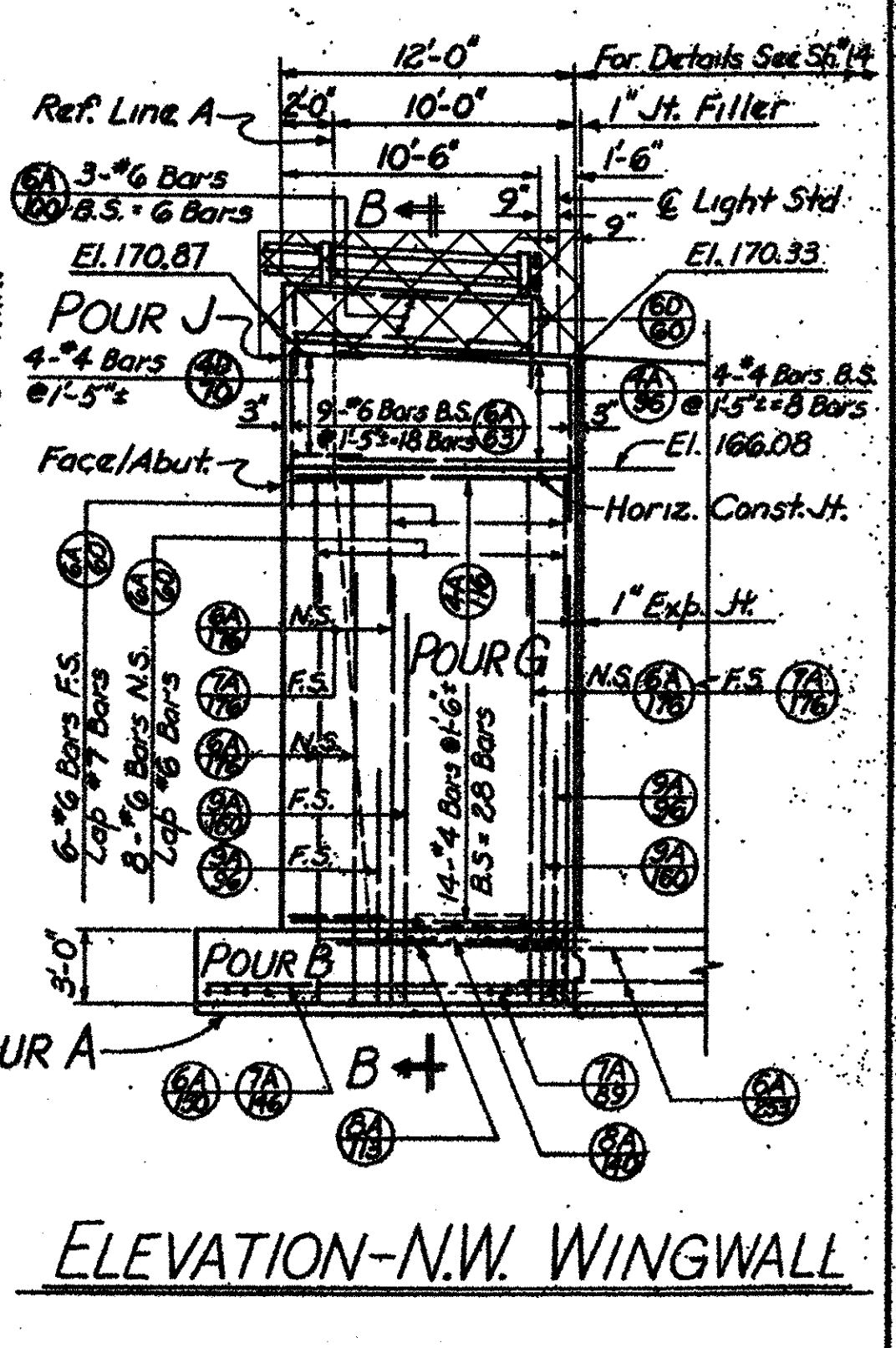
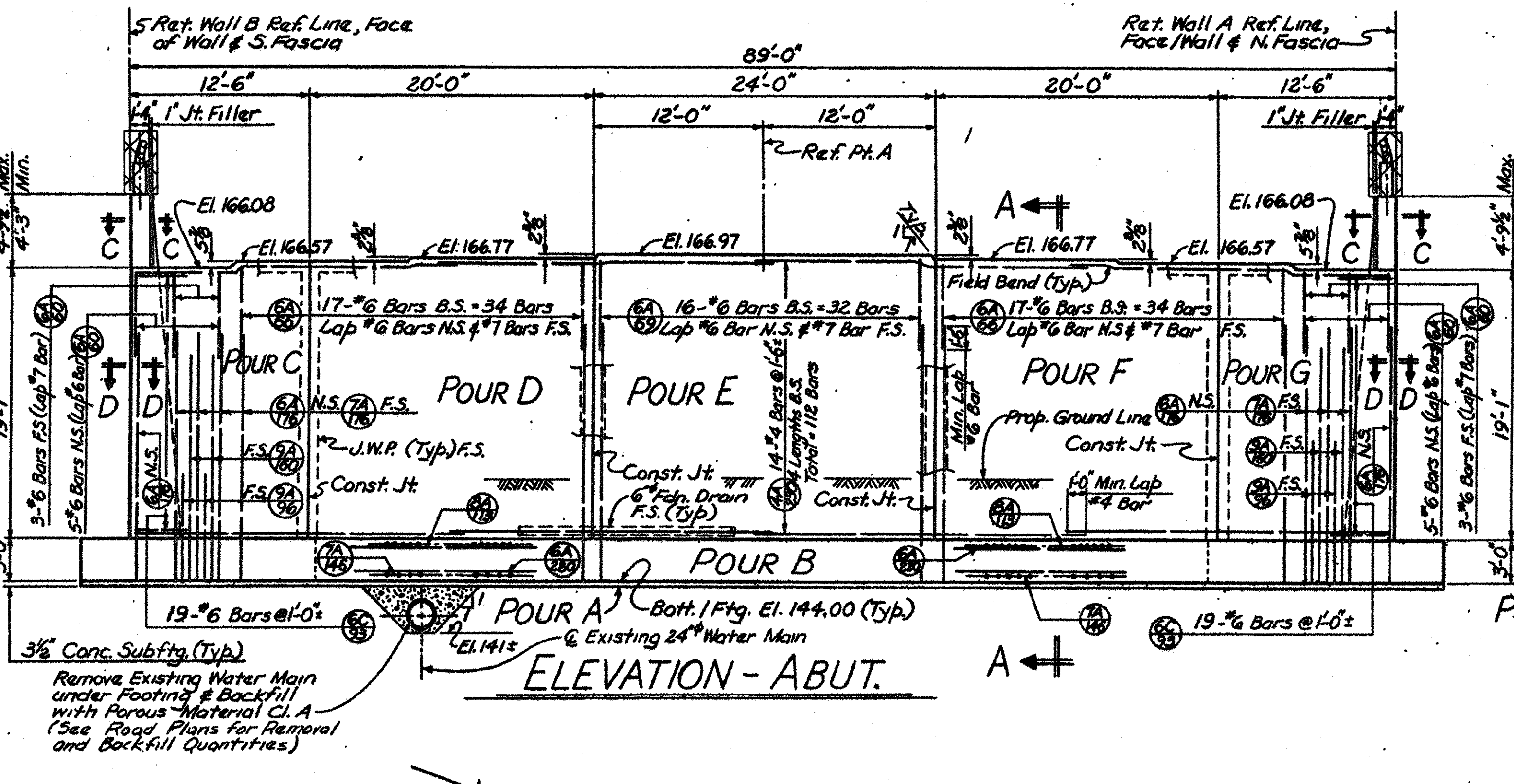
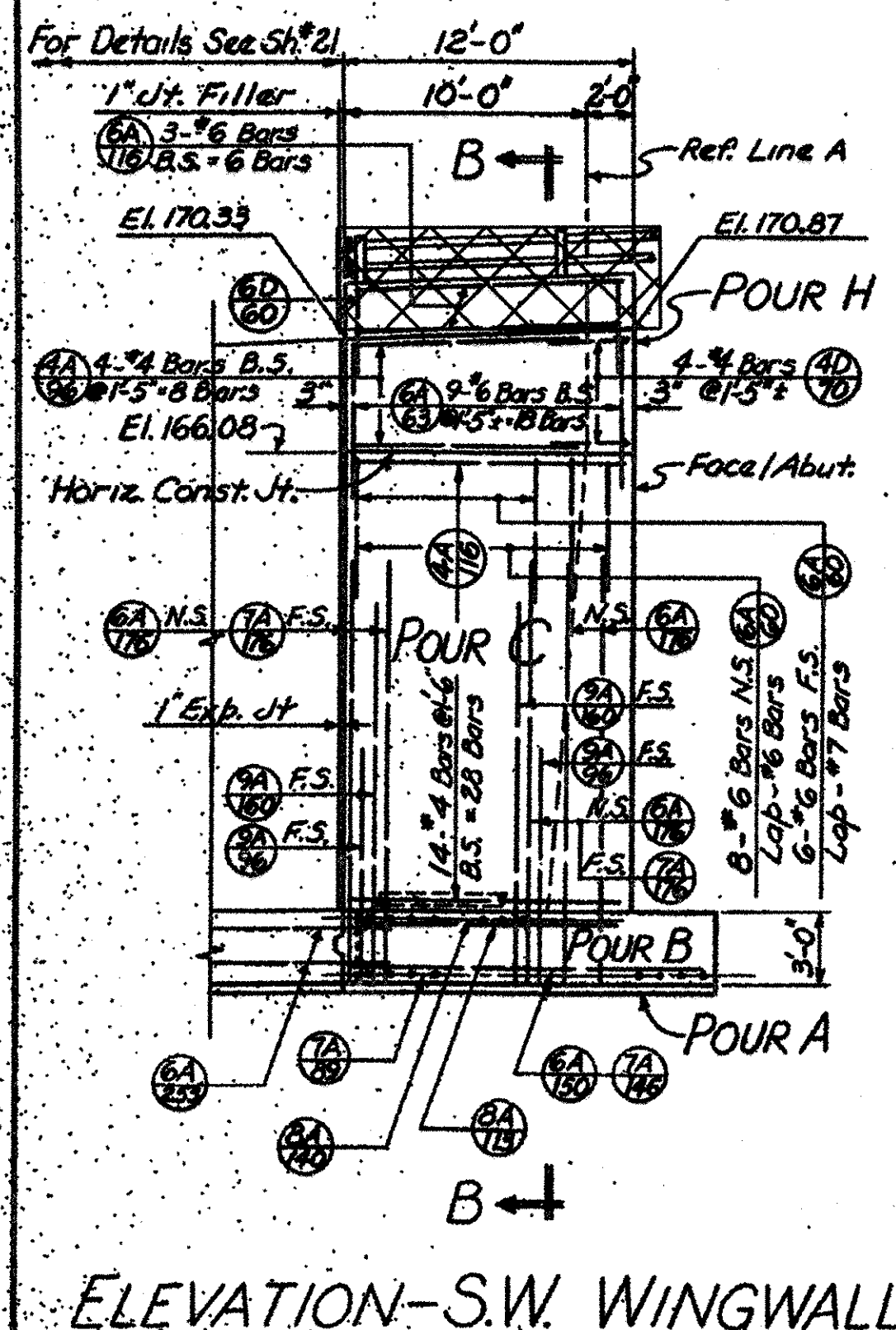

CONCRETE QUANTITIES		
Pour	Grade	Cu. Yds.
A	A	15.6
B	A(AA)	160.8
C	"	41.1
D	"	40.1
E	"	48.8
F	"	40.1
G	"	41.1
H	"	3.0
J	A(AA)	3.0

Total Grade A Concrete Subfooting = 15.6 C.Y.
Total G.A(AA) Concrete Substructure = 378.0 C.Y.

REMOVAL SHEET

JOB NUMBER 86173A

THE ONLY ITEMS OF WORK TO BE DONE FROM THIS SHEET ARE IDENTIFIED BY THE LEGEND BOX BELOW, LABELED WITH THIS PROJECT'S JOB NUMBER.

PROPOSED WORK
DENOTES REMOVAL PORTIONS

REVISIONS	DATE	BY	DESCRIPTION

BOARD OF WAYNE COUNTY ROAD COMMISSIONERS
DESIGN DIVISION

APPROVED: *Robert Cummings*
SOUND LEADER

Work this Sheet with Sh.# 10 & 29 T4000(3)

EAST GRAND BOULEVARD OVER GRAND TRUNK RAILROAD GRADE SEPARATION ABUTMENT A DETAILS (CONTD.)

COUNTY PROJECT 508
SHEET NO. 11
DATE 4-3-72

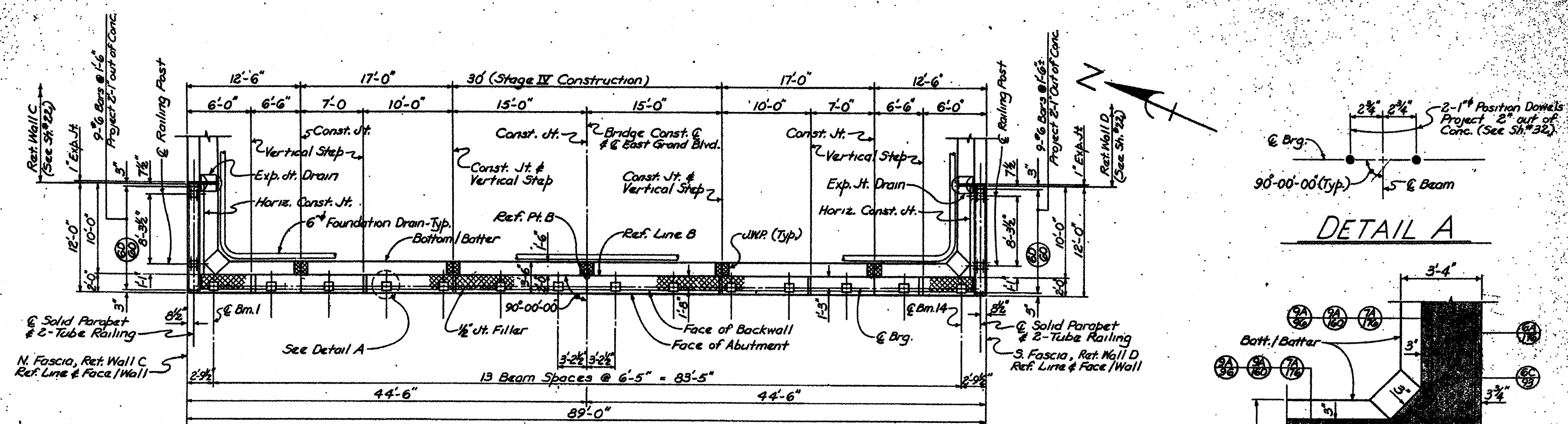

PLAN-ABOVE FOOTING

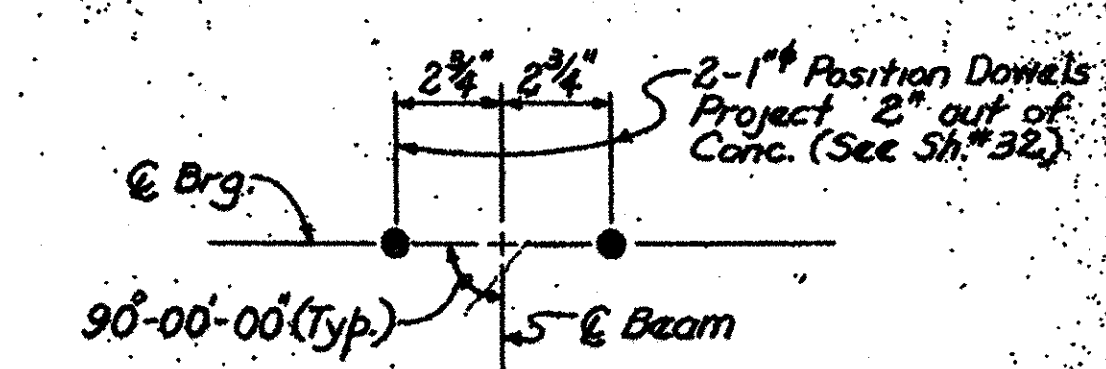

DETAIL A

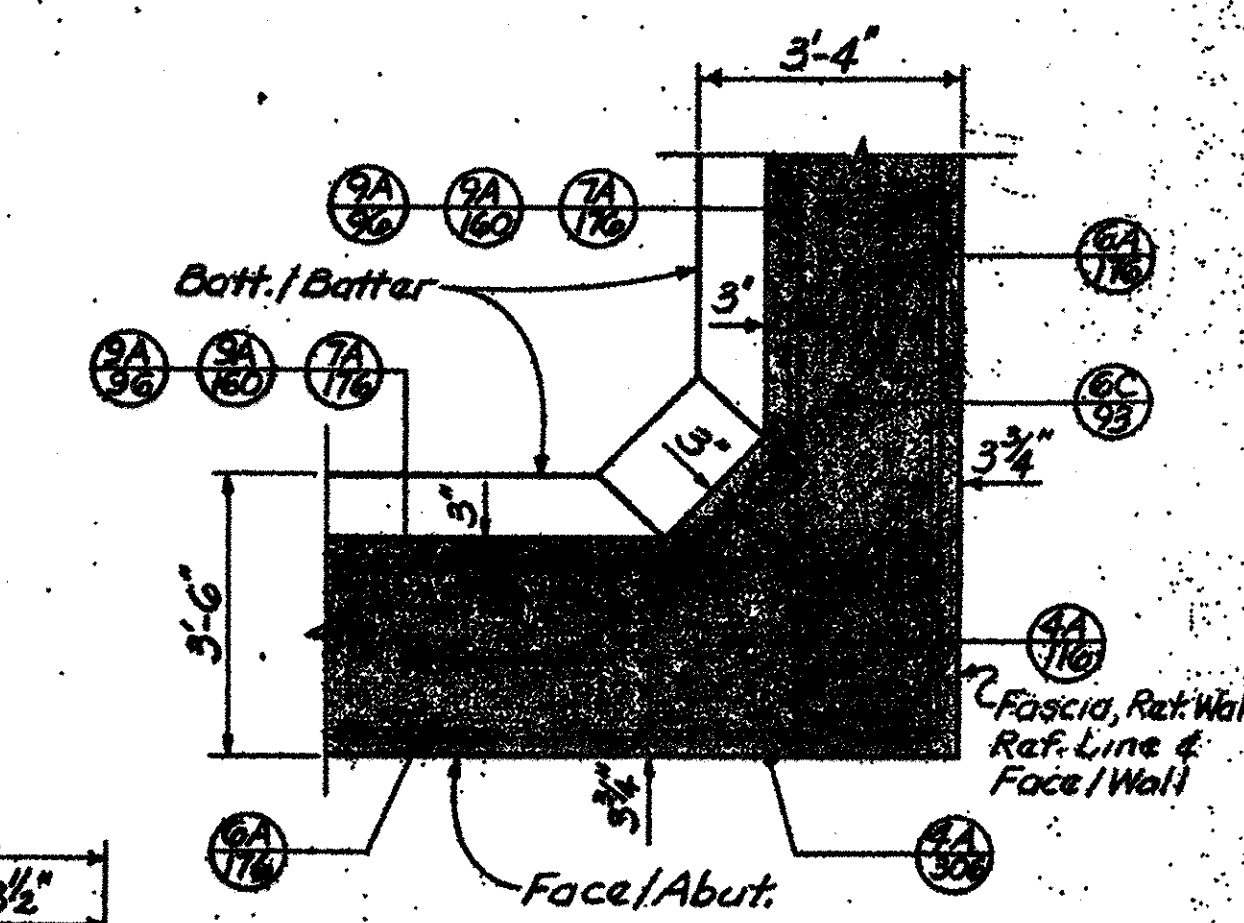

SECTION D-D

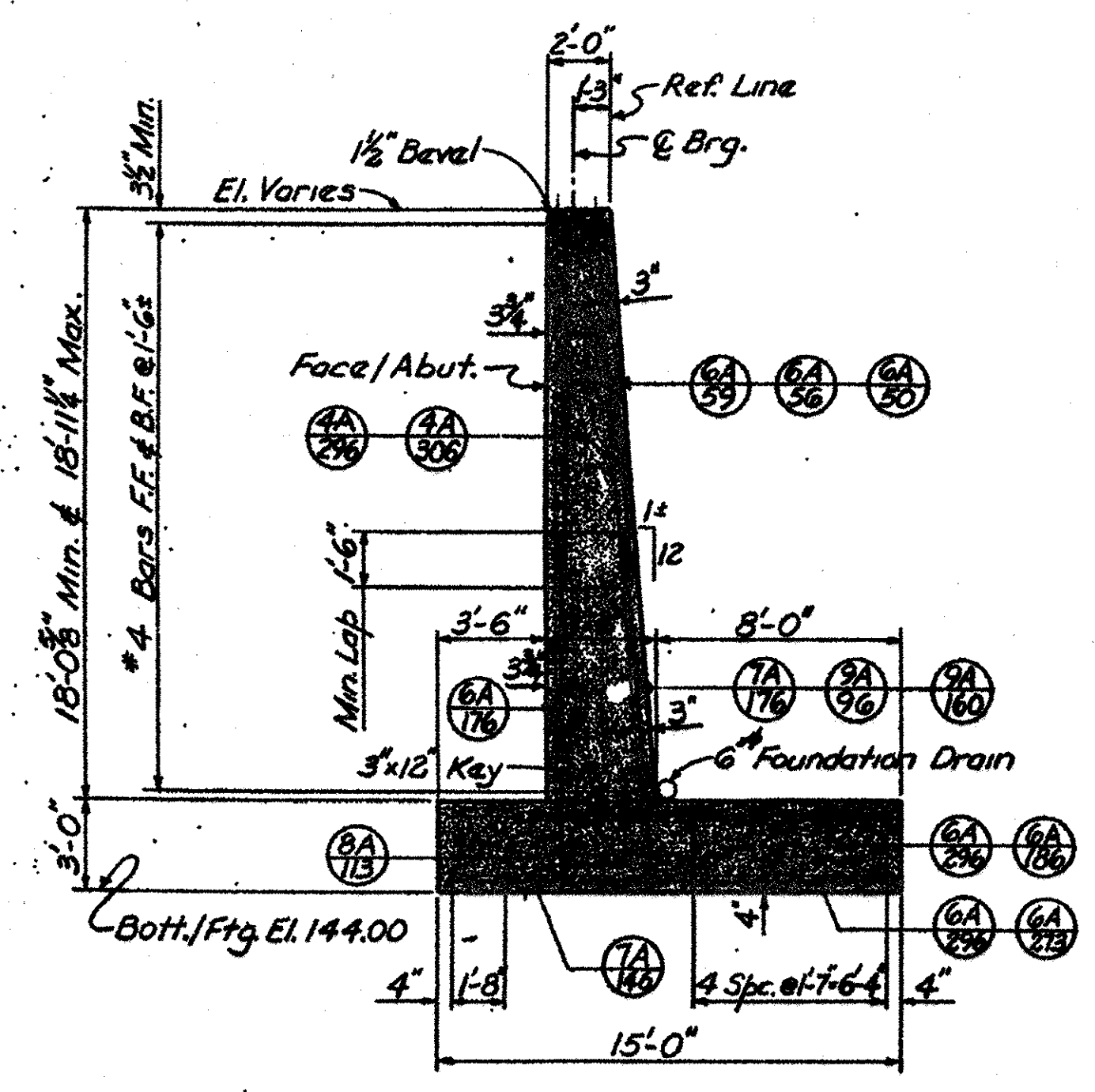

SECTION A-A

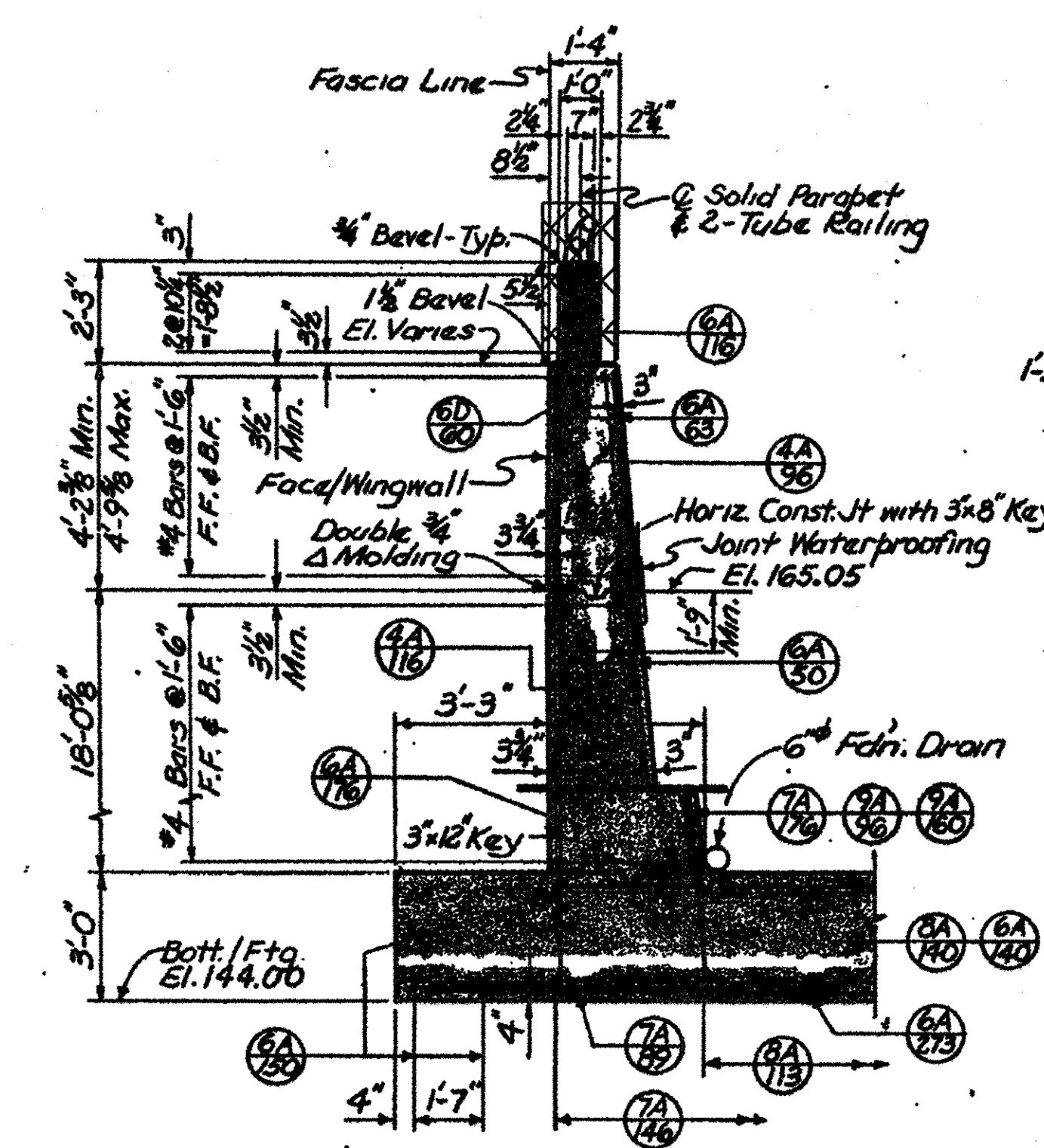

SECTION B-B

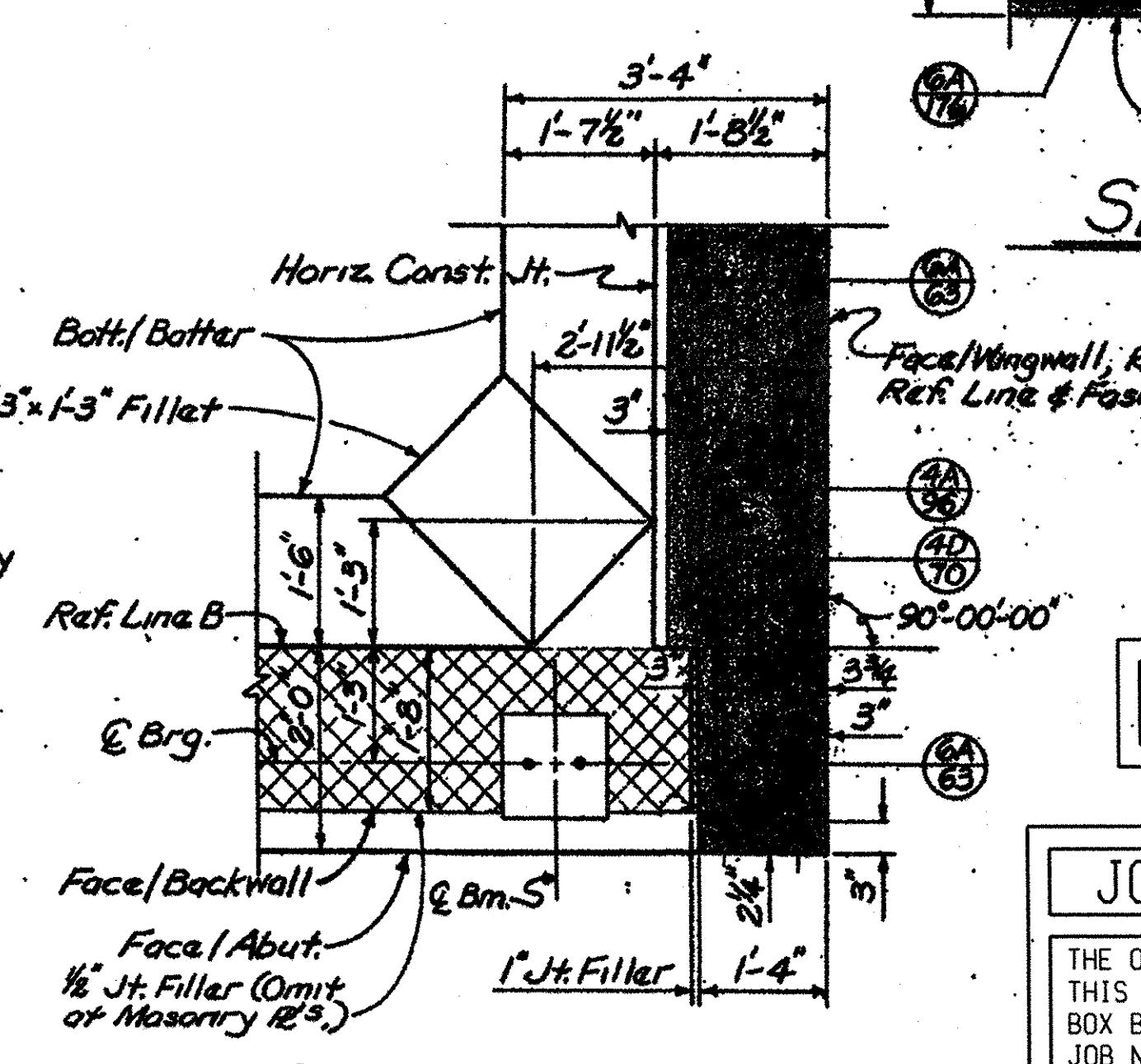

SECTION C-C

REMOVAL SHEET

JOB NUMBER 86173A

THE ONLY ITEMS OF WORK TO BE DONE FROM THIS SHEET ARE IDENTIFIED BY THE LEGEND BOX BELOW, LABELED WITH THIS PROJECT'S JOB NUMBER.

PROPOSED WORK
 DENOTES REMOVAL PORTIONS

Note:
South Corner shown in Section C-C & Section D-D. North Corner Similar, but Opposite Hand.

REVISIONS	DATE	BY

WAYNE COUNTY ROAD COMMISSIONERS
DESIGN DIVISION

EAST GRAND BOULEVARD OVER GRAND TRUNK RAILROAD GRADE SEPARATION ABUTMENT B DETAILS

DATE: 3-78

REVISIONS	DESCRIPTION	DATE	BY



EAST GRAND BLVD OVER DETROIT CONNECTING RAILROAD

MDOT JOB NO. 86173A STRUCTURE NO. R01 of 82-22-54

EX ABUTMENT B DETAILS (REMOVAL)

DATE: 04/16/08
DLZ JOB NO. 0642-6090-00
SHEET NO. 12 OF 60

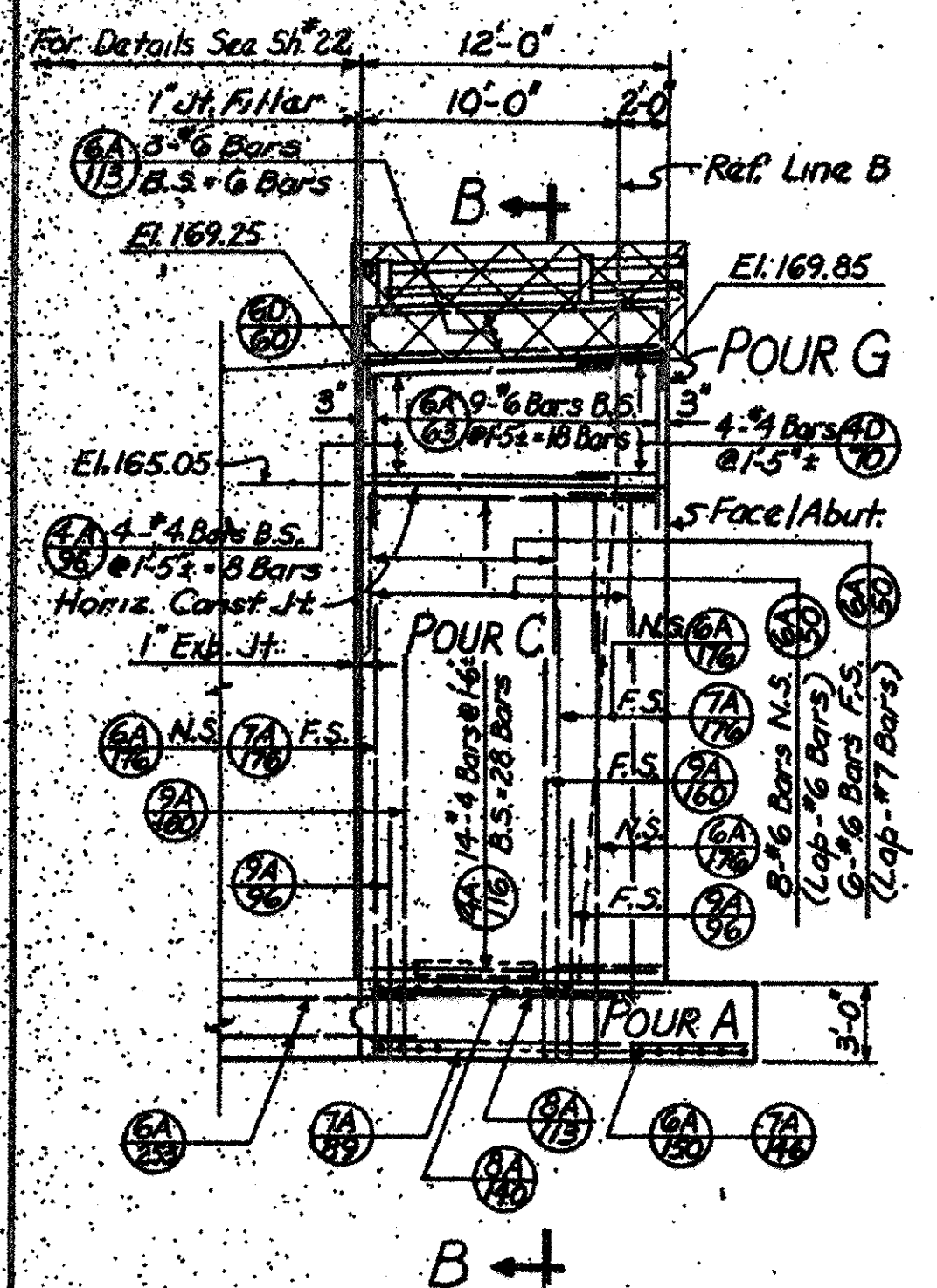

ELEVATION-N.W. WINGWALL

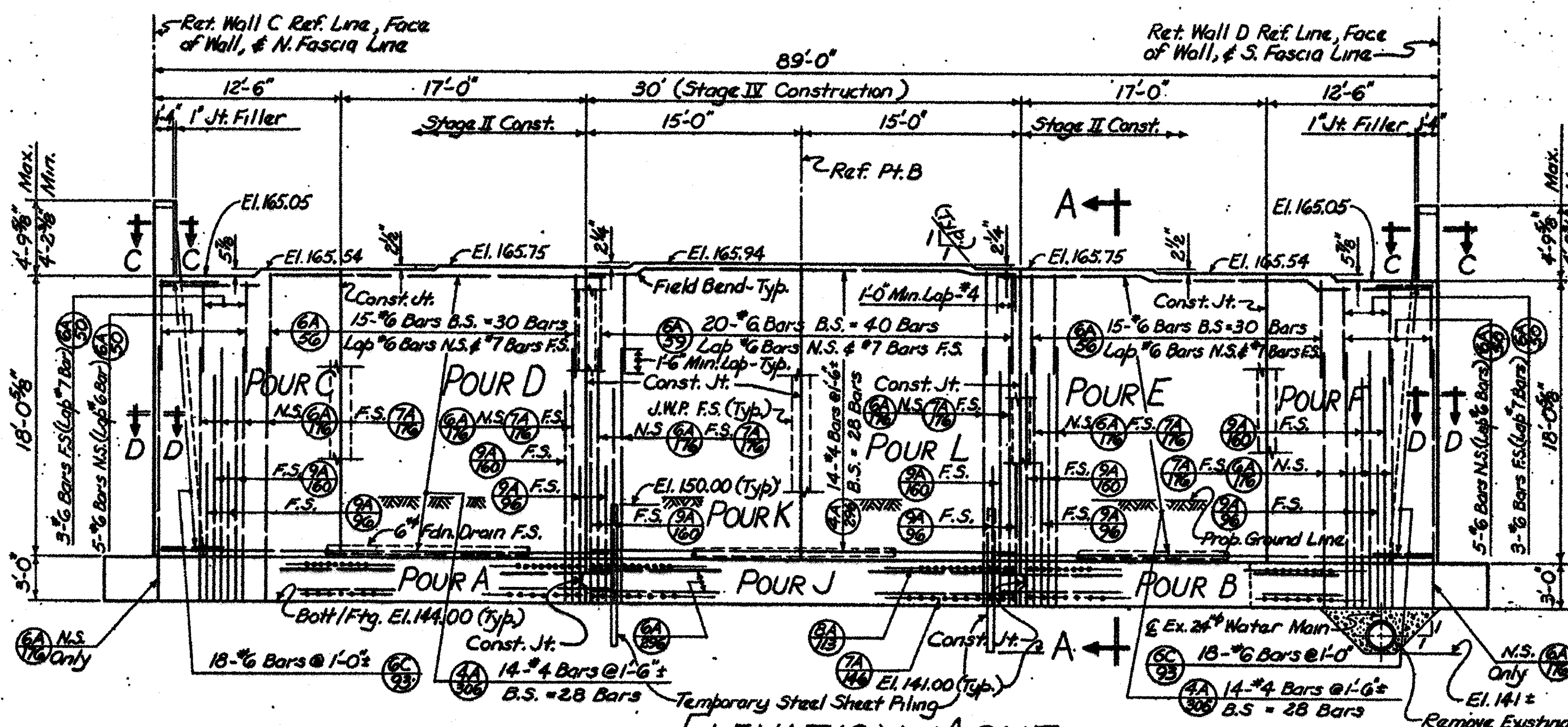

ELEVATION-ABUT.

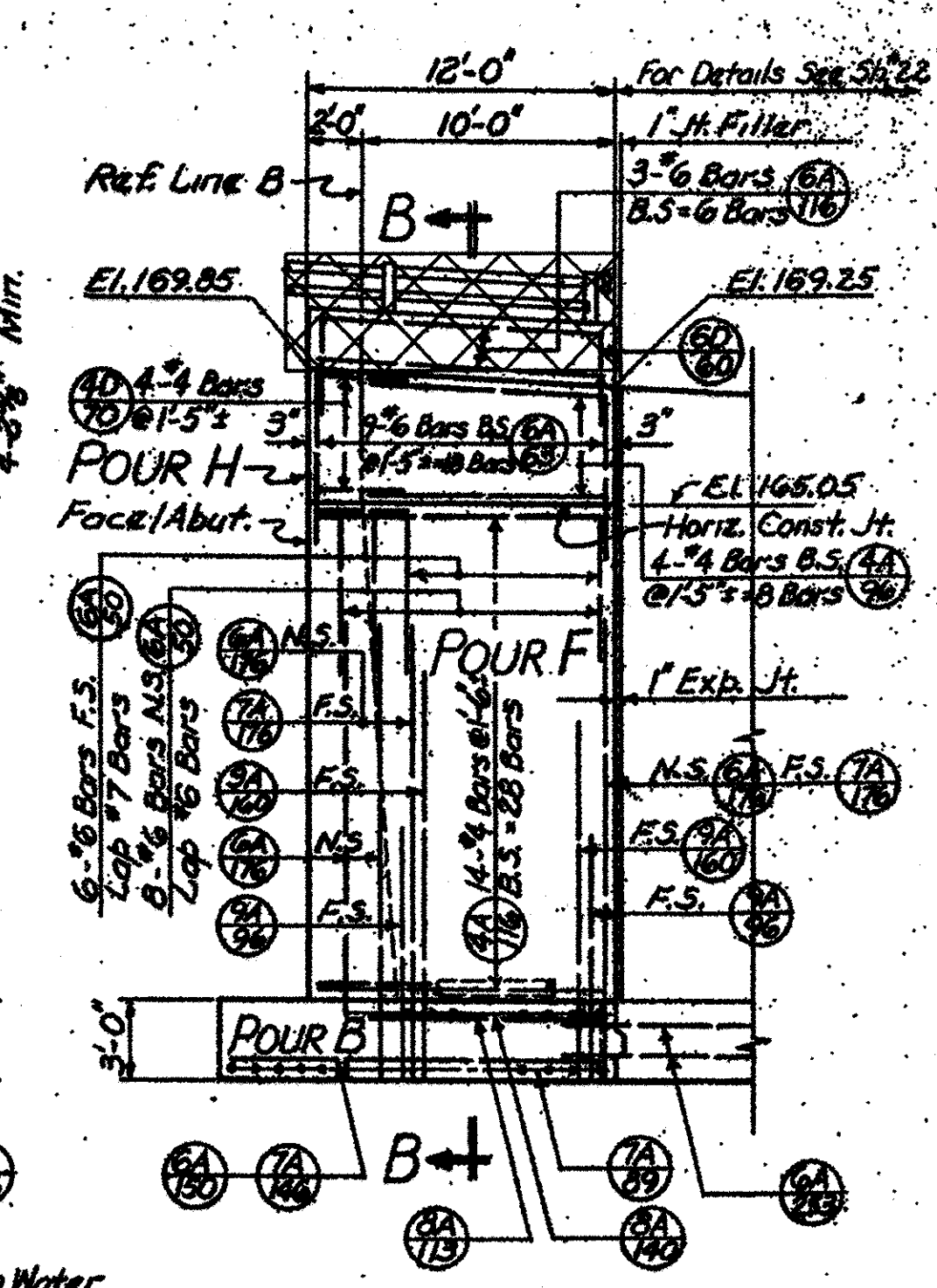

ELEVATION-SE. WINGWALL

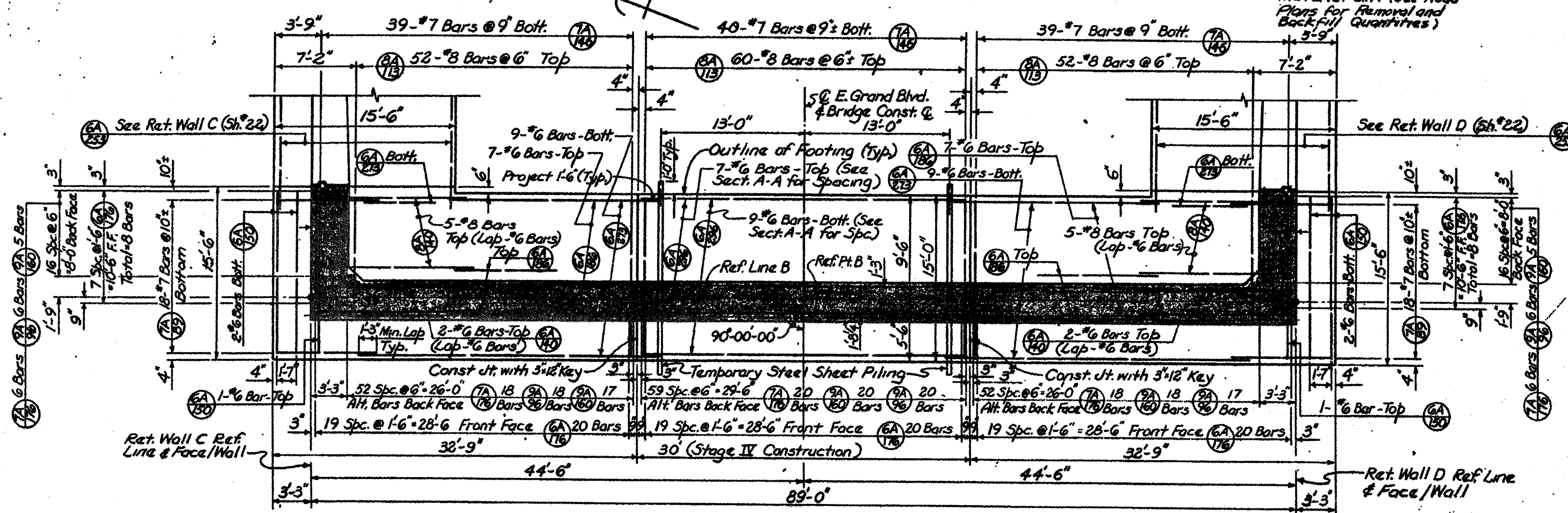

PLAN-FOOTING

CONCRETE QUANTITIES		
Pour	Grade	Cu. Yd.
A	A(GAA)	55.4
B	A(GAA)	55.4
C	A(GAA)	38.9
D	A(GAA)	32.3
E	A(GAA)	32.3
F	A(GAA)	39.4
G	A(GAA)	3.0
H	A(GAA)	3.0
J	A(GAA)	50.0
K	A(GAA)	28.9
L	A(GAA)	28.9
Total Gr. A(GAA) Concrete Substructure = 367.5 C.Y.		

REMOVAL SHEET

JOB NUMBER 86173A

THE ONLY ITEMS OF WORK TO BE DONE FROM THIS SHEET ARE IDENTIFIED BY THE LEGEND BOX BELOW, LABELED WITH THIS PROJECT'S JOB NUMBER.

PROPOSED WORK
 DENOTES REMOVAL PORTIONS

REVISIONS	DATE	BY	DESCRIPTION

WAYNE COUNTY ROAD COMMISSIONERS
 DESIGN DIVISION

EAST GRAND BOULEVARD OVER GRAND TRUNK RAILROAD GRADE SEPARATION ABUTMENT B DETAILS (CONTD.)

REVISIONS	DESCRIPTION	DATE	BY



EAST GRAND BLVD OVER DETROIT CONNECTING RAILROAD
 MDOT JOB NO. 86173A STRUCTURE NO. R01 of 82-22-54

EX ABUTMENT B DETAILS (REMOVAL)

DATE: 04/16/08
 DLZ JOB NO. 0642-6090-00
 SHEET NO. 13 OF 60

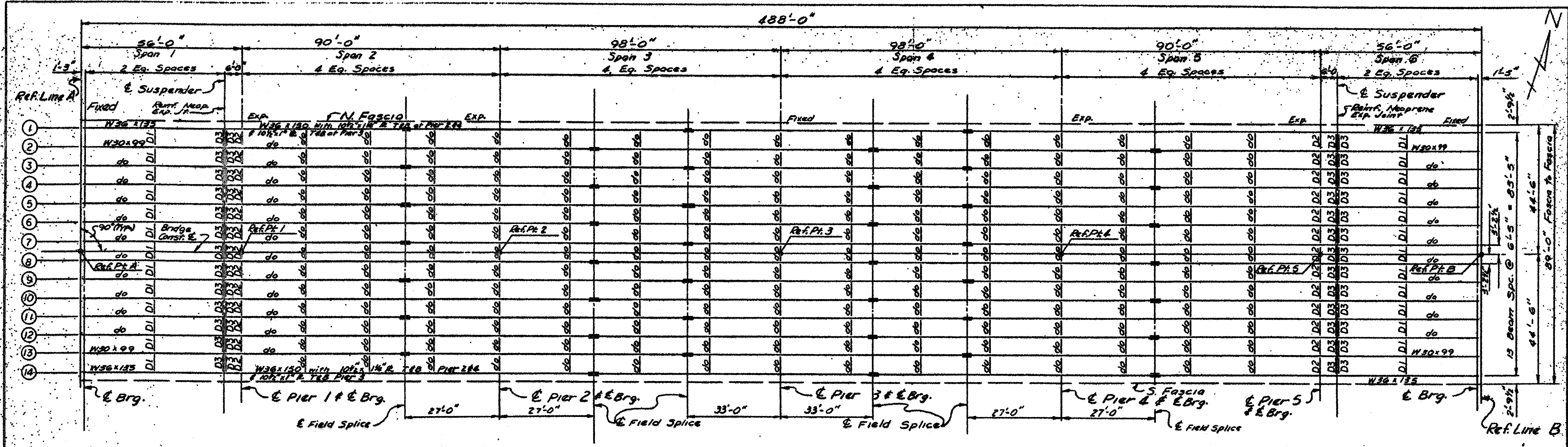

ERECTOR DIAGRAM

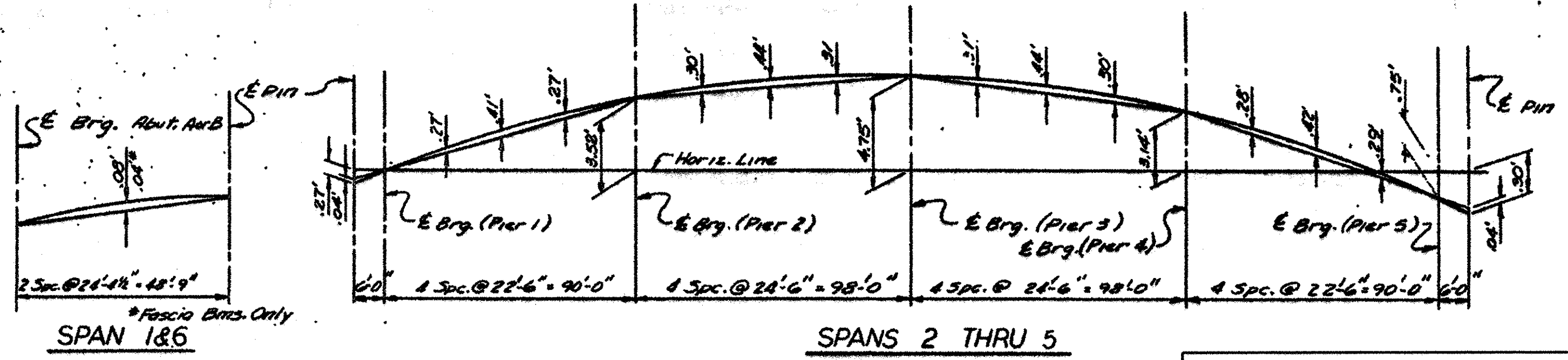

CAMBER DIAGRAM

Deflections due to Steel Wt Only
 A Spans 1 & 6 = .01'
 A Spans 2 & 5 = .05'
 A Spans 3 & 4 = .01'

EXISTING
 FOR INFORMATION ONLY
 DO NOT WORK FROM THIS SHEET.
 THE INFORMATION SHOWN HERE IS FOR REFERENCE ONLY. NO PAY ITEMS ARE SHOWN.

QUANTITIES		
ITEM	UNIT	AMOUNT
Structural Steel - Furnishing & Fabricating	Lbs.	1,240,200
Structural Steel - Erection	Lbs.	1,240,200
Steel Developers	Lump Sum	

NOTE:
 The quantity Structural Steel Furnishing and Fabricating includes:
 A308 Steel = 1,239,213 lbs.
 Bronze = 68 lbs.
 Lead = 919 lbs.
 Total = 1,240,200 lbs.

NOTES

FABRICATION: Michigan Department of State Highways Standard Specifications for Highway Construction - 10 Edition.

DESIGN: M.D.S.H. Specifications for Design of Highway Bridges - 1950 Edition and A.S.H.S. Standard Specifications for Highway Bridges, current edition (MS20-44 Loading).

CONNECTIONS: All Shop connections shall be welded as shown on the plans.
 Field Connections, splices shall be bolted with 7/8" # high-strength bolts other connections shall be 3/4" # high-strength bolts.

MATERIAL: All structural steel shall be A.S.T.M. A-588, Anchor bolts maybe A.S.T.M. A307

GALVANIZING: All steel material used for bearings, with exception of portion welded to beams, shall be galvanized in accordance with ASTM Designation A123. Galvanizing shall be applied after fabrication of bearing. Mill scale and foreign material shall be removed prior to galvanizing.

SOLE PLATES: Sole plates 3" or more in thickness may be built up by welding together plates not less than 1-1/2" in thickness. Edges must be beveled 1/4" and welded with a continuous weld for the full perimeter. Voids shall be ground flush with faces of plates.

CAMBER: The beams in all spans are to have a camber as shown. This camber is to be measured with the beam lying on its side. Allowable camber tolerance for rolled beams is ± 1/4". Noting is to be used, if necessary, to assure camber permanency within the above limitations. Dead load deflections of the beams alone are as shown.

MAGNETIC PARTICLE INSPECTION: Magnetic Particle inspection of welds is required and shall consist of 100% inspection of not less than one fabricated section selected at random for each ten sections or fractions thereof.

ANCHOR BOLTS: Anchor Bolts and Position Dowels shall be galvanized in accordance with ASTM Designation A153. Anchor Bolts and Position Dowels are included in the Structural Steel Weights.

BRONZE: Bronze for washers shall be ASTM B100, Alloy No. 510 or No. 635.

PINS: Steel for pins shall be ASTM A588, ASTM A235 Class G or ASTM A108 having a minimum yield point of 50,000 psi.

REVISIONS NO. 31-72 DATE 5-1-72	DRAWN BY S. WOODRIDGE	CHECKED BY H. HADKINSON	DATE 1-18-72	CORRECT APPROVED ESTER COMPTON BOARD LEADER	BOARD OF WAYNE COUNTY ROAD COMMISSIONERS DESIGN DIVISION	EAST GRAND BOULEVARD OVER GRAND TRUNK RAILROAD GRADE SEPARATION STRUCTURAL STEEL DETAILS	COUNTY PROJECT 508	COUNTY JOB 14000(3)	SHEET NO. 30
---------------------------------------	--------------------------	----------------------------	-----------------	--	--	---	-----------------------	------------------------	-----------------

FILE

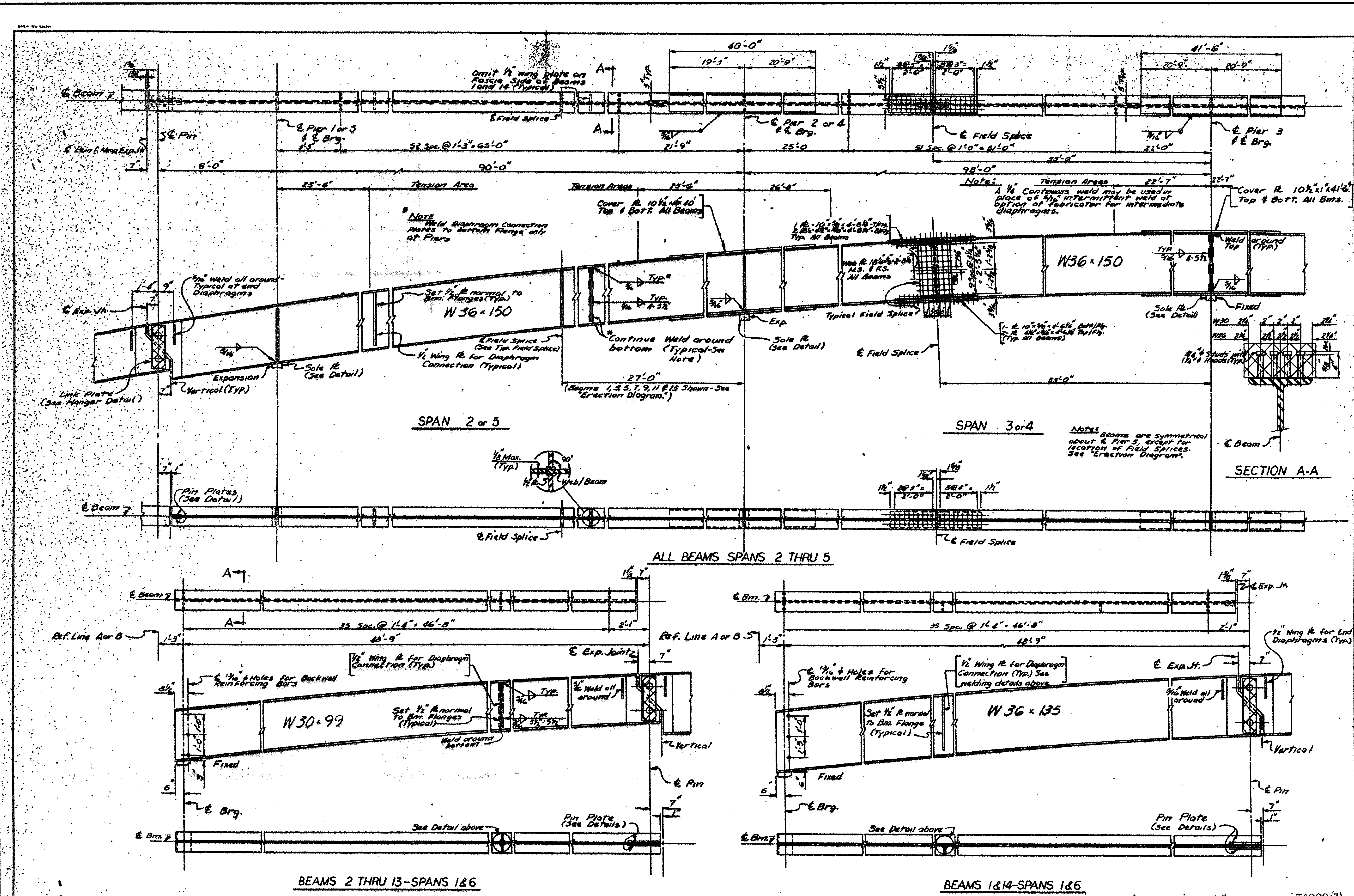

REMOVAL SHEET

JOB NUMBER 86173A

THE ONLY ITEMS OF WORK TO BE DONE FROM THIS SHEET ARE IDENTIFIED BY THE LEGEND BOX BELOW, LABELED WITH THIS PROJECT'S JOB NUMBER.

PROPOSED WORK

 DENOTES REMOVAL PORTIONS

REVISIONS	DATE	BY	DESCRIPTION
MOSH Revisions 5-1-78			

BOARD OF
WAYNE COUNTY ROAD COMMISSIONERS
 DESIGN DIVISION

Work this sheet with S.H.S. # 30 & 32 T4000(3)
 EAST GRAND BOULEVARD OVER
 GRAND TRUNK RAILROAD
 GRADE SEPARATION
 STRUCTURAL STEEL DETAILS (CONT'D)
 COUNTY PROJECT 508
 SHEET NO. 31
 DATE 5-1-78

REVISIONS	DESCRIPTION	DATE	BY



EAST GRAND BLVD OVER
 DETROIT CONNECTING RAILROAD
 MDOT JOB NO. 86173A STRUCTURE NO. R01 of 82-22-54

EX STRUCTURAL STEEL DETAILS
 (REMOVAL)

DATE: 04/16/08
 DLZ JOB NO. 0642-6090-00
 SHEET NO. 15 OF 60

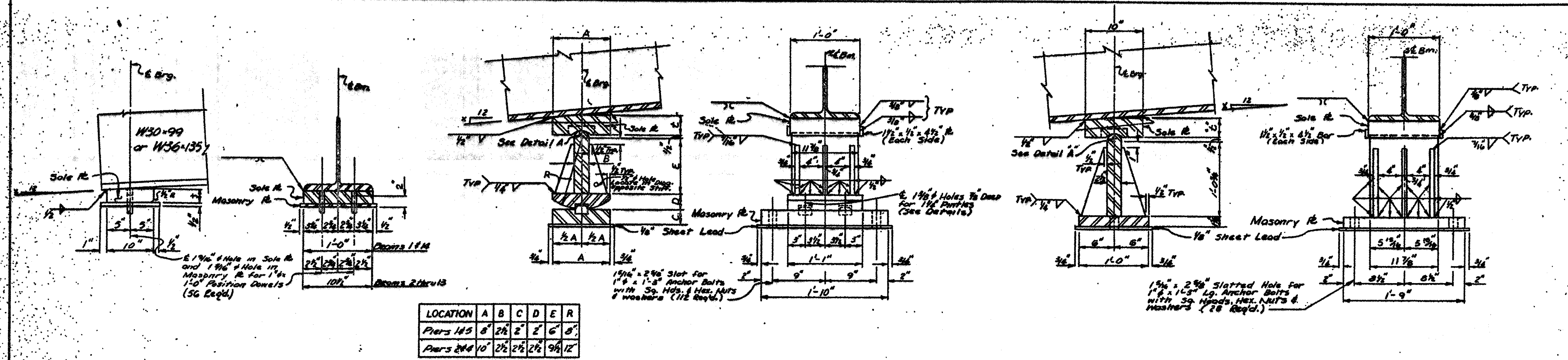

LOCATION	A	B	C	D	E	R
Piers 1&5	8'	2 1/2'	2'	2'	6'	8'
Piers 2&4	10'	2 1/2'	2 1/2'	2 1/2'	9 1/2'	12'

FIXED BEARING DETAILS-ABUTMENTS

EXPANSION BEARING DETAILS-PIERS 1,2,4&5

FIXED BEARING DETAILS-PIER 3

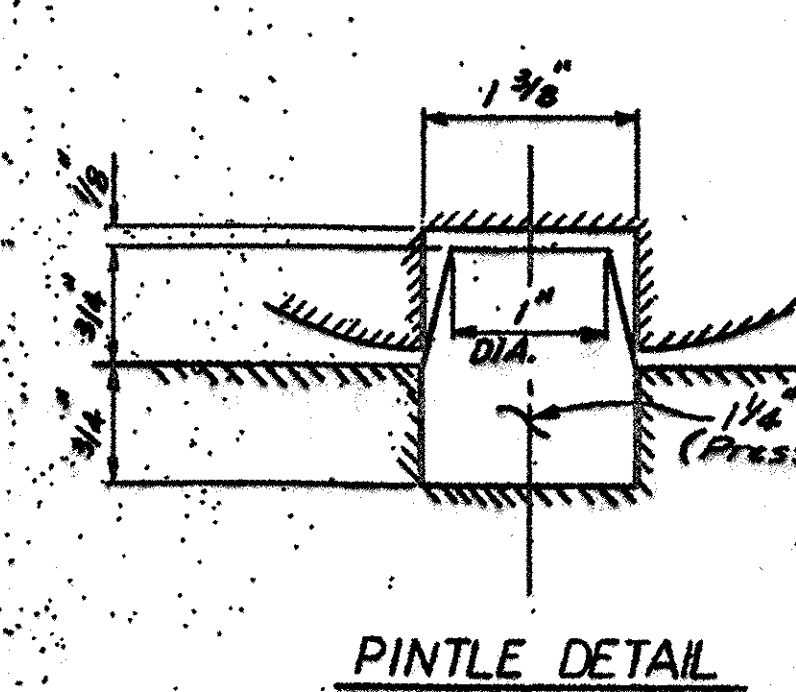

PINTLE DETAIL

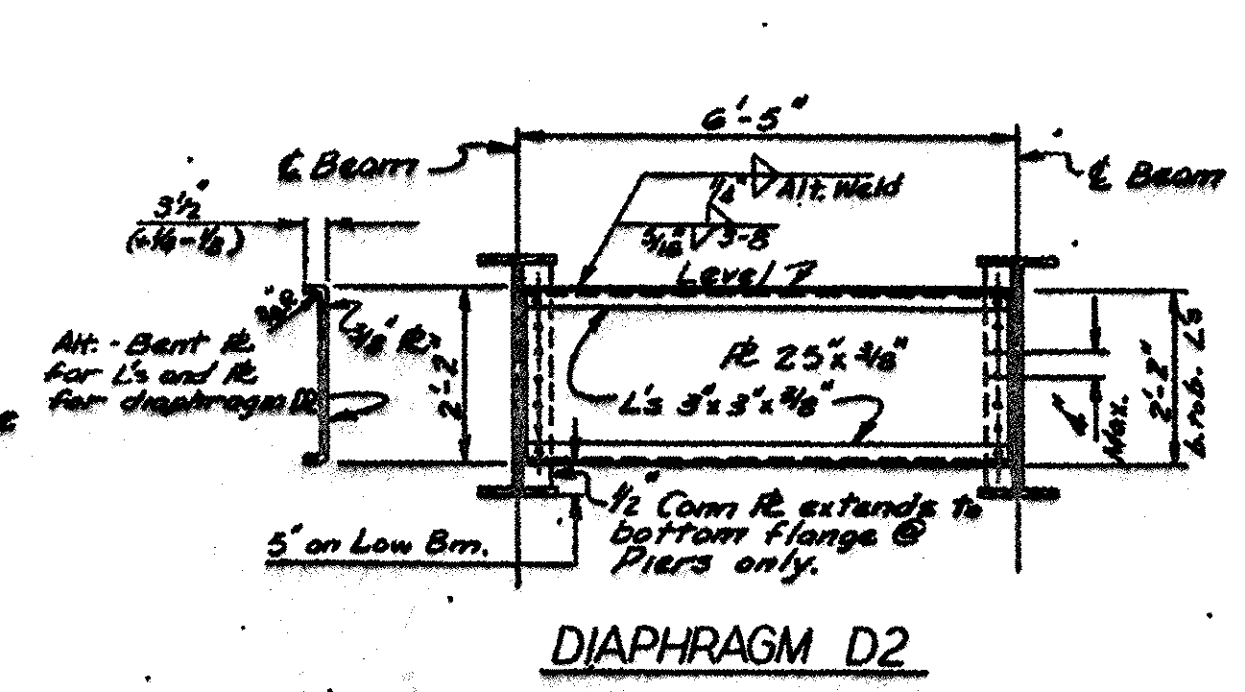

DIAPHRAGM D2

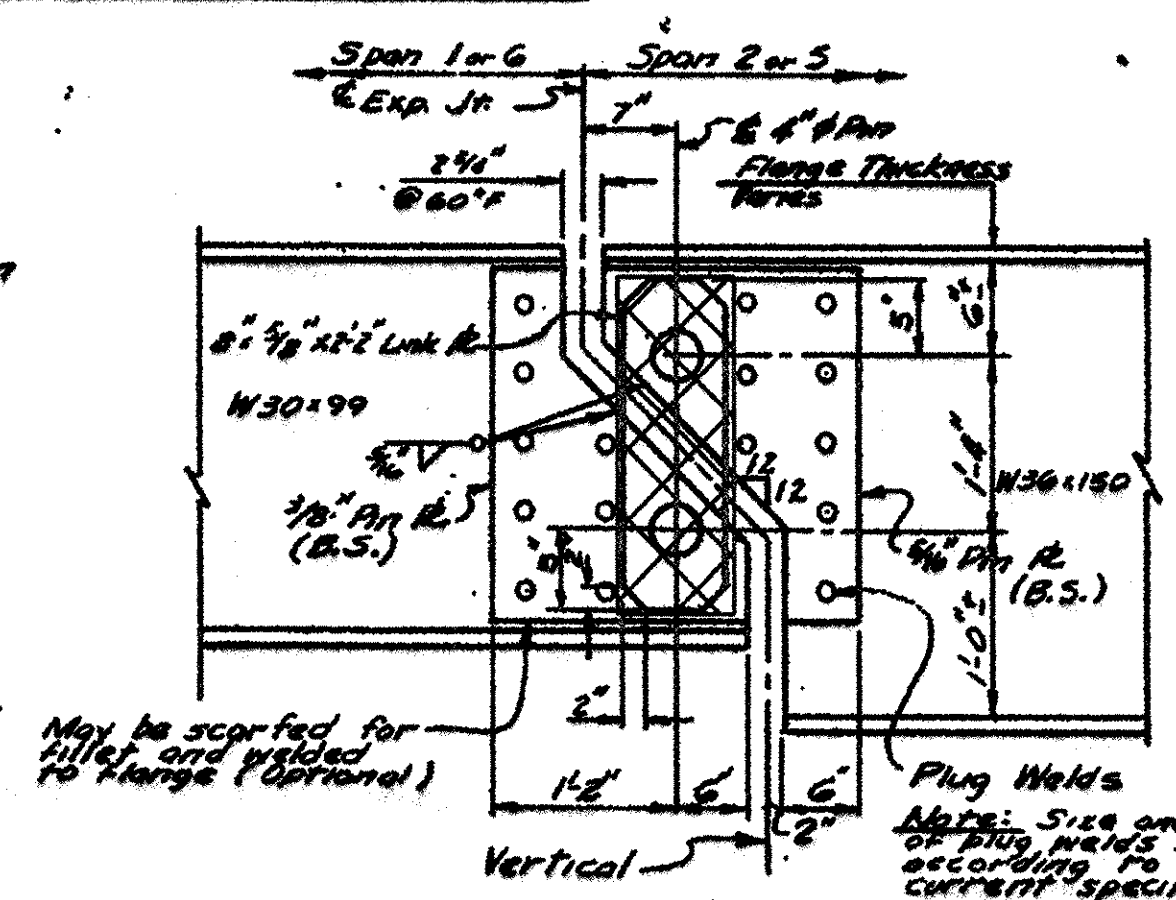

HANGER DETAILS

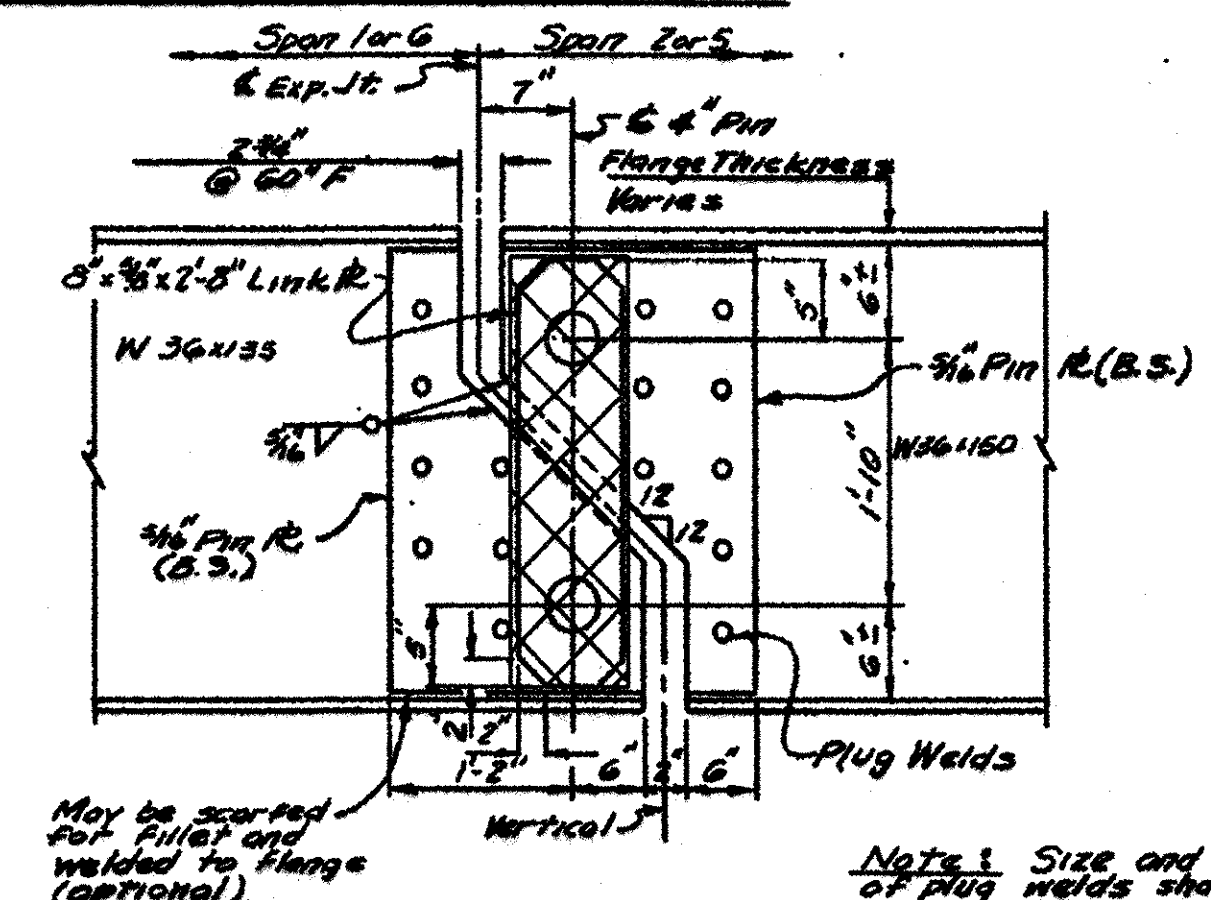

HANGER DETAILS

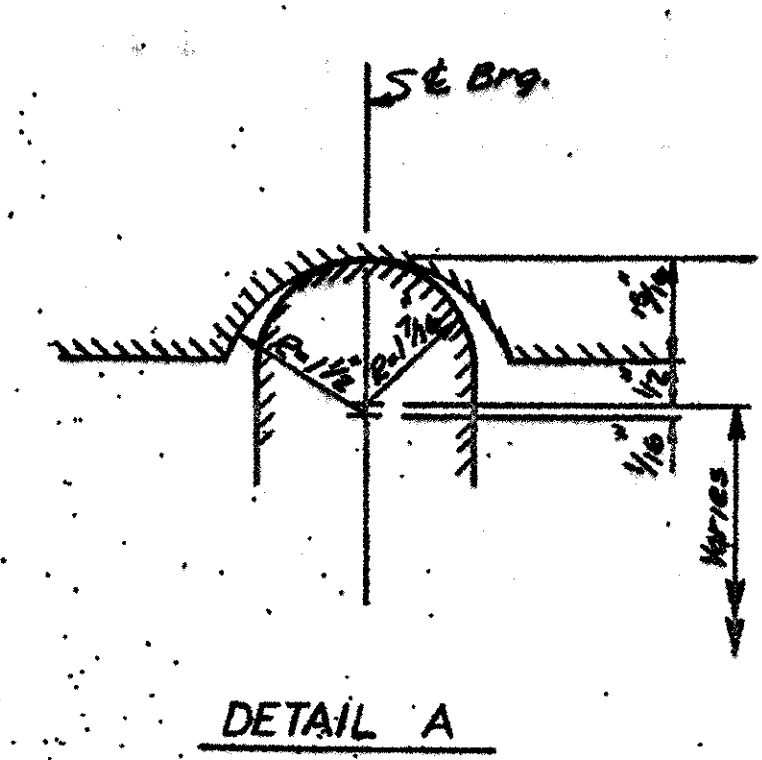

DETAIL A

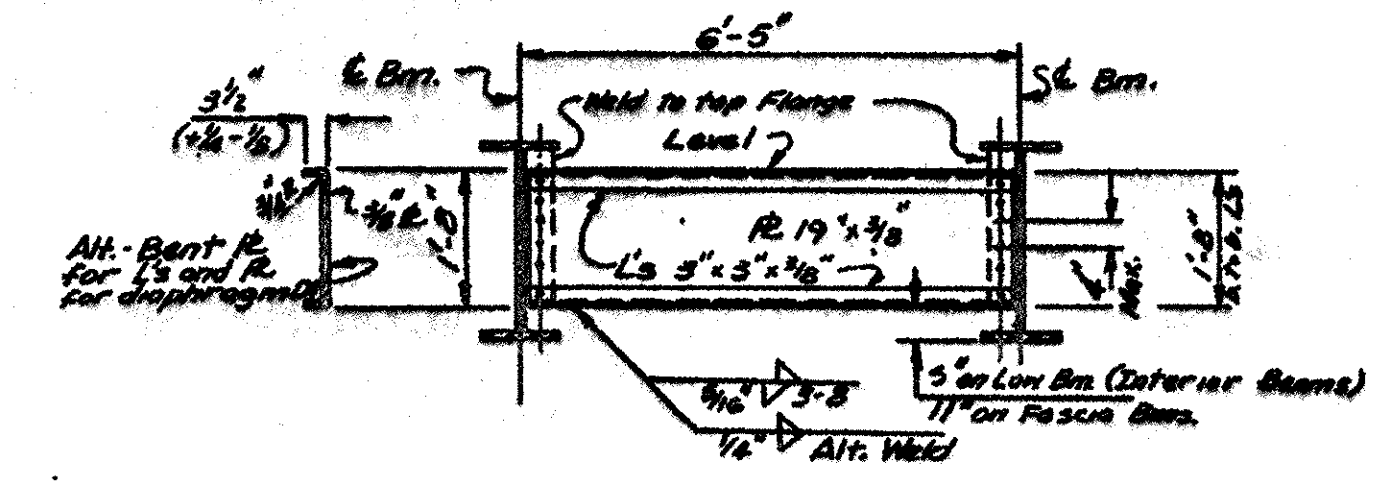

DIAPHRAGM D1

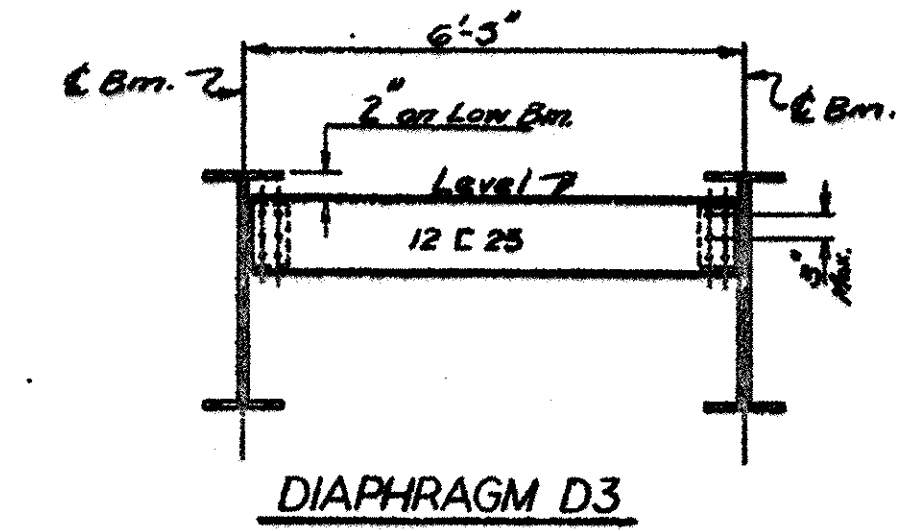

DIAPHRAGM D3

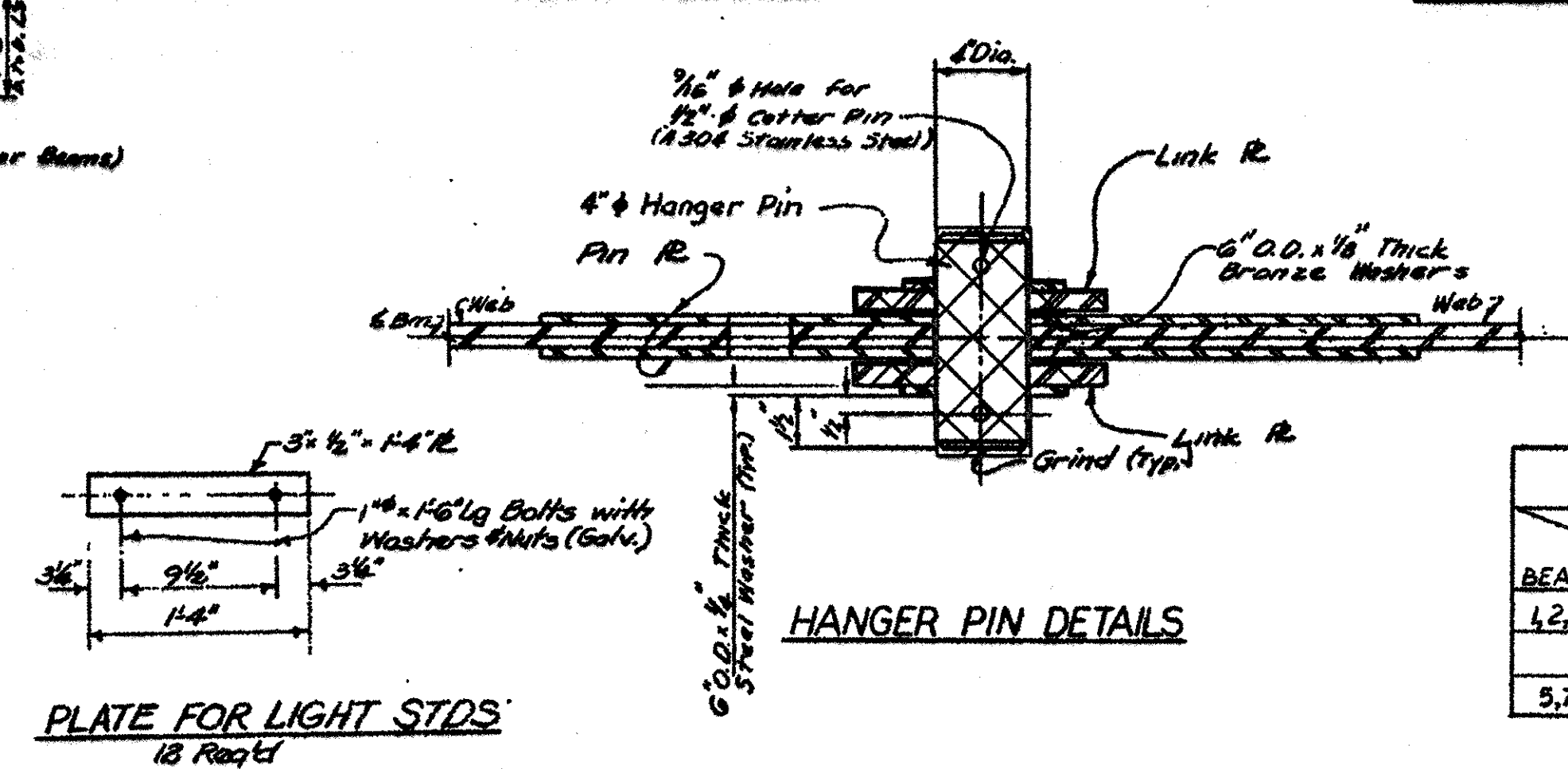

HANGER PIN DETAILS

PLATE FOR LIGHT STDS
1/8" Thick

LOCATION	BEAMS	'X' FOR ALL BEAMS
ABUT. A & PIER 1		+ 9/16"
PIER 2		+ 9/16"
PIER 3		0"
PIER 4		- 3/8"
PIER 5 & ABUT. B		- 5/16"

LOCATION	ABUT. A OR B	PIERS 1 OR 5	PIERS 2, 3 OR 4
BEAMS	1"	1"	1"
1, 2, 4, 5, 9, 11, 13 & 14	2"	2 1/2"	3"
3 AND 12	3 1/2"	3 1/2"	4 1/2"
5, 7, 8 AND 10	3"	3 1/2"	4"

REMOVAL SHEET

JOB NUMBER 86173A

THE ONLY ITEMS OF WORK TO BE DONE FROM THIS SHEET ARE IDENTIFIED BY THE LEGEND BOX BELOW, LABELED WITH THIS PROJECT'S JOB NUMBER.

PROPOSED WORK
DENOTES REMOVAL PORTIONS

REVISIONS	REVISIONS	DATE	BY

BOARD OF
WAYNE COUNTY ROAD COMMISSIONERS
DESIGN DIVISION

Work this sheet with sheets #30 & #31 T4000(3)

EAST GRAND BOULEVARD OVER
GRAND TRUNK RAILROAD
GRADE SEPARATION
STRUCTURAL STEEL DETAILS (CONT'D)

COUNTY PROJECT: 508
SHEET NO: 32
DATE: 4-3-72

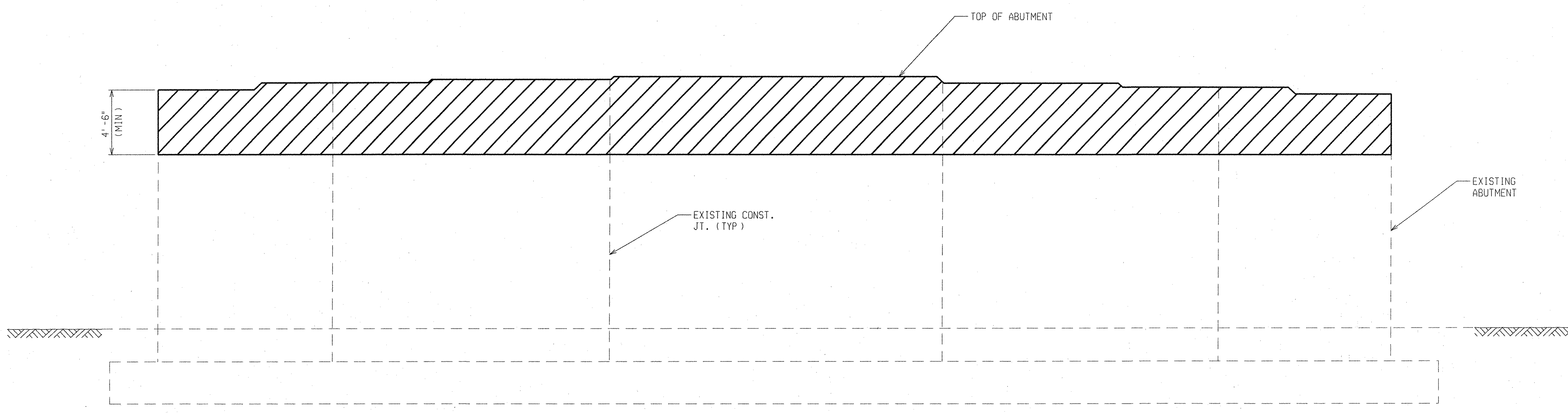

TYPICAL ABUTMENT ELEVATION
SCALE: NONE

MISCELLANEOUS QUANTITIES		
ABUTMENTS	PIERS	
450	50	Cft Hand Chipping, Other Than Deck
890	100	Sft Patch, Forming
17	2	Cyd Patching Conc, C-L
340	15	Syd Water Repellent Treatment, Penetrating
	200	Ft Structural Crack, Repr
	200	Ft Flushing Cracks, Water

NOTES:

FORMS FOR LARGE PATCHES SHALL BE INSTALLED IN 2'-0" TO 4'-0" HIGH SECTIONS WITH THE TOP OF THE FORM NO MORE THAN 4'-0" ABOVE THE LEVEL OF CONCRETE AS THE POUR PROGRESSES.

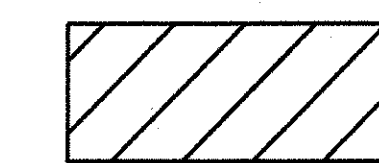

DENOTES AREAS OF THE ABUTMENTS TO BE REPAIRED.

QUANTITIES FOR THE PIERS ARE UNDISTRIBUTED QUANTITIES AND THE REPAIRS TO THE PIERS SHALL BE AS DIRECTED BY THE ENGINEER.

REVISIONS	DESCRIPTION	DATE	BY



EAST GRAND BLVD OVER
DETROIT CONNECTING RAILROAD
MDOT JOB NO. 86173A STRUCTURE NO. R01 of 82-22-54

SUBSTRUCTURE REPAIR DETAILS

DATE: 04/16/08
DLZ JOB NO. 0642-6090-00
SHEET NO. 17 OF 60

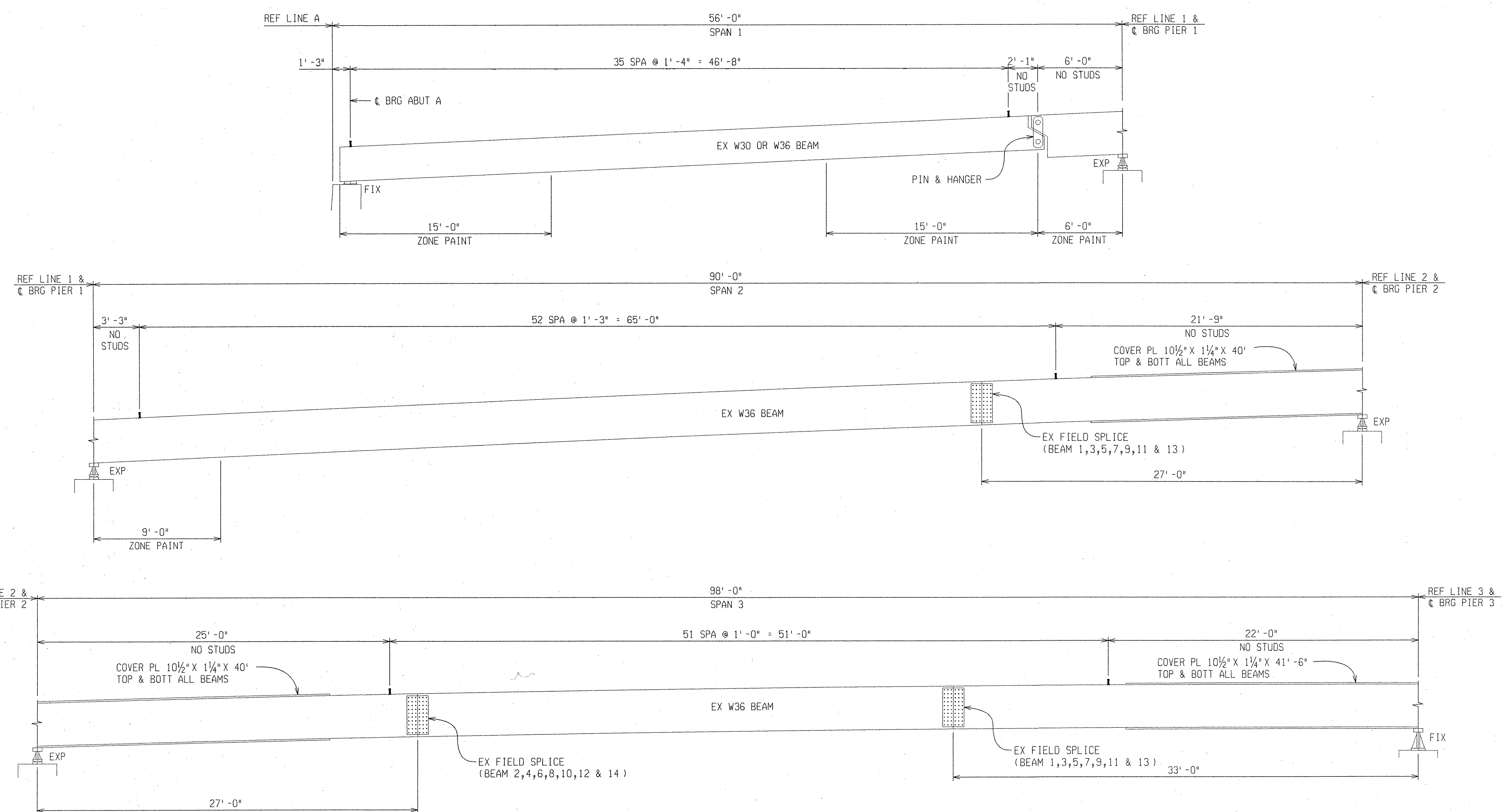

SHEAR DEVELOPER SPACING

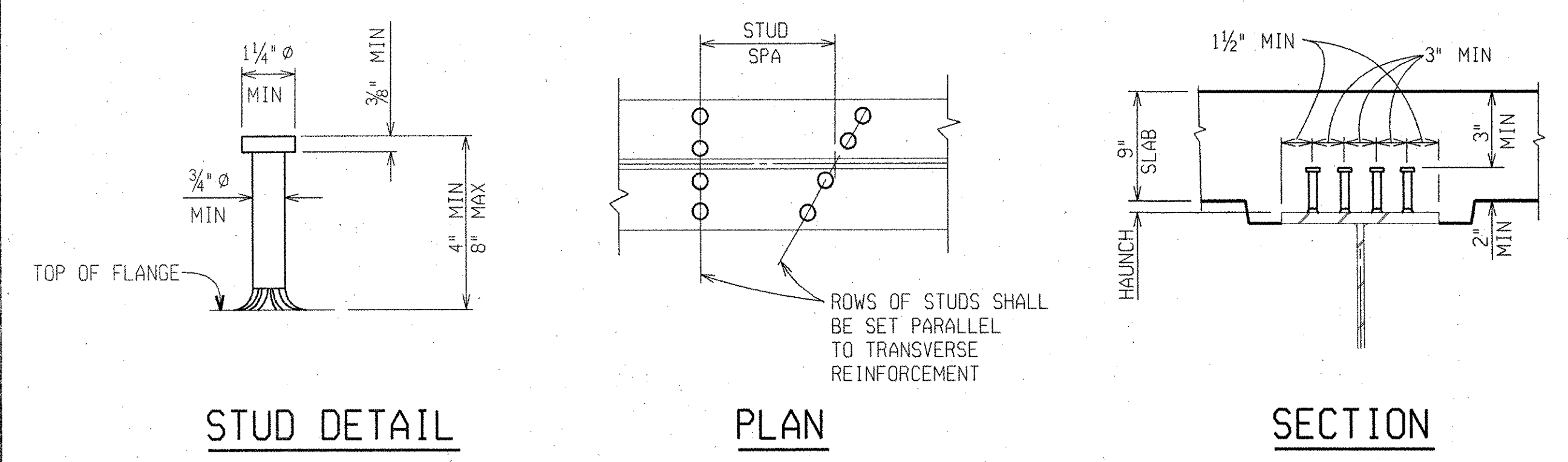

STUD SHEAR DEVELOPER DETAILS

NOTES:

- SHEAR DEVELOPERS SHALL BE 3/8" DIAMETER STUDS.
- IF EXISTING SHEAR DEVELOPERS DO NOT INTERFERE WITH PROPOSED SHEAR DEVELOPERS AND REINFORCEMENT, THEY MAY BE CLEANED AND LEFT IN PLACE INSTEAD OF REMOVED. THE CONTRACTOR SHALL INSTALL ALL PROPOSED SHEAR DEVELOPERS REGARDLESS OF WHETHER OR NOT THE EXISTING SHEAR DEVELOPERS REMAIN.
- THIS BRIDGE HAS UNCOATED A588 STRUCTURAL STEEL. THE ADDITIONAL EFFORT TO CLEAN THE STRUCTURAL STEEL WILL NOT BE PAID FOR SEPARATELY, BUT WILL BE CONSIDERED INCLUDED IN THE BID ITEMS.
- SEE SUBSECTION 715 OF THE STANDARD SPECIFICATIONS FOR PROTECTION OF WORK AND ENVIRONMENT DURING THE BLAST CLEANING OF THIS STRUCTURE.
- AFTER THE REMOVAL OF THE EXISTING CONCRETE BACKWALL, WHEN THE BEARINGS AT THE ABUTMENTS ARE EXPOSED, THE CONTRACTOR SHALL PROVIDE THE ENGINEER WITH THE OPPORTUNITY TO INSPECT THE BEARINGS FOR EXCESSIVE DETERIORATION.
- THE SOLE PLATES AND MASONRY PLATES OF THE BEARINGS AT THE ABUTMENTS SHALL BE CLEANED AND COATED AFTER THE REMOVAL OF THE EXISTING CONCRETE BACKWALL AND PRIOR TO POURING THE PROPOSED BACKWALL. (INCLUDED IN THE BID ITEM "Steel Structure, Coating, Partial Type 4 (R01 of 82-22-54)")
- THE ESTIMATED AREA OF STRUCTURAL STEEL TO BE COATED IS 3,855 SQUARE FEET.
- THE CONTRACTOR SHALL TAKE NECESSARY MEASURES TO AVOID OVSERSPRAY ON ADJACENT SUBSTRUCTURE AND SUPERSTRUCTURE CONCRETE SURFACES. (INCLUDED IN THE BID ITEM "Steel Structure, Coating, Partial Type 4 (R01 of 82-22-54)")

REVISIONS	DESCRIPTION	DATE	BY

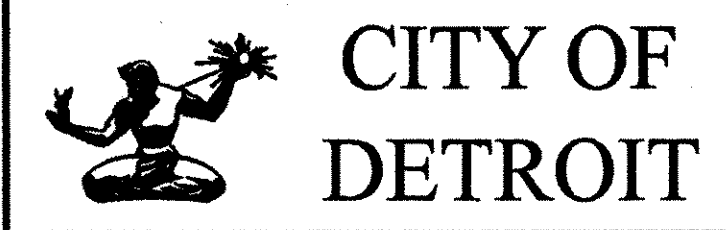

EAST GRAND BLVD OVER
DETROIT CONNECTING RAILROAD

MDOT JOB NO. 86173A STRUCTURE NO. R01 of 82-22-54

STRUCTURAL STEEL DETAILS

DATE:	04/16/08
DLZ JOB NO.	0642-6090-00
SHEET NO.	18 OF 60

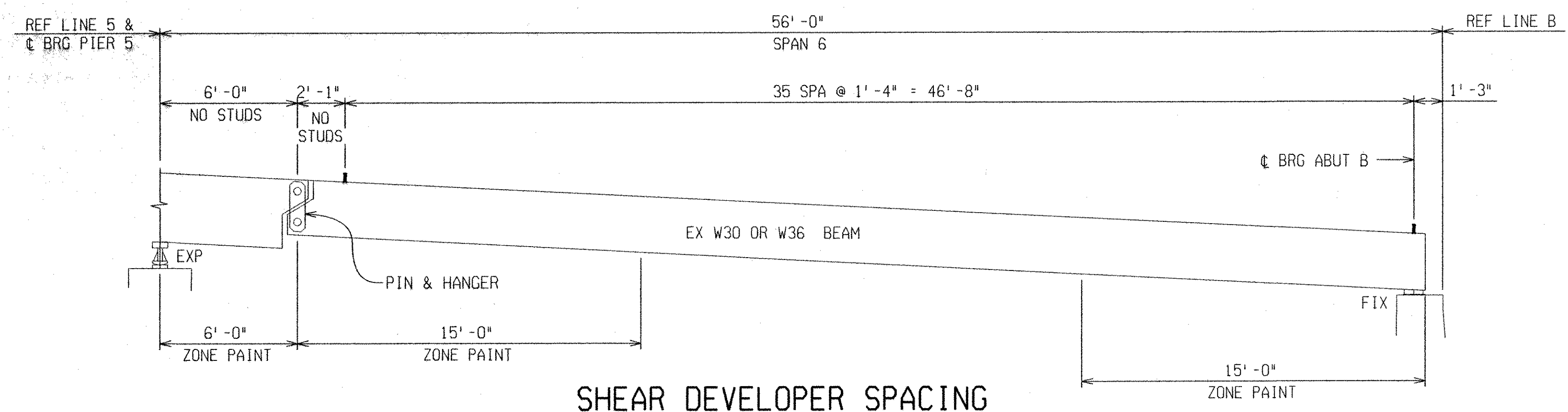
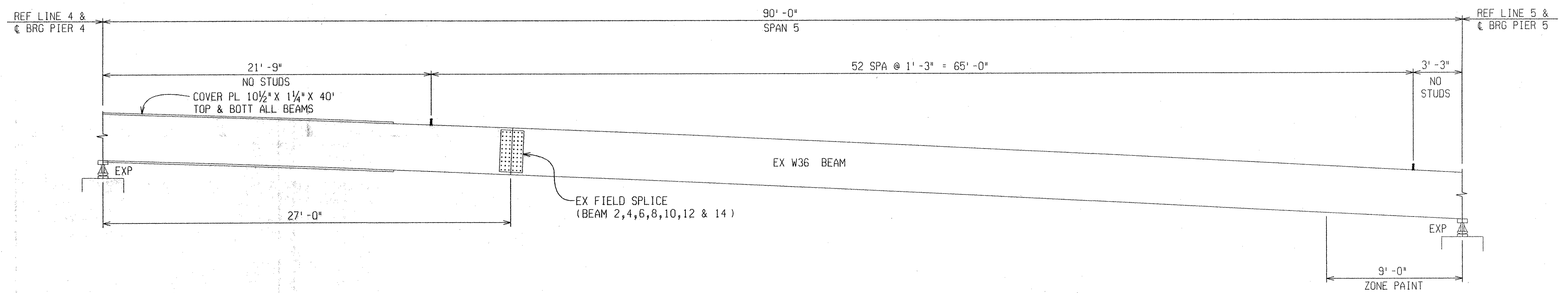
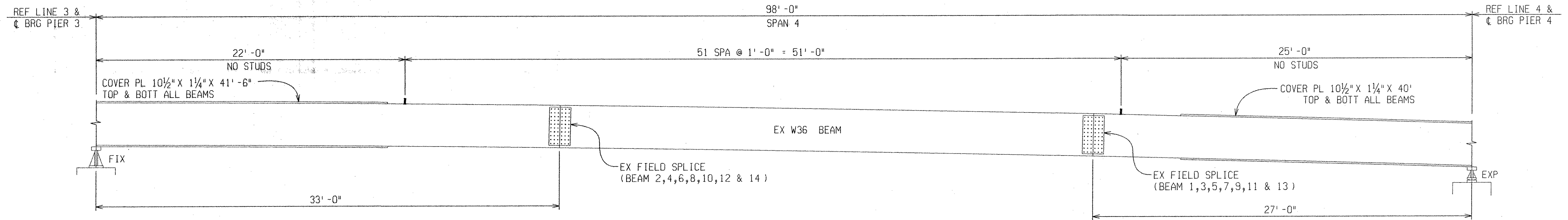

SHEAR DEVELOPER SPACING

MISCELLANEOUS QUANTITIES		
1	LS	Shear Developers (R01 of 82-22-54)
1	LS	Steel Structure, Cleaning, Partial, Type 4 (R01 of 82-22-54)
1	LS	Steel Structure, Coating Partial, Type 4 (R01 of 82-22-54)

REVISIONS	DESCRIPTION	DATE	BY

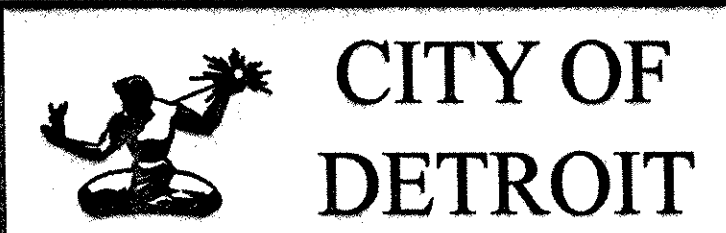

EAST GRAND BLVD OVER
DETROIT CONNECTING RAILROAD
MDOT JOB NO. 86173A STRUCTURE NO. R01 of 82-22-54

STRUCTURAL STEEL DETAILS

DATE: 04/16/08
DLZ JOB NO. 0642-6090-00
SHEET NO. 19 OF 60

DATE: 07/02/07 CORRECTED BY: KCK CHECKED BY: KCK DATE: 06/25/07 DRAWN BY: DW FILE NAME: east_grand_pg0.dgn

MISCELLANEOUS QUANTITIES		
112	Ea	Bushing
4110	Lb	Structural Steel, Furn and Fab, Pin and Hanger
28	Ea	Hanger Assembly, Field Measurement
28	Ea	Hanger Assembly, Rem and Erect
28	Ea	Support, Suspension, Temp

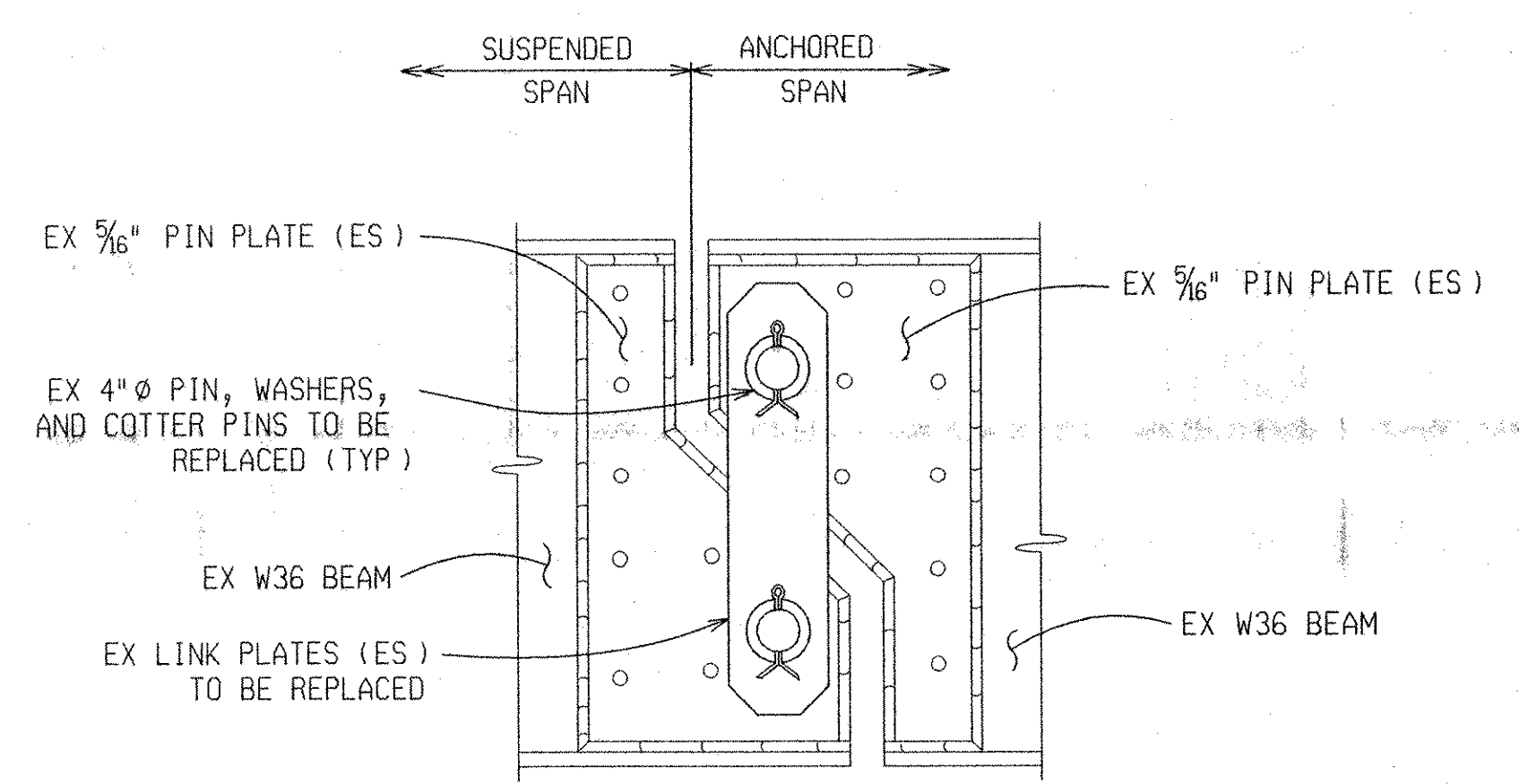

PIN & HANGER ELEVATION (EXISTING)

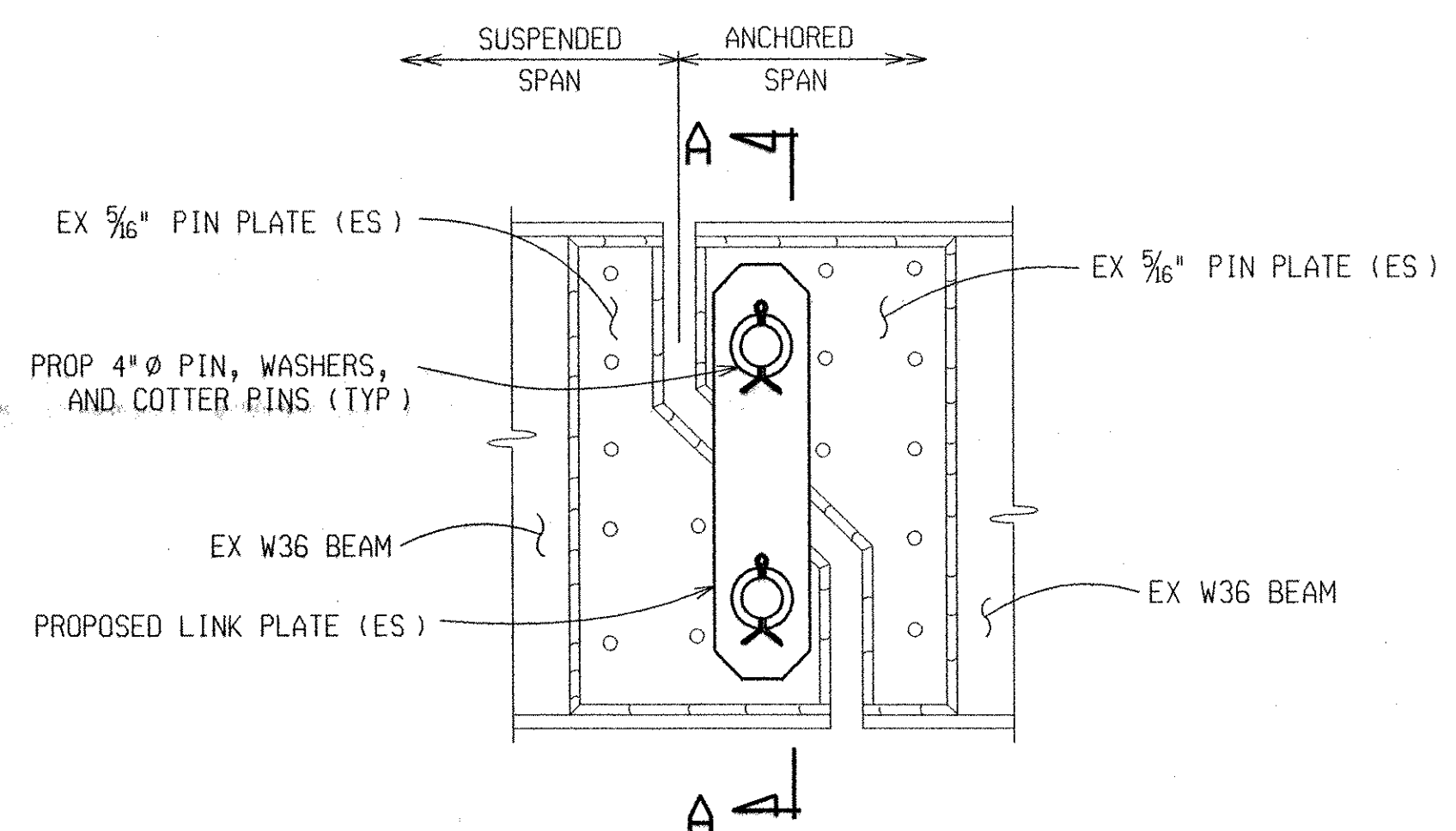

PIN & HANGER ELEVATION (PROPOSED)

NOTES:

THE AREA WITHIN 3 FEET EACH SIDE OF THE CENTERLINE OF THE HANGER ASSEMBLY SHALL BE COATED PRIOR TO INSTALLING THE NEW LINK PLATES AND PINS. PROPOSED LINK PLATES SHALL BE SHOP COATED.

THE PROTECTION OF WORK AND ENVIRONMENT DURING BLAST CLEANING OF WEBS BEHIND AND AROUND HANGER ASSEMBLIES SHALL BE ACCORDING TO SUBSECTION 715 OF THE STANDARD SPECIFICATIONS. (INCLUDED IN THE BID ITEM "Hanger Assembly, Rem and Erect")

WELDING ON EXISTING BEAMS WILL NOT BE PERMITTED.

TEMPORARY SUPPORTS SHALL NOT REMAIN LOADED FOR A PERIOD GREATER THAN FOUR WEEKS.

ALTERNATE DESIGNS OF THE TEMPORARY SUPPORT SHALL BE BASED ON LOADS AS FOLLOWS:
5 TON VERTICAL GIRDER LOAD.

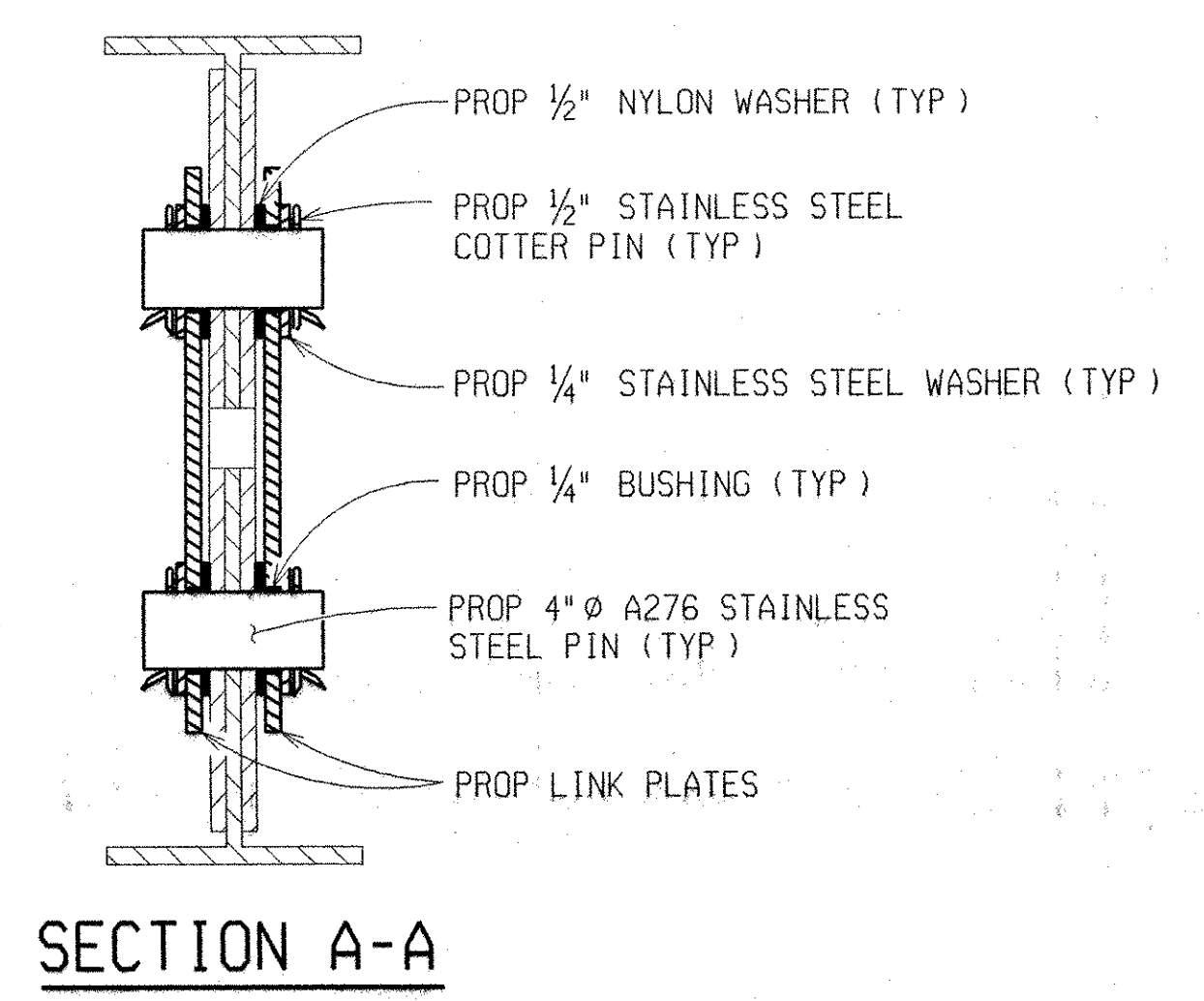

SECTION A-A

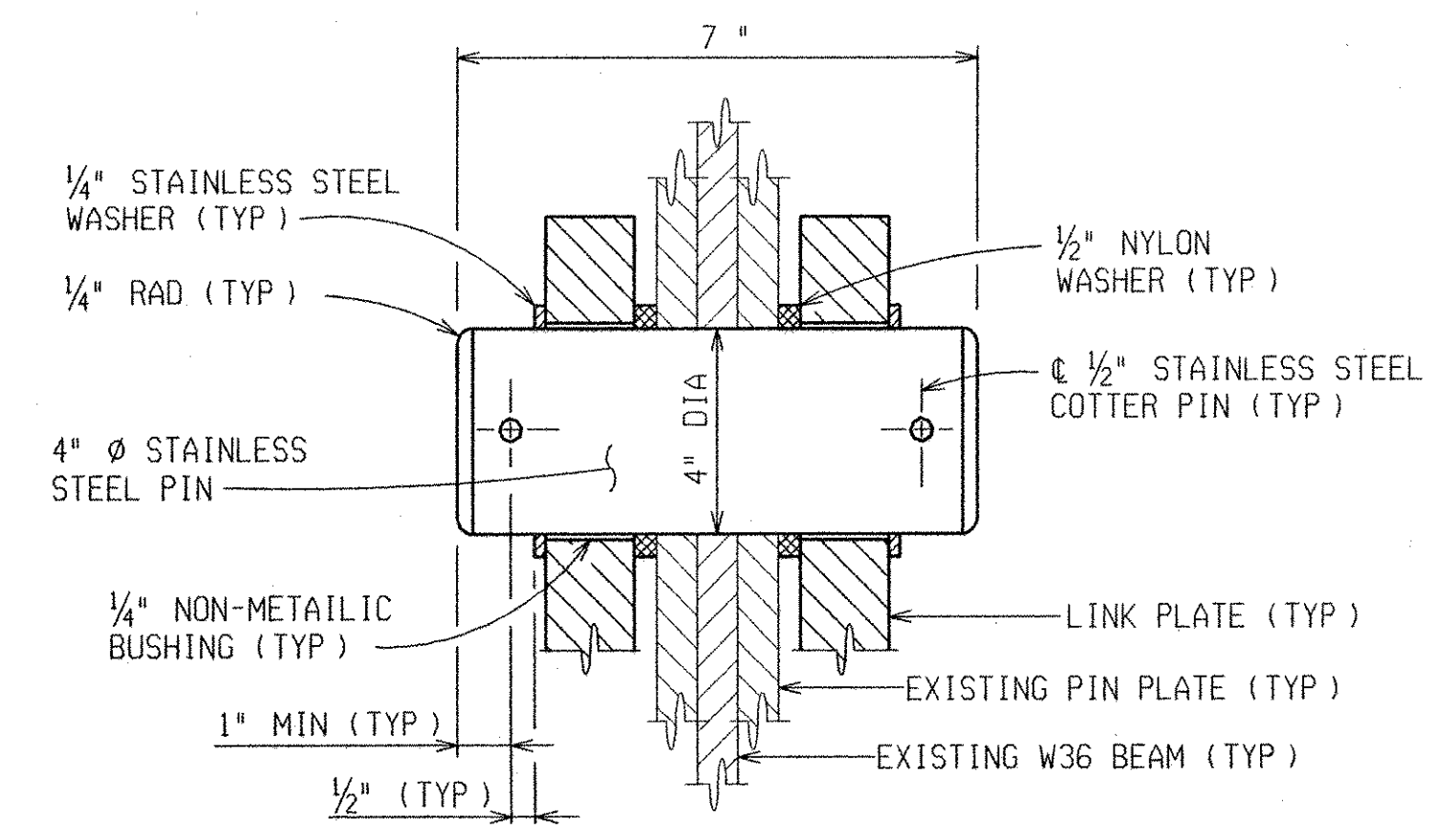

PROPOSED PIN DETAIL
(8 REQ'D)

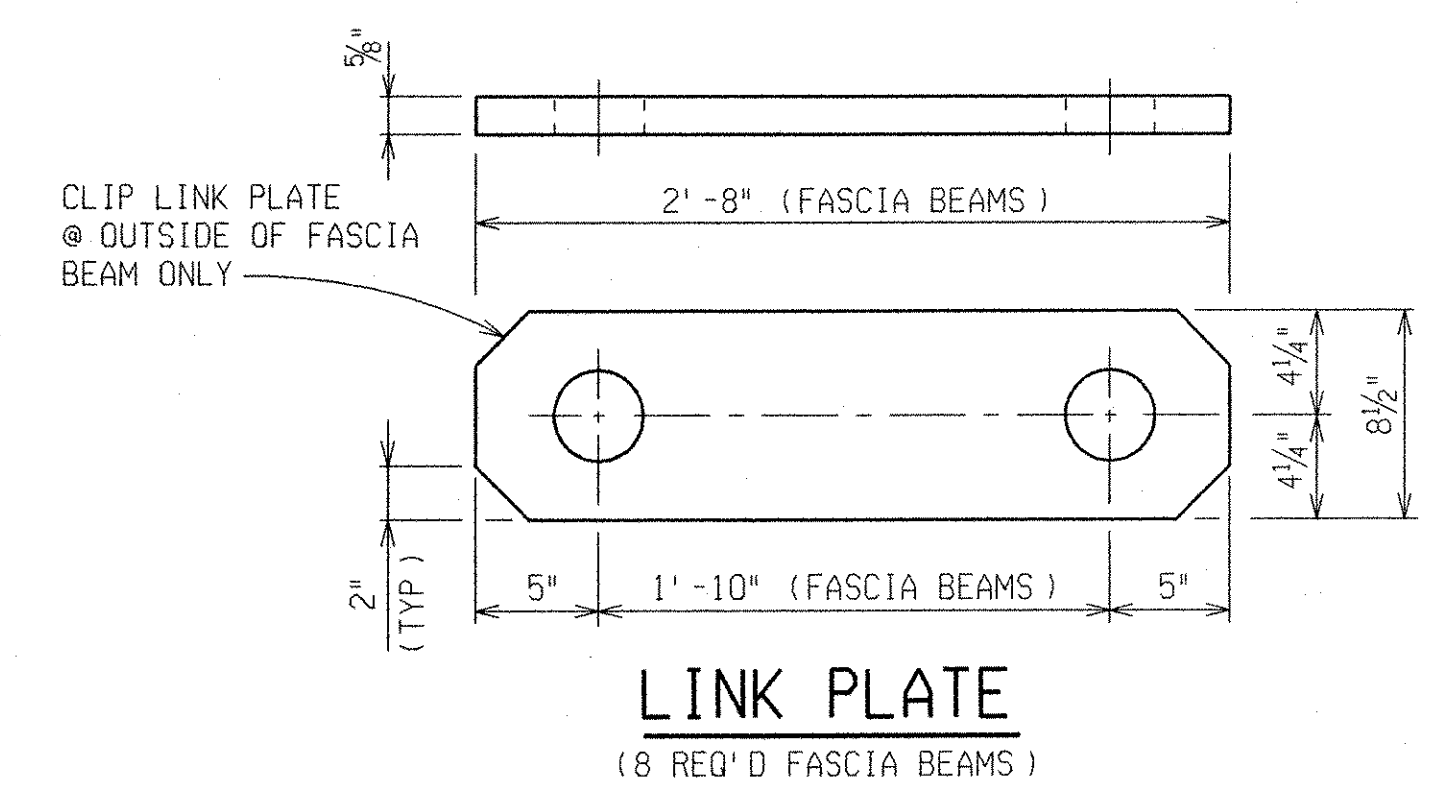

LINK PLATE
(8 REQ'D FASCIA BEAMS)



1/4\"
ALL FASCIA BEAMS
(16 REQ'D)

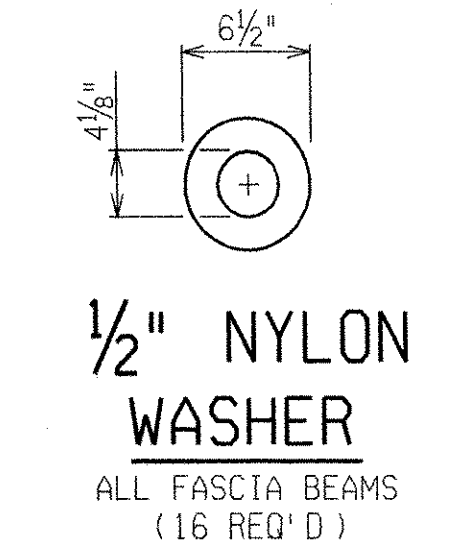

1/2\"
ALL FASCIA BEAMS
(16 REQ'D)

REVISIONS	DESCRIPTION	DATE	BY

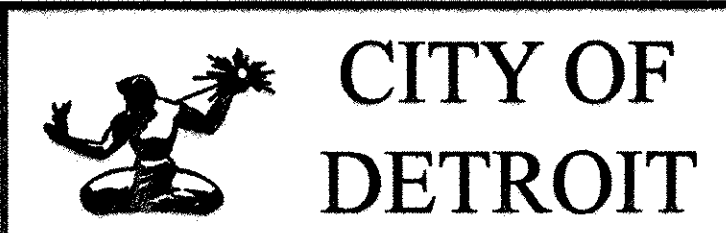

EAST GRAND BLVD OVER
DETROIT CONNECTING RAILROAD
MDOT JOB NO. 86173A STRUCTURE NO. R01 of 82-22-54

PIN AND HANGER DETAILS
(FASCIA BEAMS)

DATE: 04/16/08
DLZ JOB NO. 0642-6090-00
SHEET NO. 20 OF 60

DATE: 07/01/07 CHECKED BY: KCK DATE: 03/19/07 DRAWN BY: JP FILE NAME: east_grand_pr-2.dgn

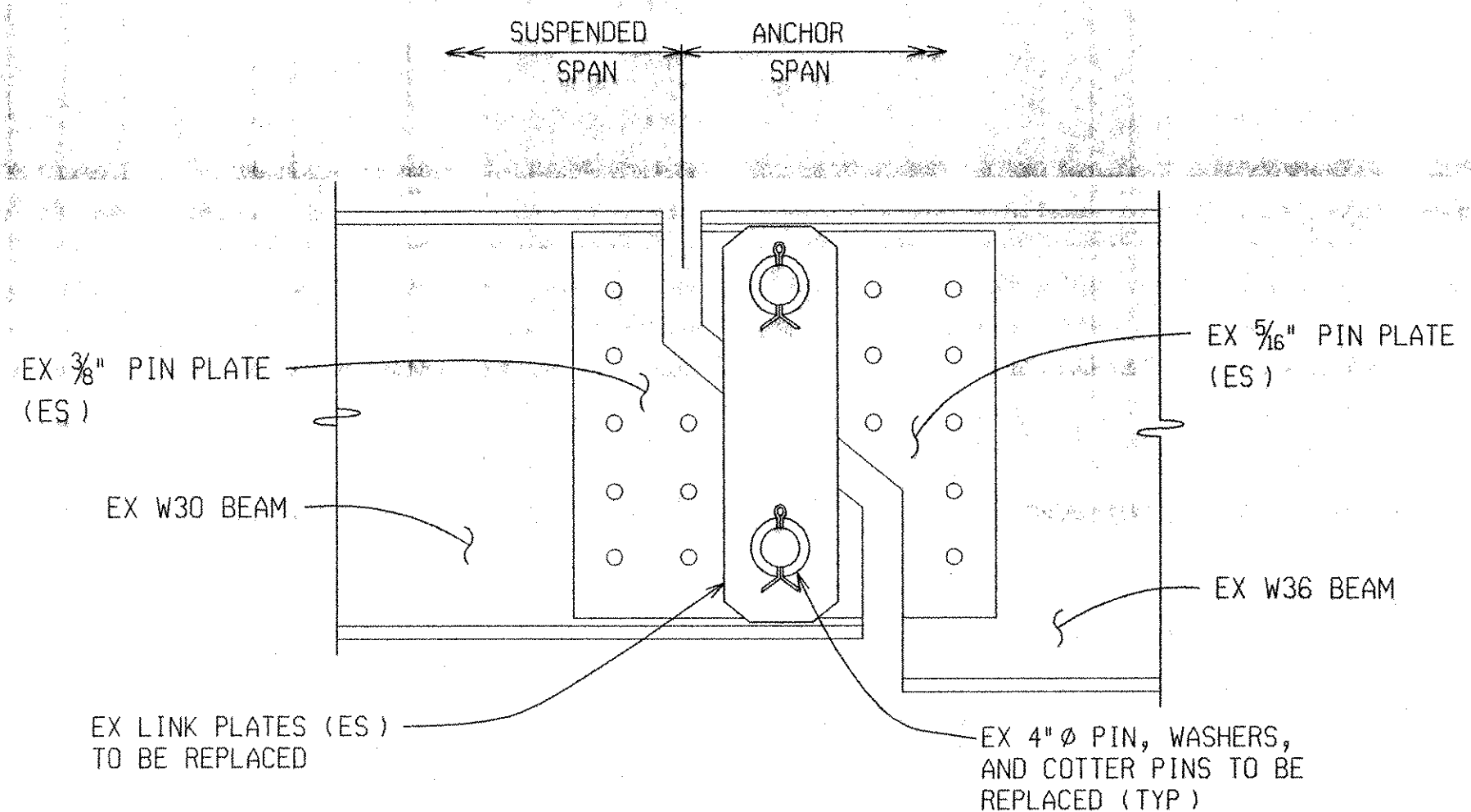

PIN & HANGER ELEVATION (EXISTING)

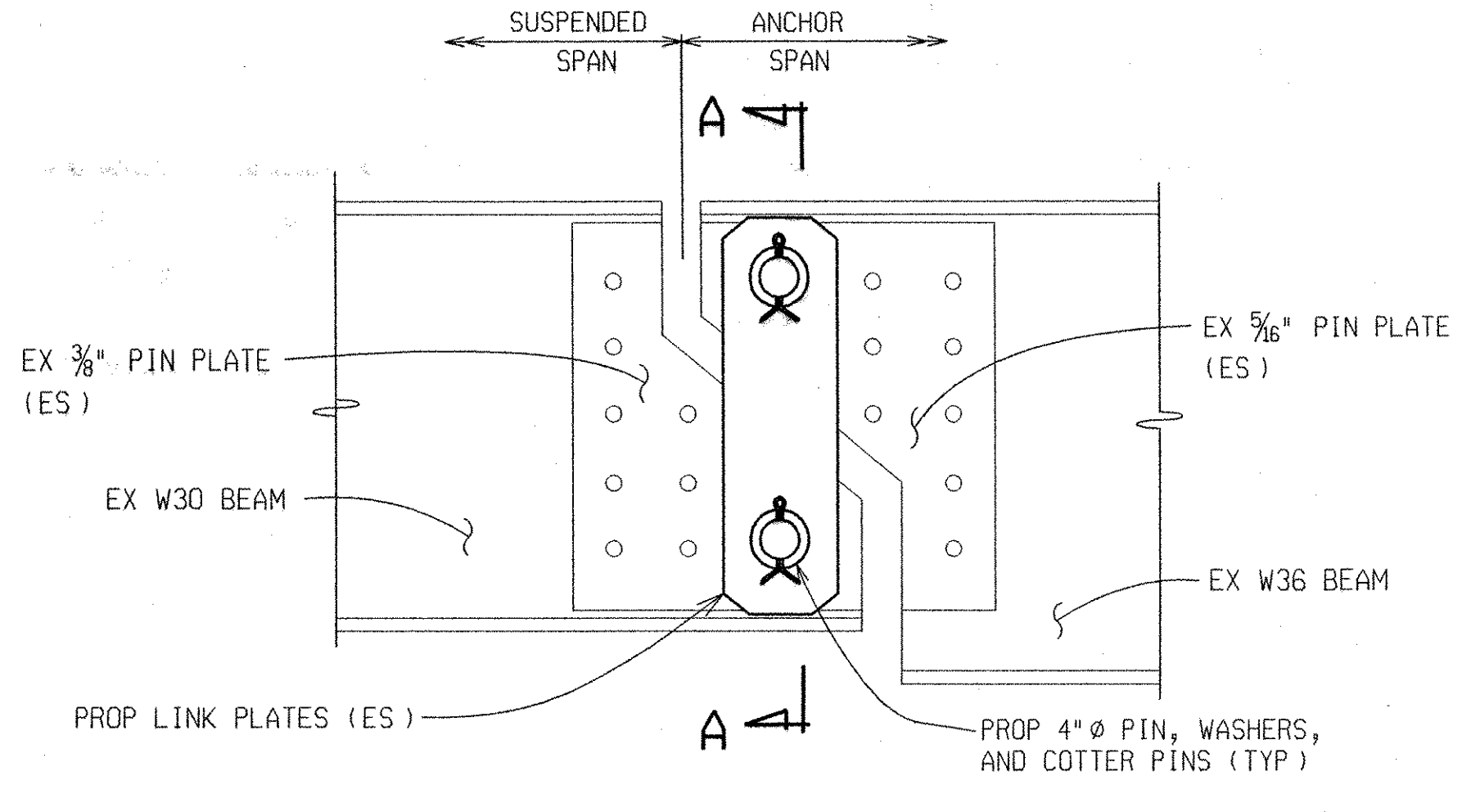

PIN & HANGER ELEVATION (PROPOSED)

NOTES:

THE AREA WITHIN 3 FEET EACH SIDE OF THE CENTERLINE OF THE HANGER ASSEMBLY SHALL BE COATED PRIOR TO INSTALLING THE NEW LINK PLATES AND PINS. PROPOSED LINK PLATES SHALL BE SHOP COATED.

THE PROTECTION OF WORK AND ENVIRONMENT DURING BLAST CLEANING OF WEBS BEHIND AND AROUND HANGER ASSEMBLIES SHALL BE ACCORDING TO SUBSECTION 715 OF THE STANDARD SPECIFICATIONS. (INCLUDED IN THE BID ITEM "Hanger Assembly, Rem and Erect")

WELDING ON EXISTING BEAMS WILL NOT BE PERMITTED.

TEMPORARY SUPPORTS SHALL NOT REMAIN LOADED FOR A PERIOD GREATER THAN FOUR WEEKS.

ALTERNATE DESIGNS OF THE TEMPORARY SUPPORT SHALL BE BASED ON LOADS AS FOLLOWS:
5 TON VERTICAL GIRDER LOAD.

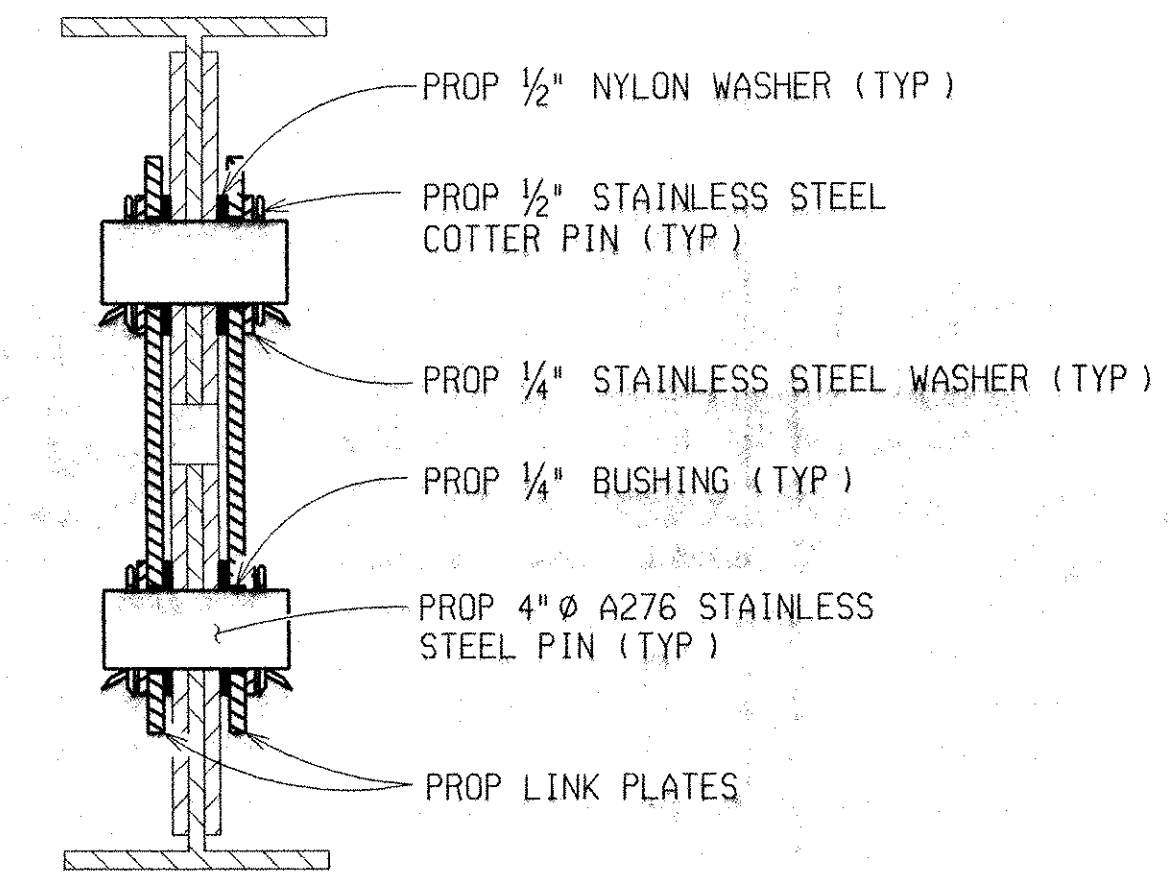

SECTION A-A

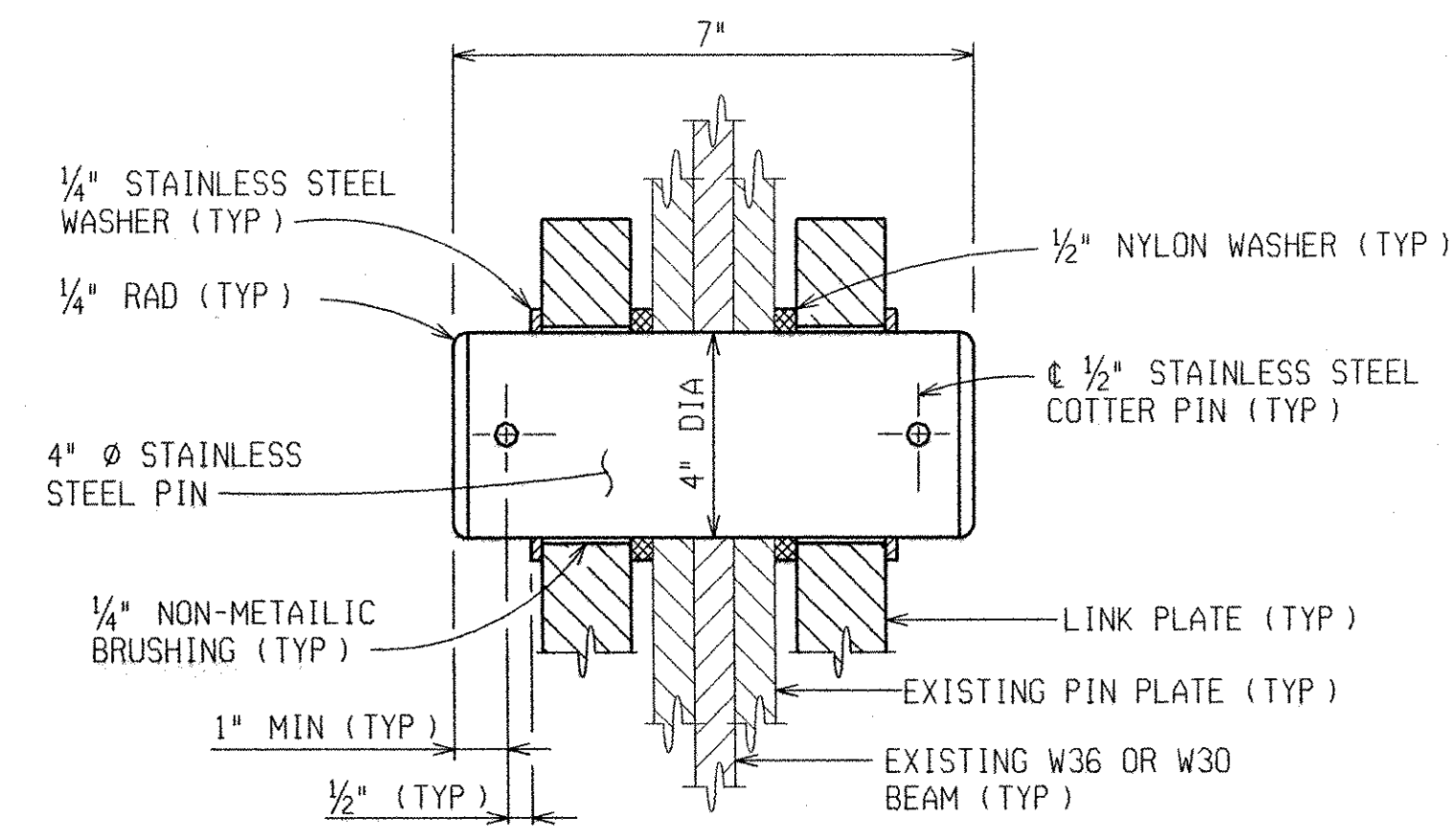

PROPOSED PIN DETAIL
(48 REQ'D)

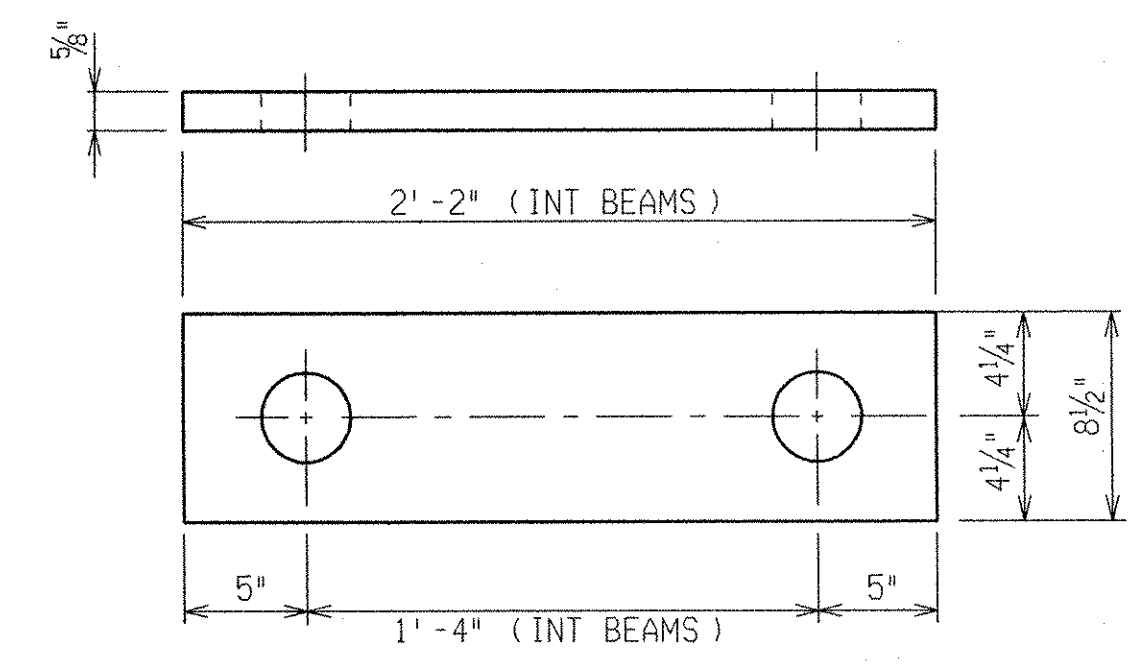

LINK PLATE
(48 REQ'D INTERIOR BEAMS)

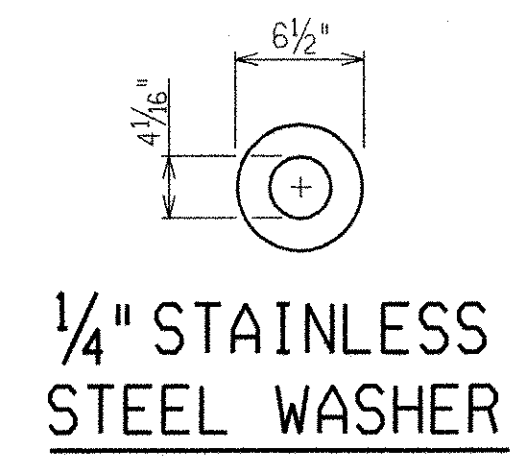

1/4\"
ALL INTERIOR BEAMS
(96 REQ'D)

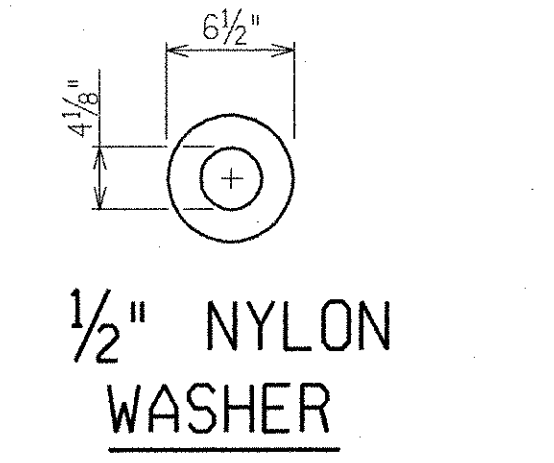

1/2\"
ALL INTERIOR BEAMS
(INCLUDED IN THE PAY ITEM
"Structural Steel, Furn and Fab, Pin
and Hanger")
(96 REQ'D)

REVISIONS	DESCRIPTION	DATE	BY

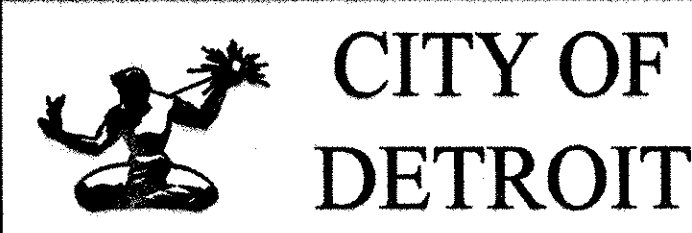

EAST GRAND BLVD OVER
DETROIT CONNECTING RAILROAD
MDOT JOB NO. 86173A STRUCTURE NO. R01 of 82-22-54

**PIN AND HANGER DETAILS
(INTERIOR BEAMS)**

DATE:	04/16/08
DLZ JOB NO.	0642-6090-00
SHEET NO.	21 OF 60

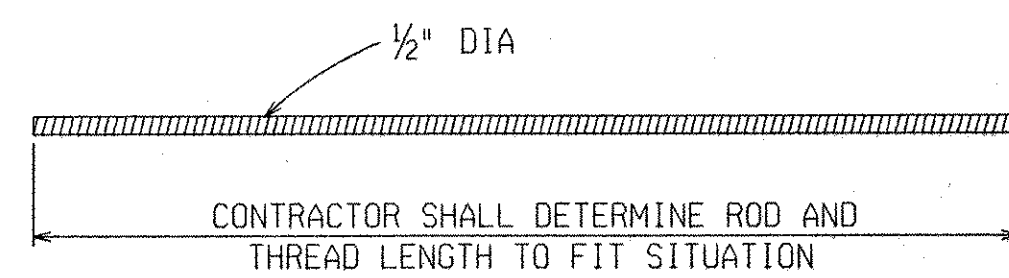
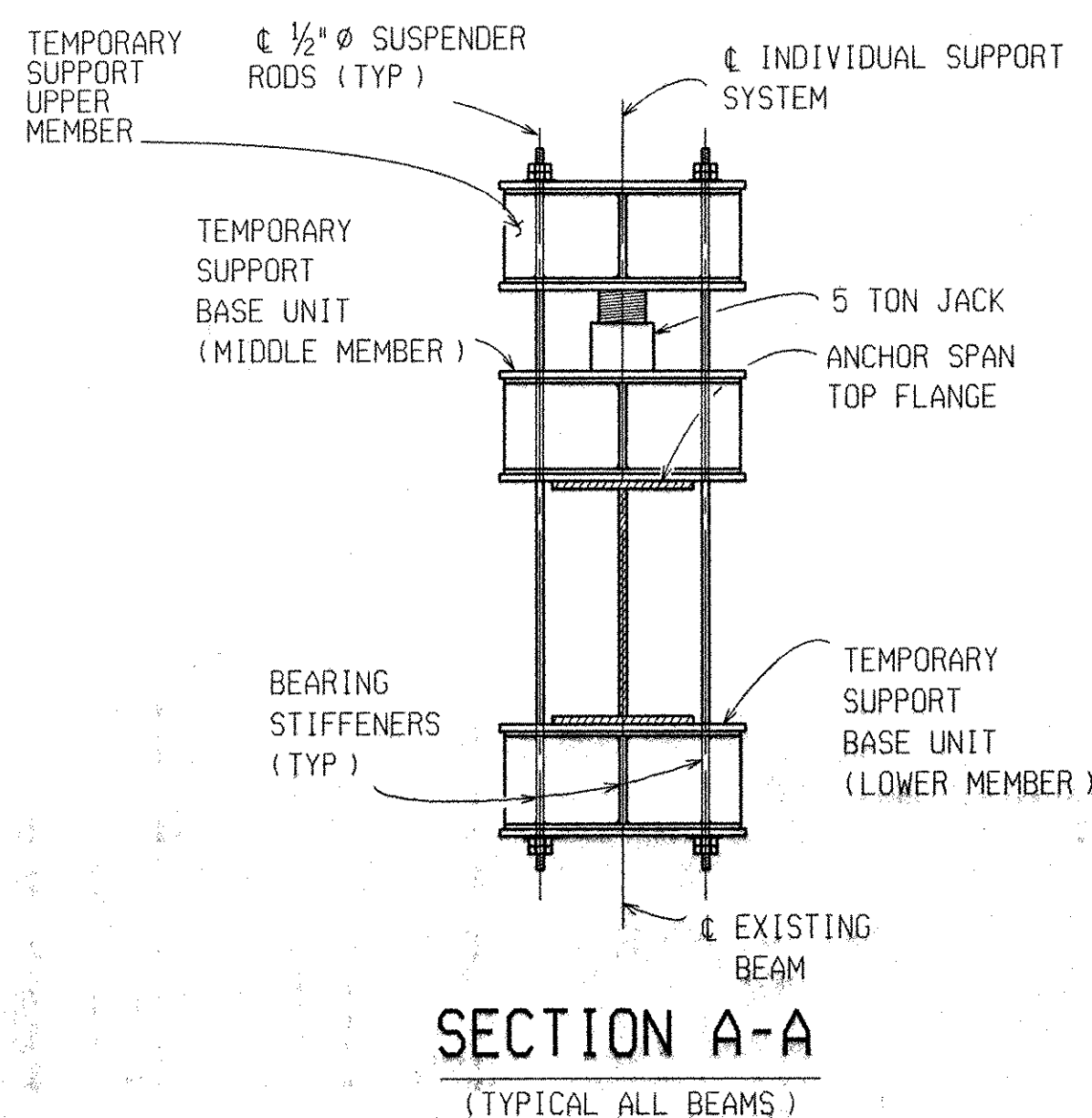

SUSPENDER ROD DETAIL

2 REQUIRED PER ASSEMBLY W/8 HEAVY HEX NUTS
& 4 HARDENED WASHER PER ROD

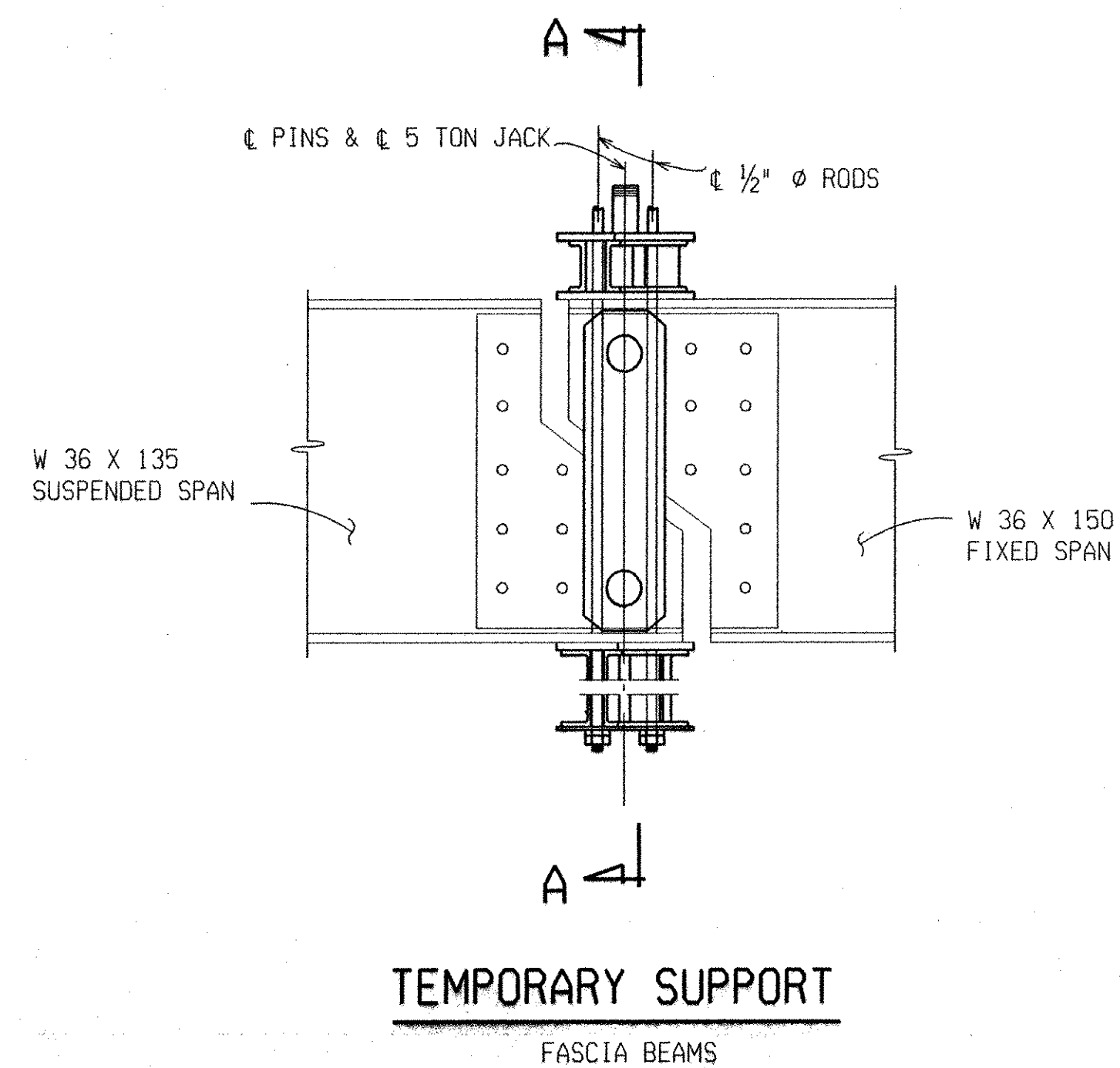

TEMPORARY SUPPORT
FASCIA BEAMS

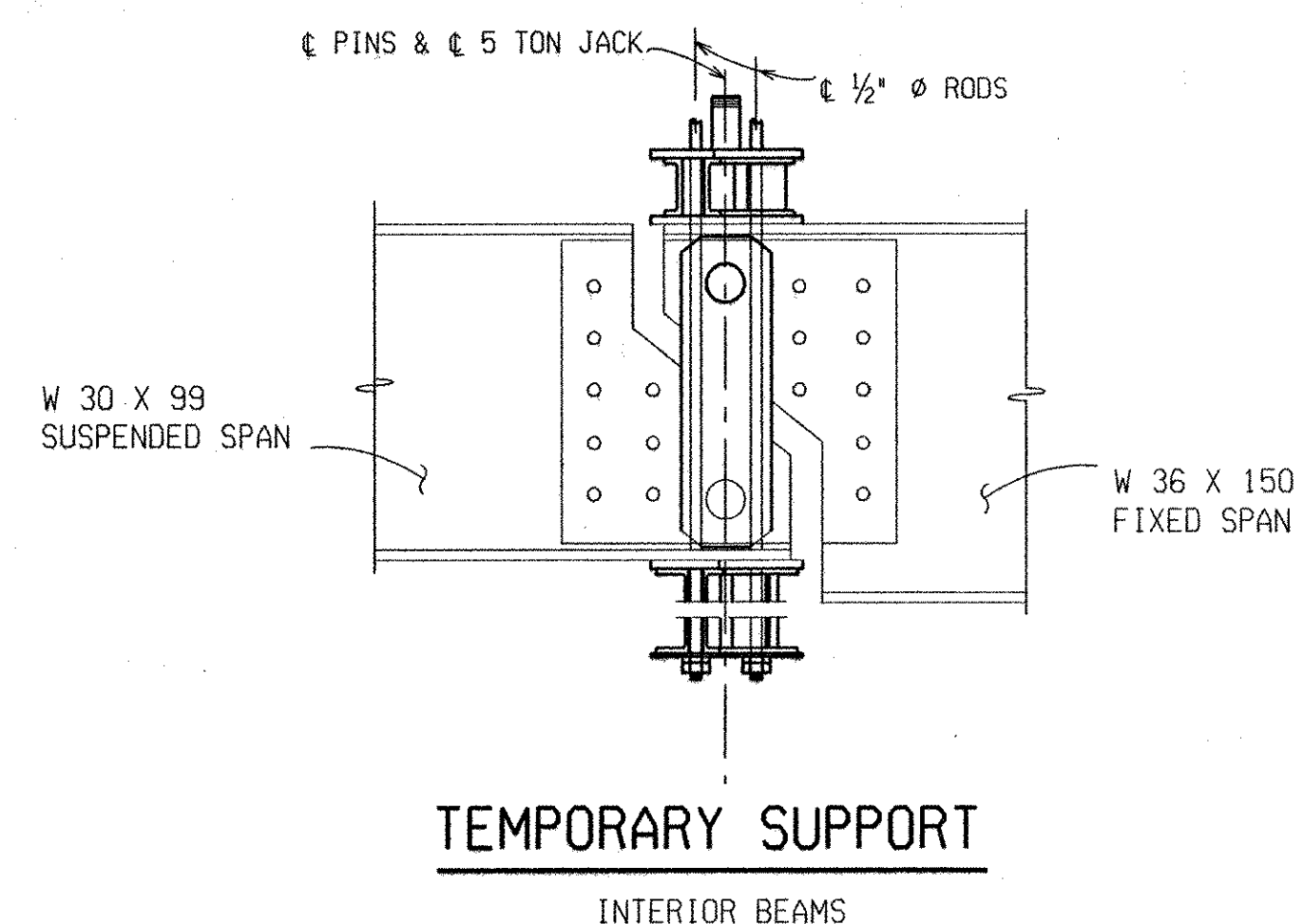

TEMPORARY SUPPORT
INTERIOR BEAMS

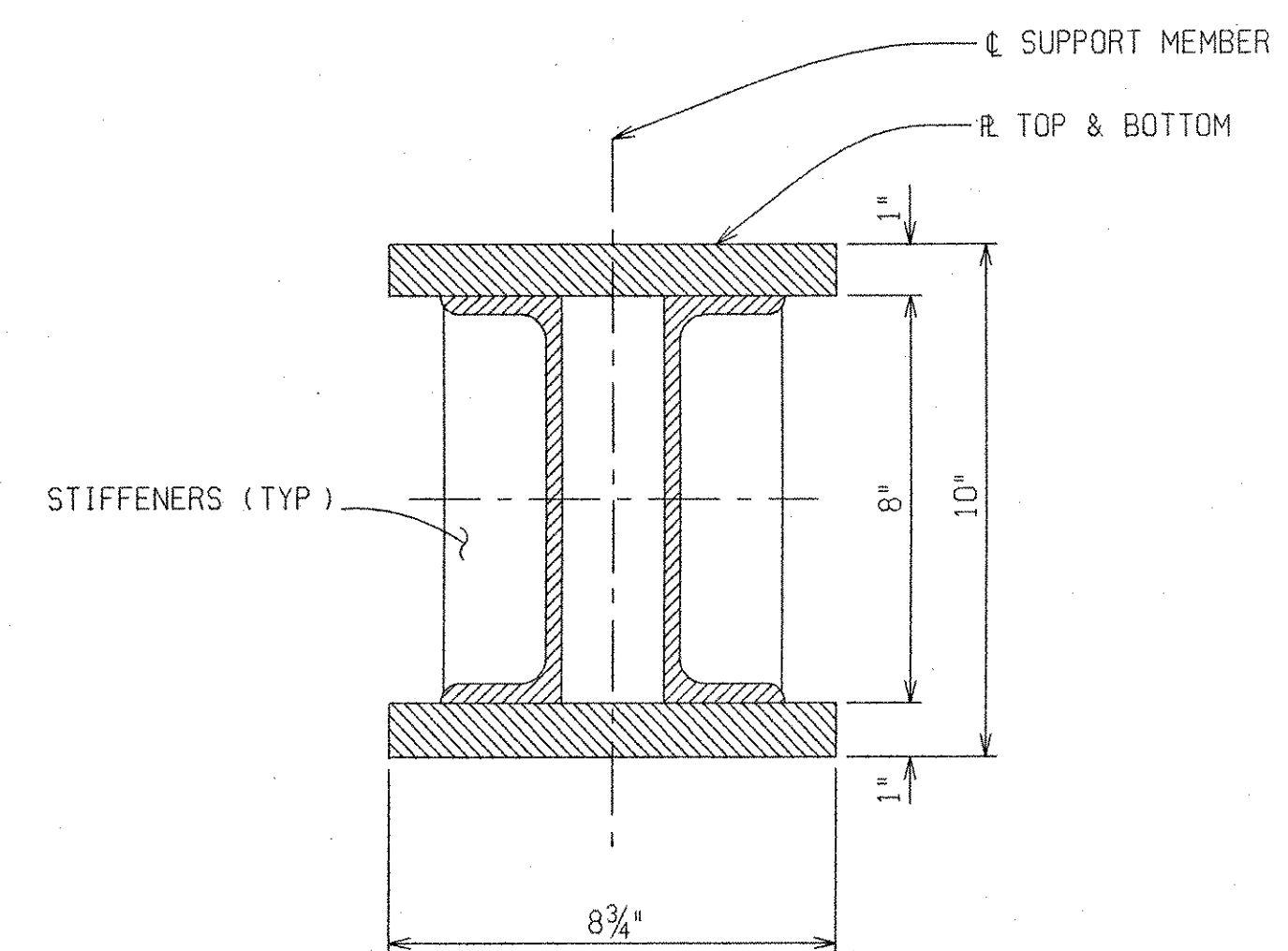

SECTION C-C

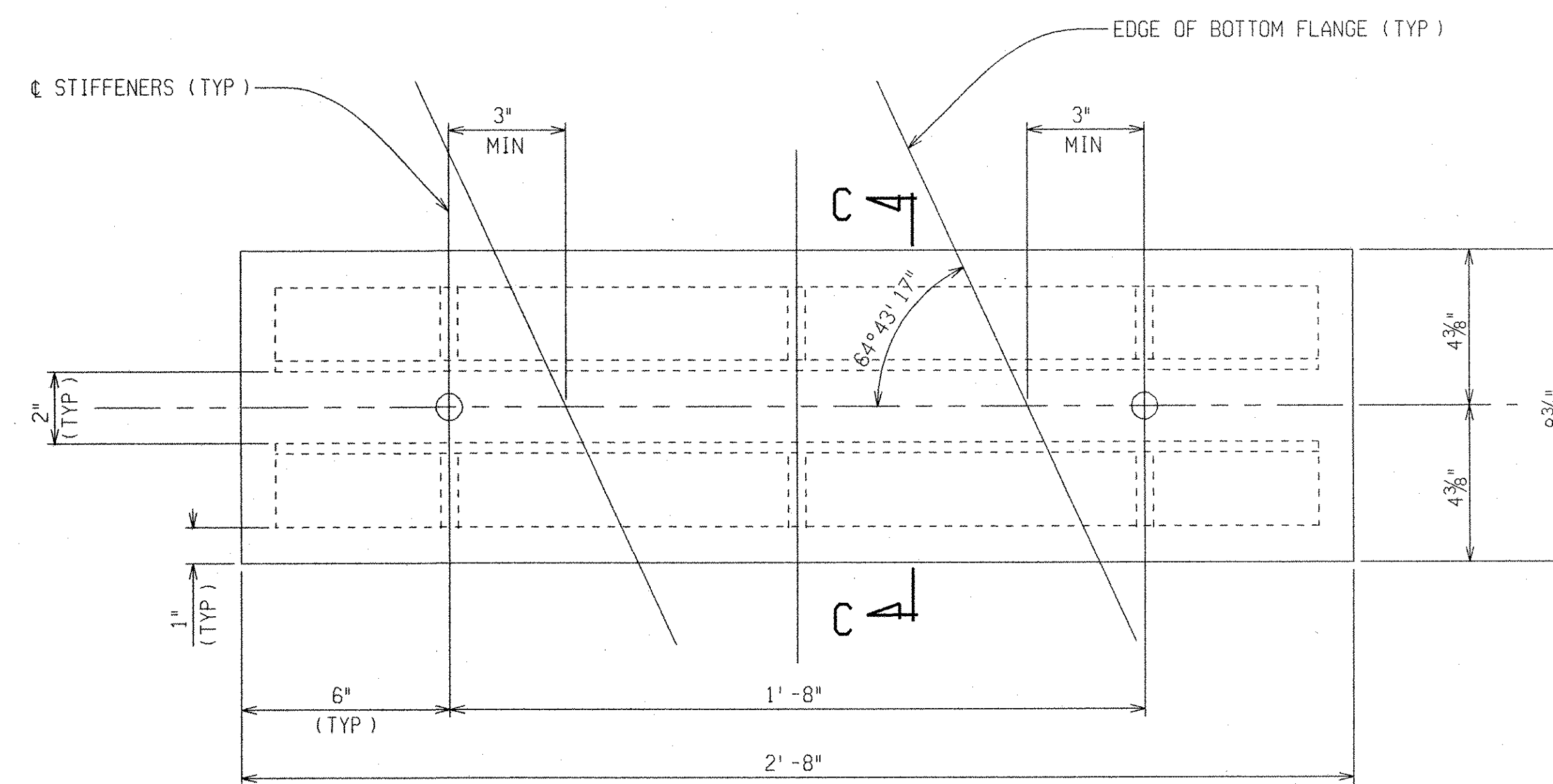

PLAN

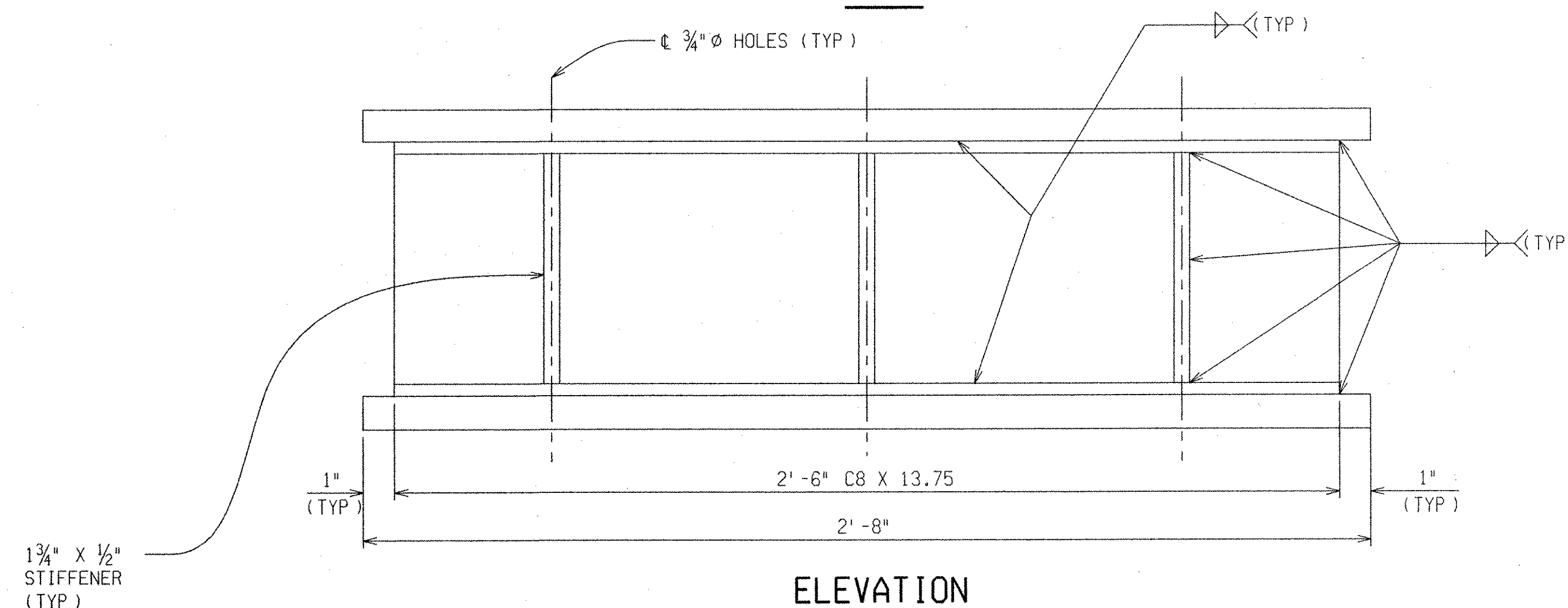

ELEVATION
ASSEMBLY MEMBER DETAILS

(OMIT OUTSIDE STIFFENERS ON MIDDLE MEMBERS ONLY)

REVISIONS	DESCRIPTION	DATE	BY



EAST GRAND BLVD OVER
DETROIT CONNECTING RAILROAD
MDOT JOB NO. 86173A STRUCTURE NO. R01 of 82-22-54

PIN AND HANGER DETAILS

DATE: 04/16/08
DLZ JOB NO. 0642-6090-00
SHEET NO. 22 OF 60

NOTES:

JOINT TYPES

THE EXPANSION JOINT DEVICE SHALL BE OF A TYPE THAT INCLUDES A CONTINUOUS NEOPRENE (OR EQUIVALENT) SEAL ACROSS THE DECK. UNLESS OTHERWISE NOTED ON THE PLANS, THE CONTRACTOR HAS THE OPTION OF USING ANY OF THE DEVICES LISTED BELOW:

DEVICE	MANUFACTURER
WABO STRIP SEAL - TYPE M	WATSON-BOWMAN & ACME, INC.
WABO STRIP SEAL - TYPE A	WATSON-BOWMAN & ACME, INC.
STEELEX-SSA2	D.S. BROWN
STEELEX-SSCM	D.S. BROWN
ONFLEX 40 SS	STRUCTURAL RUBBER PRODUCTS CO.

THE MODEL OF THE JOINT TYPE SELECTED SHALL BE SUITABLE TO ACCOMMODATE THE TOTAL MOVEMENT NOTED ON THE PLANS.

COMPLETE WORKING DRAWINGS OF ALL DETAILS OF FABRICATION OF THE EXPANSION JOINT DEVICE SHALL BE SUBMITTED FOR REVIEW IN ACCORDANCE WITH STANDARD SPECIFICATION 104.02. THIS REQUIREMENT IS WAIVED FOR EXPANSION JOINT DEVICES FOR WHICH A SET OF STANDARD INSTALLATION DETAILS HAS BEEN APPROVED. STANDARD INSTALLATION DETAILS CAN BE OBTAINED FROM THE DESIGN SUPPORT AREA.

FABRICATION AND INSTALLATION

THE EXPANSION JOINT SHALL BE SHOP FABRICATED TO CONFORM TO THE CONTOUR OF THE BRIDGE DECK, BARRIERS, ETC. IT SHALL BE INSTALLED IN ACCORDANCE WITH MANUFACTURER'S RECOMMENDATIONS SUBJECT TO NOTES HEREIN AND THE APPROVAL OF THE ENGINEER.

THE TOP OF THE EXPANSION JOINT DEVICE SHALL BE SET 1/8" - 1/4" BELOW THE CONCRETE SLAB (PAVEMENT) WITH A TOLERANCE OF ± 1/8".

THE STEEL ANCHORAGE FOR STRIP SEAL GLANDS SHALL BE HOT DIP GALVANIZED IN ACCORDANCE WITH SUBSECTION 707.03C.16 OF THE STANDARD SPECIFICATIONS.

THE AREA OF THE STEEL ANCHORAGE AND SEALING GLAND WHICH WILL BE IN CONTACT WITH A SEALANT, OR LUBRICANT-ADHESIVE SHALL BE CLEANED WITH TOLUENE OR OTHER APPROVED SOLVENT.

WHERE THE SEALING GLAND IS LOCKED INTO A STEEL ANCHORAGE, A LUBRICANT-ADHESIVE CONFORMING TO STANDARD SPECIFICATION 914.04D SHALL BE REQUIRED BETWEEN THE SEAL AND STEEL ANCHORAGE.

IN THE EVENT THAT SPLICING IS REQUIRED OF THE SEALING GLAND, IT SHALL BE SPLICED BY AN APPROVED METHOD (SUCH AS COLD VULCANIZATION) BY A TRAINED REPRESENTATIVE OF THE MANUFACTURER.

DETAILS AT CURBS OR BARRIERS

THE DETAILS ON THIS SHEET SHOW AN APPROVED MEANS OF TERMINATING THE EXPANSION JOINT DEVICE AT CURBS OR BARRIERS. VARIATIONS OR ALTERNATIVE SCHEMES WILL BE CONSIDERED AND MAY BE USED IF APPROVED BY THE ENGINEER.

MATERIALS

THE COST OF ALL MATERIALS AND LABOR REQUIRED FOR PROPER INSTALLATION OF THE EXPANSION JOINT AND THE TERMINAL ASSEMBLIES AT THE CURBS, SIDEWALKS, OR BARRIERS IS INCLUDED IN THE PAYMENT FOR THE EXPANSION JOINT DEVICE.

STRUCTURE NUMBER	ANGLE OF CROSSING TO NEAREST 10°	LOCATION OF JOINT	MIN. TOT. TRAVEL ALONG CENTERLINE OF BRIDGE	REQUIRED LENGTH OF EXPANSION JOINT DEVICE
R01	90°	SPAN 1 EB	3/16"	43' - 8"
R01	90°	SPAN 1 WB	3/16"	43' - 8"
R01	90°	SPAN 6 EB	3/16"	43' - 8"
R01	90°	SPAN 6 WB	3/16"	43' - 8"

QUANTITY		
ITEM	UNIT	AMOUNT
Expansion Joint Device	Ft	175

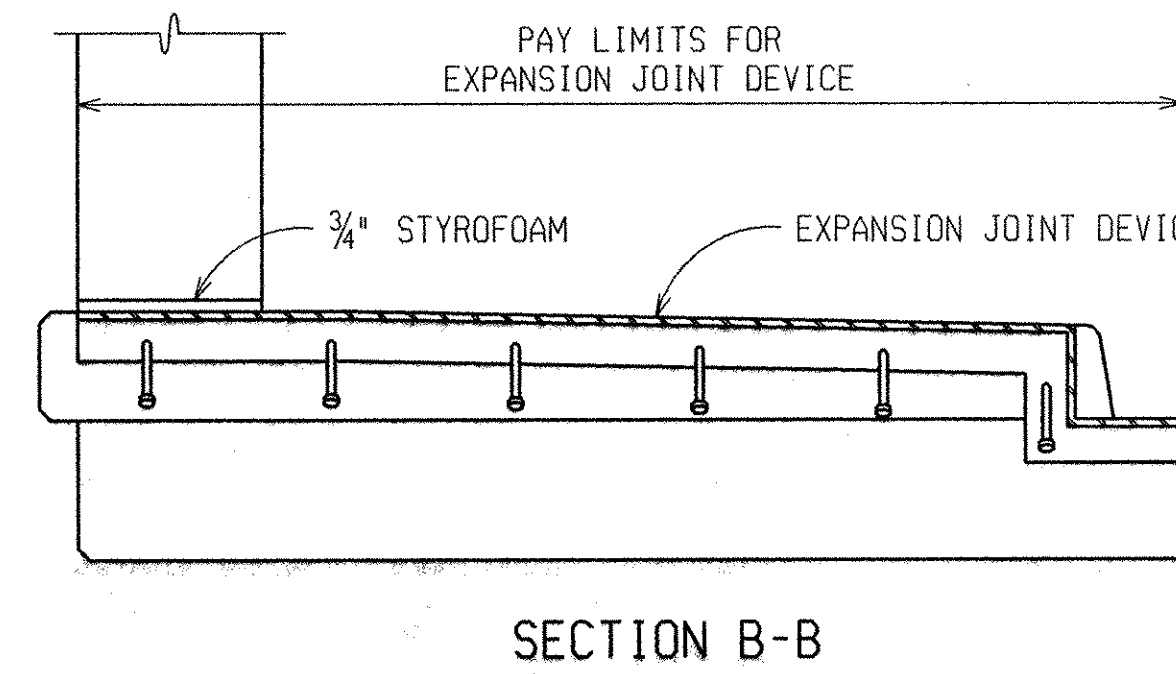
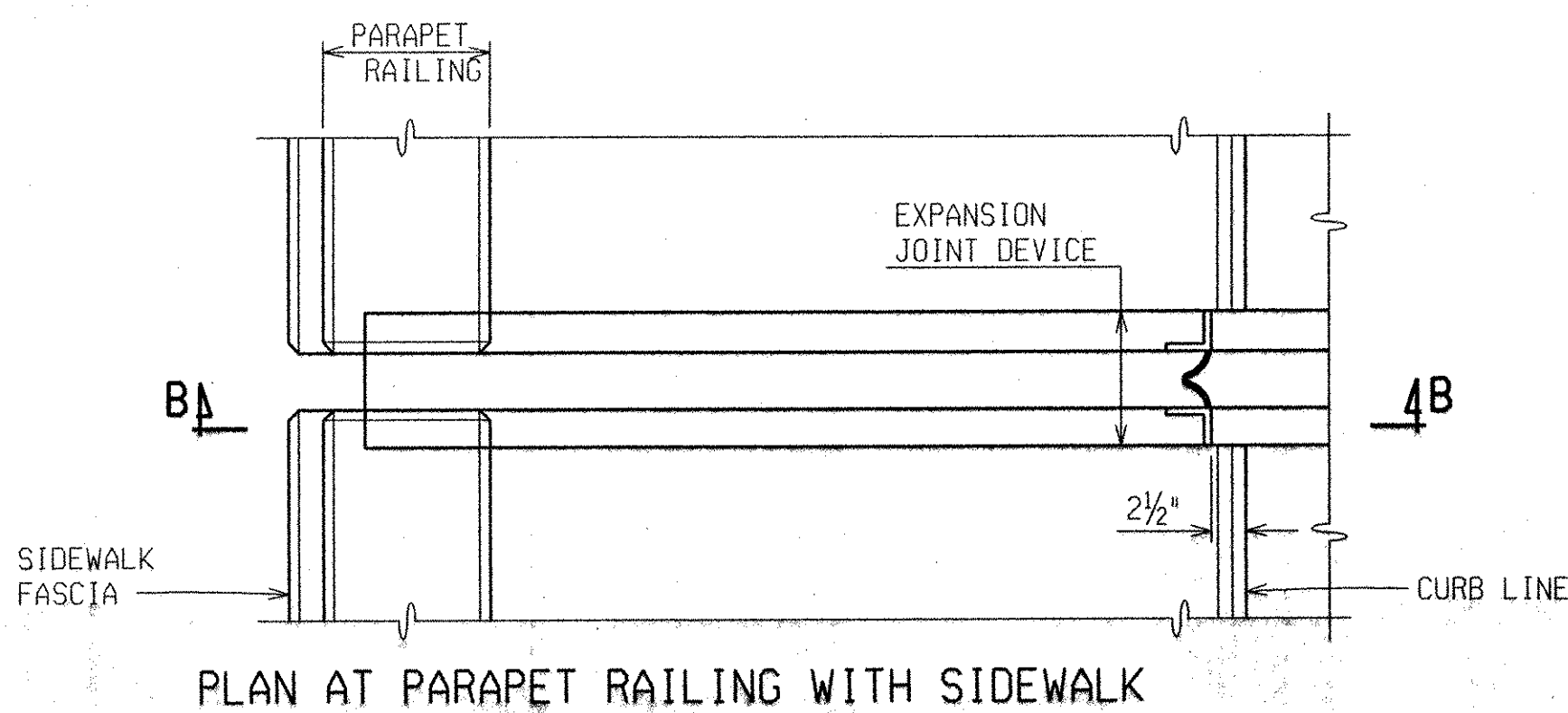
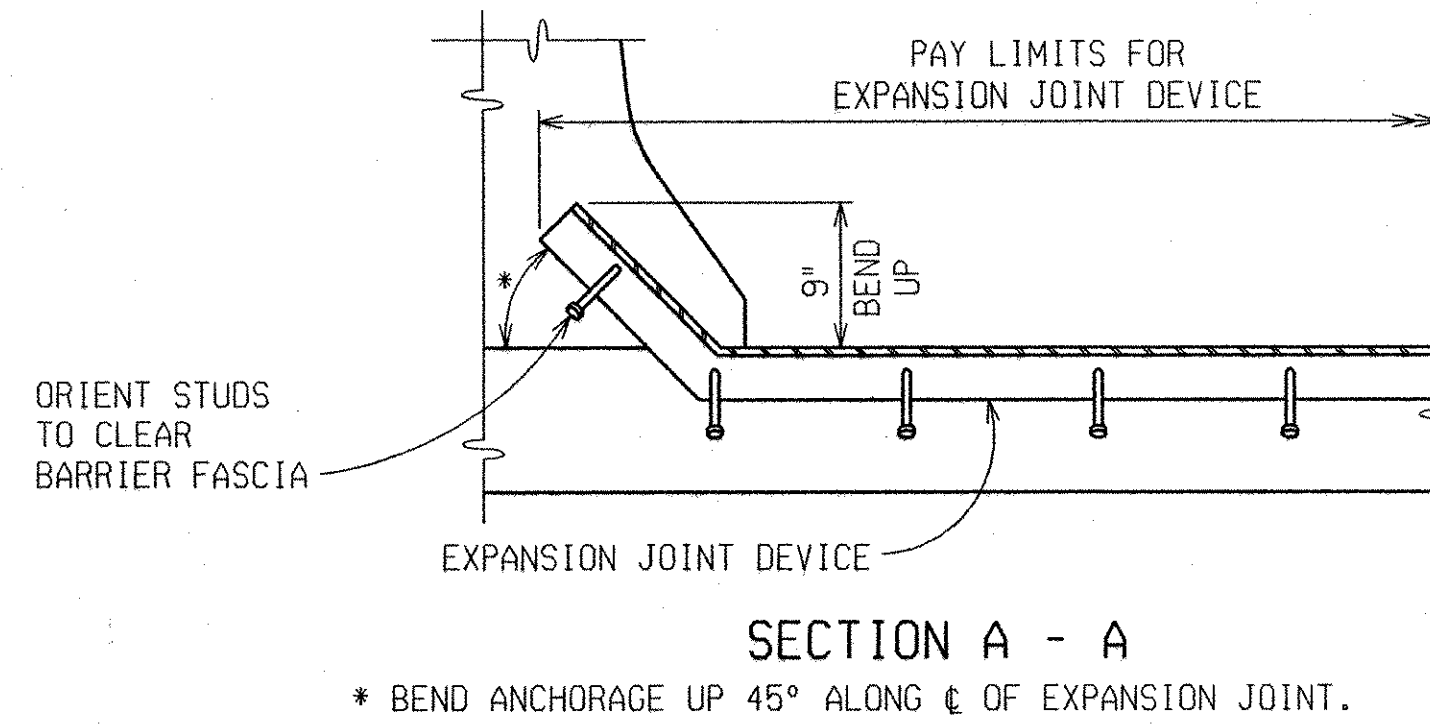
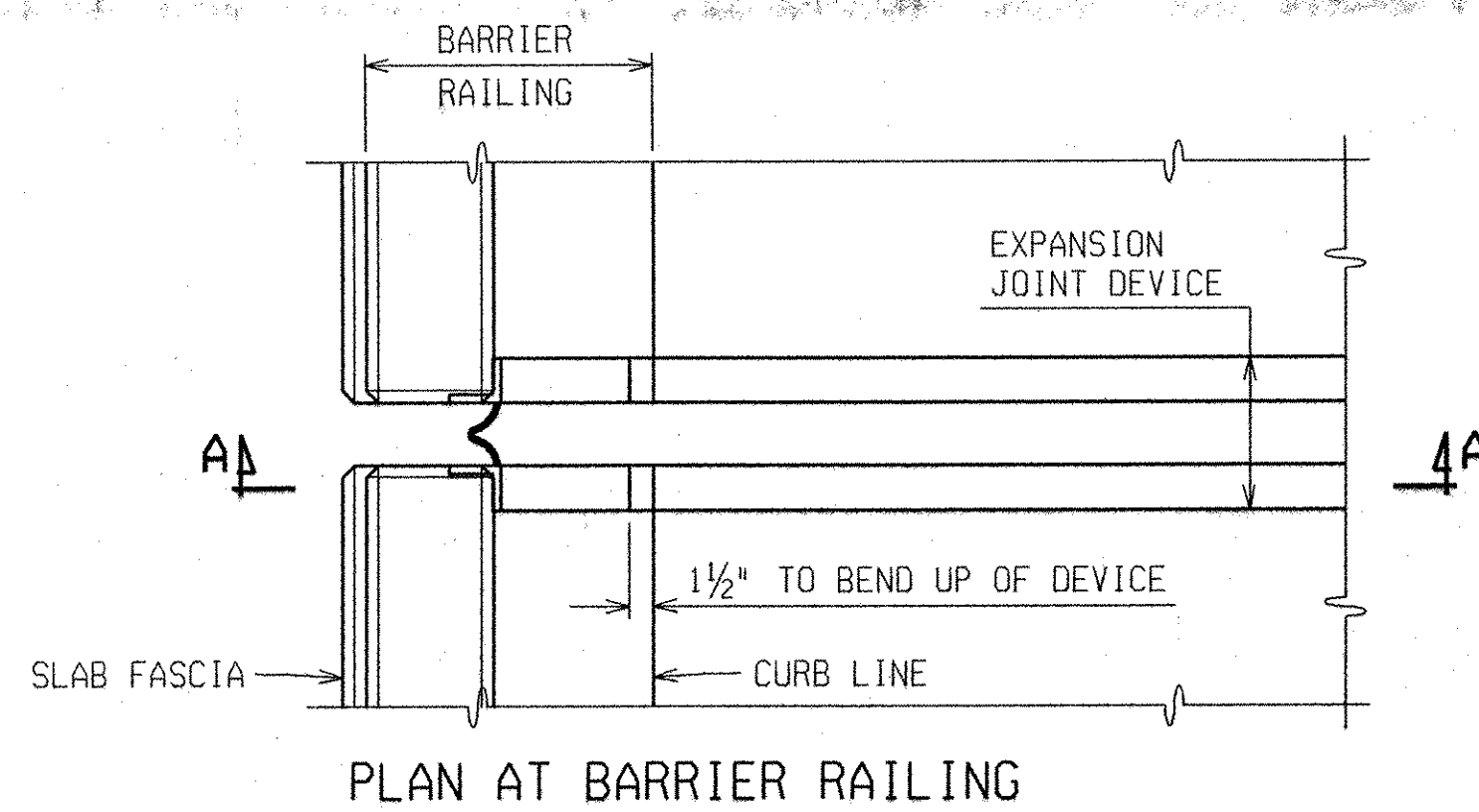

REVISIONS	DESCRIPTION	DATE	BY



EAST GRAND BLVD OVER
DETROIT CONNECTING RAILROAD
MDOT JOB NO. 86173A STRUCTURE NO. R01 of 82-22-54

EXPANSION JOINT DETAILS

DATE: 04/16/08
DLZ JOB NO. 0642-6090-00
SHEET NO. 23 OF 60

268'-7 1/4" REF PT A TO REF PT B

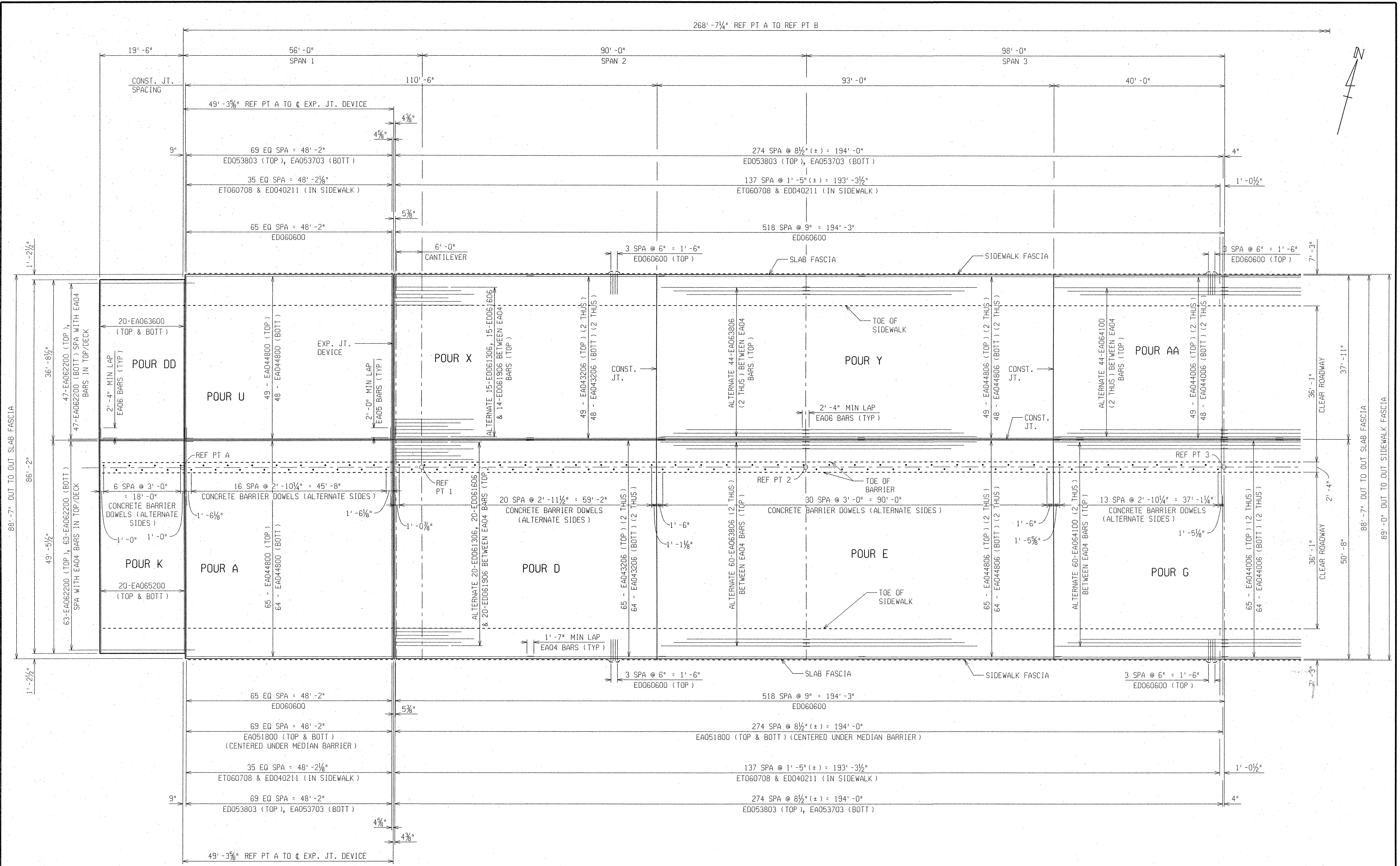
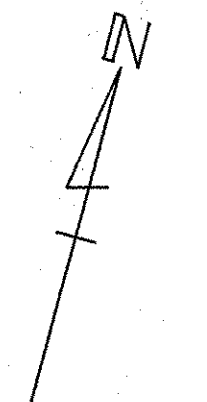

REVISIONS	DESCRIPTION	DATE	BY



EAST GRAND BLVD OVER
DETROIT CONNECTING RAILROAD

MDOT JOB NO. 86173A STRUCTURE NO. R01 of 82-22-54

SUPERSTRUCTURE DETAILS

DATE: 04/16/08
DLZ JOB NO. 0642-6090-00
SHEET NO. 24 OF 60

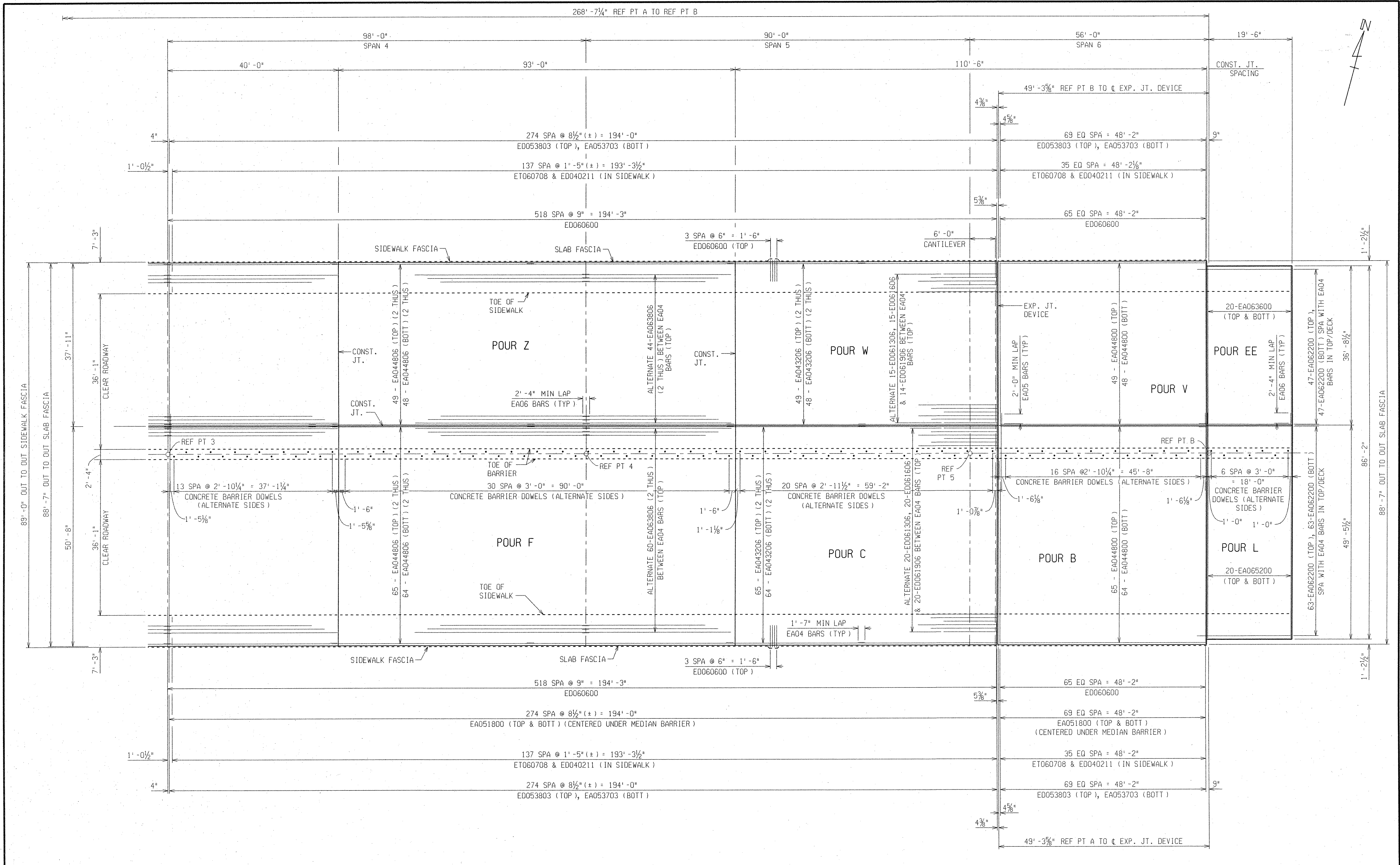

DATE: 07/02/07

DATE: 07/02/07

CHECKED BY: KCK

DATE: 06/27/07

DRAWN BY: DAF

FILE NAME: east_grand_dk2.dgn

REVISIONS	DESCRIPTION	DATE	BY

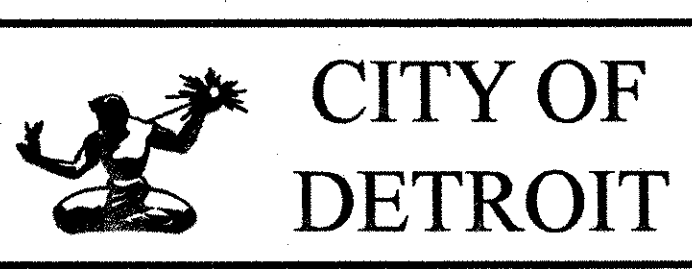

EAST GRAND BLVD OVER
DETROIT CONNECTING RAILROAD

MDOT JOB NO. 86173A STRUCTURE NO. R01 of 82-22-54

SUPERSTRUCTURE DETAILS

DATE: 04/16/08
DLZ JOB NO. 0642-6090-00
SHEET NO. 25 OF 60

DATE: 07/06/07

CHECKED BY: KCK

CHECKED BY: KCK

DATE: 06/27/07

DRAWN BY: DAF

FILE NAME: east grand dk3.dgn

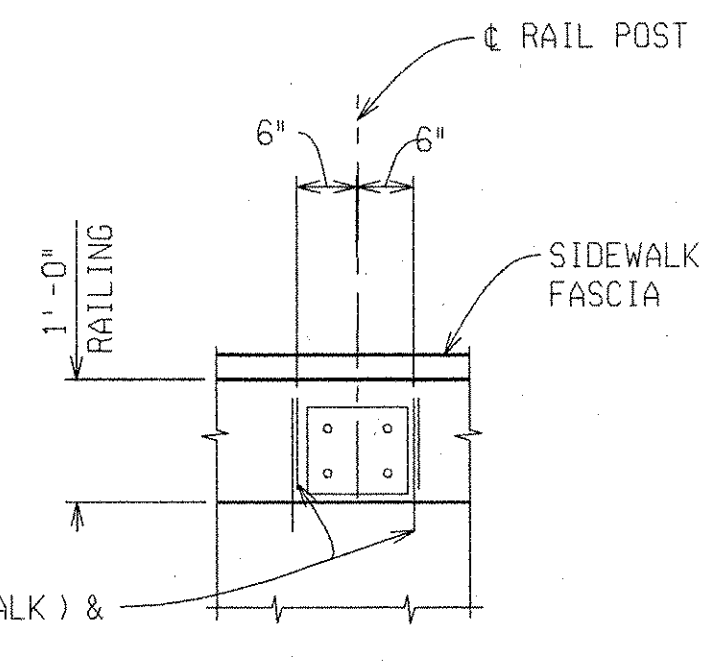
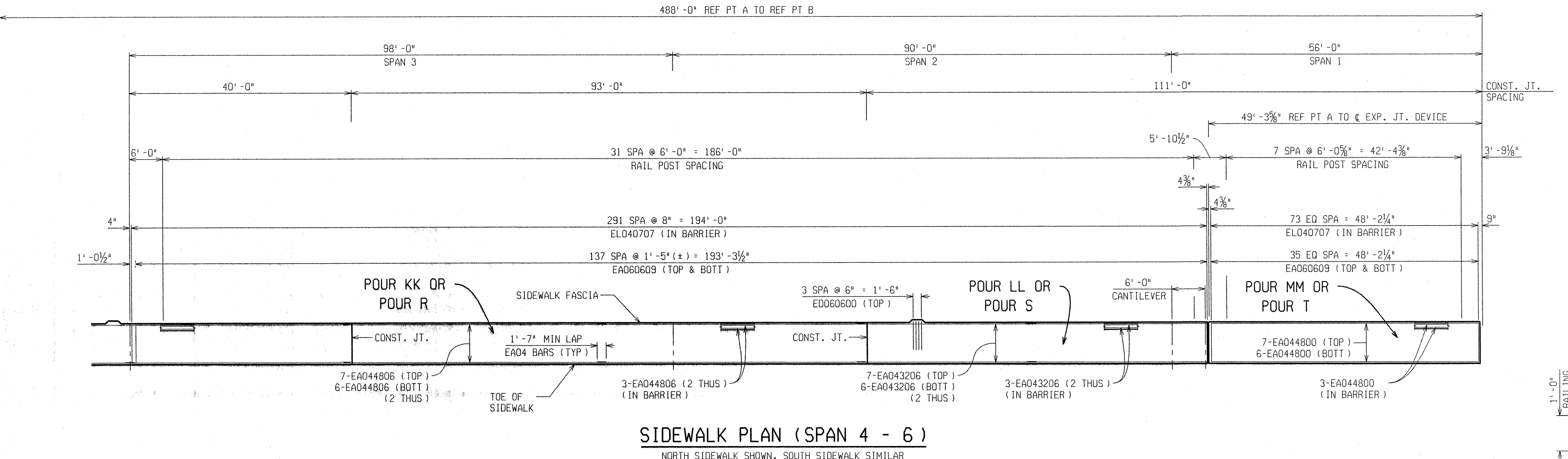
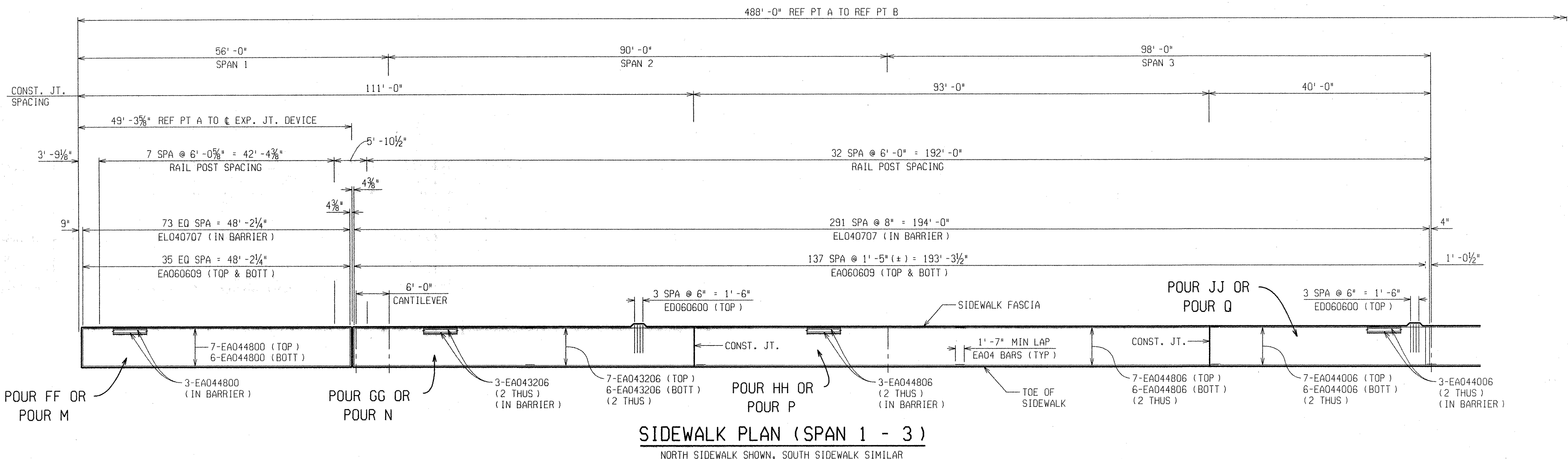

REVISIONS	DESCRIPTION	DATE	BY



EAST GRAND BLVD OVER
DETROIT CONNECTING RAILROAD

MDOT JOB NO. 86173A | STRUCTURE NO. R01 of 82-22-54

SUPERSTRUCTURE DETAILS

DATE: 04/16/08
DLZ JOB NO. 0642-6090-00
SHEET NO. 26 OF 60

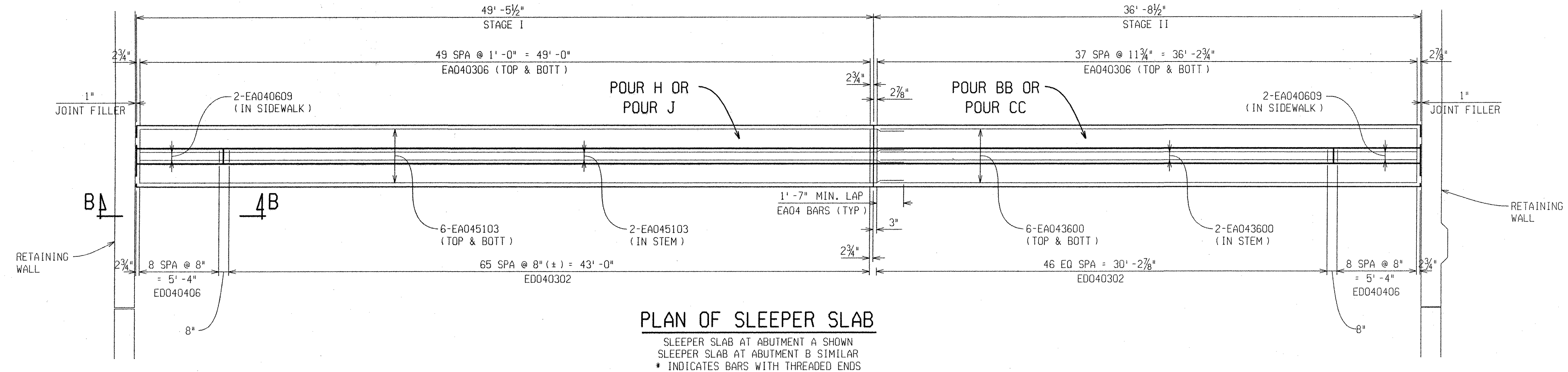

PLAN OF SLEEPER SLAB

SLEEPER SLAB AT ABUTMENT A SHOWN
 SLEEPER SLAB AT ABUTMENT B SIMILAR
 * INDICATES BARS WITH THREADED ENDS

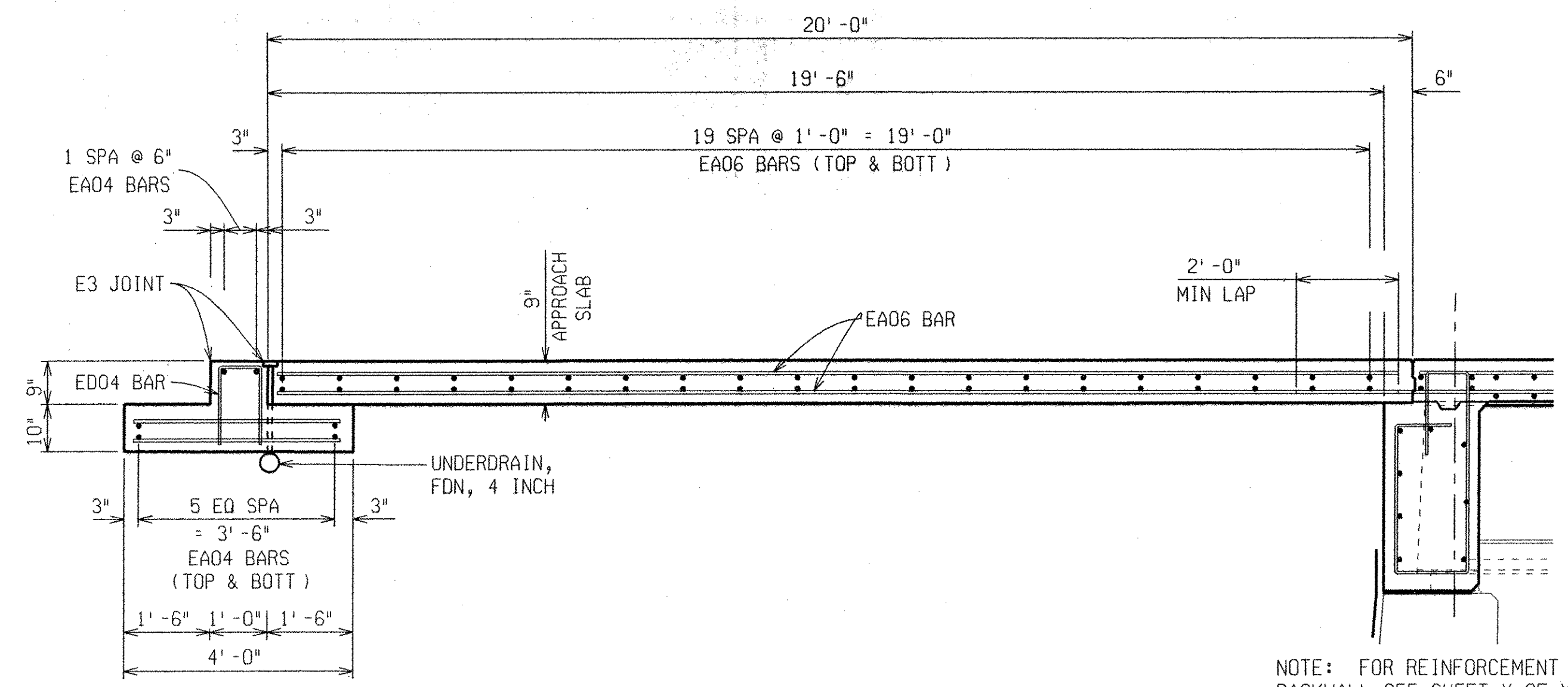

APPROACH SLAB SECTION

NOTE: FOR REINFORCEMENT IN THE BACKWALL SEE SHEET X OF X

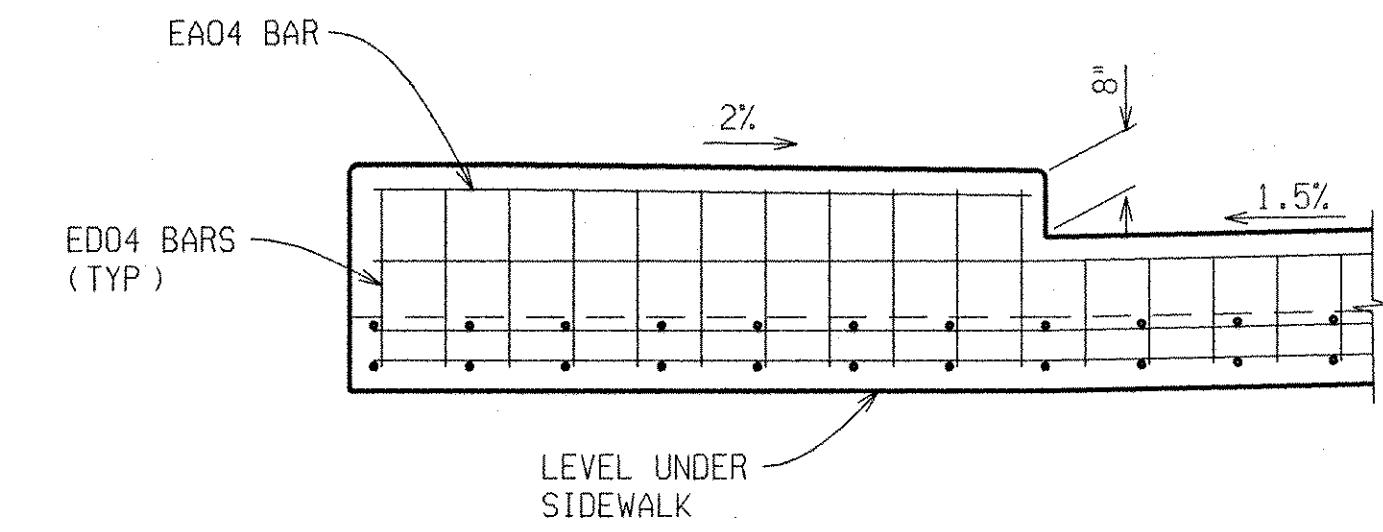

SECTION B-B

REVISIONS	DESCRIPTION	DATE	BY



EAST GRAND BLVD OVER
 DETROIT CONNECTING RAILROAD
 MDOT JOB NO. 86173A STRUCTURE NO. R01 of 82-22-54

SUPERSTRUCTURE DETAILS

DATE: 04/16/08
 DLZ JOB NO. 0642-6090-00
 SHEET NO. 27 OF 60

DATE: 07/06/07 CORRECTED BY: KCK CHECKED BY: KCK DRAWN BY: DW FILE NAME: east_grand_ak4.dgn

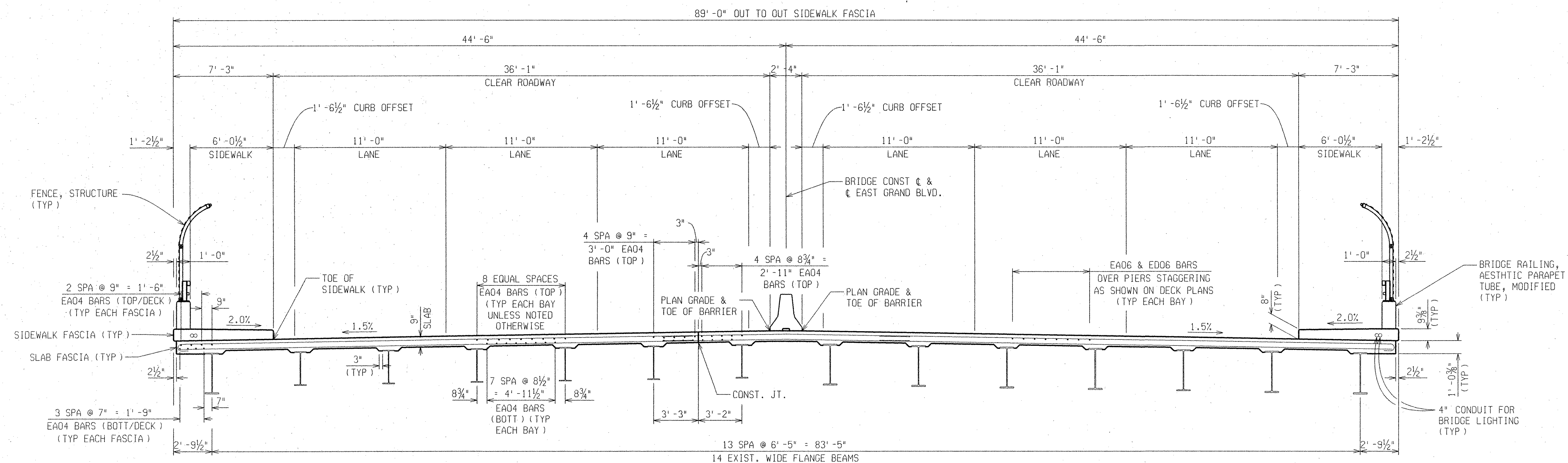

TYPICAL DECK SECTION
(LOOKING UPSTATION)

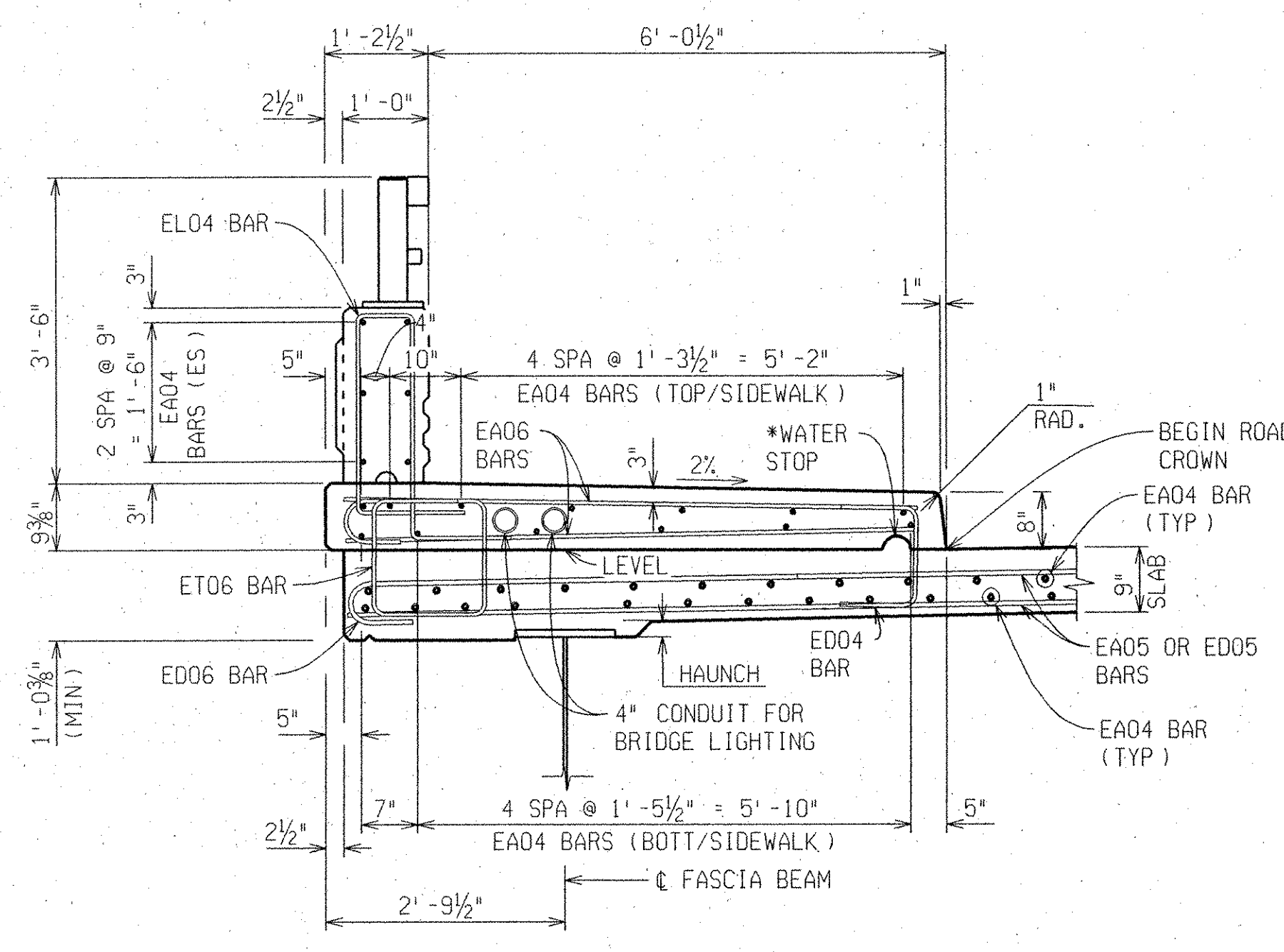

TYPICAL SIDEWALK SECTION
* 2" HIGH x 4" LONG (±), FORMING NOT REQUIRED

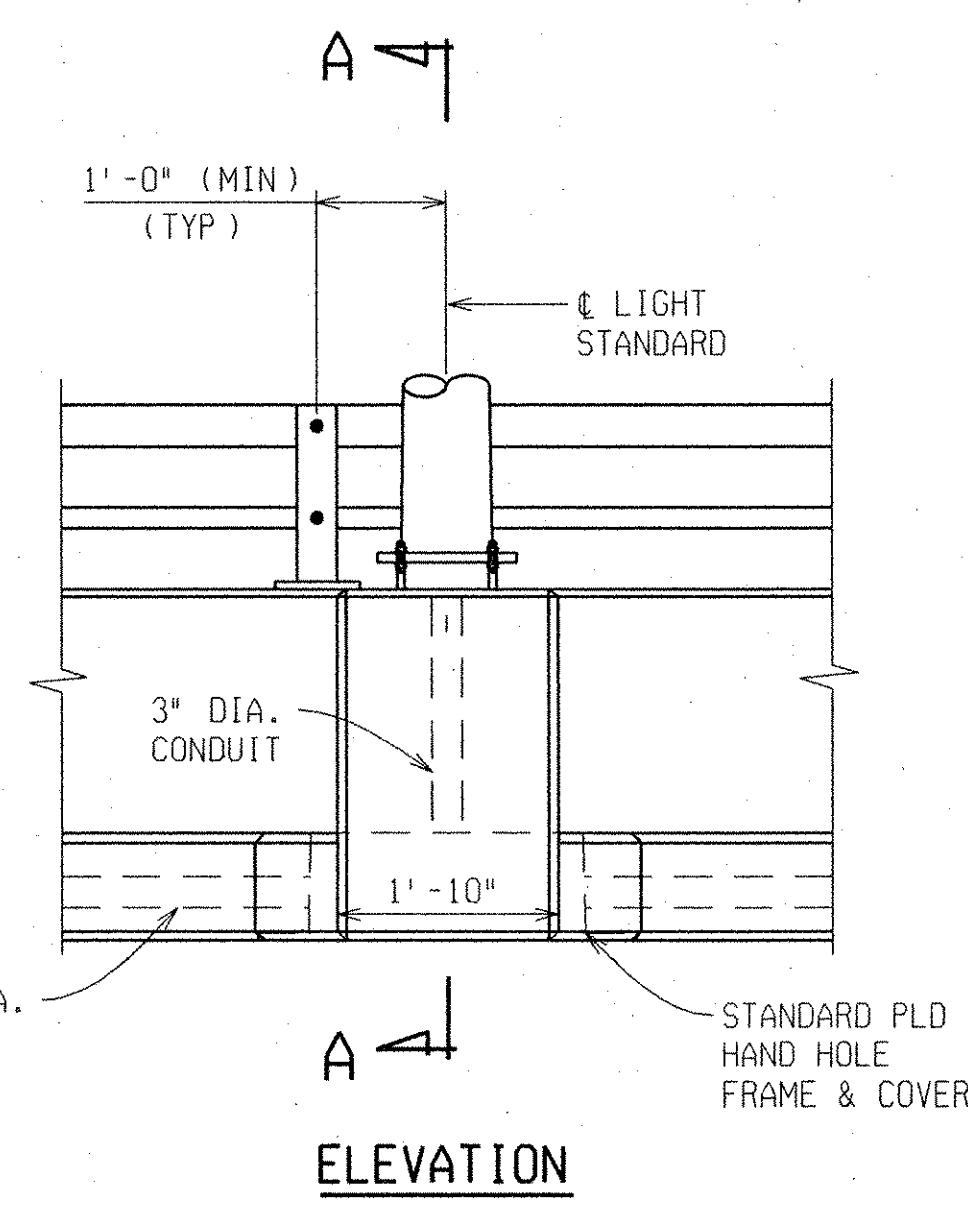

ELEVATION

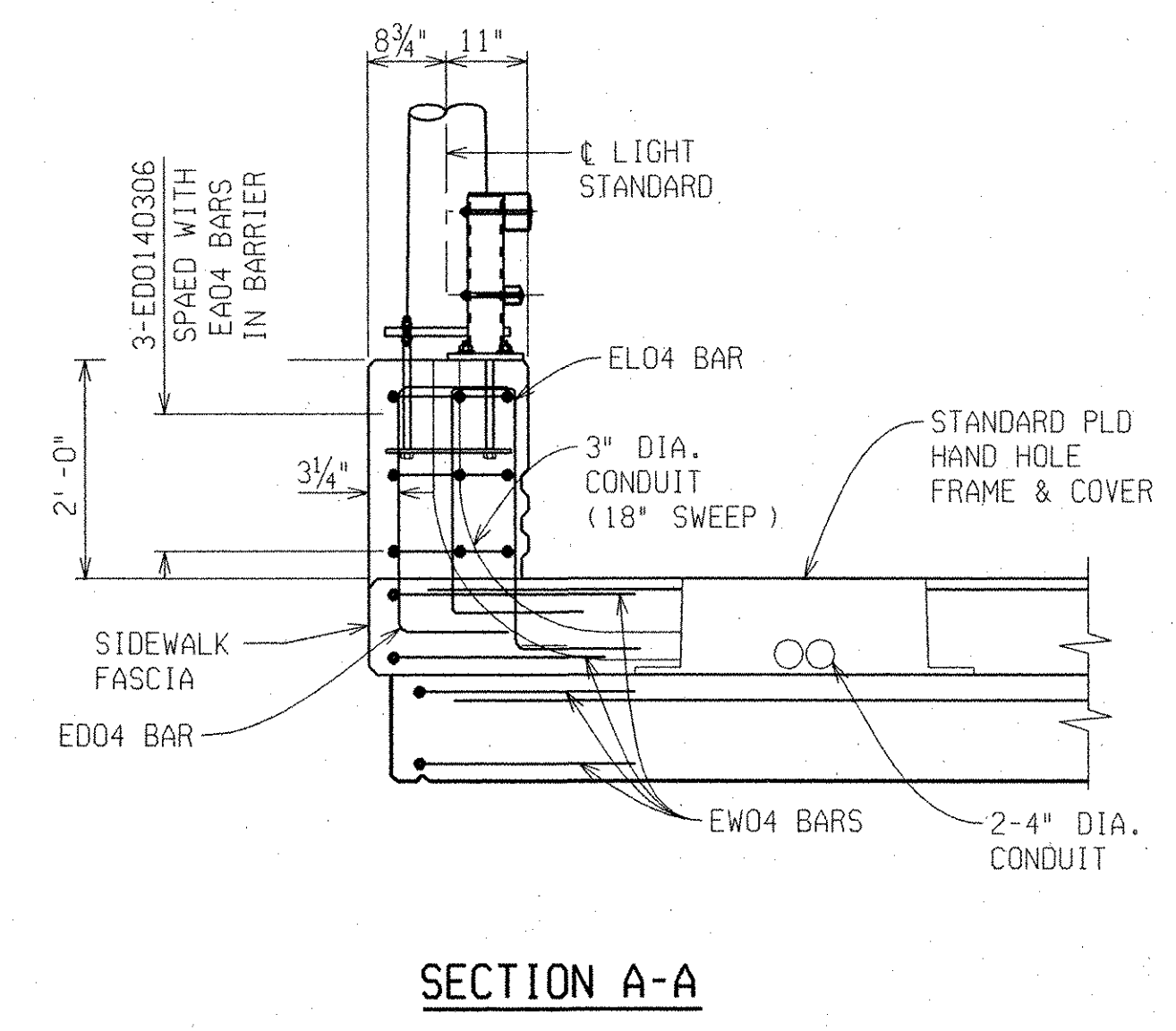

SECTION A-A

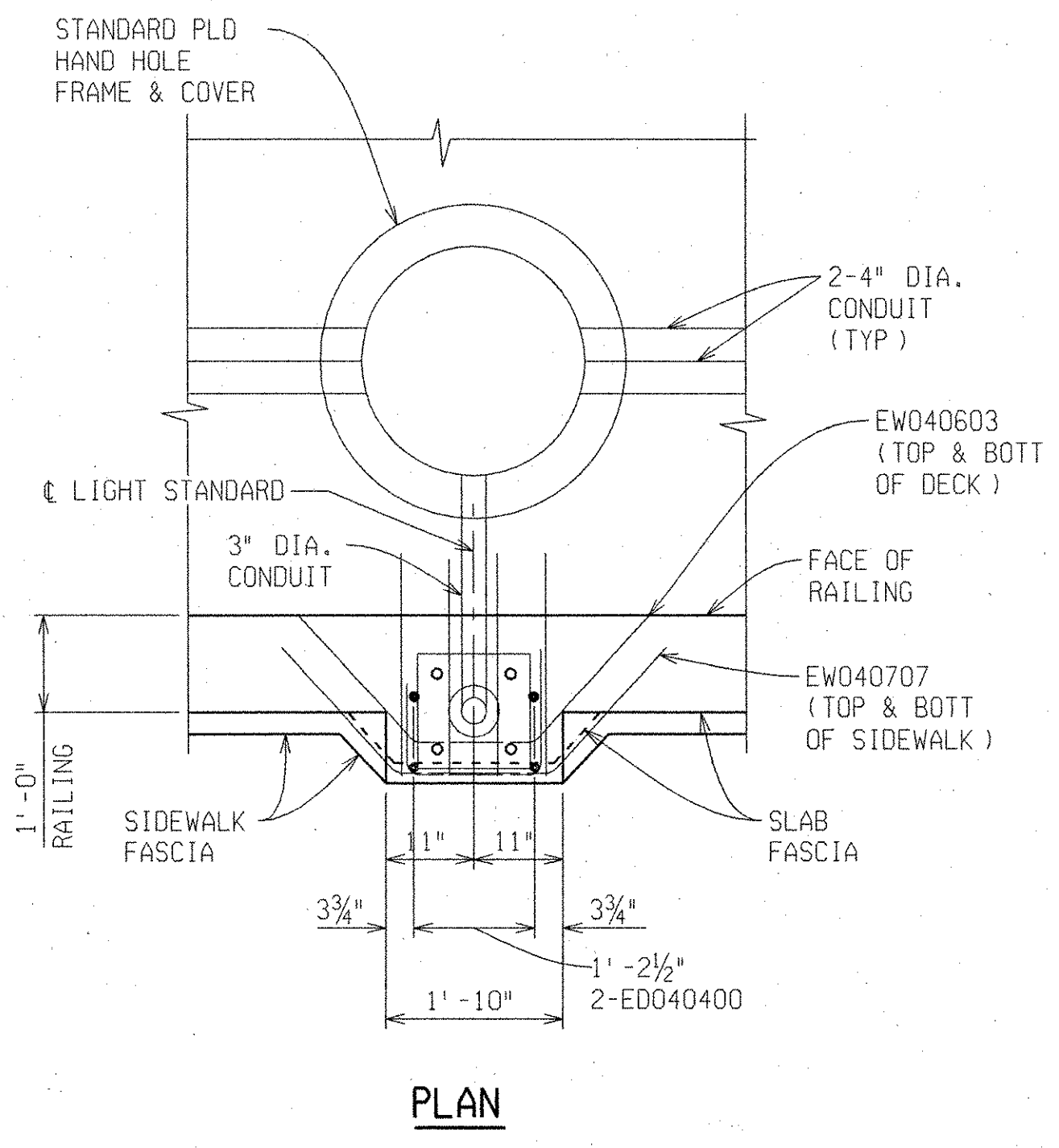

PLAN

LIGHT STANDARD DETAIL

(TYP 6 LIGHT STANDARDS)
THE LIGHT STANDARD ANCHOR BOLT ASSEMBLIES ARE INCLUDED IN THE PAYMENT FOR "Bridge Railing, Aesthetic Parapet Tube, Modified".

REVISIONS	DESCRIPTION	DATE	BY

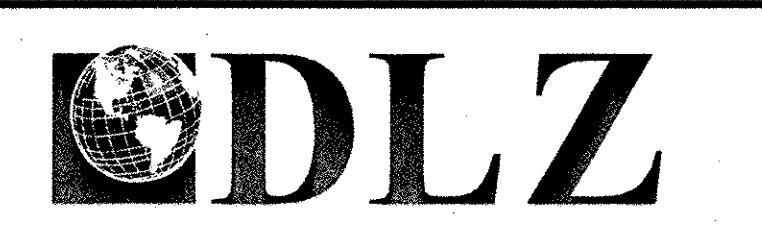

EAST GRAND BLVD OVER
DETROIT CONNECTING RAILROAD

MDOT JOB NO. 86173A STRUCTURE NO. R01 of 82-22-54

SUPERSTRUCTURE DETAILS

DATE: 04/16/08
DLZ JOB NO. 0642-6090-00
SHEET NO. 28 OF 60

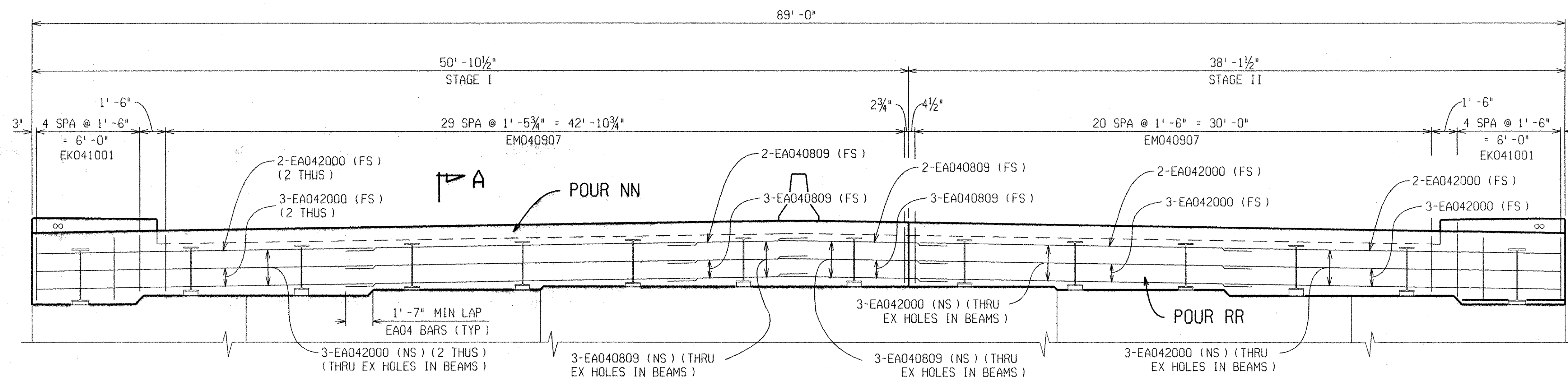

BACKWALL ELEVATION - ABUTMENT A

* INDICATES BARS WITH THREADED END

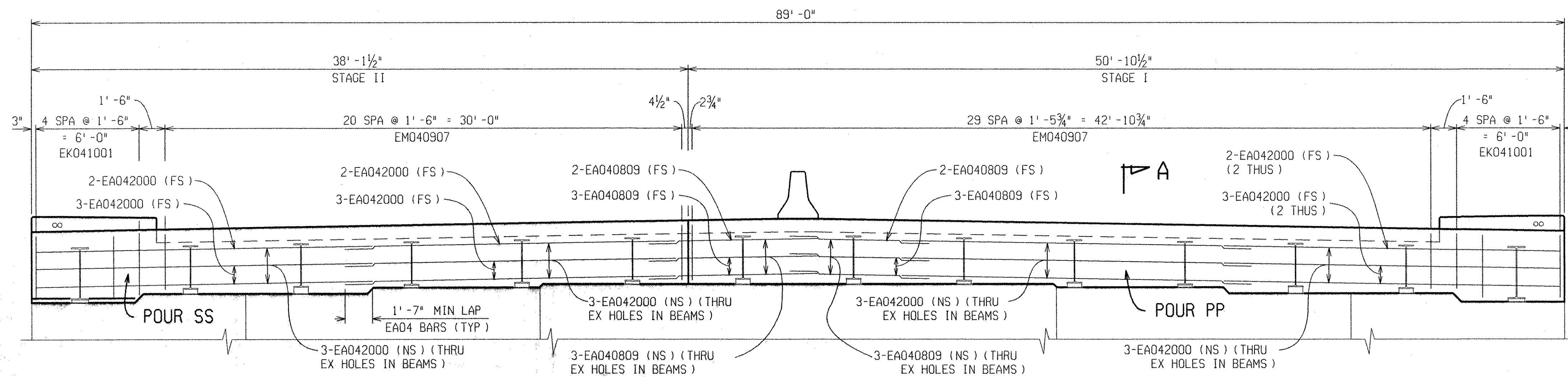

BACKWALL ELEVATION - ABUTMENT B

* INDICATES BARS WITH THREADED END

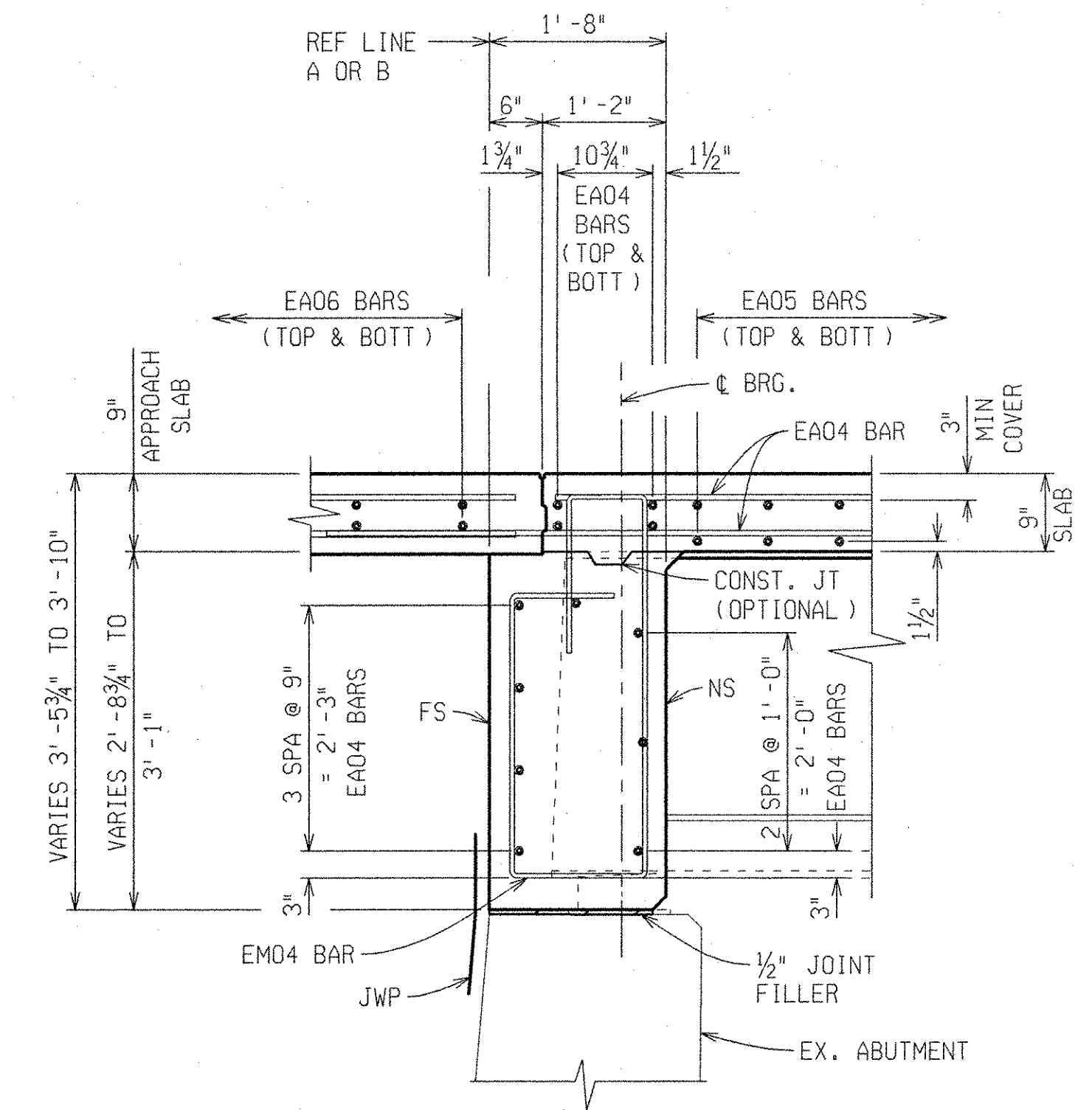

SECTION A-A

NOTE: FOR REINFORCEMENT IN THE APPROACH SLAB SEE SHEET 23 AND 24

REVISIONS	DESCRIPTION	DATE	BY



EAST GRAND BLVD OVER
DETROIT CONNECTING RAILROAD
MDOT JOB NO. 86173A STRUCTURE NO. R01 of 82-22-54

SUPERSTRUCTURE DETAILS

DATE: 04/16/08
DLZ JOB NO. 0642-6090-00
SHEET NO. 29 OF 60

DATE: 07/03/07 CORRECTED BY: KCK CHECKED BY: KCK DATE: 07/02/07 DRAWN BY: DW FILE NAME: east_grand_ek6.dgn

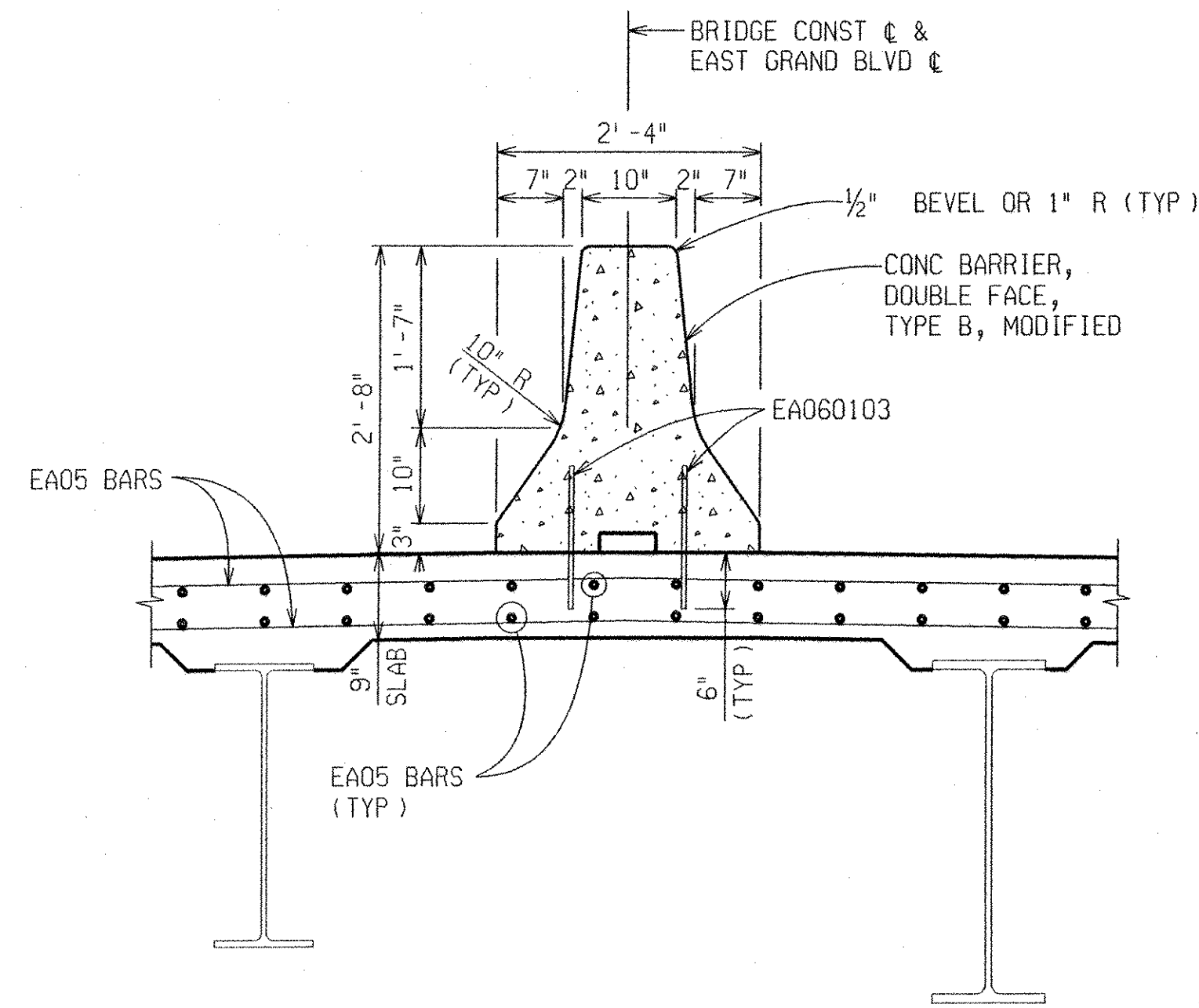

TYPICAL CONCRETE BARRIER SECTION

* FOR DOWEL SPACING SEE PLAN OF SLAB. COST OF DOWELS SHALL BE INCLUDED IN THE COST OF "Conc Barrier, Double Face, Type B, Modified".

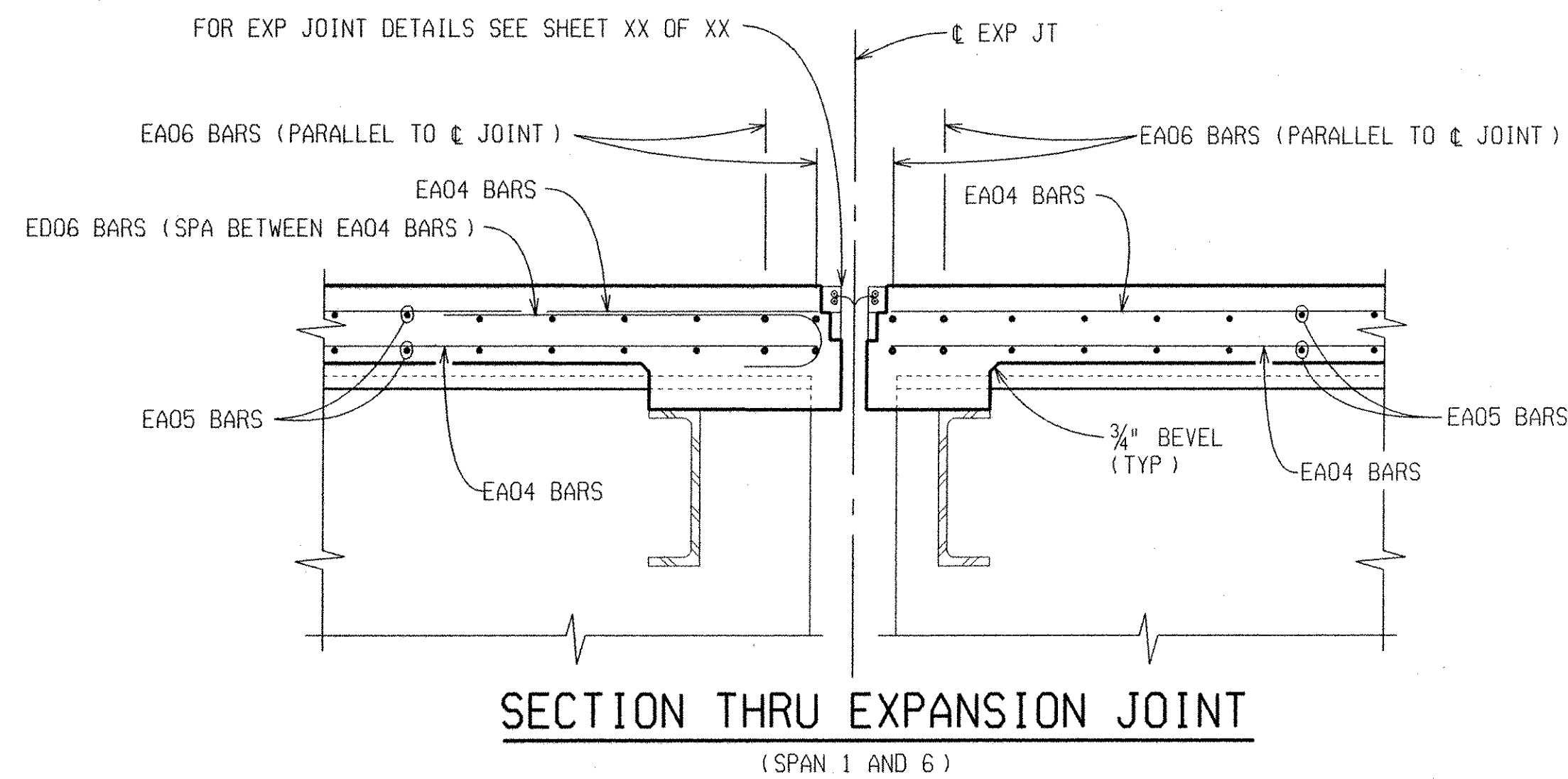

SECTION THRU EXPANSION JOINT

(SPAN 1 AND 6)

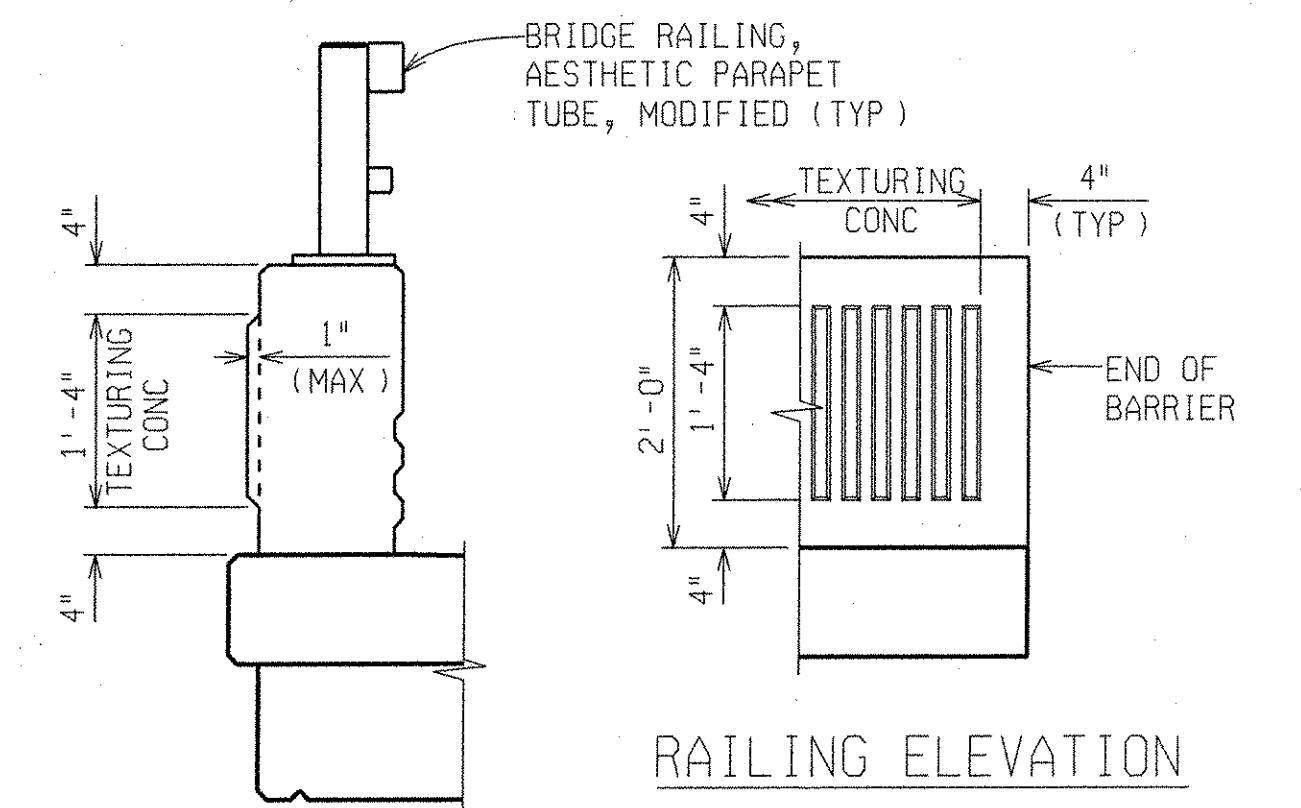

RAILING SECTION

RAILING RUSTICATION DETAILS

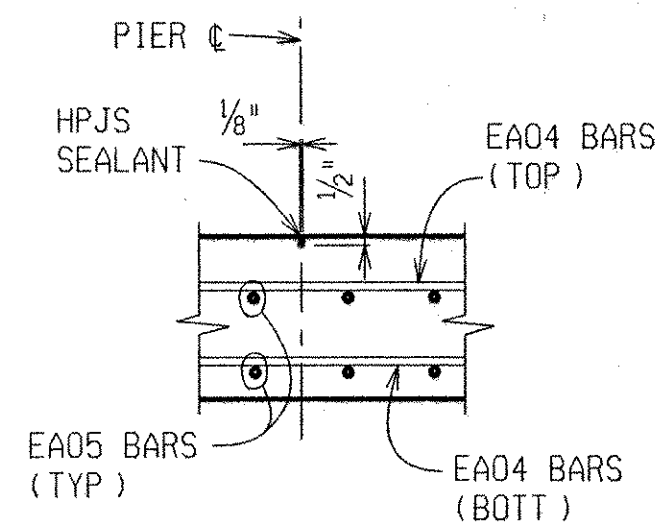

SECTION THRU CONTROL JOINT

PROVIDE JOINT OVER EACH PIER ALONG PIER

MISCELLANEOUS QUANTITIES

350	Ft	Joint, Expansion, E3
1551	Cyd	Superstructure Conc
1	LS	Superstructure Conc, Form, Finish, and Cure (R01 of 82-22-54)
976	Ft	Bridge Railing, Aesthtec Parapet Tube, Modified
529	Ft	Conc Barrier, Double Face, Type B, Modified
976	Sft	Fence, Structure

SUPERSTRUCTURE CONC, QUANTITIES

POUR	CYD	POUR	CYD
A	68.9	W	64.9
B	68.9	X	64.9
C	86.7	Y	98.0
D	86.7	Z	98.0
E	130.9	AA	84.3
F	130.9	BB	5.6
G	112.6	CC	5.6
H	7.5	DD	20.4
J	7.5	EE	20.4
K	27.5	FF	9.5
L	27.5	GG	11.9
M	9.5	HH	18.0
N	11.9	JJ	15.5
P	18.0	KK	18.0
Q	15.5	LL	11.9
R	18.0	MM	9.5
S	11.9	NN	11.6
T	9.5	PP	11.6
U	51.5	RR	8.8
V	51.5	SS	8.8
		TOTAL	1550.1

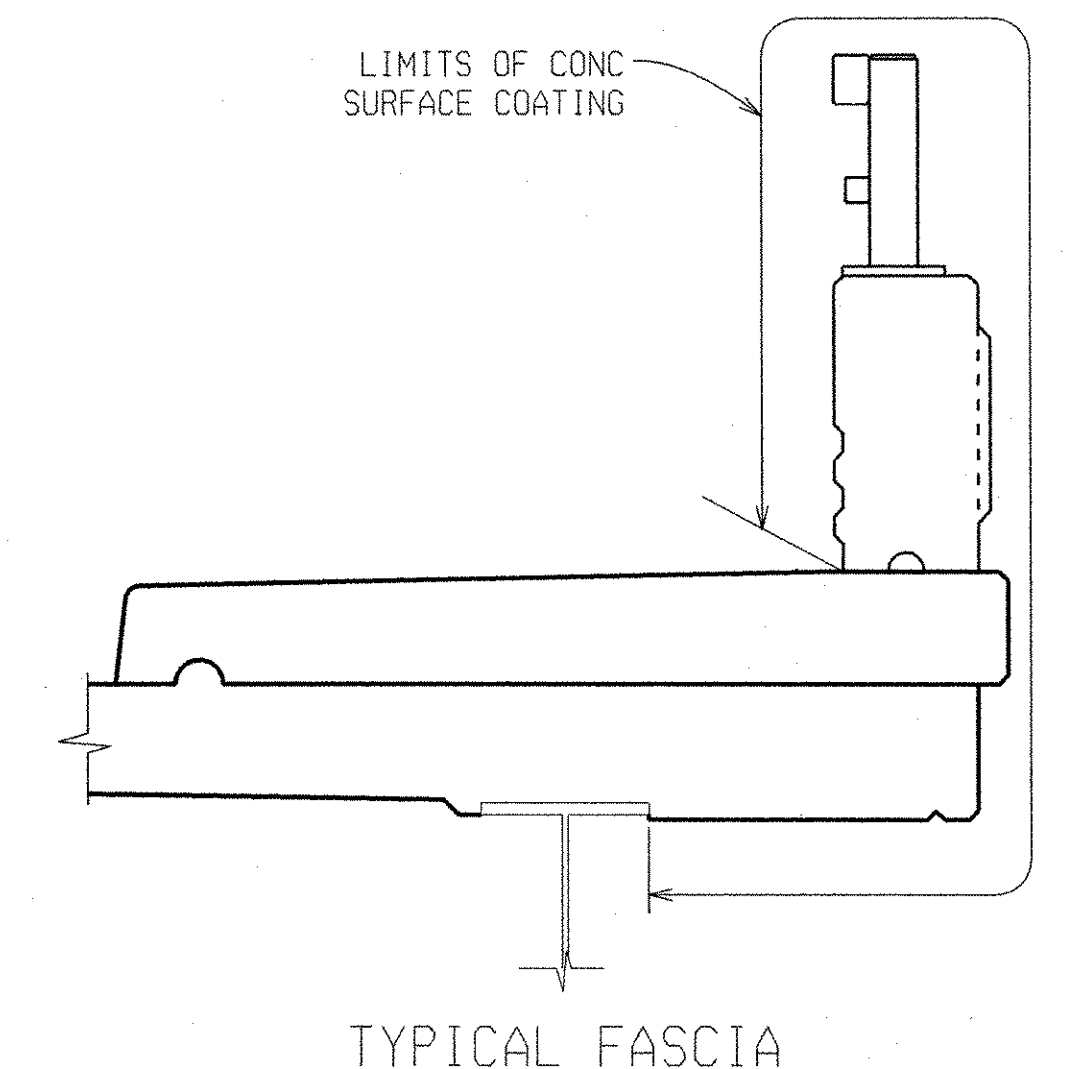

TYPICAL FASCIA

CONCRETE SURFACE COATING

NOTES:

JWP DENOTES JOINT WATERPROOFING.

A RUBBED SURFACE FINISH ON THE VERTICAL AND TOP CONCRETE SURFACES OF THE PARAPET RAILING IS REQUIRED ON THIS STRUCTURE.

FOR DETAILS OF LIGHT STANDARD ANCHOR BOLT ASSEMBLIES, SEE STANDARD PLAN B-103-SERIES.

"EDGE" OR "GROOVE" DENOTES EDGING OR GROOVING WITH AN APPROVED TOOL.

DECK POURS ARE TO BE MADE IN THE FOLLOWING SEQUENCE: SOUTH PORTION-POURS NN AND PP SHALL BE MADE FIRST IN ANY ORDER, THEN POURS A AND B SHALL BE MADE IN ANY ORDER, POURS C AND D SHALL THEN BE MADE IN ANY ORDER, THEN POURS E AND F SHALL BE MADE IN ANY ORDER, POUR G SHALL THEN BE MADE, THEN POURS H AND J SHALL BE MADE IN ANY ORDER, POURS K AND L SHALL THEN BE MADE IN ANY ORDER AND POURS M THROUGH T SHALL BE MADE LAST IN ANY ORDER. NORTH PORTION-POURS RR AND SS SHALL BE MADE FIRST IN ANY ORDER, THEN POURS U AND V SHALL BE MADE IN ANY ORDER, POUR W AND X SHALL THEN BE MADE IN ANY ORDER, THEN POURS Y AND Z SHALL BE MADE IN ANY ORDER, POUR AA SHALL THEN BE MADE, THEN POURS BB AND CC SHALL BE MADE IN ANY ORDER, POURS DD AND EE SHALL THEN BE MADE IN ANY ORDER AND POURS FF THROUGH MM SHALL BE MADE LAST IN ANY ORDER.

NO PORTION OF THE DECK FORMWORK SHALL ENCROACH ON THE EXISTING UNDERCLEARANCE.

LOW TEMPERATURE PROTECTION OF CONCRETE SHALL BE APPLIED ACCORDING TO SECTION 706.03J OF THE STANDARD SPECIFICATIONS FOR CONSTRUCTION. LOW TEMPERATURE PROTECTION OF CONCRETE WILL NOT BE PAID FOR SEPARATELY, BUT WILL BE INCLUDED IN THE BID ITEM "Superstructure Conc".

THE LIGHT STANDARD ANCHOR BOLT ASSEMBLIES ARE INCLUDED IN THE PAYMENT FOR "Bridge Railing, Aesthetic Parapet Tube, Modified".

THE CONTRACTOR MAY USE METAL STAY IN PLACE FORMS. IF USED, THE CONTRACTOR MAY OMIT THE POLYSTYRENE FROM THE CORRUGATIONS AND FILL THE FORMS FULL DEPTH. THE EXTRA CONCRETE REQUIRED TO FILL THE CORRUGATIONS WILL NOT BE PAID FOR.

THE CONTRACTOR IS TO PROVIDE A SAWED JOINT 1/2" DEEP BY 1/8" WIDE (MINIMUM) IN THE TOP OF SLAB AT TRANSVERSE CONSTRUCTION JOINTS AND AT LONGITUDINAL CONSTRUCTION JOINTS. THE JOINT IS TO BE SAWED WITHIN 4 HOURS OF REMOVING THE CURING AND IS TO BE FILLED WITH HOT-POURED JOINT SEALANT OR COLD-APPLIED JOINT SEALANT, SINGLE COMPONENT TYPE. (INCLUDED IN THE BID ITEM "Superstructure, Conc, Form, Finish and Cure (R01 of 82-22-54)")

REVISIONS	DESCRIPTION	DATE	BY



EAST GRAND BLVD OVER
DETROIT CONNECTING RAILROAD

MDOT JOB NO. 86173A STRUCTURE NO. R01 of 82-22-54

SUPERSTRUCTURE DETAILS

DATE: 04/16/08
DLZ JOB NO. 0642-6090-00
SHEET NO. 30 OF 60

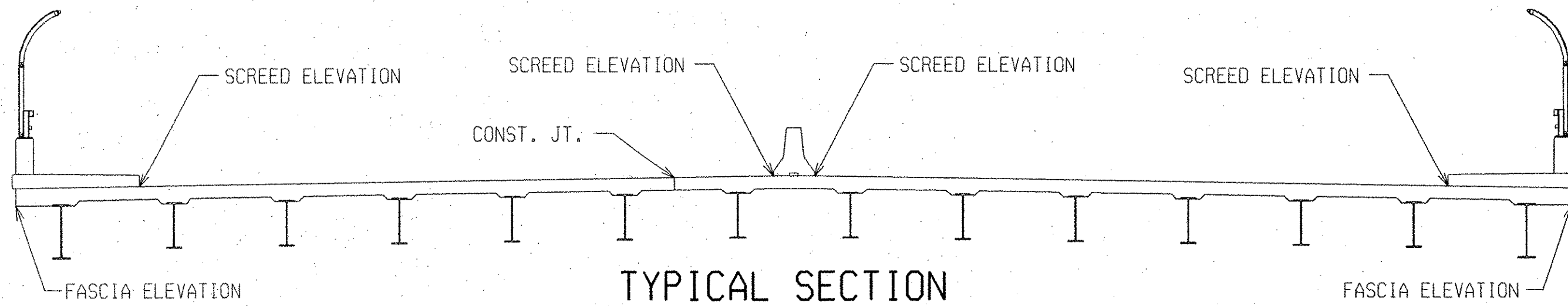
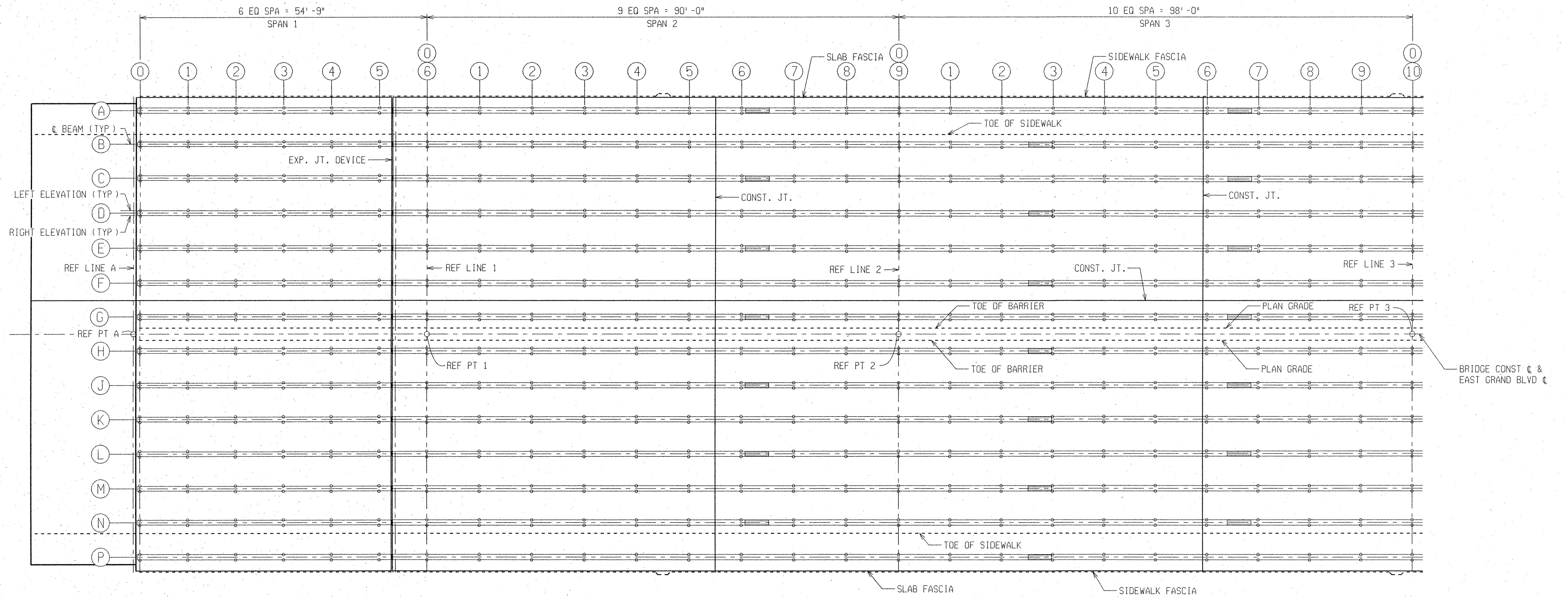

TYPICAL SECTION

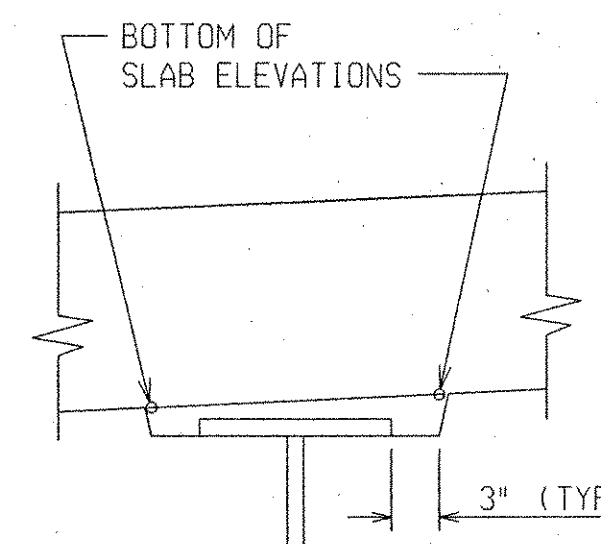

TYPICAL SECTION @ BEAM

NOTES:

BOTTOM OF SLAB ELEVATIONS ARE AT RIGHT ANGLES TO THE BEAM CENTERLINE AND ARE BASED ON THE CONDITION THAT THE BEAMS AND DIAPHRAGMS ARE COMPLETELY ERECTED WITH NO OTHER LOADS APPLIED. NO TEMPORARY SUPPORTS ARE ALLOWED AT THIS TIME. THESE ELEVATIONS INCLUDE ALLOWANCE FOR VERTICAL CURVE AND DEFLECTION DUE TO FORMS, STEEL REINFORCEMENT, CONCRETE SLAB, AND BARRIERS.

SCREED ELEVATIONS ARE BASED ON THE CONDITION THAT NO SLAB CONCRETE HAS BEEN CAST AND THAT FORMWORK, SHEAR DEVELOPERS AND STEEL REINFORCEMENT ARE IN PLACE.

SCREEDS AFFECTED BY LOADS IN OTHER SPANS ARE TO BE SET TO THE ELEVATIONS SHOWN BEFORE CASTING ANY CONCRETE. CONCRETE IN THE SUSPENDED SPANS IS TO BE CAST BEFORE CONCRETE ANCHOR SPANS.

TRANSVERSE FINISHING SHALL BE PARALLEL TO REFERENCE LINES.

SCREED RAILS FOR FINISHING OF STRUCTURAL CONCRETE SHALL BE LOCATED OVER THE FASCIA BEAMS.

REVISIONS	DESCRIPTION	DATE	BY



EAST GRAND BLVD OVER
DETROIT CONNECTING RAILROAD
MDOT JOB NO. 86173A STRUCTURE NO. R01 of 82-22-54

SLAB & SCREED DETAILS

DATE: 04/16/08
DLZ JOB NO. 0642-6090-00
SHEET NO. 31 OF 60

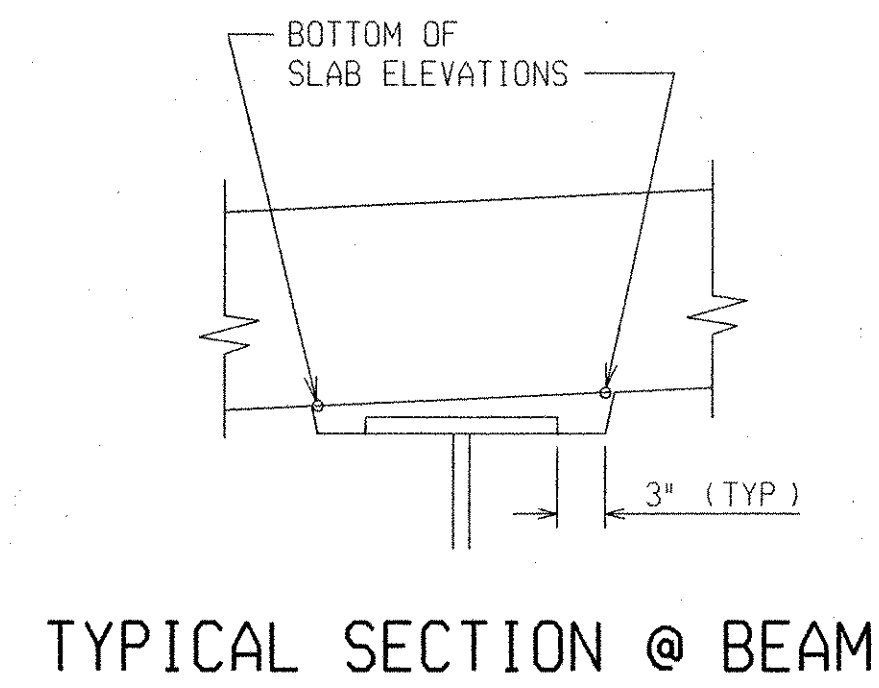
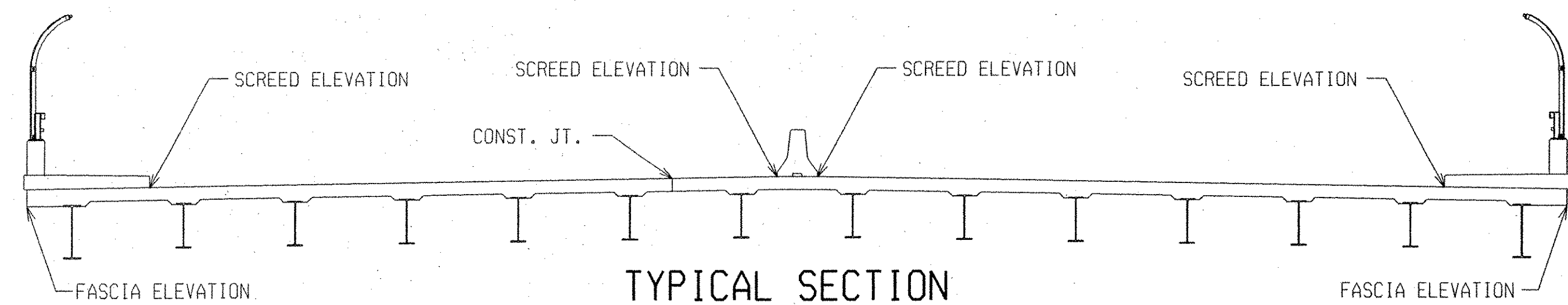
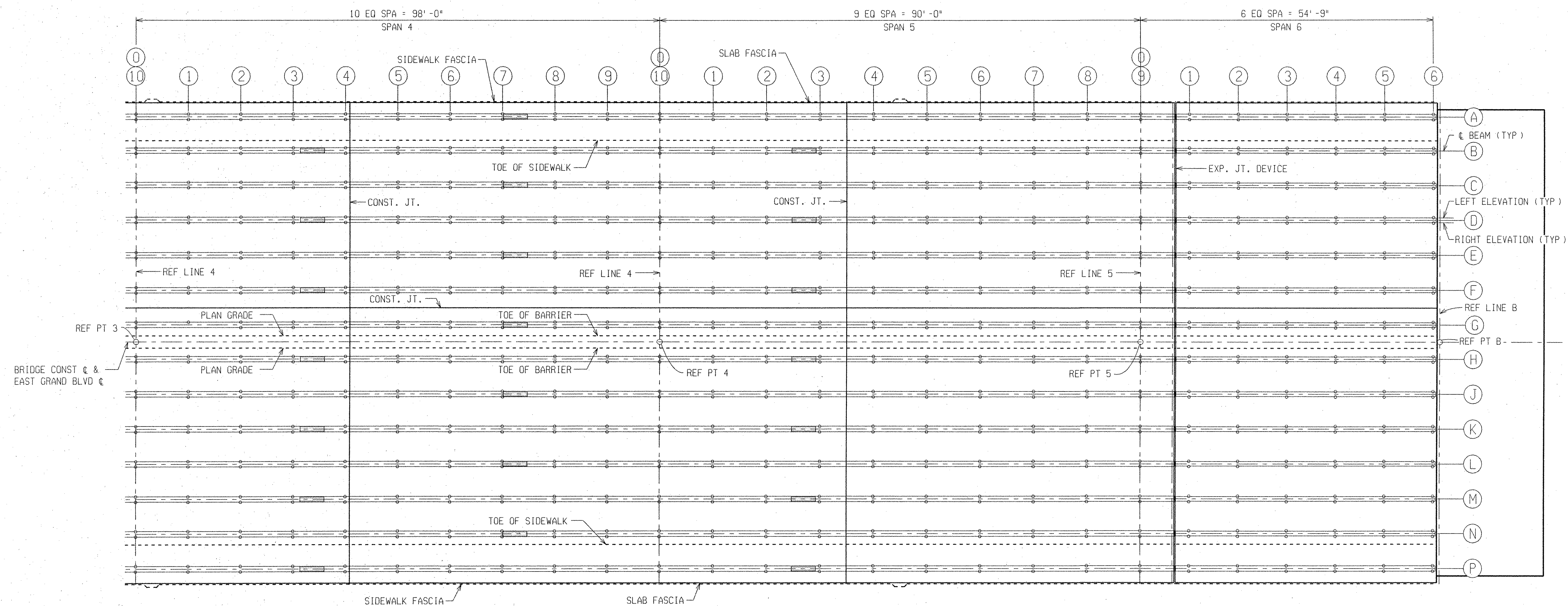

NOTES:

BOTTOM OF SLAB ELEVATIONS ARE AT RIGHT ANGLES TO THE BEAM CENTERLINE AND ARE BASED ON THE CONDITION THAT THE BEAMS AND DIAPHRAGMS ARE COMPLETELY ERECTED WITH NO OTHER LOADS APPLIED. NO TEMPORARY SUPPORTS ARE ALLOWED AT THIS TIME. THESE ELEVATIONS INCLUDE ALLOWANCE FOR VERTICAL CURVE AND DEFLECTION DUE TO FORMS, STEEL REINFORCEMENT, CONCRETE SLAB, AND BARRIERS.

SCREED ELEVATIONS ARE BASED ON THE CONDITION THAT NO SLAB CONCRETE HAS BEEN CAST AND THAT FORMWORK, SHEAR DEVELOPERS AND STEEL REINFORCEMENT ARE IN PLACE.

SCREEDS AFFECTED BY LOADS IN OTHER SPANS ARE TO BE SET TO THE ELEVATIONS SHOWN BEFORE CASTING ANY CONCRETE. CONCRETE IN THE SUSPENDED SPANS IS TO BE CAST BEFORE CONCRETE ANCHOR SPANS.

TRANSVERSE FINISHING SHALL BE PARALLEL TO REFERENCE LINES.

SCREED RAILS FOR FINISHING OF STRUCTURAL CONCRETE SHALL BE LOCATED OVER THE FASCIA BEAMS.

REVISIONS	DESCRIPTION	DATE	BY



EAST GRAND BLVD OVER
DETROIT CONNECTING RAILROAD

MDOT JOB NO. 86173A STRUCTURE NO. R01 of 82-22-54

SLAB & SCREED DETAILS

DATE: 04/16/08

DLZ JOB NO. 0642-6090-00

SHEET NO. 32 OF 60

SCREED ELEVATIONS

	0	1	2	3	4	5	6	7	8	9	10	11	12	13	14		0	1	2	3	4	5	6	7	8	9	10	11	12	13	14			
EASTBOUND SIDEWALK	170.79	171.03	171.27	171.52	171.76	172.00	172.24	172.48	172.73	172.97	173.21	173.65	174.09	174.54	174.96	175.36	175.73	176.07	176.38	176.66	176.84	177.00	177.16	177.29	177.41	177.52	177.61	177.69	177.76	177.81	177.84	177.86	177.87	177.86
CONST JT	171.25	171.50	171.74	171.98	172.22	172.46	172.71	172.95	173.19	173.43	173.67	174.12	174.56	175.00	175.43	175.83	176.19	176.53	176.84	177.12	177.30	177.47	177.62	177.75	177.88	177.98	178.08	178.15	178.22	178.27	178.30	178.33	178.33	178.32
PLAN GRADE	170.58	170.85	171.11	171.37	171.62	171.86	172.10	172.33	172.55	172.76	173.00	173.46	173.93	174.40	174.84	175.23	175.58	175.90	176.19	176.45	177.38	177.55	177.71	177.86	177.99	178.10	178.20	178.31	178.36	178.40	178.42	178.42	178.42	178.40
WESTBOUND SIDEWALK	170.79	171.03	171.27	171.52	171.76	172.00	172.24	172.48	172.73	172.97	173.21	173.65	174.09	174.54	174.96	175.36	175.73	176.07	176.38	176.66	176.84	177.00	177.16	177.29	177.41	177.52	177.61	177.69	177.76	177.81	177.84	177.86	177.87	177.86

	14	13	12	11	10	9	8	7	6	5	4	3	2	1	0		0	1	2	3	4	5	6	7	8	9	10		11	12	13	14				
EASTBOUND SIDEWALK	177.86	177.84	177.80	177.75	177.69	177.61	177.51	177.41	177.28	177.15	177.00	176.83	176.65	176.46	176.25	175.92	175.57	175.19	174.78	174.34	173.87	173.38	172.88	172.38	172.11	171.84	171.57	171.30	171.03	170.75	170.48	170.21	169.94	169.67		
CONST JT	178.32	178.30	178.27	178.22	178.15	178.07	177.98	177.87	177.75	177.61	177.46	177.29	177.11	176.92	176.71	176.39	176.03	175.65	175.24	174.80	174.33	173.84	173.34	172.85	172.57	172.30	172.03	171.76	171.49	171.22	170.95	170.67	170.40	170.13		
PLAN GRADE	178.40	178.39	178.36	178.33	178.28	178.21	178.09	177.99	177.87	177.72	177.56	177.39	177.20	177.00	176.79	175.74	175.41	175.05	174.65	174.21	173.73	173.21	172.69	172.17	171.93	171.68	171.42	171.16	170.89	170.61	170.33	170.04	169.73	169.46		
WESTBOUND SIDEWALK	177.86	177.84	177.80	177.75	177.69	177.61	177.51	177.41	177.28	177.15	177.00	176.83	176.65	176.46	176.25	175.92	175.57	175.19	174.78	174.34	173.87	173.38	172.88	172.38	172.11	171.84	171.57	171.30	171.03	170.75	170.48	170.21	169.94	169.67		

BOTTOM OF SLAB ELEVATIONS

	0	1	2	3	4	5	6	7	8	9	10	11	12	13	14		0	1	2	3	4	5	6	7	8	9	10	11	12	13	14				
A FASCIA	168.94	169.21	169.47	169.73	169.98	170.22	170.46	170.69	170.91	171.12	171.36	171.82	172.29	172.76	173.20	173.59	173.94	174.26	174.55	174.81	174.99	175.16	175.32	175.47	175.60	175.71	175.81	175.92	176.01	176.03	176.03	176.03	176.01		
B RIGHT	169.24	169.50	169.77	170.02	170.27	170.52	170.77	171.01	171.24	171.46	171.66	172.12	172.59	173.05	173.49	173.89	174.24	174.55	174.84	175.11	175.29	175.46	175.62	175.76	175.89	176.01	176.10	176.12	176.26	176.30	176.32	176.32	176.31		
C LEFT	169.31	169.58	169.84	170.10	170.35	170.59	170.83	171.06	171.28	171.48	171.73	172.19	172.66	173.13	173.56	173.96	174.31	174.63	174.91	175.18	175.36	175.53	175.69	175.84	175.97	176.08	176.17	176.28	176.34	176.37	176.39	176.40	176.39	176.38	
D RIGHT	169.33	169.60	169.86	170.12	170.37	170.61	170.85	171.08	171.30	171.51	171.75	172.21	172.68	173.15	173.59	173.98	174.33	174.65	174.94	175.20	175.38	175.55	175.71	175.86	175.99	176.10	176.20	176.31	176.36	176.40	176.42	176.42	176.40		
E LEFT	169.41	169.67	169.94	170.19	170.45	170.69	170.92	171.15	171.38	171.58	171.83	172.29	172.76	173.22	173.66	174.06	174.41	174.72	175.01	175.28	175.46	175.63	175.79	175.93	176.06	176.18	176.27	176.38	176.43	176.47	176.49	176.49	176.49	176.48	
F RIGHT	169.43	169.69	169.96	170.22	170.47	170.71	170.94	171.17	171.40	171.60	171.85	172.31	172.78	173.24	173.68	174.08	174.43	174.74	175.03	175.30	175.48	175.65	175.81	175.96	176.09	176.20	176.29	176.40	176.46	176.49	176.51	176.52	176.51	176.50	
G LEFT	169.50	169.77	170.03	170.29	170.54	170.78	171.02	171.25	171.47	171.68	171.92	172.38	172.85	173.32	173.76	174.15	174.50	174.82	175.11	175.37	175.55	175.72	175.88	176.03	176.16	176.27	176.37	176.48	176.53	176.57	176.59	176.59	176.59	176.57	176.57
H RIGHT	169.52	169.79	170.05	170.31	170.56	170.80	171.04	171.27	171.49	171.70	171.94	172.41	172.88	173.34	173.78	174.17	174.53	174.84	175.13	175.39	175.57	175.75	175.90	176.05	176.18	176.29	176.39	176.50	176.55	176.59	176.61	176.61	176.61	176.61	176.61
I LEFT	169.60	169.87	170.13	170.39	170.64	170.88	171.12	171.34	171.57	171.77	172.02	172.48	172.95	173.41	173.85	174.25	174.60	174.91	175.20	175.47	175.65	175.82	175.98	176.13	176.26	176.37	176.46	176.57	176.63	176.66	176.68	176.68	176.68	176.67	176.67
J RIGHT	169.62	169.89	170.15	170.41	170.66	170.90	171.14	171.36	171.59	171.79	172.04	172.50	172.97	173.44	173.88	174.27	174.62	174.94	175.22	175.49	175.67	175.84	176.00	176.15	176.28	176.39	176.49	176.59	176.65	176.69	176.70	176.71	176.71	176.69	176.69
K LEFT	169.69	169.96	170.23	170.48	170.73	170.98	171.21	171.44	171.67	171.87	172.11	172.58	173.05	173.51	173.95	174.34	174.70	175.01	175.30	175.56	175.74	175.92	176.07	176.22	176.35	176.46	176.56	176.67	176.72	176.76	176.78	176.80	176.81	176.80	176.79
L RIGHT	169.72	169.99	170.25	170.50	170.75	171.00	171.23	171.46	171.69	171.89	172.14	172.61	173.07	173.53	173.97	174.37	174.72	175.03	175.32	175.59	175.77	175.94	176.10	176.24	176.37	176.49	176.58	176.69	176.75	176.78	176.80	176.81	176.80	176.79	176.79
M LEFT	169.79	170.06	170.32	170.58	170.83	171.07	171.31	171.54	171.76	171.97	172.21	172.67	173.14	173.61	174.05	174.44	174.79	175.11	175.39	175.66	175.84	176.01	176.17	176.32	176.45	176.56	176.66	176.76	176.82	176.86	176.88	176.90	176.90	176.88	176.88
N RIGHT	169.81	170.08	170.34	170.60	170.85	171.09	171.33	171.56	171.78	171.99	172.23	172.69	173.16	173.63	174.07	174.46	174.81	175.13	175.42	175.68	175.86	176.03	176.19	176.34	176.47	176.58	176.68	176.79	176.84	176.88	176.90	176.90	176.88	176.88	176.88
O LEFT	169.81	170.08	170.34	170.60	170.85	171.09	171.33	171.56	171.78	171.99	172.23	172.69	173.16	173.63	174.07	174.46	174.81	175.13	175.42	175.68	175.86	176.03	176.19	176.34	176.47	176.58	176.68	176.79	176.84	176.88	176.90	176.90	176.88	176.88	176.88
P RIGHT	169.79	170.06	170.32	170.58	170.83	171.07	171.31	171.54	171.76	171.97	172.21	172.67	173.14	173.61	174.05	174.44	174.79	175.11	175.39	175.66	175.84	176.01	176.17	176.32	176.45	176.56	176.66	176.76	176.82	176.86	176.88	176.90	176.88	176.88	176.88
Q LEFT	169.72	169.99	170.25	170.50	170.75	171.00	171.23	171.46	171.69	171.89	172.14	172.61	173.07	173.53	173.97	174.37	174.72	175.03	175.32	175.59	175.77	175.94	176.10	176.24	176.37	176.49	176.58	176.69	176.75	176.78	176.80	176.81	176.80	176.79	176.79
R RIGHT	169.79	170.06	170.32	170.58	170.83	171.07	171.31	171.54	171.76	171.97	172.21	172.67	173.14	173.61	174.05	174.44	174.79	175.11	175.39	175.66	175.84	176.01	176.17	176.32	176.45	176.56	176.66	176.76	176.82	176.86	176.88	176.90	176.90	176.88	176.88
S LEFT	169.81	170.08	170.34	170.60	170.85	171.09	171.33	171.56	171.78	171.99	172.23	172.69	173.16	173.63	174.07	174.46	174.81	175.13	175.42	175.68	175.86	176.03	176.19	176.34	176.47	176.58	176.68	176.79	176.84	176.88	176.90	176.90	176.88	176.88	176.88
T RIGHT	169.81	170.08	170.34	170.60	170.85	171.09	171.33	171.56	171.78	171.99	172.23	172.69	173.16	173.63	174.07	174.46	174.81	175.13	175.42	175.68	175.86	176.03	176.19	176.34	176.47	176.58	176.68	176.79	176.84	176.88	176.90	176.90	176.88	176.88	176.88
U LEFT	169.81	170.08	170.34	170.60	170.85	171.09	171.33	171.56	171.78	171.99	172.23	172.69	173.16	173.63	174.07	174.46	174.81	175.13	175.42	175.68	175.86	176.03	176.19	176.34	176.47	176.58	176.68	176.79	176.84	176.88	176.90	176.90	176.88	176.88	176.88
V RIGHT	169.79	170.06	170.32	170.58	170.83	171.07	171.31	171.54	171.76	171.97	172.21	172.67	173																						

SUPERSTRUCTURE - STAGE I

BAR	DIMENSIONS								NO. REQ'D	TOTAL WT.
	a	b	c	d	e	f	g	h		
EA040306	3' - 6"								200	468
EA040609	6' - 9"								4	19
EA040809	8' - 9"								16	94
EA042000	20' - 0"								32	428
EA043206	32' - 6"								592	12853
EA044006	40' - 6"								296	8008
EA044800	48' - 0"								296	9491
EA044806	48' - 6"								592	19180
EA045103	51' - 3"								28	959
EA051800	18' - 0"								1380	25909
EA053703	37' - 3"								690	26808
EA060609	6' - 9"								696	7057
EA062200	22' - 0"								252	8328
EA063806	38' - 6"								240	13879
EA064100	41' - 0"								240	14780
EA065200	52' - 0"								80	6249
ED040211	0' - 10 3/4"	1' - 1 1/2"	0' - 10 3/4"						348	679
ED040302	1' - 4"	0' - 6"	1' - 4"						132	280
ED040400	1' - 1"	1' - 10"	1' - 1"						12	33
ED040406	2' - 0"	0' - 6"	2' - 0"						18	55
ED053803	37' - 3"	0' - 6"	0' - 6"						690	27528
ED060600	5' - 0"	0' - 6"	0' - 6"						1198	10797
ED061306	12' - 6"	0' - 6"	0' - 6"						40	812
ED061606	15' - 6"	0' - 6"	0' - 6"						40	992
ED061906	18' - 6"	0' - 6"	0' - 6"						40	1172
EK041001	3' - 5 1/12"	0' - 10 1/4"	1' - 0 1/4"	1' - 3 1/2"					10	67
EL040707	2' - 6"	0' - 7"	2' - 2"	1' - 2"	0' - 0"	0' - 7"			1056	5350
EM040907	0' - 10 1/4"	2' - 11 1/2"	1' - 3 1/2"	1' - 11 1/2"	1' - 0 1/4"	1' - 6"			42	269
ET060708	1' - 0"	1' - 4"	1' - 2 7/8"	1' - 8"	0' - 6 1/4"	0' - 8"			672	7739
EW040603	0	1' - 8 1/2"	1' - 3"	1' - 8 1/2"	0	1' - 10"	2' - 6"	2' - 6"	16	67
EW040707	0	2' - 0 1/2"	1' - 7"	2' - 0 1/2"	0	2' - 2 3/8"	3' - 0"	3' - 0"	16	82

SUPERSTRUCTURE - STAGE II

BAR	DIMENSIONS								NO. REQ'D	TOTAL WT.
	a	b	c	d	e	f	g	h		
EA040306	3' - 6"								152	356
EA040609	6' - 9"								4	19
EA042000	20' - 0"								16	214
EA043206	32' - 6"								464	10074
EA043600	36' - 0"								28	674
EA044006	40' - 6"								232	6277
EA044800	48' - 0"								232	7439
EA044806	48' - 6"								464	15033
EA053703	37' - 3"								690	26808
EA060609	6' - 9"								696	7057
EA062200	22' - 0"								188	6213
EA063600	36' - 0"								80	4326
EA063806	38' - 6"								176	10178
EA064100	41' - 0"								88	5420
ED040211	0' - 10 3/4"	1' - 1 1/2"	0' - 10 3/4"						348	679
ED040302	1' - 4"	0' - 6"	1' - 4"						94	199
ED040400	1' - 1"	1' - 10"	1' - 1"						12	33
ED040406	2' - 0"	0' - 6"	2' - 0"						18	55
ED053803	37' - 3"	0' - 6"	0' - 6"						690	27528
ED060600	5' - 0"	0' - 6"	0' - 6"						1194	10761
ED061306	12' - 6"	0' - 6"	0' - 6"						30	609
ED061606	15' - 6"	0' - 6"	0' - 6"						30	744
ED061906	18' - 6"	0' - 6"	0' - 6"						28	821
EK041001	3' - 5 1/12"	0' - 10 1/4"	1' - 0 1/4"	1' - 3 1/2"					10	67
EL040707	2' - 6"	0' - 7"	2' - 2"	1' - 2"	1' - 2"	0' - 0"	0' - 7"		1056	5350
EM040907	0' - 10 1/4"	2' - 11 1/2"	1' - 3 1/2"	1' - 11 1/2"	1' - 0 1/4"	1' - 6"			42	269
ET060708	1' - 0"	1' - 4"	1' - 2 7/8"	1' - 8"	0' - 6 1/4"	0' - 8"			672	7739
EW040603	0	1' - 8 1/2"	1' - 3"	1' - 8 1/2"	0	1' - 10"	2' - 6"	2' - 6"	20	84
EW040707	0	2' - 0 1/2"	1' - 7"	2' - 0 1/2"	0	2' - 2 3/8"	3' - 0"	3' - 0"	20	102
EA042200	22' - 0"								2	30
EA042206	22' - 6"								108	1624
EA042306	23' - 6"								7	110
EA042503	25' - 3"								576	9716
EA060109	1' - 9"								768	2019
ED040300	1' - 0"	1' - 0"	1' - 0"						1609	3225
EK040801	0' - 7"	1' - 7"	2' - 5"	2' - 11"					2404	12981

APPROACH

EA042200	22' - 0"								2	30
EA042206	22' - 6"								108	1624
EA042306	23' - 6"								7	110
EA042503	25' - 3"								576	9716
EA060109	1' - 9"								768	2019
ED040300	1' - 0"	1' - 0"	1' - 0"						1609	3225
EK040801	0' - 7"	1' - 7"	2' - 5"	2' - 11"					2404	12981

MISCELLANEOUS QUANTITIES

395,381 Lb Reinforcement, Steel, Epoxy Coated

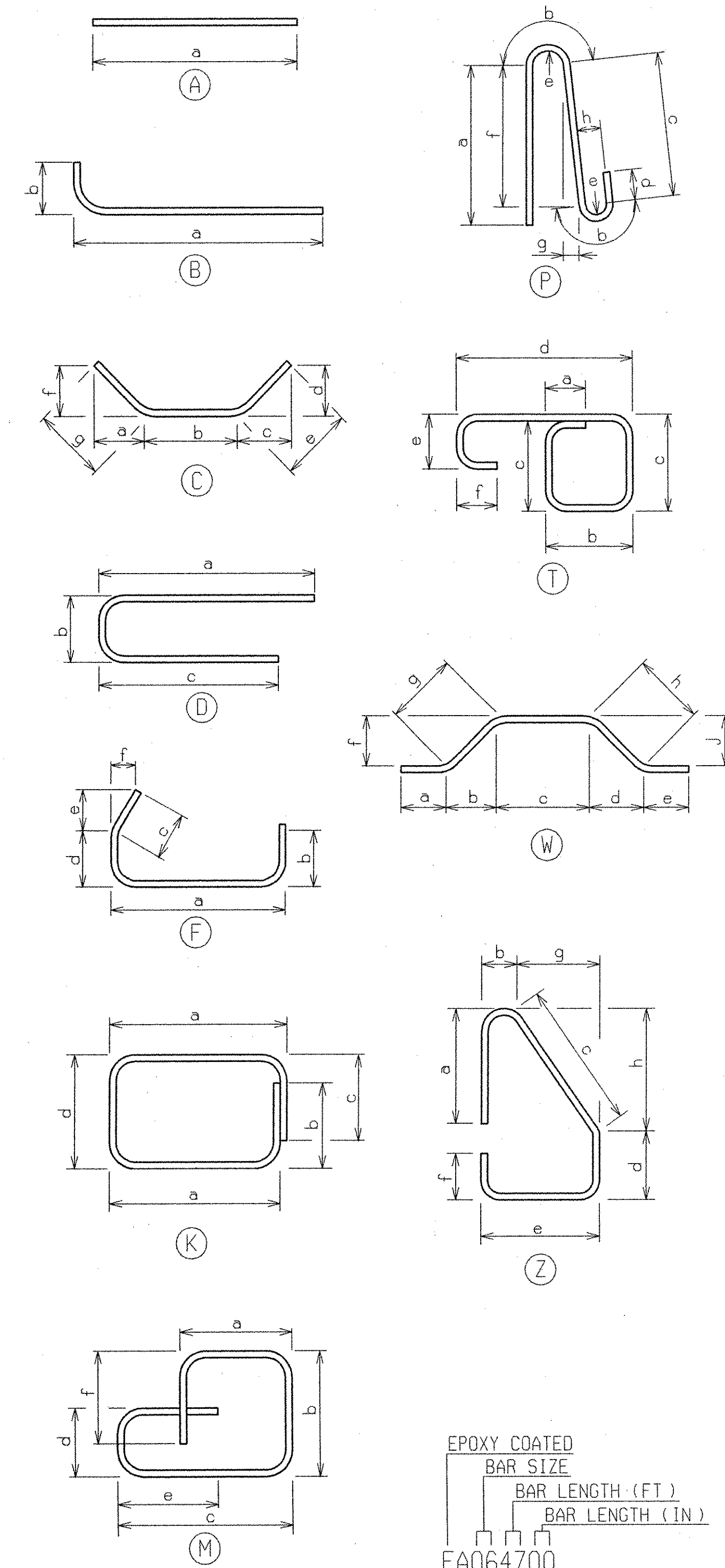

EPOXY COATED
BAR SIZE
BAR LENGTH (FT.)
BAR LENGTH (IN.)
EA064700
BAR SHAPE
BAR LEGEND

NOTE:

REINFORCEMENT SHALL BE BUNDLED AND TAGGED AS TO THE LOCATION AS SHOWN ON THIS SHEET.

REVISIONS	DESCRIPTION	DATE	BY



EAST GRAND BLVD OVER
DETROIT CONNECTING RAILROAD
MDOT JOB NO. 86173A STRUCTURE NO. R01 of 82-22-54

STEEL REINFORCEMENT DETAILS

DATE:	04/16/08
DLZ JOB NO.	0642-6090-00
SHEET NO.	34 OF 60

DATE: 07/05/07 CORRECTED BY: DLW
 DATE: 07/02/07 CHECKED BY: KCK
 DATE: 07/02/07
 DRAWN BY: DLW
 FILE NAME: east_grand_app1.dgn

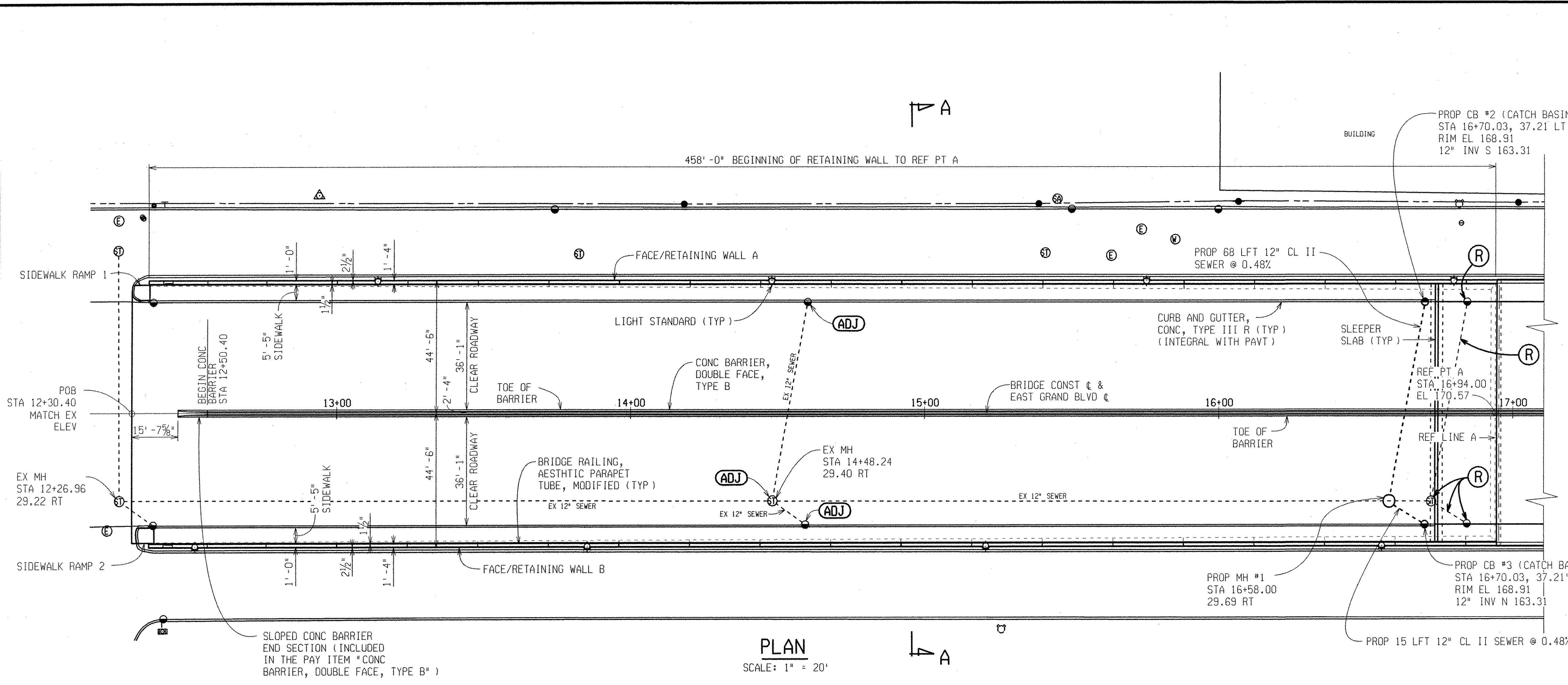
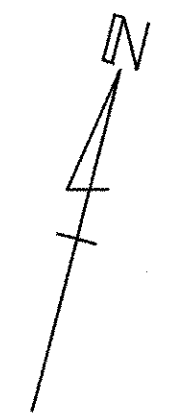

LEGEND	
ADJUST DR STR RIM	(ADJ)
REMOVE	(R)

PLAN
SCALE: 1" = 20'

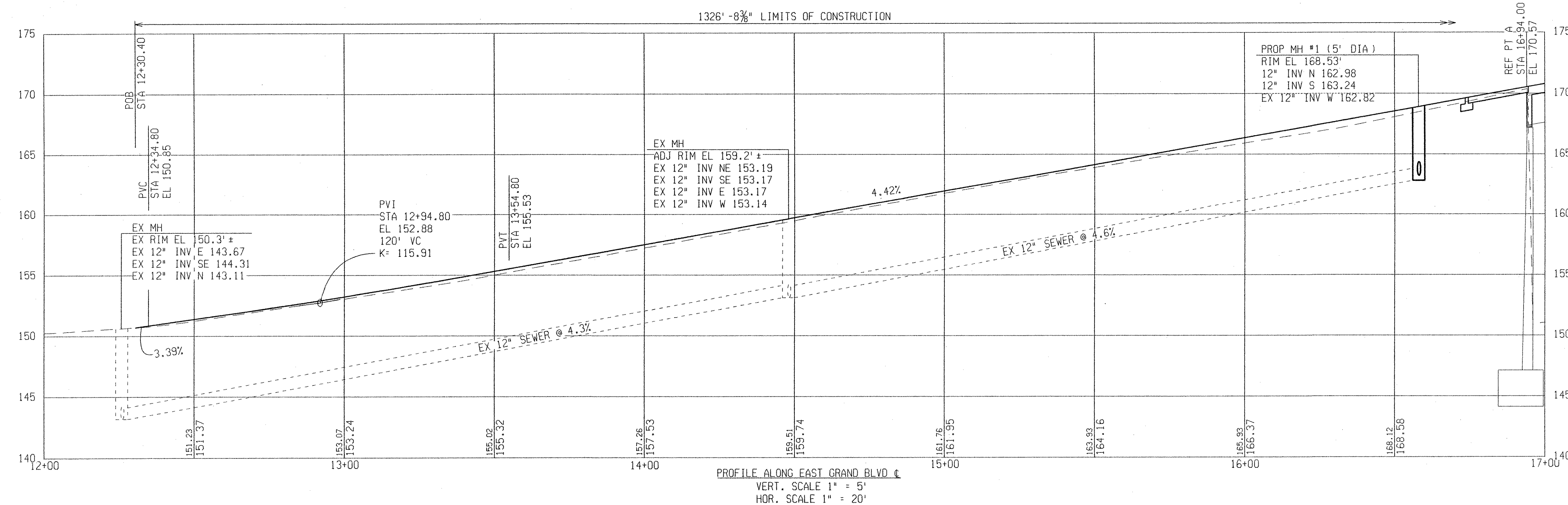

SIDEWALK RAMP, ADA, MODIFIED*

RAMP	TYPE	A	B	C	D	E
1	R	150.99	150.09	12'-0"	8.3%	5'-0"
2	R	150.99	149.99	12'-0"	8.3%	5'-0"

*SEE MDT STANDARD PLAN R-28-F FOR DETAILS

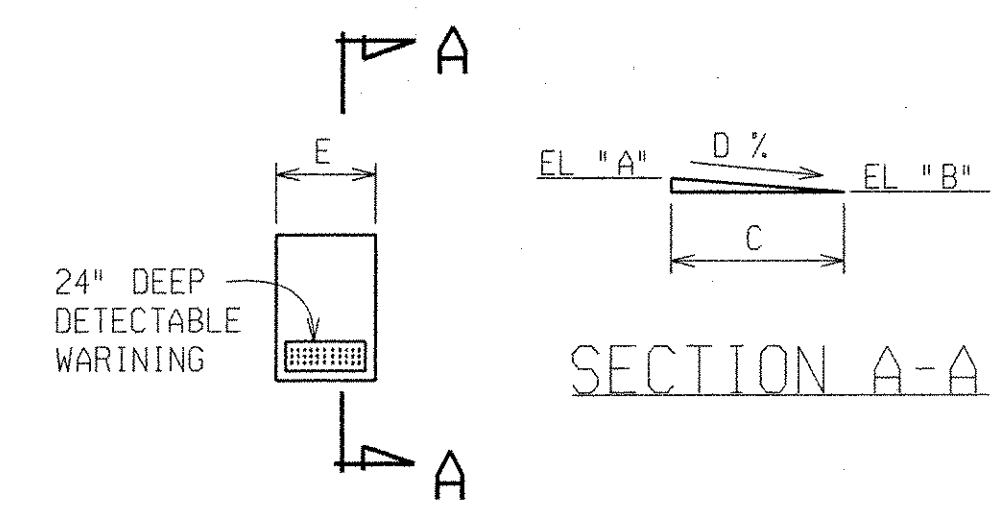

SIDEWALK RAMP TYPE R

REVISIONS	DESCRIPTION	DATE	BY

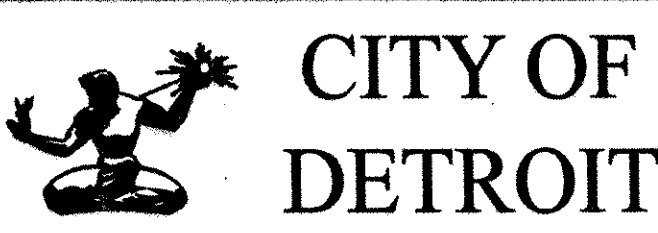

**EAST GRAND BLVD OVER
DETROIT CONNECTING RAILROAD**
 MDOT JOB NO. 86173A STRUCTURE NO. R01 of 82-22-54

APPROACH DETAILS

DATE: 04/16/08
 DLZ JOB NO. 0642-6090-00
 SHEET NO. 35 OF 60

DATE: 07/02/07 CORRECTED BY: DLW
 DATE: 07/02/07 CHECKED BY: KCK
 DATE: 07/02/07 DRAWN BY: DLW
 FILE NAME: east_grand_app2.dgn

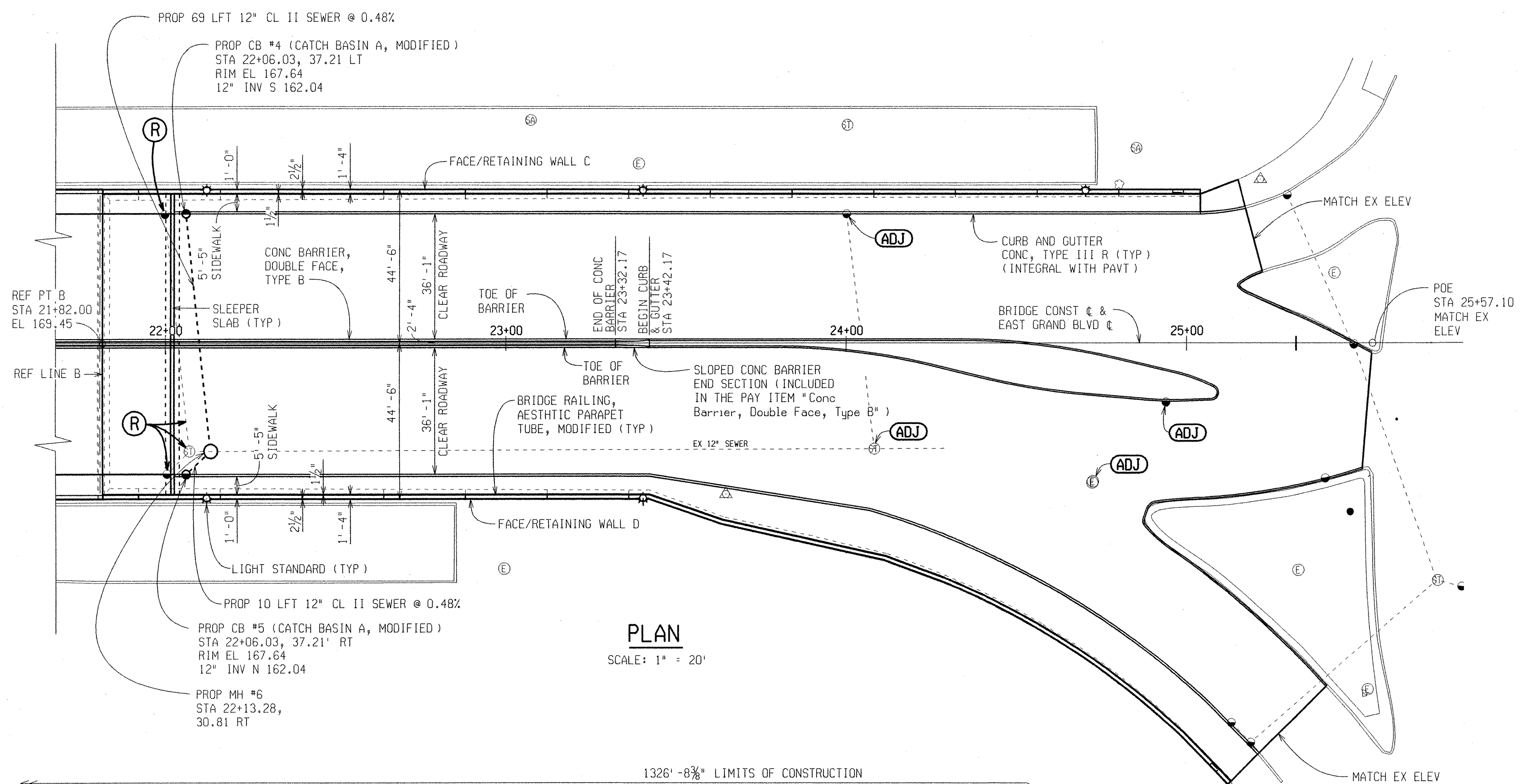

PLAN
 SCALE: 1" = 20'

LEGEND:

ADJUST DR STR RIM	(ADJ)
REMOVE	(R)

MISCELLANEOUS QUANTITIES

1	LS	Mobilization, Max
6	Ea	Dr Structure, Rem
185	Ft	Sewer, Rem, Less Than 24 inch
1400	Ft	Fence, Rem
1070	Syd	Sidewalk, Rem
1700	Ft	Curb, Rem, Modified
7438	Syd	Pavt, Rem Modified
4600	Cyd	Excavation, Earth
3100	Cyd	Granular Material, Cl II, Modified
7251	Syd	Aggregate Base, 4 inch
162	Ft	Sewer, Cl C 76 IV, 12 inch, Tr Det B, Modified
2	Ea	Dr Structure, 60 inch Dia
4	Ea	Catch Basin A, Modified
2700	Lb	Dr Structure Cover, Modified
7	Ea	Dr Structure cover, Adj, Case 2, Modified
6670	Syd	Conc Pavt with Integral Curb, Reinf, 9 inch, Modified
120	Sft	Sidewalk Ramp, ADA
9000	Sft	Sidewalk, Conc, 4 inch Modified
570	Ft	Conc Barrier, Double Face, Type B
1400	Sft	Fence, Structure
103	Cyd	Substructure Conc
1592	Ft	Bridge Railing, Aesthetic Parapet Tube, Modified
1835	Ea	Adhesive anchoring of Vertical Bar, 3/4 inch
162	Ft	Video Taping Sewer and Culv Pipe
100	Cyd	Non Haz Contaminated Material Handling and Disposal, LM
1400	Ft	Pavt Mrkg, Thermopl, 4 inch, White
2800	Ft	Pavt Mrkg, Thermopl, 4 inch, Yellow

NOTES:
 PROPOSED PAVEMENT MARKINGS SHALL MATCH THE EXISTING PAVEMENT MARKINGS, AND SHALL BE ACCORDING TO CITY OF DETROIT D.P.W. TRAFFIC ENGINEERING DIVISION STANDARDS.

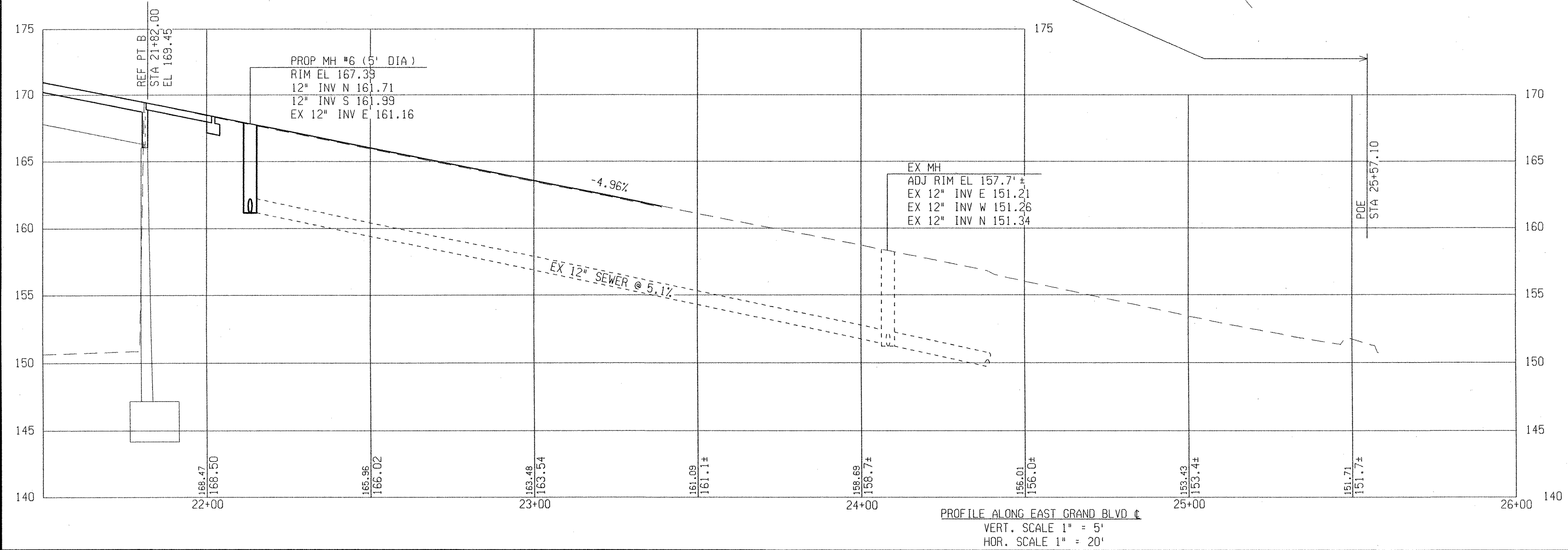

PROFILE ALONG EAST GRAND BLVD
 VERT. SCALE 1" = 5'
 HOR. SCALE 1" = 20'

REVISIONS	DESCRIPTION	DATE	BY

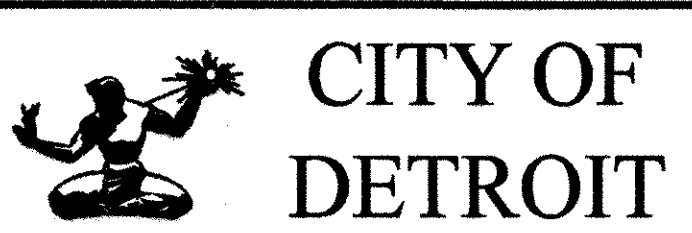

**EAST GRAND BLVD OVER
 DETROIT CONNECTING RAILROAD**
 MDOT JOB NO. 86173A STRUCTURE NO. R01 of 82-22-54

APPROACH DETAILS

DATE: 04/16/08
 DLZ JOB NO. 0642-6090-00
 SHEET NO. 36 OF 60

DATE: 07/02/07

CORRECTED BY: DLW

CHECKED BY: KCK

DATE: 07/02/07

DRAWN BY: DLW

FILE NAME: east grand st5.dgn

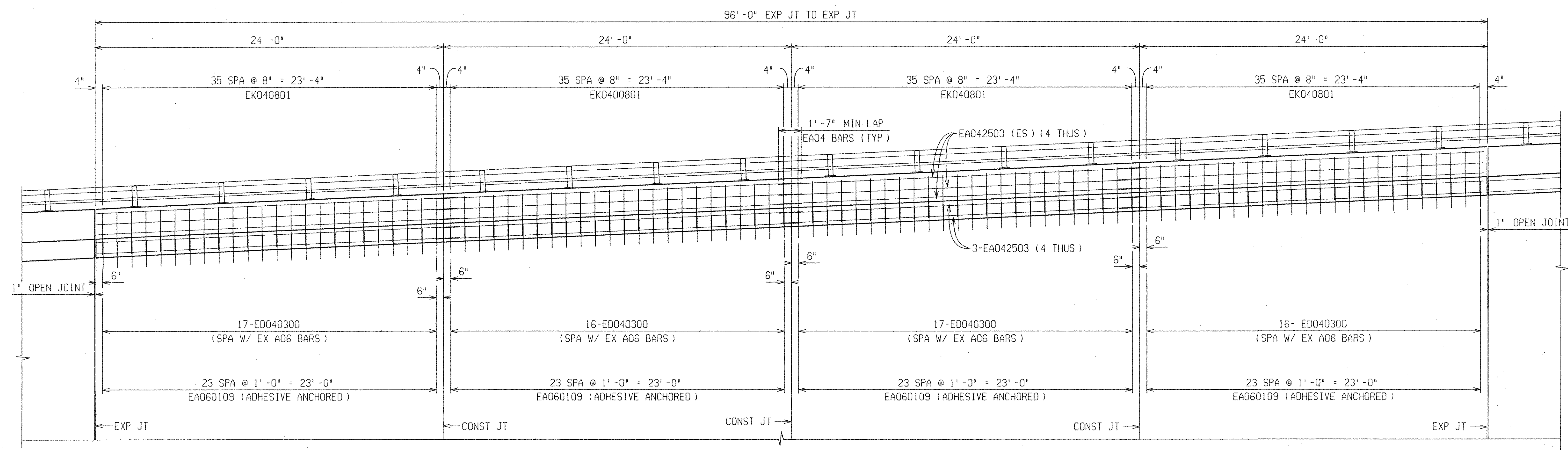

TYPICAL APPROACH RAILING DETAIL
(12 SECTIONS TOTAL)

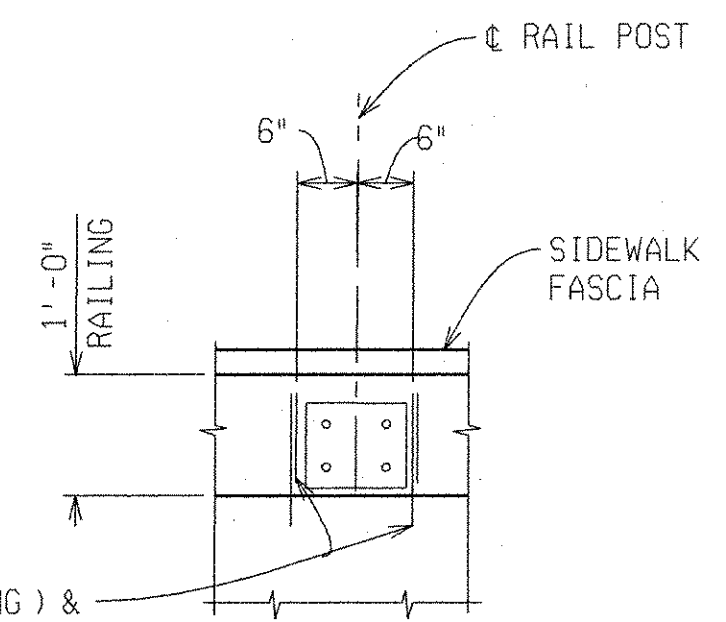

EKO40801 (IN RAILING) &
ED040300 (IN WALL)

RAILING POST DETAIL
(TYP 203 POSTS ON THE APPROACH)

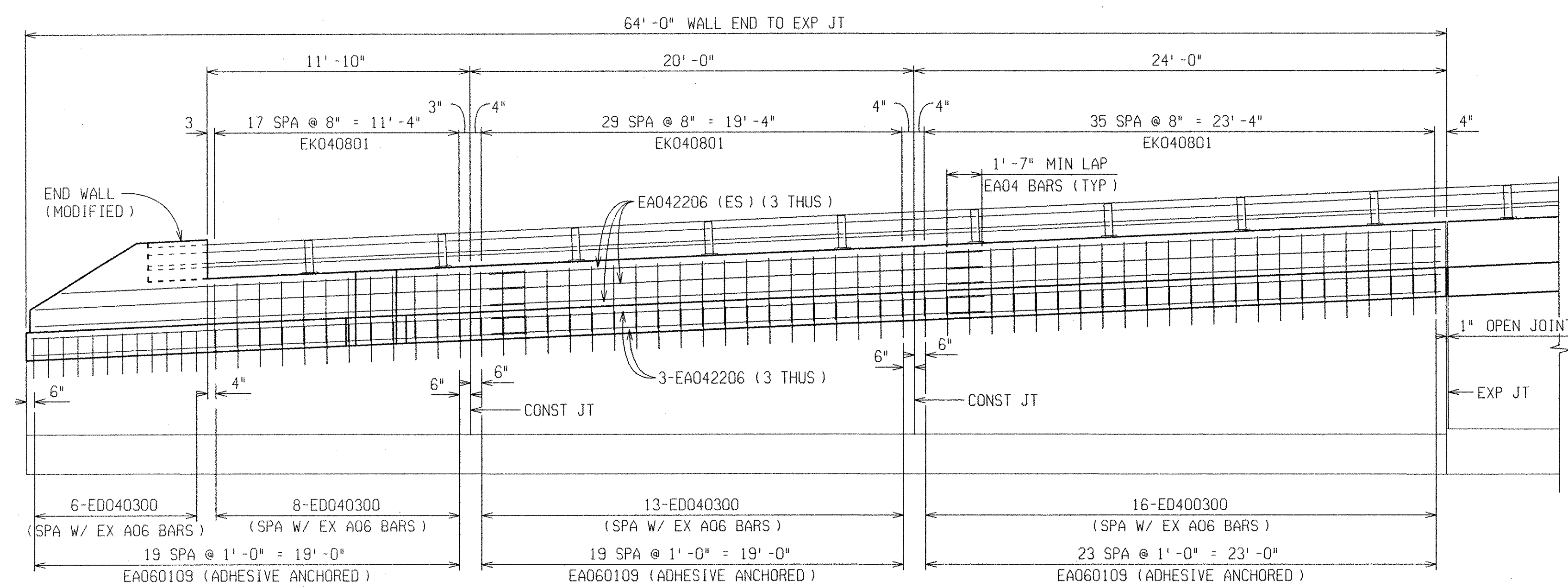

TYPICAL APPROACH RAILING END DETAIL
(RETAINING WALL A, B & D)

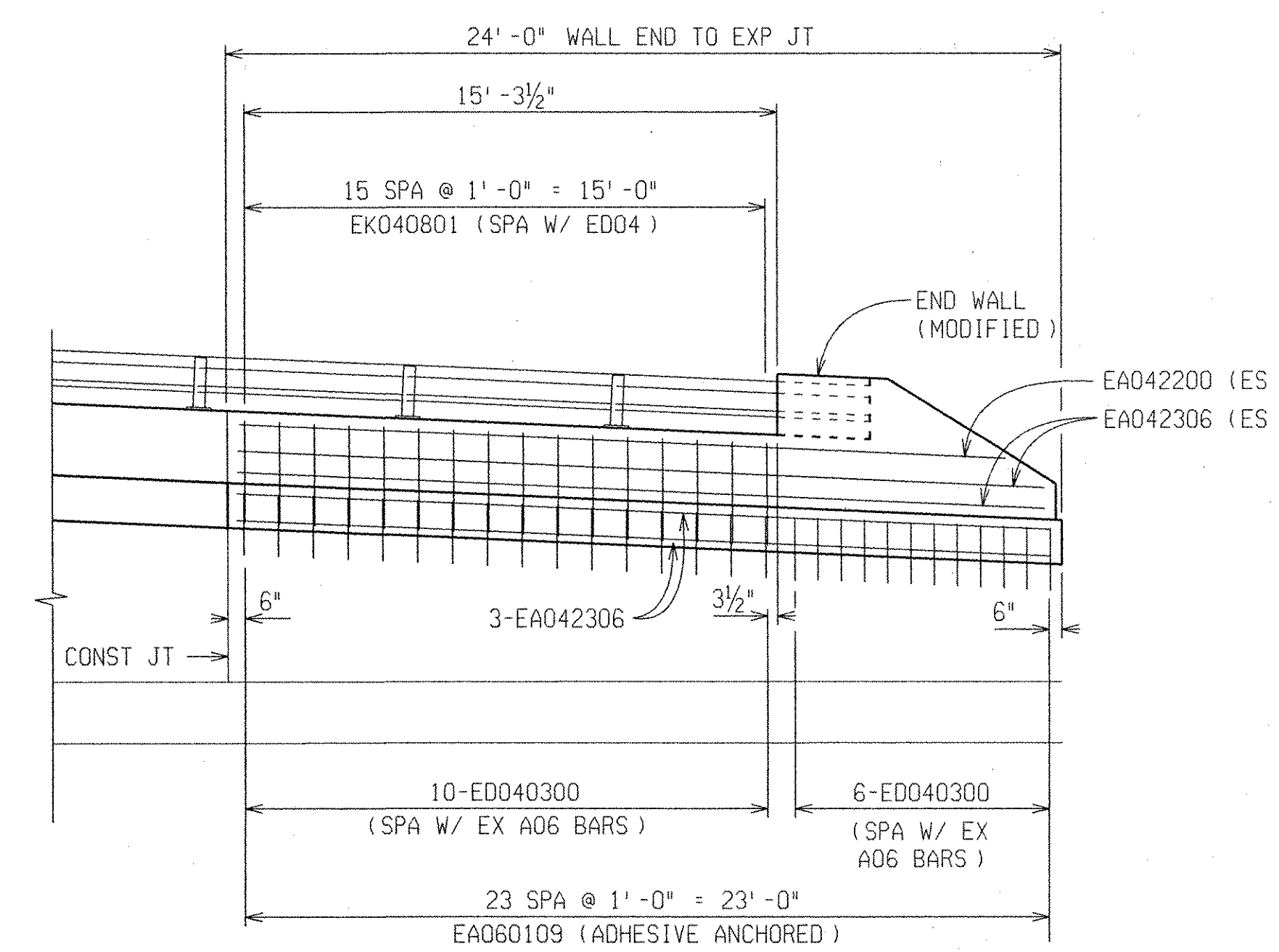

TYPICAL APPROACH RAILING END DETAIL
(RETAINING WALL C)

NOTE:
FOR END BLOCK REINFORCEMENT SEE SHEET

REVISIONS	DESCRIPTION	DATE	BY

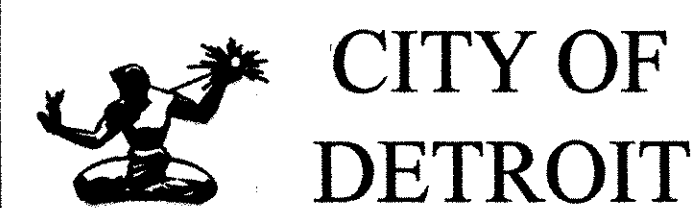

EAST GRAND BLVD OVER
DETROIT CONNECTING RAILROAD
MDOT JOB NO. 86173A STRUCTURE NO. R01 of 82-22-54

APPROACH DETAILS

DATE: 04/16/08
DLZ JOB NO. 0642-6090-00
SHEET NO. 37 OF 60

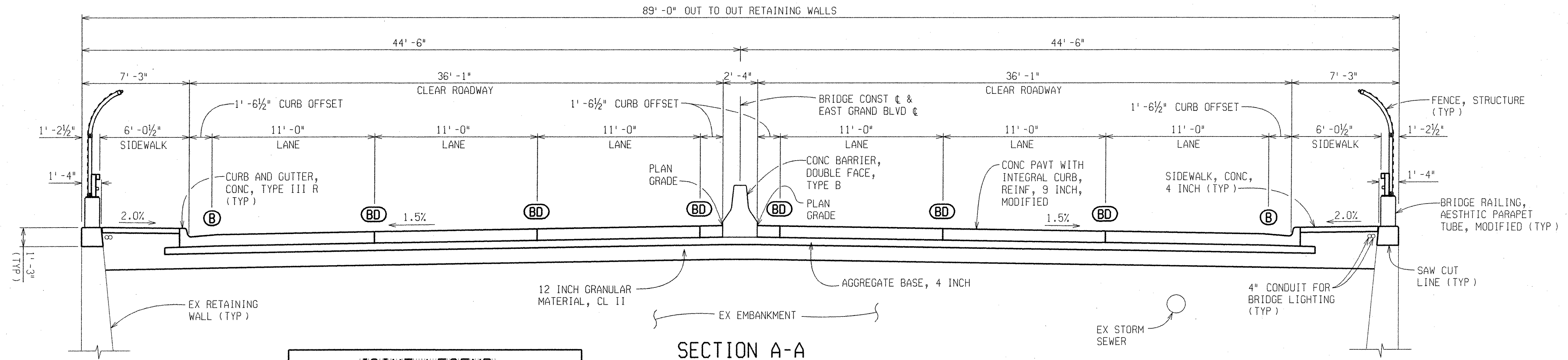

JOINT LEGEND

- (B) LONGITUDINAL BULKHEAD JOINT
- (D) LONGITUDINAL LANE TIE JOINT
- (BD) OPTION (B) OR (D) JOINT
- (E5) LONGITUDINAL EXPANSION JOINT WITHOUT TRANSVERSE ASSEMBLY

SECTION A-A

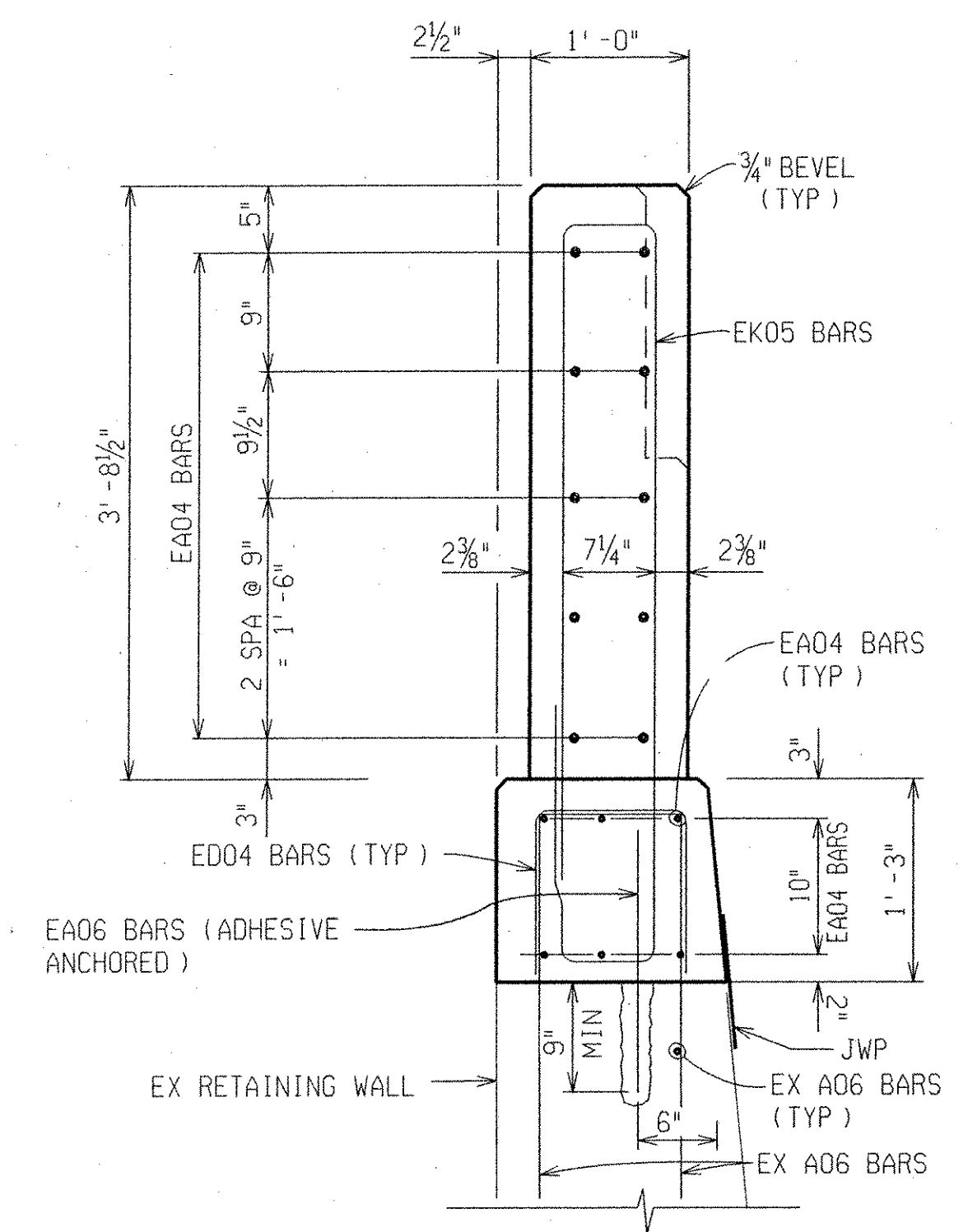

SECTION AT END WALL
(FULL CONCRETE AREA)

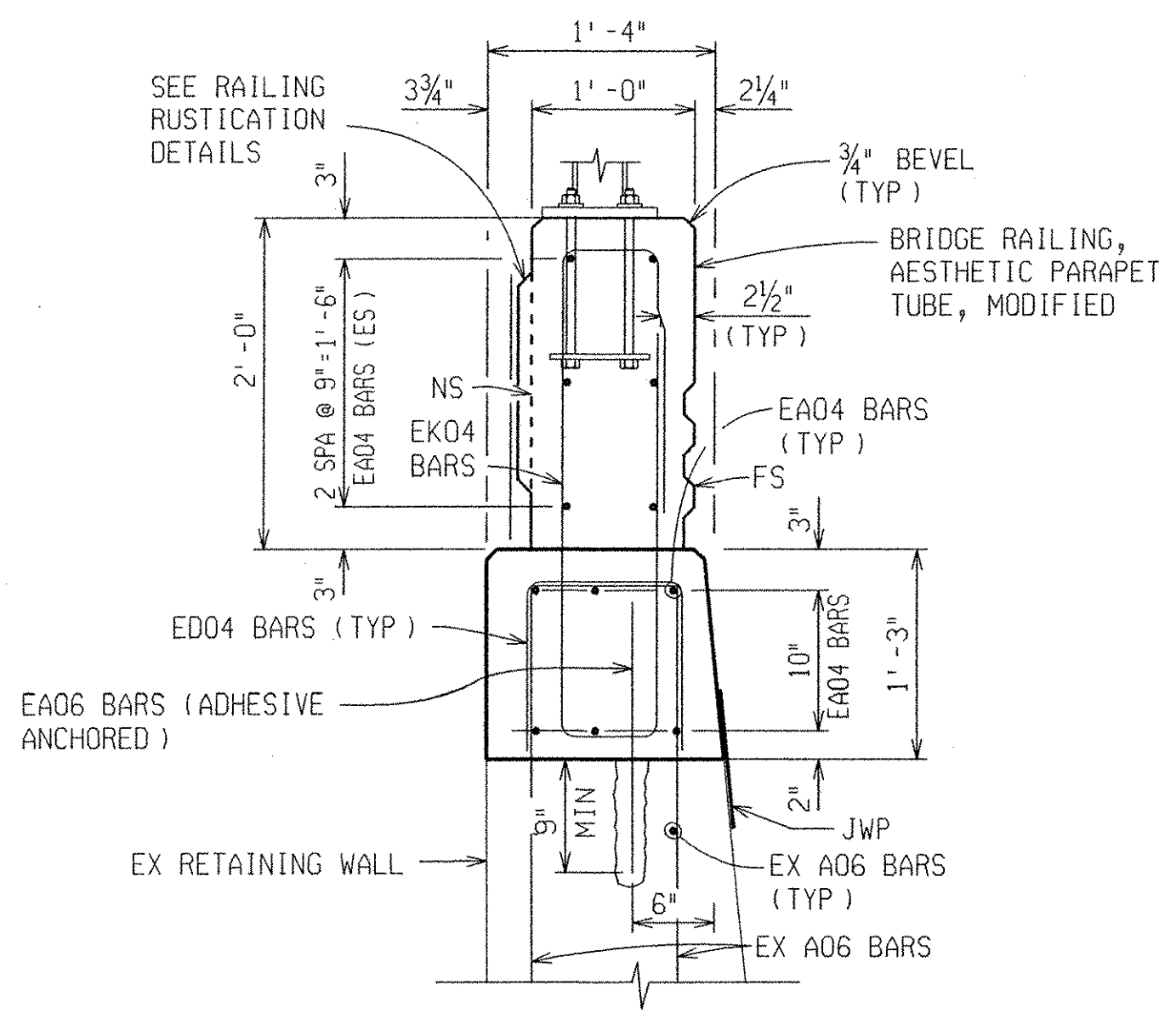

TYPICAL RAILING SECTION

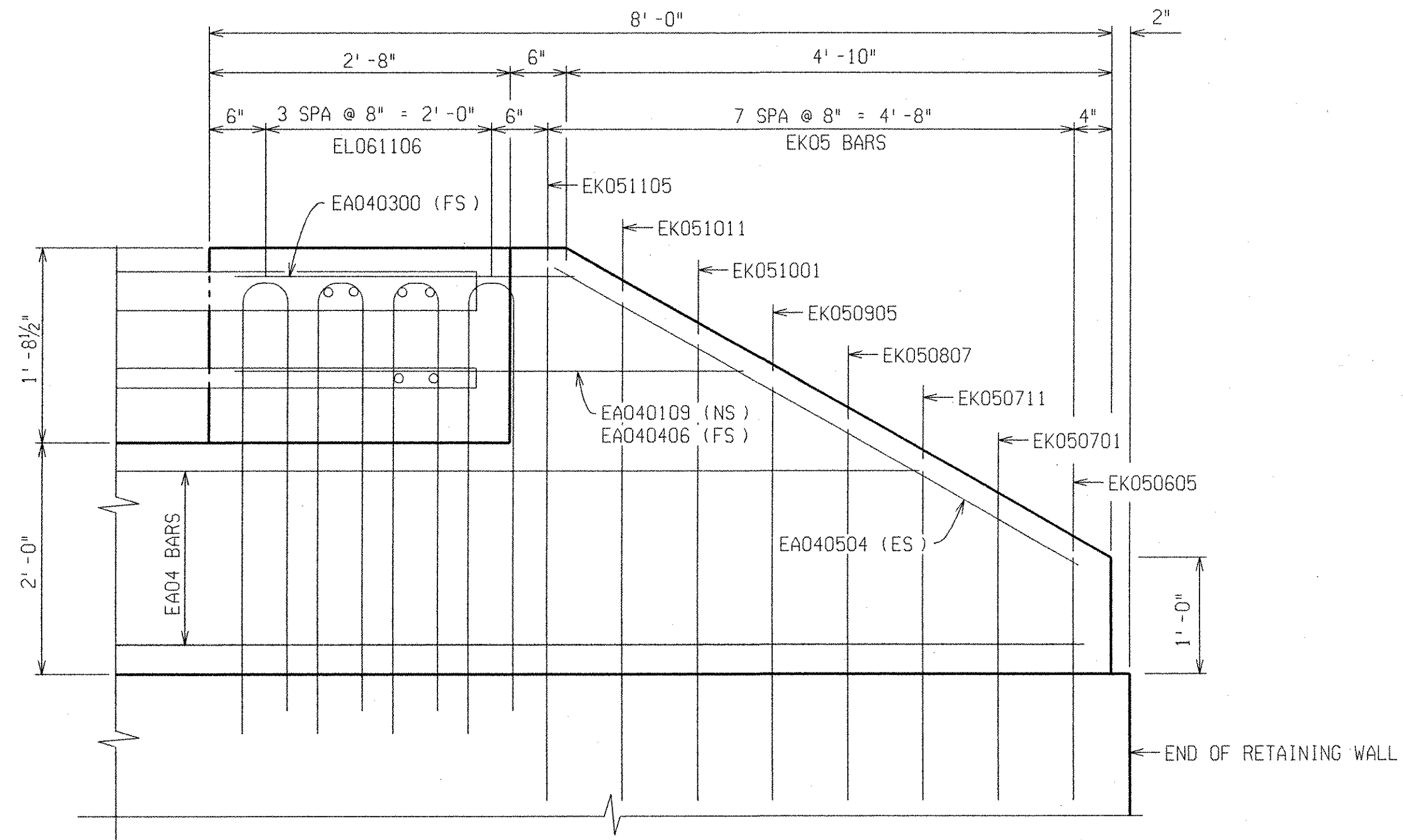

END WALL DETAIL
(TYP 3 CORNERS)

REVISIONS	DESCRIPTION	DATE	BY



EAST GRAND BLVD OVER
DETROIT CONNECTING RAILROAD
MDOT JOB NO. 86173A STRUCTURE NO. R01 of 82-22-54

APPROACH DETAILS

DATE: 04/16/08
DLZ JOB NO. 0642-6090-00
SHEET NO. 38 OF 60

DATE: 07/02/07 CORRECTED BY: DLW
CHECKED BY: KCK
DRAWN BY: DLW
FILE NAME: east_grand_st6.dgn

UNDERGROUND

LEGEND SHEET

- FIRE HYDRANT
- EXISTING MANHOLE
- EXISTING HANDHOLE
- EXISTING DUCT RUN
- ABANDON EXISTING DUCT RUN
- EXISTING DIRECT BURIAL OR PARKWAY CABLE
- ABANDON DIRECT BURIAL OR PARKWAY CABLE
- INSTALL DIRECT BURIAL CABLE (NO. AND SIZE WILL BE SHOWN)
- 5" E.C. BUILD ENCASED CONDUIT (E.C.) (NO. AND SIZE WILL BE SHOWN)
- 2-3" D.B. INSTALL DIRECT BURIAL CONDUIT (D.B.) (NO. AND SIZE WILL BE SHOWN)
- 2-4" J.B. JACKED-BORED CONDUIT (J.B.) (NO. AND SIZE WILL BE SHOWN)
- BUILD NEW MANHOLE (2-WAY)
- BUILD NEW MANHOLE (3-WAY)
- BUILD NEW MANHOLE (4-WAY)
- BUILD NEW MANHOLE (CORNER)
- BUILD NEW HANDHOLE (ROUND OR SQUARE AS INDICATED ON PLANS).
- BUILD POLYMER CONCRETE HANDHOLE
- BUILD TYPE "S" HANDHOLE
- BUILD TYPE "D" HANDHOLE
- EXISTING UNDERGROUND-FED ST. L.T.G. UNIT AND FOUNDATION
- REMOVE UNDERGROUND-FED ST. L.T.G. UNIT AND FOUNDATION (EXCEPT AS OTHERWISE NOTED)
- INSTALL CODE 009-00 ST. L.T.G. STD. WITH 6FT. CLAMP-ON BRACKET ARMS (3'-0" RISE), ON BRIDGE OR RETAINING WALL. INSTALL 250W. 240V. SODIUM VAPOR LUMINAIRE. SEE P.L.D. DETAILS.
- SALVAGED UNDERGROUND-FED ST. L.T.G. UNIT ON NEW FOUNDATION.

DIAGRAMS

- INDICATES 2000V., 1-1/C #6 ST. L.T.G. CABLE
- INDICATES 2000V., 1-1/C #6 ST. L.T.G. CABLE & 1-#6 NEUTRAL.
- INDICATES 2000V., 2-1/C #6 ST. L.T.G. CABLES & 1-#6 NEUTRAL (ALL UNLABELED CABLE GROUPS ON WIRING DIAGRAM ARE SUCH.) 480/960V.
- INDICATES 2000V., 1-1/C #2 ST. L.T.G. CABLE
- INDICATES 2000V., 1-1/C #2 ST. L.T.G. CABLE & 1-#2 NEUTRAL.
- INDICATES 2000V., 2-1/C #2 ST. L.T.G. CABLES & 1-#2 NEUTRAL (ALL UNLABELED CABLE GROUPS ON WIRING DIAGRAM ARE SUCH.) 240/480V.
- INDICATES 2000V., 3-1/C #2 ST. L.T.G. CABLES & 1-#2 NEUTRAL.
- INDICATES REMOVE CABLES IN CONDUIT (REGARDLESS OF SIZE OR NUMBER OF CABLES IN THE CONDUIT.)
- INSTALL 7500V., 1-1/C #8 L.C. ST. L.T.G. CABLE
- INSTALL 7500V., 2-1/C #8 L.C. ST. L.T.G. CABLES

OVERHEAD

- INSTALL OVERHEAD ALLEY L.T.G. UNIT. WITH 1.83m BRACKET ARM.
- INSTALL OVERHEAD RESIDENTIAL L.T.G. (4.88m ARM WITH TYPE I 4-WAY LUMINAIRE SHOWN)
- INSTALL OVERHEAD RESIDENTIAL L.T.G. UNIT (3.048m ARM WITH TYPE II 2-WAY LUMINAIRE SHOWN)
- EXISTING WOOD POLE OR REMOVE IF NOTED (AMERITECH POLE SHOWN)
- REMOVE WOOD POLE (P.L.D. POLE SHOWN)
- REPLACE WOOD POLE (HEIGHT & CLASS AS INDICATED)
- INSTALL WOOD POLE (HEIGHT & CLASS AS INDICATED) (USE SALVAGED POLE WHERE INDICATED)
- EXISTING OVERHEAD ST. L.T.G. UNIT
- REMOVE OVERHEAD ST. L.T.G. UNIT (D.E. CO. POLE SHOWN)
- INSTALL OVERHEAD ST. L.T.G. UNIT WITH 8FT. MAIN ST. L.T.G. BRACKET ARM.
- EXISTING OVERHEAD LINE
- REMOVE OVERHEAD LINE
- INSTALL OVERHEAD LINE
- INSTALL AND LATER REMOVE OVERHEAD LINE
- INSTALL GUY AND ANCHOR (3/8" GUY UNLESS OTHERWISE NOTED)
- REMOVE GUY AND ANCHOR ROD
- INSTALL POLE GUY (3/8" GUY UNLESS OTHERWISE NOTED)
- INSTALL ARM GUY (1/4" GUY UNLESS OTHERWISE NOTED)
- REMOVE GUY (POLE OR ARM GUY WILL BE INDICATED)
- RM. MATERIALS TO BE REMOVED
- IN. MATERIALS TO BE INSTALLED
- C.P. CABLE POLE
- EX. EXISTING MATERIALS
- M.S.S. MAKE WOOD POLE SELF-SUPPORTING IN CRUSHED STONE
- XYZ PHASES OF P.L.D. DISTRIBUTION WIRES OR EQUIPMENT
- E D.E. CO. DISTRIBUTION WIRE
- e.s. D.E. SECONDARY WIRE
- ctv CABLE TELEVISION
- C INSTALL SUSPENSION INSULATOR
- EXISTING PROPOSED C P.L.D. DISTRIBUTION WIRE
- EXISTING PROPOSED CS P.L.D. SECONDARY WIRE
- EXISTING PROPOSED A P.L.D. SERIES ST. L.T.G. WIRE
- EXISTING PROPOSED M P.L.D. MULT. ST. L.T.G. WIRE

GENERAL

- BUILDING (STRUCTURE)
- GUARD RAIL (CONCRETE)
- GUARD RAIL (STEEL)
- CENTER LINE (CL)
- PROPERTY LINE (PL) OR RIGHT OF WAY (ROW)
- PAVEMENT JOINTLINE AND CURB
- CURB LINE
- EXISTING ROUND CATCH BASIN
- EXISTING RECTANGLE CATCH BASIN
- EXISTING SEWER LINE, MANHOLE AND CATCH BASIN
- EXISTING DETROIT EDISON UNDERGROUND LINE AND MANHOLE
- EXISTING AMERITECH TELEPHONE UNDERGROUND LINE AND MANHOLE
- EXISTING GAS LINE AND MANHOLE
- EXISTING WATER LINE AND HANDHOLE
- EXISTING DETROIT PUBLIC LIGHTING UNDERGROUND LINE AND HANDHOLE.
- EXISTING DETROIT EDISON UNDERGROUND STEAM LINE
- EXISTING CABLE TELEVISION
- EXISTING R.R. TRACKS
- EXISTING STREETCAR TRACKS
- EXISTING FENCE
- EXISTING PUBLIC TELEPHONE
- EXISTING TELEPHONE CONTROL BOX
- EXISTING TRANSFORMER OR NOTED AS REMOVE
- NEW TRANSFORMER
- EXISTING R.R. CROSSING GATE AND FLASHERS
- EXISTING R.R. FLASHERS
- EXISTING R.R. CROSSING MAST ARM AND FLASHERS
- EXISTING DOUBLE POST SIGN (TYPE SHOWN ON PLANS)
- INSTALL DOUBLE POST SIGN (TYPE SHOWN ON PLANS)
- EXISTING SINGLE POST SIGN (TYPE SHOWN ON PLANS)
- INSTALL SINGLE POST SIGN (TYPE SHOWN ON PLANS)
- EXISTING MAST ARM ROAD SIGN (TYPE SHOWN ON PLANS)

TRAFFIC SIGNAL

- POCH POLE CONTACT HEIGHT OF TRAFFIC SIGNAL SPAN WIRE
- L.C.H. LOWEST CONTACT HEIGHT OF TRAFFIC SIGNAL TO SPAN WIRE.
- REMOVE HOOD AND INSTALL LAMPS (INCIDENTAL TO INSTALLATION OF TRAFFIC SIGNAL ON THIS CONTRACT)
- BACK-OUT LAMPS AND HOOD (SIGNALS INCLUDED IN THE INSTALLATION OF TRAFFIC SIGNAL ON THIS CONTRACT).
- EXISTING STOP BAR
- STOP BAR TO BE INSTALLED
- INSTALL 3-SECTION TRAFFIC SIGNAL (1-WAY SHOWN)
- INSTALL 3-SECTION TRAFFIC SIGNAL WITH SALVAGED HEADS (2-WAY SHOWN)
- REMOVE 3-SECTION TRAFFIC SIGNAL (3-WAY SHOWN)
- EXISTING 3-SECTION TRAFFIC SIGNAL (4-WAY SHOWN)
- INSTALL 3-SECTION 300mm(12") TRAFFIC SIGNAL (2-WAY SHOWN)
- EXISTING 1 OR 2-SECTION 300mm(12") TRAFFIC SIGNAL FLASHERS
- INSTALL 1 OR 2-SECTION 300mm(12") TRAFFIC SIGNAL FLASHERS
- INSTALL TWO-WAY ILLUMINATED CASE SIGN
- INSTALL TWO-WAY ILLUMINATED CASE SIGN (SALVAGED)

- REMOVE TWO-WAY ILLUMINATED CASE SIGN
- EXISTING TWO-WAY ILLUMINATED CASE SIGN
- INSTALL FOUR-WAY ILLUMINATED CASE SIGN
- INSTALL FOUR-WAY ILLUMINATED CASE SIGN (SALVAGED)
- REMOVE FOUR-WAY ILLUMINATED CASE SIGN
- EXISTING FOUR-WAY ILLUMINATED CASE SIGN
- INSTALL 2-SECTION, 300mm(12") PEDESTRIAN (WALK-DON'T WALK) TRAFFIC SIGNAL (2-WAY SHOWN)
- INSTALL 2-SECTION, 300mm(12") PEDESTRIAN (WALK-DON'T WALK) TRAFFIC SIGNAL WITH SALVAGED HEAD (2-WAY SHOWN)
- REMOVE 2-SECTION, PEDESTRIAN (WALK-DON'T WALK) TRAFFIC SIGNAL (1-WAY SHOWN)
- EXISTING 2-SECTION, 300mm(12") PEDESTRIAN (WALK-DON'T WALK) TRAFFIC SIGNAL (1-WAY SHOWN)
- INSTALL TRAFFIC SIGNAL CONTROLLER (NEW OR SALVAGED AS SHOWN) (EXCEPT AS OTHERWISE NOTED).
- INSTALL MAST ARM STD. & MAST ARM ON NEW FOUNDATION (EXCEPT AS OTHERWISE NOTED).
- INSTALL TRAFFIC SIGNAL PEDESTAL ON NEW FOUNDATION (EXCEPT AS OTHERWISE NOTED).
- INSTALL 9.14m(30') ANCHOR BASE STEEL STRAIN POLE ON NEW FOUNDATION (EXCEPT AS OTHERWISE NOTED). (USE 400mm(16") BOLT CIRCLE FOR ALL NEW STRAIN POLES).
- EXISTING TRAFFIC SIGNAL CONTROLLER
- EXISTING MAST ARM STANDARD
- EXISTING PEDESTAL
- EXISTING STEEL STRAIN POLE
- INSTALL OVERHEAD PLASTIC JACKETED CABLE (P.J.)
- EXISTING OVERHEAD PLASTIC JACKETED CABLE (P.J.)
- REMOVE OVERHEAD PLASTIC JACKETED CABLE (P.J.)
- INSTALL JUNCTION BOX (J.B.)
- INSTALL SALVAGED JUNCTION BOX (J.B.)
- REMOVE JUNCTION BOX (J.B.)
- EXISTING JUNCTION BOX (J.B.)
- EXISTING LOOP DETECTOR
- INSTALL LOOP DETECTOR

DIAGRAMS

(U.G.-FED. ST. L.T.G. STD. SYMBOLS ARE THE SAME AS THE UNDERGROUND LEGEND ON THIS SHEET).

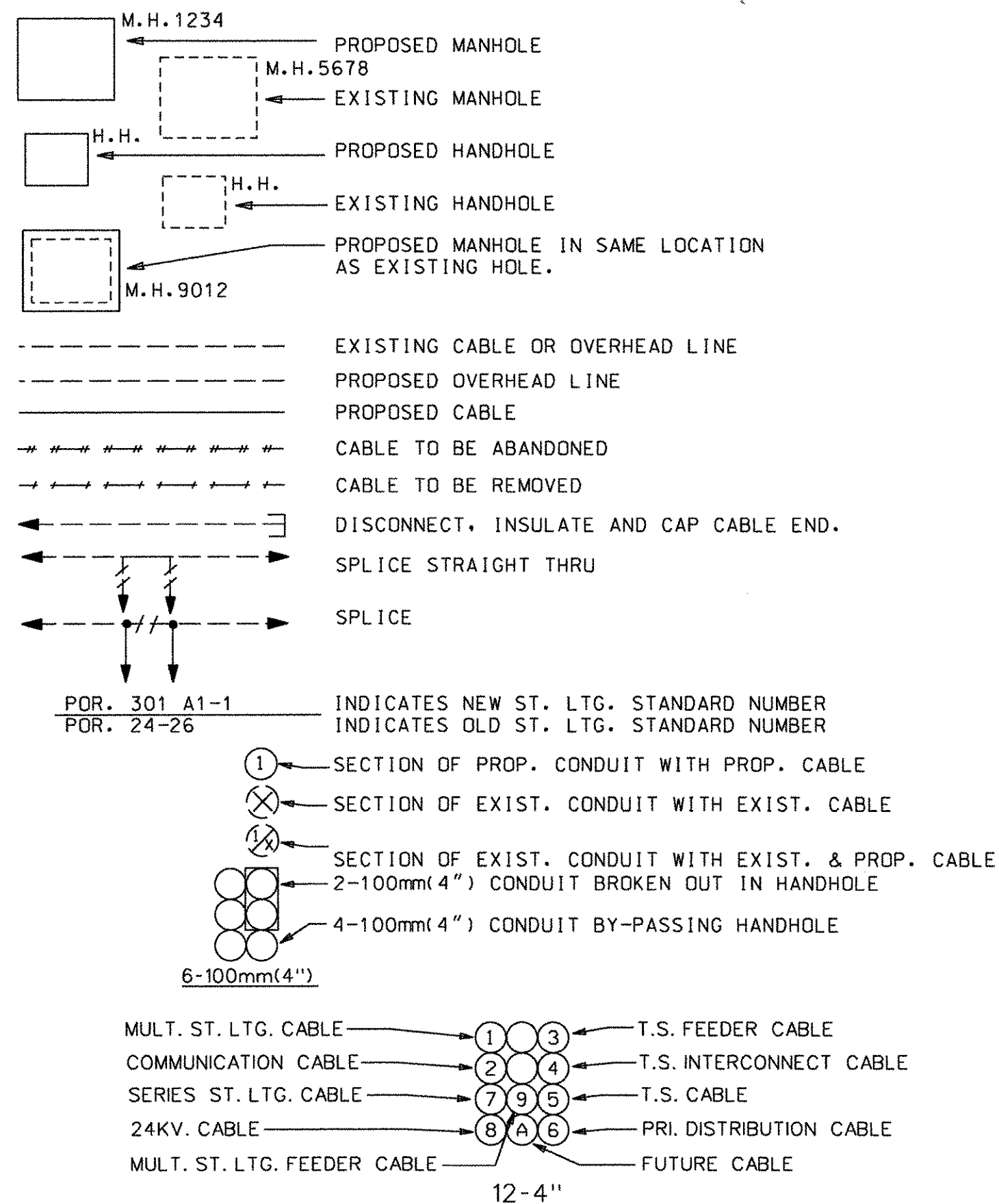

CONTRACTOR TO FURNISH AND INSTALL ALL MATERIALS. P.L.D. SHALL APPROVE ALL SHOP DRAWINGS.

P.L.D. SPECIFICATIONS AND DETAILS SHALL BE USED FOR ALL MATERIALS AND INSTALLATION.

ALL LUMINAIRES WITH BALLASTS SHALL HAVE REGULATED BALLASTS ±10%V.

CAUTION!-CABLE FIREPROOFING MAY CONTAIN ASBESTOS

PLAN INDEX	
DRWG. NO.	SUB-TITLE
1	LEGEND
2	GENERAL INFORMATION
3 - 4	GENERAL PLANS
5	WIRING DIAGRAM
6 - 17	DETAILS

DATE PLOTTED: 04/25/08

Computer: r12-er; en: Table File

Date	Description	Chkd. by

**IMPROVEMENT OF STREET LIGHTING
EAST GRAND BOULEVARD BRIDGE
GENERAL PLAN**

Designed by C.E.A.	Checked by ---
Drawn by ---	Checked by ---
Checked by ---	Approved by ---

Consulting Engineering Associates, Inc.
16580 WYOMING AVE. DETROIT MICHIGAN 48221
TELEPHONE: (313) 341-5797 FAX: 341-0205

Disk File Name: RR-LG Job File No.: CEA 138200

Scale: _____
Checked by: _____
Approved by: _____

PUBLIC LIGHTING DEPARTMENT
CITY OF DETROIT

File No.: 51-0686
Sheet No.: 39 of 60
Date: 3-03-08

GENERAL INFORMATION

1. CALL MISS DIG (313) (647-7344) THREE WORKING DAYS PRIOR TO ANY EXCAVATION FOR THE LOCATIONS OF UNDERGROUND UTILITIES.
2. A MINIMUM CLEARANCE OF 0.915m(3.0') HORIZONTAL & 0.3048m(1.0') VERTICAL MUST BE MAINTAINED BETWEEN PROPOSED P.L.D. FACILITIES & EXISTING U.G. UTILITIES EXCEPT WATER WHICH REQUIRES A 1.07m(3.5') CLEARANCE.
3. CONTRACTOR TO NOTIFY MICHIGAN CONSOLIDATED GAS CO. AT (313) 491-6301 IF PROTECTIVE COATED GAS MAIN IS EXPOSED OR DAMAGED.
4. CONTRACTOR TO NOTIFY D.E. CO., AT 1-800-477-4747 IF PROTECTIVE COATING OF ANY D.E.CO. HIGH VOLTAGE UNDERGROUND LINE IS EXPOSED OR DAMAGED.
5. ALL EXISTING P.L.D. LIGHTING, TRAFFIC SIGNAL, PRIMARY, TRANSMISSION ETC. CIRCUITS SHALL ALWAYS BE MAINTAINED IN AN OPERATIONAL CONDITION (EXCEPT WHERE OTHERWISE NOTED). NOTIFY P.L.D. SYSTEM OPERATOR AT (313) 961-1364 48 HOURS PRIOR TO BEGINNING WORK ON P.L.D. CIRCUITS & KEEP OPERATOR INFORMED ON A DAILY BASIS.
6. EXISTING OVERHEAD & TRAFFIC SIGNAL FACILITIES ARE NOT NECESSARILY SHOWN ON PLANS.
7. CROSSARMS SHALL BE REMOVED AFTER ALL CONTACTS ARE REMOVED. (INCLUDED WITH THE REMOVAL OF OVERHEAD LINES).
8. ALL OVERHEAD WIRES & UNDERGROUND CABLES SHALL CONSIST OF COPPER CONDUCTORS AS PER SPECIFICATIONS.
9. ALL REMOVED WOOD POLES & CROSSARMS SHALL BE DELIVERED TO P.L.D. FOR DISPOSAL BY P.L.D.
10. ALL NEW ANCHOR GUYS SHALL BE INSTALLED ON A 1:1 RATIO OR AS NEARLY AS POSSIBLE (EXCEPT WHERE OTHERWISE NOTED). (STRUT GUYS ARE EXCEPTED).
11. ARM GUYS SHALL BE SIEMENS-MARTIN GRADE. ANCHOR AND POLE GUYS SHALL BE EXTRA HIGH STRENGTH GRADE.
12. INSTALL WOOD POLES SO AS NOT TO INTERFERE WITH TRAFFIC OR FUTURE CONSTRUCTION STAGES.
13. ALL SALVAGED WOOD POLES DIRECTED TO BE INSTALLED SHALL BE POLES PREVIOUSLY INSTALLED NEW ON THIS CONTRACT.
14. ALL TRANSFORMER POLES AND CABLE POLES SHALL BE FITTED UP WITH 3.048m(120") ARMS (EXCEPT WHERE OTHERWISE INDICATED).
15. INSTALLATION OF ARMS FOR EQUIPMENT, CUTOUPS, POTHEADS, TRANSFORMER, ETC. NOT SHOWN ON NEW CABLE AND TRANSFORMER POLES SHALL BE INSTALLED AS PER THE DETAIL DRWG. REQUIREMENT AND SHALL BE INCLUDED IN THE FITTING-UP OF THE CABLE AND/OR TRANSFORMER POLE.
16. ALL POTHEADS ON PRIMARY DISTRIBUTION CABLE POLES SHALL BE FLAT DIVERGENT CAPNUT TYPE.
17. WHERE A P.L.D. WOOD POLE WITH OTHER UTILITY CONTACTS IS TO BE REMOVED THE P.L.D. INSPECTOR WILL VERIFY IF THE POLE IS IN FACT TO BE REMOVED.
18. ALL TRAFFIC STREET SIGNS SUCH AS "NO PARKING", "NO STANDING" ETC. SHALL BE TRANSFERRED FROM OLD STD. OR POLE TO NEW STD. OR POLE AT SAME LOCATION OR IN CLOSE PROXIMITY BY D.P.W. NOTIFY DAVE BRUTON AT (313) 224-1042
19. ALL TRAFFIC SIGNALS SHALL BE MOUNTED WITH NEW STANDARD TRAFFIC SIGNAL BRACKETS & FITTINGS.
20. ALL TRAFFIC SIGNAL ITEMS, AS CALLED FOR ON PLANS, SHALL INCLUDE AS INCIDENTAL TO THE TRAFFIC SIGNAL ALL CABLES FROM THE CONTROLLER TO THE TRAFFIC SIGNALS & FOUNDATIONS AS INDICATED.
21. WHEN ENTERING PROPOSED CONDUIT INTO EXISTING MANHOLES & HANDHOLES EXERCISE CAUTION NOT TO DISTURB EXISTING CABLES. FOR ENTRANCE OF CONDUITS, WALLS MUST BE CORE DRILLED UNLESS AN ALTERNATE METHOD IS APPROVED IN WRITING BY A P.L.D. INSPECTOR.

22. ALL SALVAGED TRAFFIC SIGNALS DIRECTED TO BE INSTALLED SHALL BE TRAFFIC SIGNALS PREVIOUSLY INSTALLED NEW ON THIS CONTRACT. (EXCEPT AS OTHERWISE INDICATED).
23. FOR TRAFFIC SIGNAL SPAN WIRE USE 8mm(5/16") EXTRA HIGH STRENGTH GRADE AS PER SPECIFICATIONS.
24. SIDEWALK RAMPS SHALL BE CONSTRUCTED OF THE TYPE & LOCATION AS SHOWN ON THE PLANS OR AS DIRECTED BY THE CITY ENGINEERING DEPARTMENT PAVING INSPECTORS.
25. SEAL-END OF CABLE WHERE COILING OF CABLE IS CALLED FOR ON PLANS. (CONTRACTOR SHALL RECEIVE PAYMENT FOR COILED-UP LENGTHS OF CABLE).
26. CONTRACTOR SHALL DELIVER WHERE REQUIRED TO THE PUBLIC LIGHTING DEPARTMENT THE T.S. CONTROLLER FOR TIMING. CONTRACTOR SHALL PICK-UP CONTROLLER FROM P.L.D. WHEN READY FOR INSTALLATION.
27. PROPOSED T.S. SHALL BE PUT INTO OPERATION AT TIME OF REMOVAL OF EXISTING T.S. FACILITIES. CONTRACTOR SHALL NOTIFY THE P.L.D. INSPECTOR IF HE IS UNABLE TO MAINTAIN T.S. IN AN OPERABLE CONDITION AT ALL TIMES.
28. THE CANDLEPOWER DISTRIBUTION FOR ALL MERCURY VAPOR & SODIUM VAPOR ST. LG. LUMINAIRE'S SHALL BE SEMI-CUTOFF, MEDIUM DISTRIBUTION OF TYPE AS INDICATED ON THE PLANS.
29. ALL LUMINAIRE'S SHALL BE PROVIDED WITH 240V. INTERNAL BALLASTS AS CALLED FOR ON PLANS. (EXCEPT WHERE OTHERWISE INDICATED)
30. WHERE REMOVAL OF SERIES LUMINAIRE'S IS CALLED FOR ON PLANS THE ASSOCIATED O.H. SERIES COIL SHALL BE REMOVED BY THE CONTRACTOR. (REMOVE O.H. COIL IS INCLUDED WITH THE REMOVAL OF LUMINAIRE).
31. WHERE INSTALLATION OF NEW MANHOLES OR HANDHOLES OVER EXISTING CONDUITS (TO ACCOMMODATE NEW & EXISTING CONDUITS) IS CALLED FOR ON PLANS, CONTRACTOR SHALL CAREFULLY & SO AS NOT TO DAMAGE EXIST. CABLES, REMOVE THE EXISTING CONDUITS & ENCASEMENT WITHIN HOLES. EXIST. CABLES SHALL BE PROPERLY TRAINED, RACKED & SUPPORTED.
32. WHERE ABANDONING OF U.G. CABLES IS CALLED FOR ON PLANS OR DIAGRAMS, CONTRACTOR SHALL CUT & REMOVE CABLES WITHIN MANHOLES & HANDHOLES.
33. FOR LOCATIONS OF P.L.D. INSTALLATIONS ON STRUCTURES SUCH AS CONDUITS HANDHOLES, CONDUIT SLEEVES, GALVANIZED STEEL CONDUITS & ANCHOR BOLTS FOR STREET LIGHTING STANDARDS SEE STRUCTURE PLANS AND P.L.D. DETAIL SPECIFICATIONS
34. PAVEMENT, SIDEWALK, CURB REMOVAL, REPLACEMENT AND EXCAVATION & BACKFILL SHALL BE DONE ACCORDING TO CITY OF DETROIT CITY ENGINEERING DIVISION STANDARD SPECIFICATIONS PAVING AND RELATED CONSTRUCTION.
35. UNDERGROUND CABLE QUANTITIES ARE ITEMIZED ON GENERAL PLANS. ALL PERTINENT CABLES SHALL BE TAGGED IN ALL M.H.'S & H.H.'S. THIS INCLUDES EXIST. CABLES THAT ARE CONVERTED TO MULTIPLE, RECONNECTED TO OTHER CIRCUITS OR RENDERED DEAD.
36. ALL SALVAGED & CONVERTED STEEL STREET LIGHTING STANDARDS SHALL BE PAINTED.
37. ALL ST. LG. UNITS INSTALLED ON THIS CONTRACT AND EXIST. STREET LIGHTING UNITS CONVERTED OR RE-CONNECTED TO OTHER CIRCUITS SHALL BE STENCILED OR RE-STENCILED AS SHOWN NO PLANS. (INCLUDED WITH STREET LIGHTING UNITS)
38. STENCILING SHALL BE ON THE CURB SIDE OF THE POLE, LOCATED BETWEEN 1.219m(4') AND 1.524m(5') ABOVE GRADE. ALL LETTERS AND NUMBERS SHALL BE 50.8mm(2") IN HEIGHT. THE STENCILING SHALL BE DONE WITH A WEATHER-RESISTANT ENAMEL: BLACK ENAMEL ON GRAY COLORED OR ALUMINUM POLES, AND YELLOW OR WHITE ENAMEL ON BLACK OR BRONZE COLORED POLES.

39. WHERE UNDERGROUND UTILITIES INTERFERE WITH THE INSTALLATION OF A NEW FOUNDATION, INSTALL THE SPECIAL FOUNDATION OF PARTICULAR DIMENSIONS AS INDICATED ON THE DETAIL DRWG. TO SUIT THE FIELD CONDITION. THERE WILL BE NO EXTRA PAYMENT FOR THE SPECIAL FOUNDATION. IT WILL BE PAID FOR AS A NORMAL FOUNDATION.
40. ALL NEW CONDUIT RUNS SHALL BE BUILT STRAIGHT, AS POSSIBLE. BENDS SHALL HAVE NO LESS THAN 7.925m(26') RADIUS AND NO REVERSE OR "S" BENDS.
41. WHERE TRIMMING OF TREES ON CITY PROPERTY IS CALLED FOR ON PLANS THE CONTRACTOR SHALL OBTAIN A PERMIT FROM THE RECREATION DEPT. OF THE CITY OF DETROIT AND SHALL HAVE SUCH WORK DONE BY A LICENSED TREE SERVICE CONTRACTOR. CALL (313) (224-1111).
42. ALL TREE TRIMMING REQUIRED TO CLEAR NEW OR SALVAGED STREET LIGHTING & TRAFFIC SIGNAL STD.'S AND O.H. ST. LG. & TRAFFIC SIGNAL UNITS & O.H. WIRES SHALL BE INCLUDED WITH THE PAY ITEM & NO EXTRA PAYMENT SHALL BE MADE.
43. WHERE IT IS SHOWN ON PLANS TO HAND DIG FOUNDATION, EXCAVATE BY HAND TOOLS ENTIRE DEPTH OF FOUNDATION. NO MECHANICAL EQUIPMENT SHALL BE USED.
44. CONTRACTOR SHALL NOTIFY THE P.L.D. SYSTEM OPERATOR AT (313) (961-1364) & THE TRAFFIC ENGINEERING DIVISION OF D.P.W. AT (313) 628-5603 AFTER COMPLETION OF WORK AT ANY TRAFFIC SIGNAL INTERSECTION.
45. ALL CABLES SHALL BE TRAINED & PROPERLY RACKED IN ALL EXISTING MANHOLES & HANDHOLE. RACKS ARE TO BE INSTALLED WHERE NECESSARY & ARE INCLUDED IN THE INSTALLATION OF UNDERGROUND CABLE.
46. ALL CONDUITS STUBED OUT OF STRUCTURES SUCH AS MANHOLES, HANDHOLES OR FOUNDATION SHALL EXTEND 0.914m(3') BEYOND PAVEMENT LIMIT (EXCEPT AS OTHERWISE INDICATED). ALL UNOCCUPIED CONDUITS SHALL BE PLUGGED WITH PLASTIC TAPERED PLUGS SIZED TO MATCH THE CONDUIT (CARLAN P258T OR EQUAL).
47. ALL NEW UNDERGROUND-FED STREET LIGHTING UNITS SHALL BE INSTALLED WITH CENTER 0.915m(3.0') BACK OF FACE OF CURB UNLESS OTHERWISE INDICATED ON PLANS. VERIFY WITH P.L.D.
48. D.S.R. STREETCAR RAILS AND FOUNDATIONS (TRACKS) ARE SHOWN ON THE PLANS IN ACCORDANCE WITH THE BEST AVAILABLE INFORMATION. EXACT LOCATIONS WITHIN THE STREETS & INTERSECTIONS ARE NOT KNOWN. SOME RAILS MAY ALREADY BE REMOVED.
49. THE "FINAL" CONDUIT MUST BE TRIMMED FLUSH WITH MANHOLE WALL AND HAVE END BELLS, SPACERS AND BE TUCK POINTED. DO NOT ENCASE FINAL CONDUIT WITHOUT INSPECTION BY THE P.L.D. UNDERGROUND INSPECTION DEPARTMENT.
50. INSTALL 5mm(3/16") DIAMETER YELLOW POLYPROPYLENE ROPE IN ALL "FINAL" CONDUIT. (INCLUDE IN PAY ITEM FOR "CONDUIT")
51. METRIC MEASUREMENTS: M-METERS, mm-MILLIMETERS AND MPa-MEGAPASCALS.
52. CONDUIT TRENCHES SHALL BE EXCAVATED FROM MANHOLE TO MANHOLE TO ASSURE A CLEAR PASSAGE WITH PROPER GRADING PRIOR TO BUILDING ENCASED CONDUIT RUN.

ITEM	LIST OF MATERIAL	QUANTITIES
CONDUIT REPAIR-UNDER SIDEWALK OR DIRT	EA
CONDUIT REPAIR-UNDER PAVEMENT	EA
REMOVING STREETCAR RAIL AND FOUNDATION	M

THE ITEMS AND QUANTITIES LISTED ABOVE SHALL APPLY TO ALL LOCATIONS AS DIRECTED BY THE ENGINEER.

ALL REMOVED TRAFFIC SIGNAL AND STREET LIGHTING EQUIPMENT SHALL BE SALVAGED IN REUSABLE CONDITION AND SHALL BECOME PROPERTY OF PLD. ALL REMOVED MATERIAL WILL BE STORED ON SITE FOR PICK-UP BY PLD. ALL MATERIAL LEFT FOR THE CONTRACTOR WILL BECOME THE RESPONSIBILITY OF THE CONTRACTOR FOR DISPOSAL AWAY FROM THE SITE.

HAND DIG ENTIRE DEPTH OF ALL STEEL STRAIN POLE & MAST ARM STANDARD FOUNDATIONS.

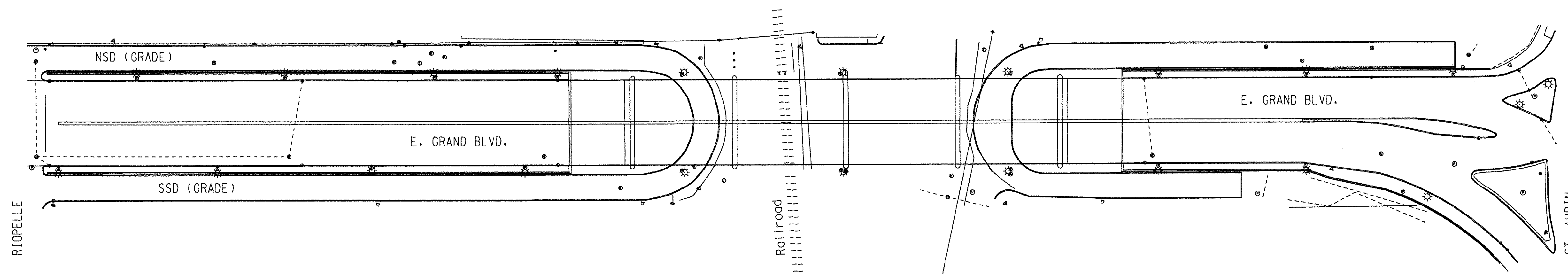

AREA MAP
N.T.S.



REVISIONS	Date	Description	Chkd. by

IMPROVEMENT OF STREET LIGHTING
EAST GRAND BOULEVARD BRIDGE
GENERAL PLAN

Designed by C.E.A.	Consulting Engineering Associates, Inc. <small>16580 WYOMING AVE. DETROIT MICHIGAN 48221 TELEPHONE: (313) 341-5797 FAX: 341-0205</small>	Scale	PUBLIC LIGHTING DEPARTMENT <small>CITY OF DETROIT</small>	File No. 51-0686
Drawn by ---	Disk File Name RR-CN	Checked by	Job File No. CEA 138200	Sheet No. 40 of 60
Checked by ---	Job File No.	Approved by	Date	3-03-08

DATE PLOTTED: 03/03/08

Computer File: Pen Table File

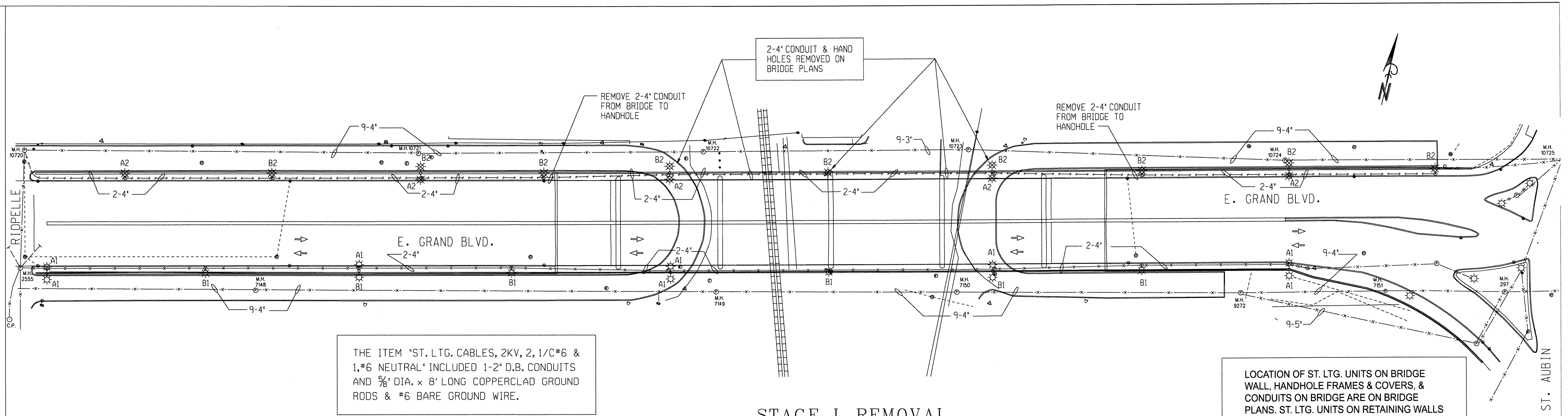

THE ITEM "ST. LTG. CABLES, 2KV, 2, 1/C#6 & 1,#6 NEUTRAL" INCLUDED 1-2" D.B. CONDUITS AND 5/8" DIA. x 8' LONG COPPERCLAD GROUND RODS & #6 BARE GROUND WIRE.

LOCATION OF ST. LTG. UNITS ON BRIDGE WALL, HANDHOLE FRAMES & COVERS, & CONDUITS ON BRIDGE ARE ON BRIDGE PLANS. ST. LTG. UNITS ON RETAINING WALLS ARE ON RETAINING WALL PLANS. REBUILD ALL EXISTING HANDHOLES. EXTEND 1-3" E.C. FROM HANDHOLE TO MEET SWEEPS IN RETAINING WALL.

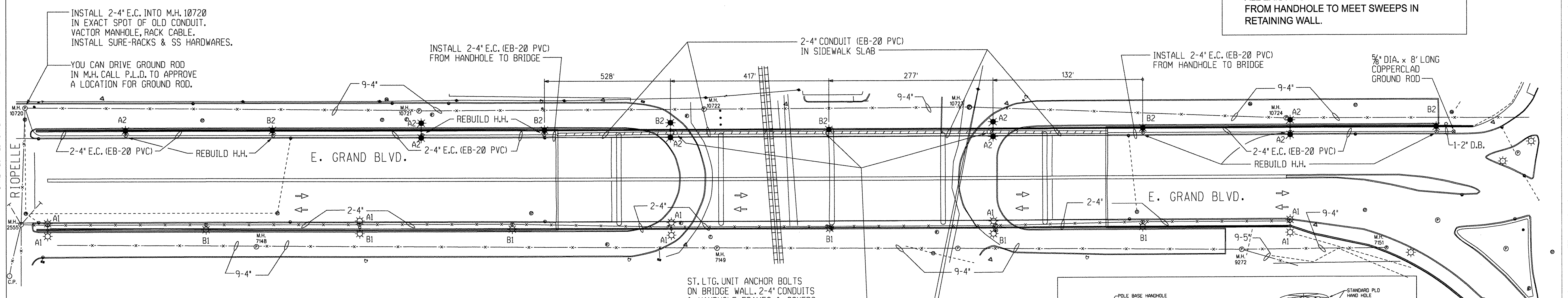

ST. LTG. UNIT ANCHOR BOLTS ON BRIDGE WALL. 2-4" CONDUITS & HANDHOLE FRAMES & COVERS IN SIDEWALK SLAB ON BRIDGE PLANS

1-3" CONDUIT FROM HANDHOLE TO LTG. UNIT

SEE DETAIL "A" THIS SHEET (TYP.)

LIST OF MATERIAL ITEMS	UNIT	QUANTITIES		
		SHEET NO. 3	4	TOTAL
Underground Fed St Ltg Unit, Rem	ea	10	9	19
Cable, Rem	ft	1280	1150	2430
Conduit, Rem	ft	820	700	1520
Hh, Rebuild	ea	7	6	13
Luminaire, 250W, 240V. Sodium Vapor	ea	14	14	28
Code 009-00 Anchor Base St. Ltg. Standard	ea	10	9	19
Bracket Arm, Clamp-on, 6 Foot, 3 Foot Rise	ea	14	14	28
Conduit, Encased, 1,3"	ft	50	50	100
Conduit, Encased, 2,4"	ft	820	700	1520
St Ltg Cable, 2Kv, 1, 1/c#6 & 1, #6 Neutral	ft	140	140	280
St Ltg Cable, 2Kv, 2, 1/c#6 & 1, #6 Neutral	ft	1150	1000	2250

STAGE I INSTALLATION

PLAN
SCALE: 1"=40'

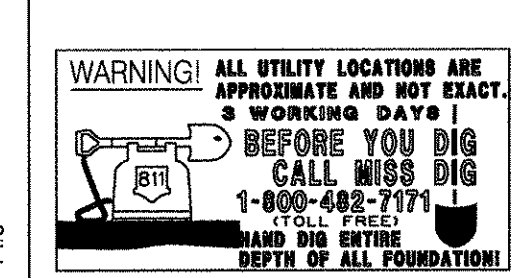
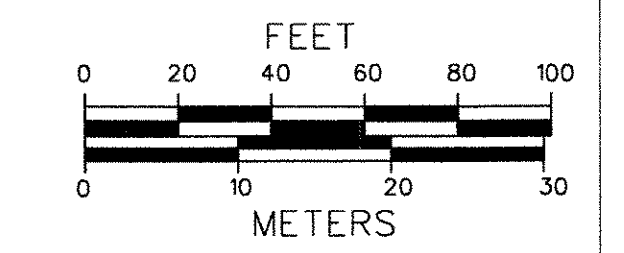
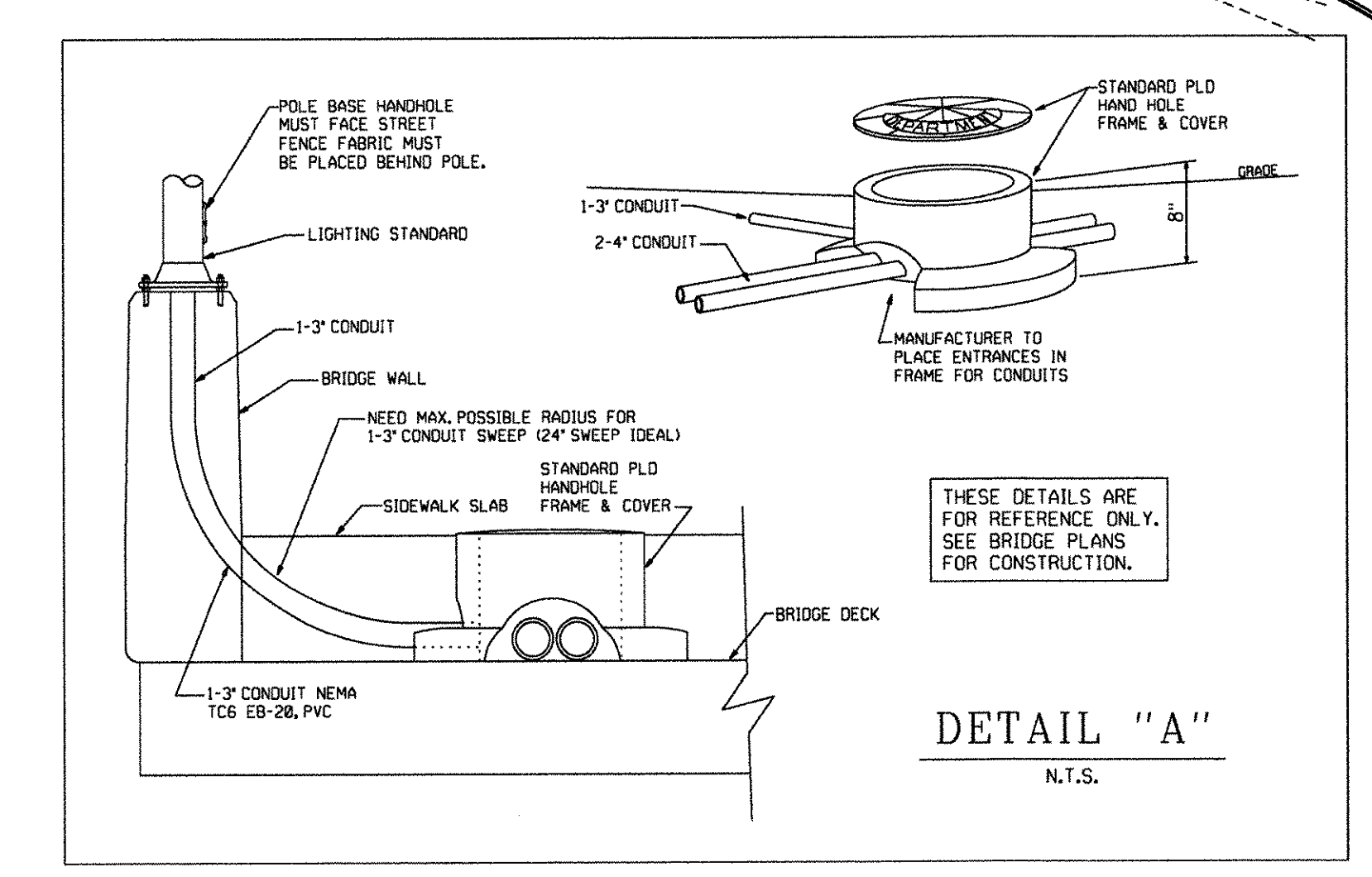

Date	Description	Chkd. by

IMPROVEMENT OF STREET LIGHTING
EAST GRAND BOULEVARD BRIDGE
GENERAL PLAN

Designed by C.E.A.	<p>Consulting Engineering Associates, Inc. 16580 WYOMING AVE. DETROIT MICHIGAN 48221 TELEPHONE: (313) 341-5797 FAX: 341-0205</p>	Scale 40	<p>PUBLIC LIGHTING DEPARTMENT CITY OF DETROIT</p>	File No. 51-0686
Drawn by		Checked by		Sheet No. 41 of 60
Checked by		Approved by		Date 3-03-08

	Disk File Name RR-3	Job File No. CEA 138200
--	------------------------	----------------------------

--	--	--

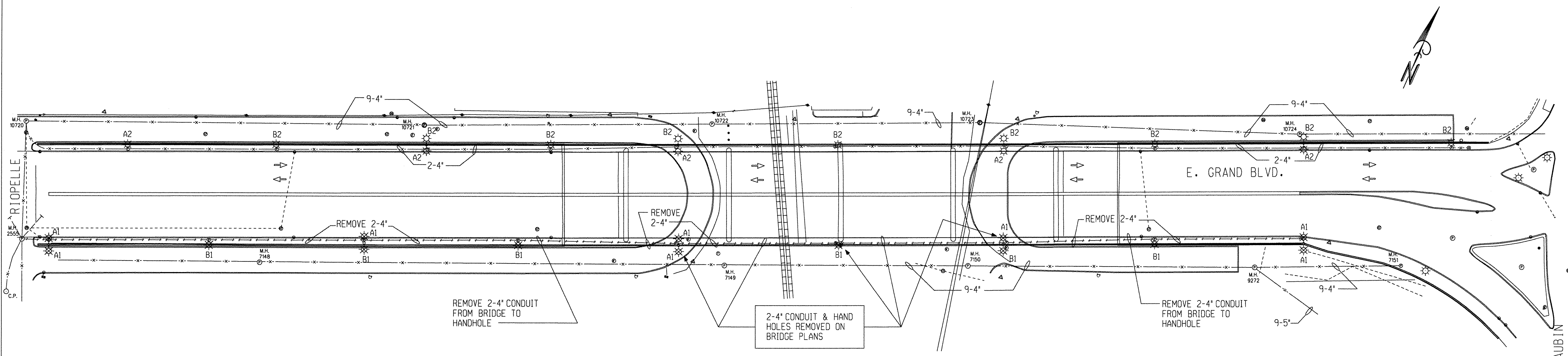

STAGE II REMOVAL

THE ITEM "ST. LTG. CABLES, 2KV, 2, 1/C#6 & 1,#6 NEUTRAL" INCLUDED 1-2" D.B. CONDUITS AND 5/8" DIA. x 8' LONG COPPERCLAD GROUND RODS & #6 BARE GROUND WIRE.

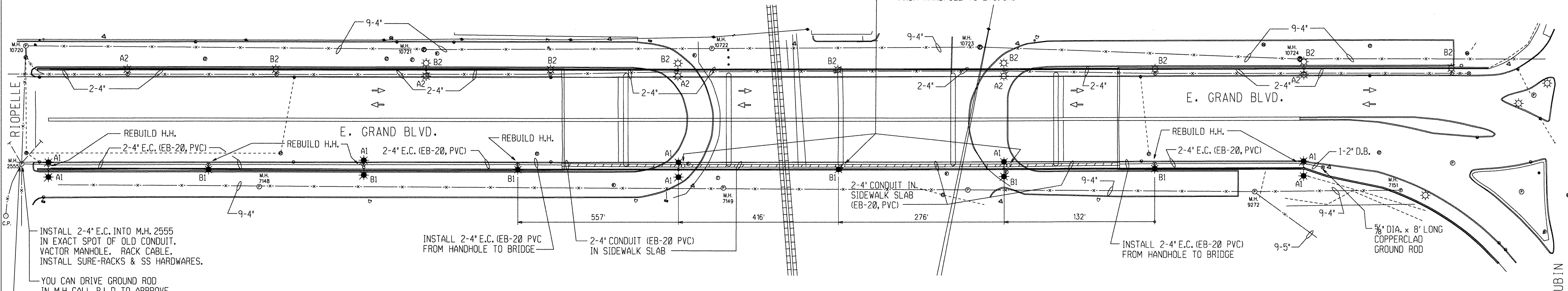

STAGE II INSTALLATION

LOCATION OF ST. LTG. UNITS ON BRIDGE WALL, HANDHOLE FRAMES & COVERS, & CONDUITS ON BRIDGE ARE ON BRIDGE PLANS. ST. LTG. UNITS ON RETAINING WALLS ARE ON RETAINING WALL PLANS. REBUILD ALL EXISTING HANDHOLES. EXTEND 1-3" E.C. FROM HANDHOLE TO MEET SWEEPS IN RETAINING WALL.

PLAN
SCALE: 1"=40'

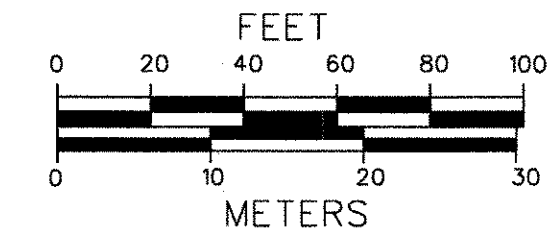

Date	Description	Chkd. by

IMPROVEMENT OF STREET LIGHTING
EAST GRAND BOULEVARD BRIDGE
GENERAL PLAN

Designed by C.E.A.
Drawn by ---
Checked by ---

Consulting Engineering Associates, Inc.
16580 WYOMING AVE. DETROIT MICHIGAN 48221
TELEPHONE: (313) 341-5797 FAX: 341-0205

Disk File Name: RR-4
Job File No.: CEA 138200

Scale 40
Checked by ---
Approved by ---

PUBLIC LIGHTING DEPARTMENT
CITY OF DETROIT

File No. 51-0686
Sheet No. 42 of 60
Date 3-03-08

Computer File: Pen, Table File

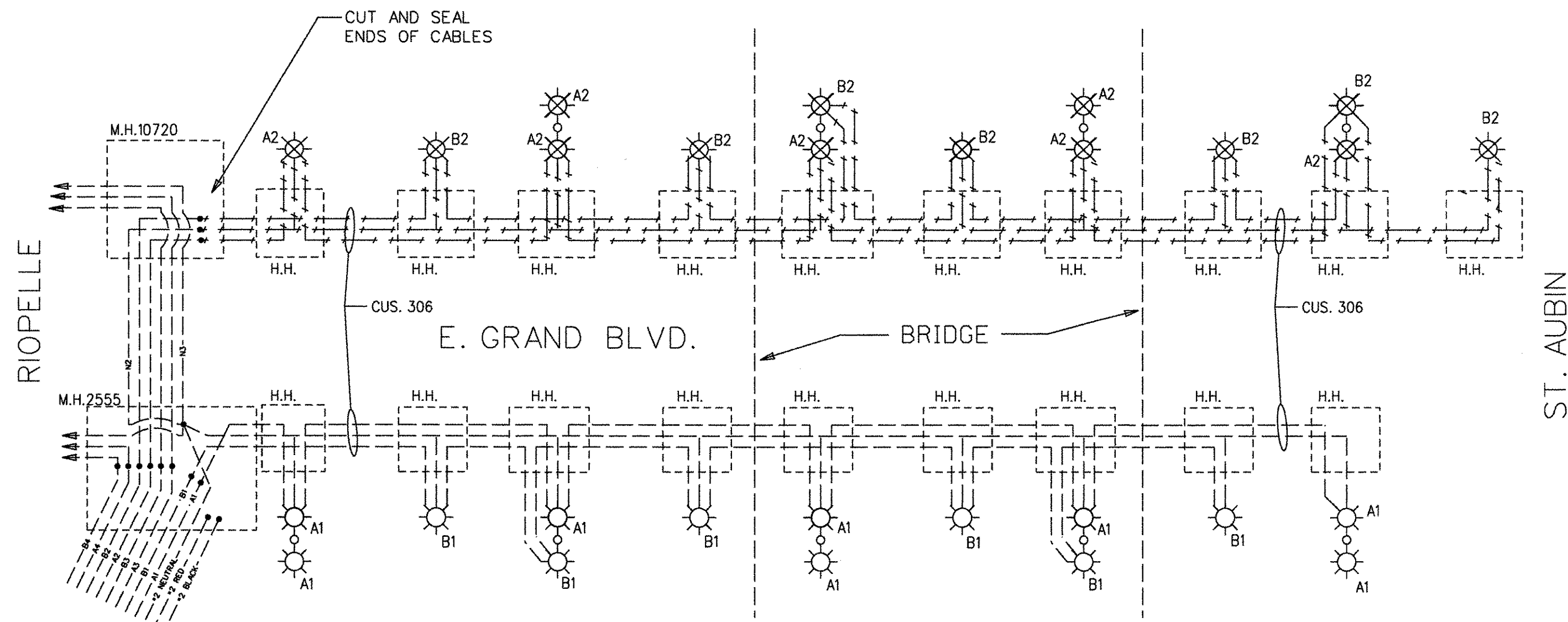

MULT. ST. LTG. DIAGRAM
STAGE I REMOVAL
240/480V.

CUSTER 306
240/480V.

THE ITEM "ST. LTG. CABLES, 2KV, 6, 1/C#6 & 1,#6 NEUTRAL" INCLUDED 1-2" D.B. CONDUITS AND 5/8" DIA. x 8' LONG COPPERCLAD GROUND RODS & #6 BARE GROUND WIRE.

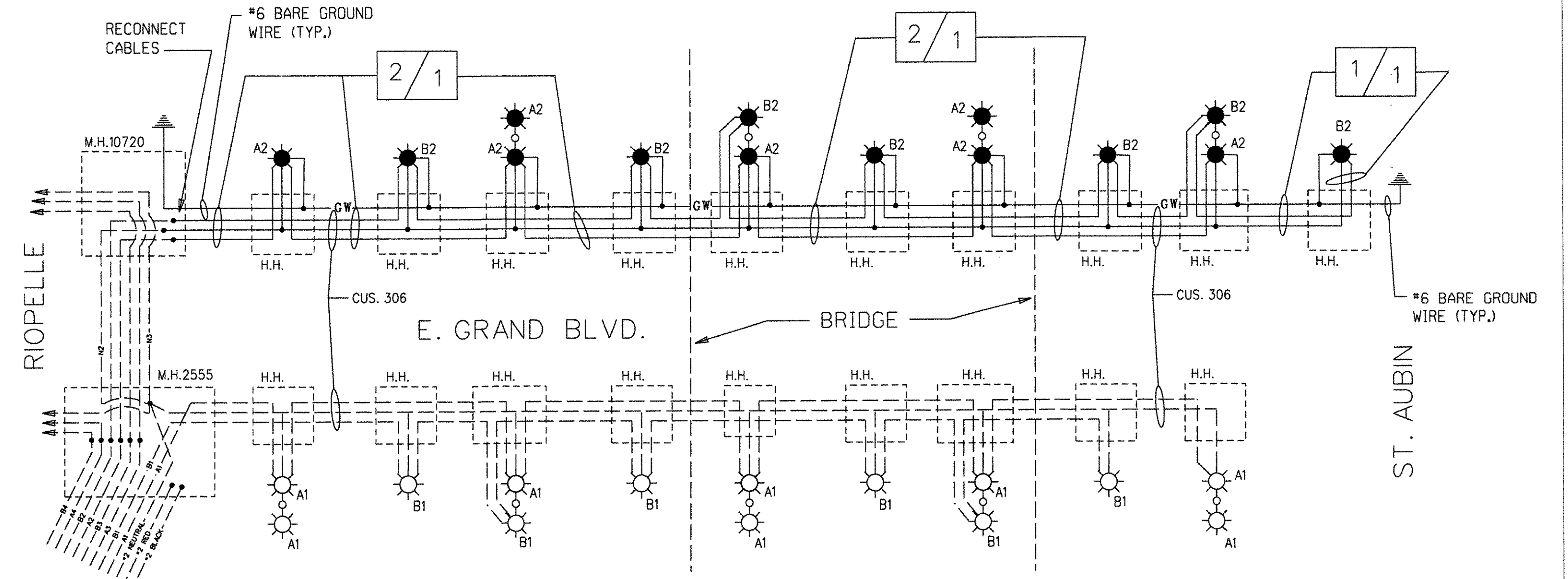

MULT. ST. LTG. DIAGRAM
STAGE I INSTALLATION
240/480V.

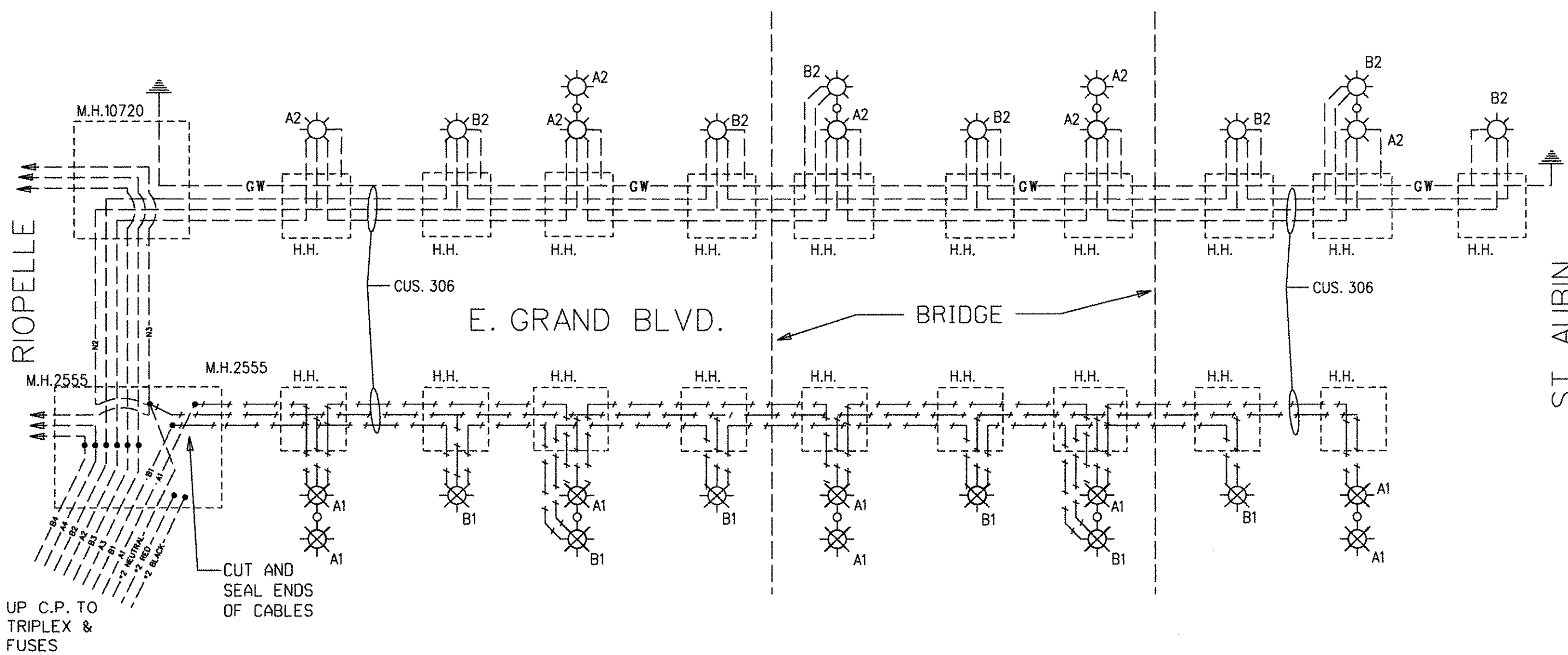

MULT. ST. LTG. DIAGRAM
STAGE II REMOVAL
240/480V.

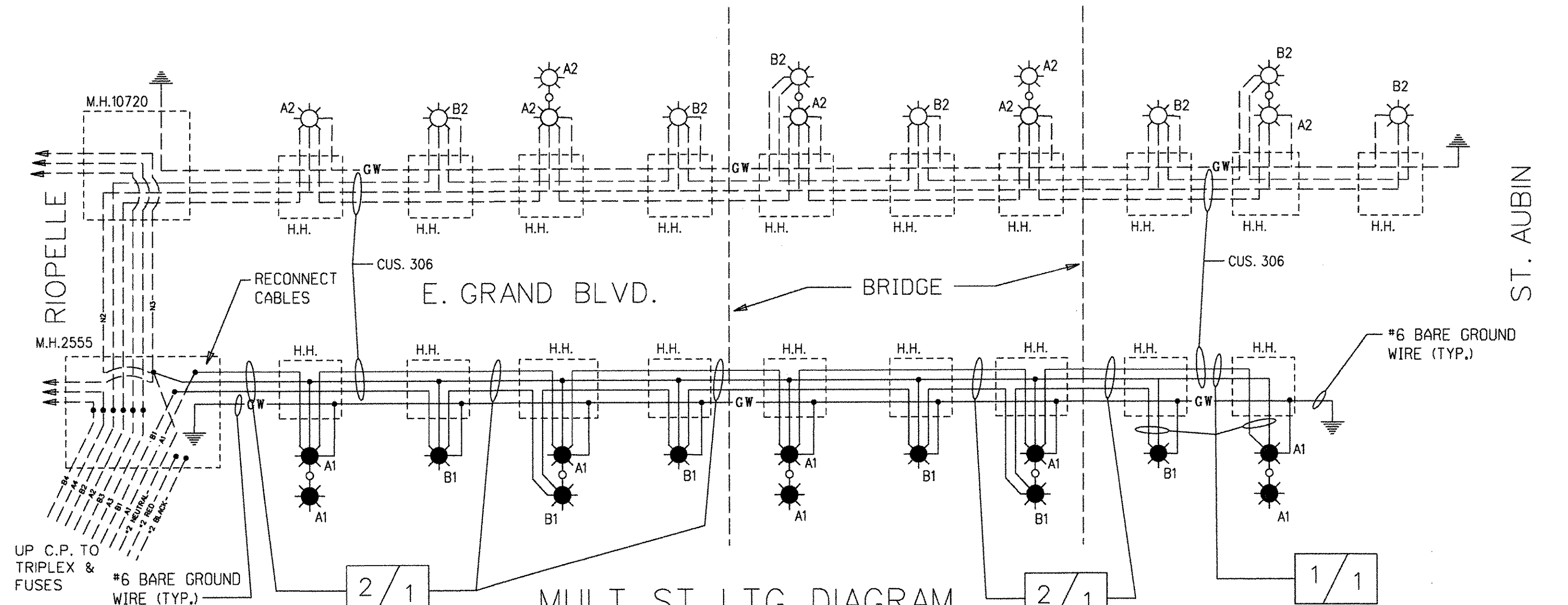

MULT. ST. LTG. DIAGRAM
STAGE II INSTALLATION
240/480V.



REV.	Date	Description	Chkd. by

IMPROVEMENT OF STREET LIGHTING
EAST GRAND BOULEVARD BRIDGE
WIRING DIAGRAMS

Designed by
C.E.A.
Drawn by

Checked by

Consulting
Engineering
Associates, Inc.
16580 WYOMING AVE. DETROIT MICHIGAN 48221
TELEPHONE: (313) 341-5797 FAX: 341-0205

Scale
Checked by
Approved by

PUBLIC LIGHTING
DEPARTMENT
CITY OF DETROIT

File No.
51-0686
Sheet No.
43 of 60
Date
3-03-08

REVISION DATE: APRIL 1, 2001
 Computer File: T:\138200 E. Grand Blvd Bridge\DETAILS\101plde.dgn
 DATE PLOTTED: 3/20/2008
 TIME: 2:40:46 PM

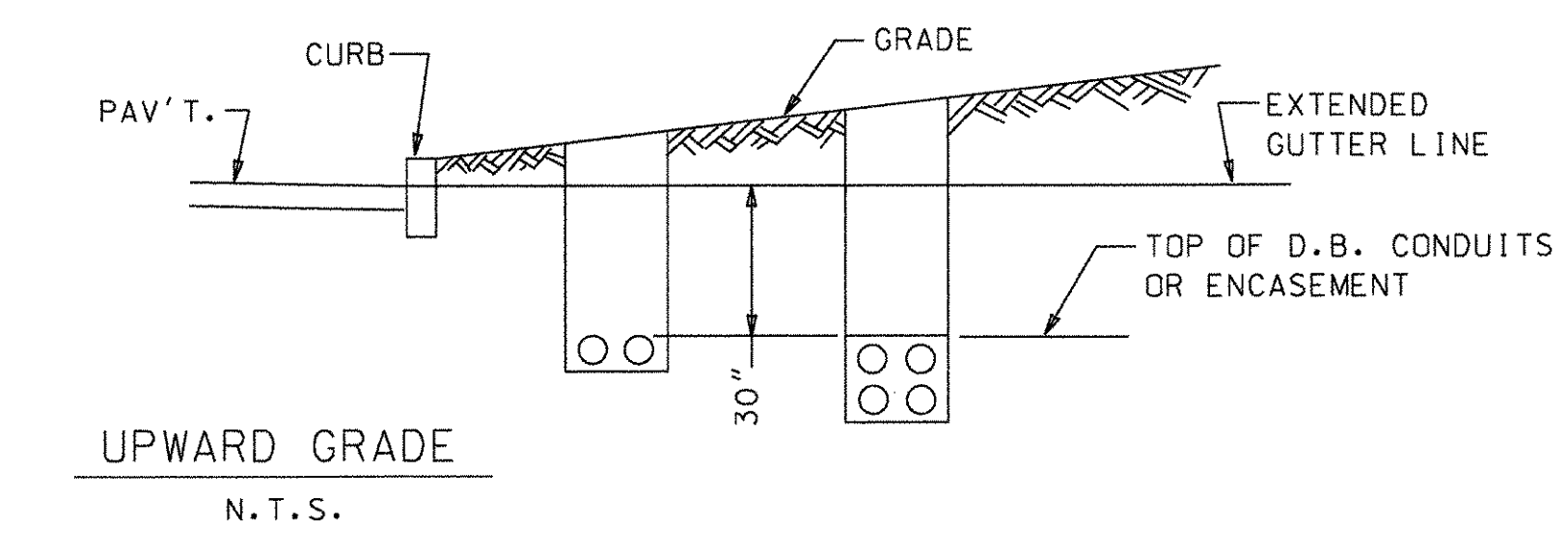
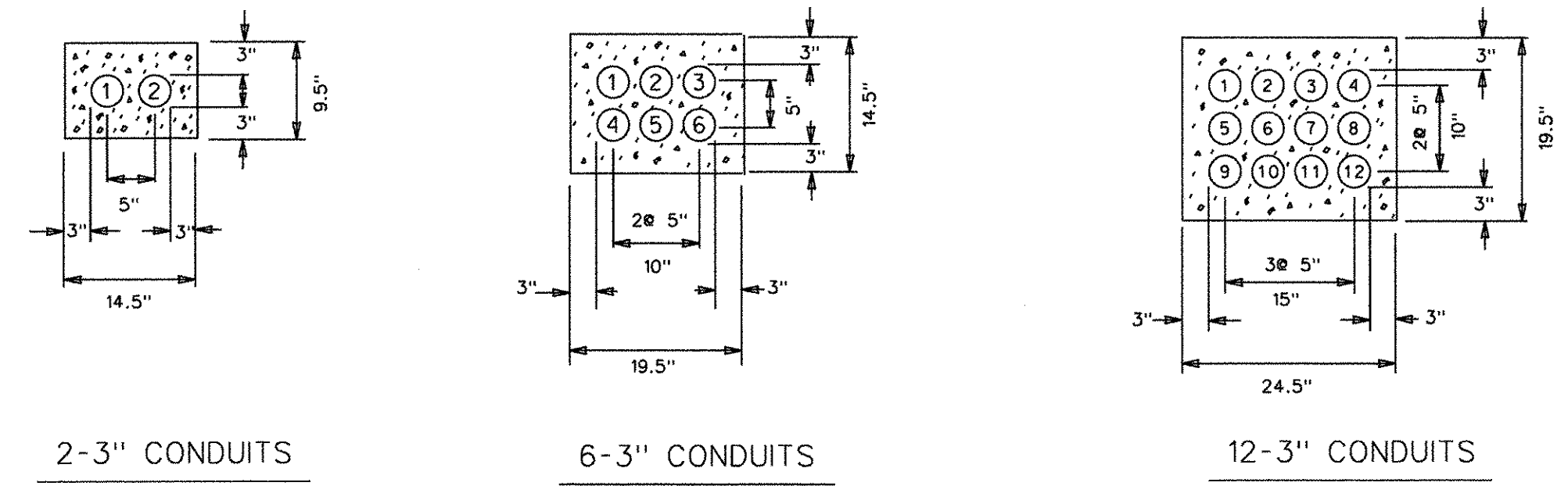
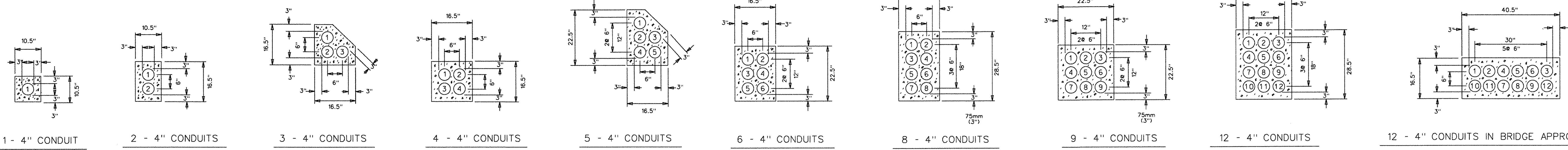
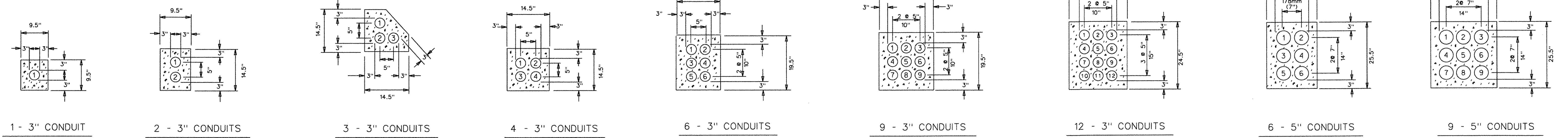
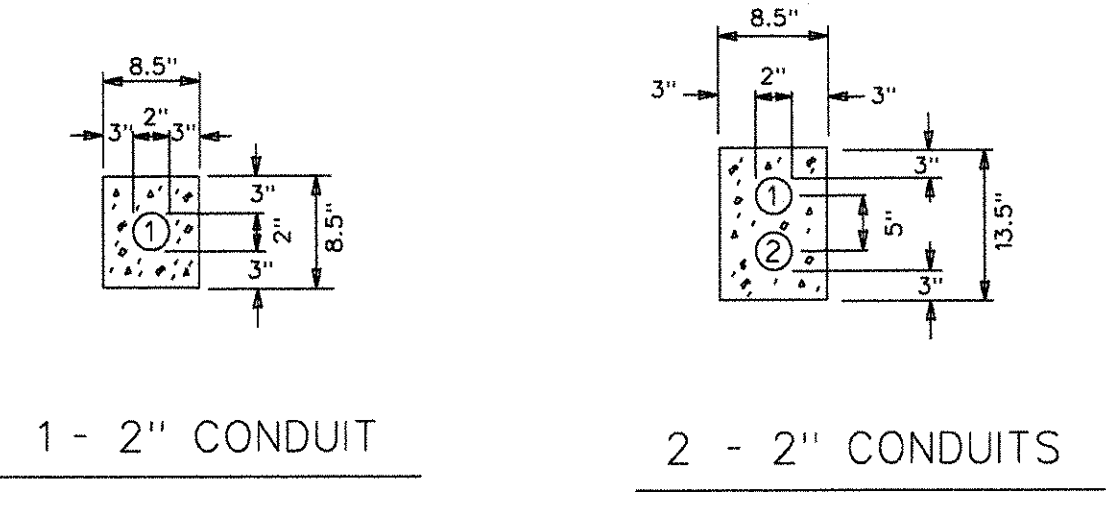

ALTERNATE ARRANGEMENT OF 3" CONDUIT
(TO SUIT FIELD CONDITIONS)
(TO BE APPROVED BY THE ENGINEER)

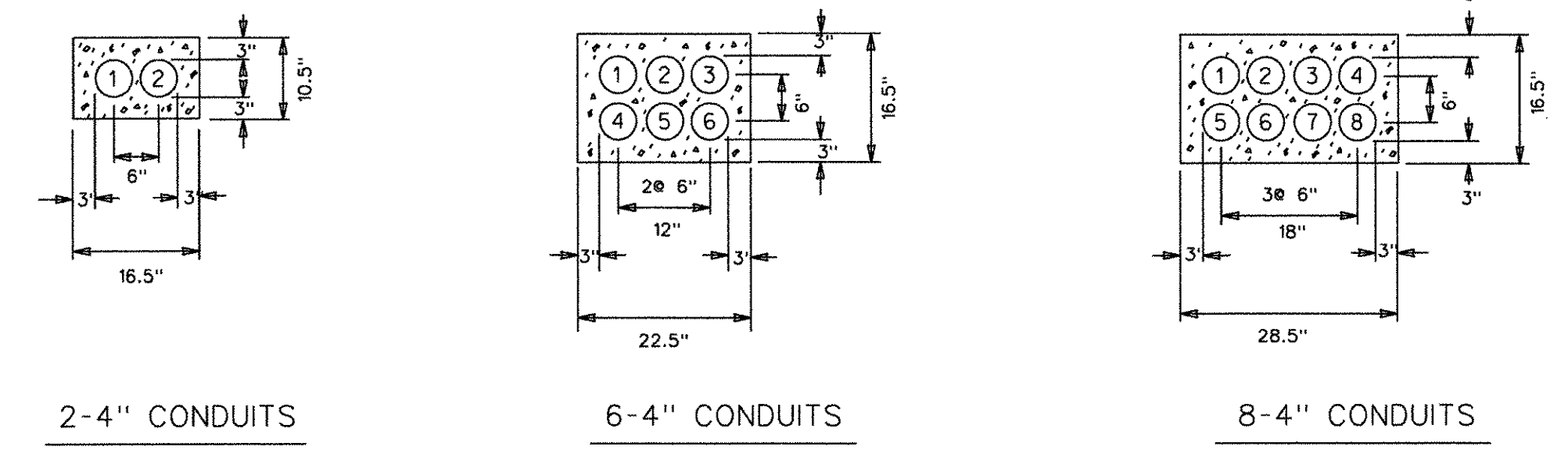

ALTERNATE ARRANGEMENT OF 100mm (4") CONDUIT
(TO SUIT FIELD CONDITIONS)
(TO BE APPROVED BY THE ENGINEER)

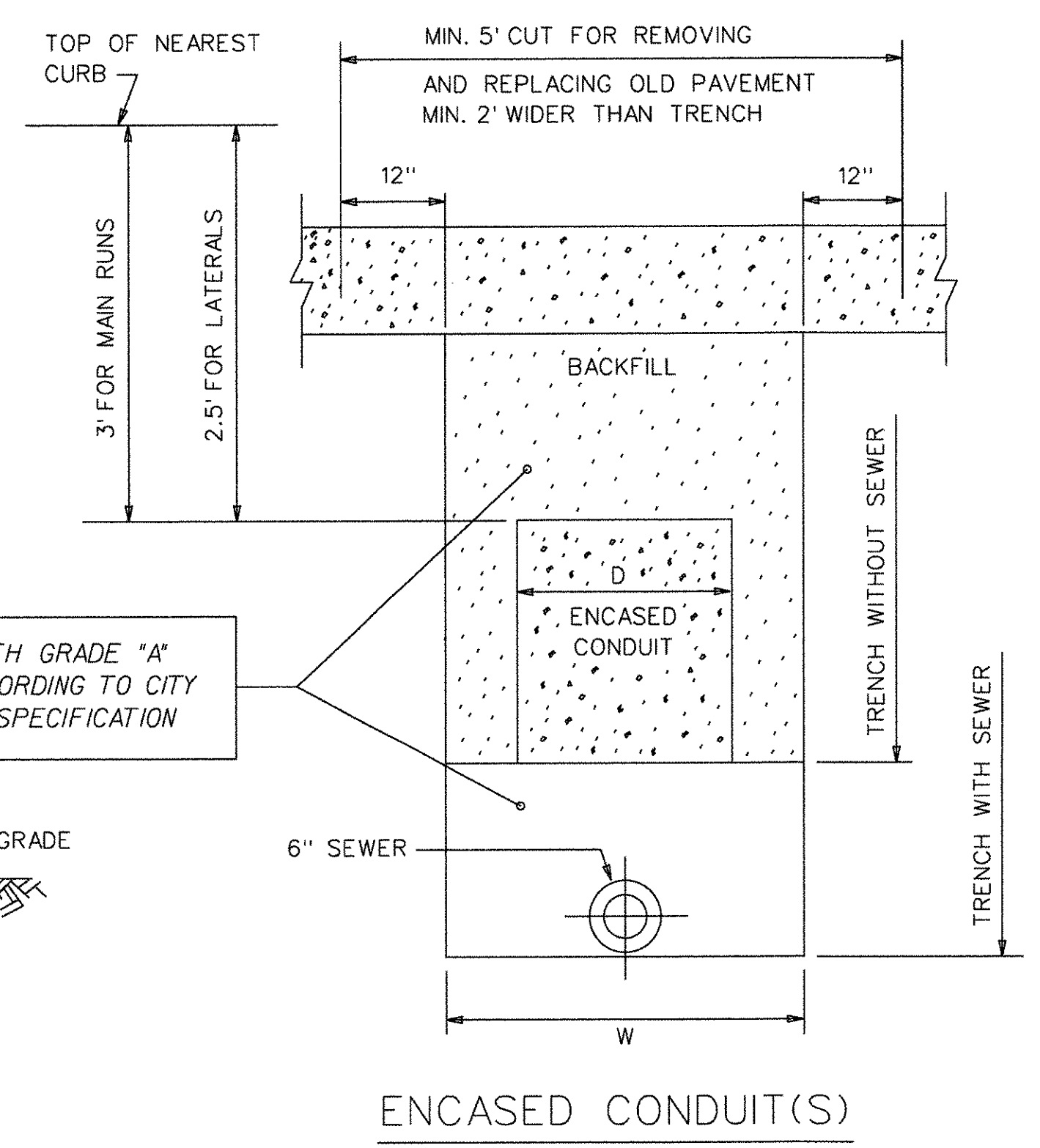
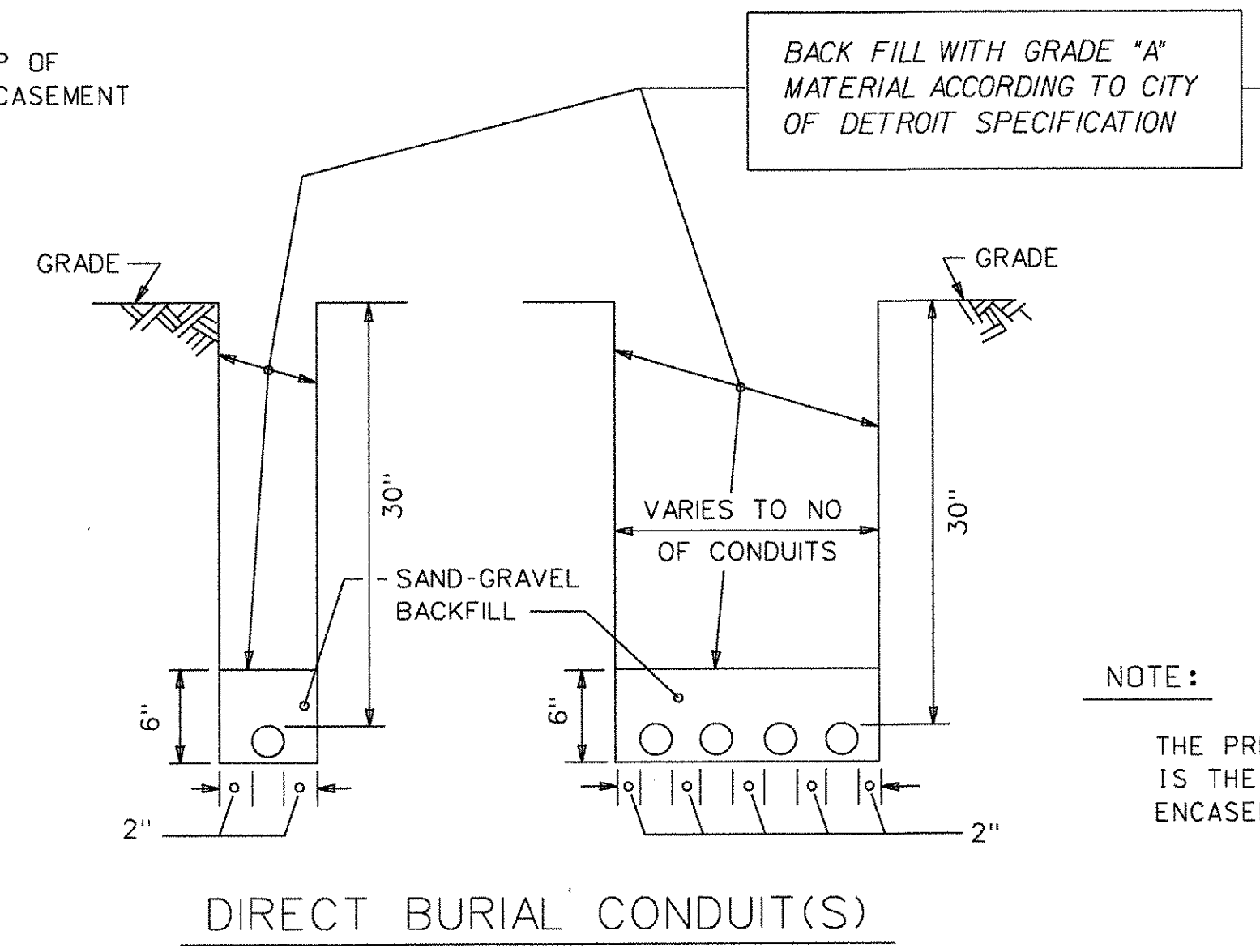

NOTE:
THE PREFERRED TRENCH WIDTH "W" IS THE WIDTH OF "D" OF CONDUIT ENCASEMENT.

SCALE: AS SHOWN

REVISIONS		
Date	Description	Chkd. by

DETAILS
EAST GRAND BOULEVARD BRIDGE
MISCELLANEOUS CONDUIT SECTIONS

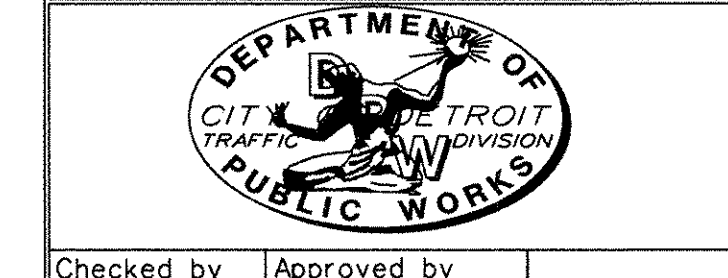

Checked by	Approved by	File No.
		51-0686

Consulting Engineering Associates, Inc.
 16580 WYOMING AVE, DETROIT MICHIGAN 48221
 TELEPHONE: (313) 341-5797 FAX: 341-0205
 Designed by C.E.A. Checked by C.E.A. Sheet No. 44 of 90
 Disk File Name: 101PLDE Job File No. CEA 138200
 Date: 3-03-08 Dwg. No. DTL-5-

101E

REVISION DATE: APRIL 1, 2001
 Computer File: T:\138200 E. Grand Blvd Bridge\DETAILS\103plde.dgn
 DATE PLOTTED: 3/20/2008
 TIME: 2:41:21 PM

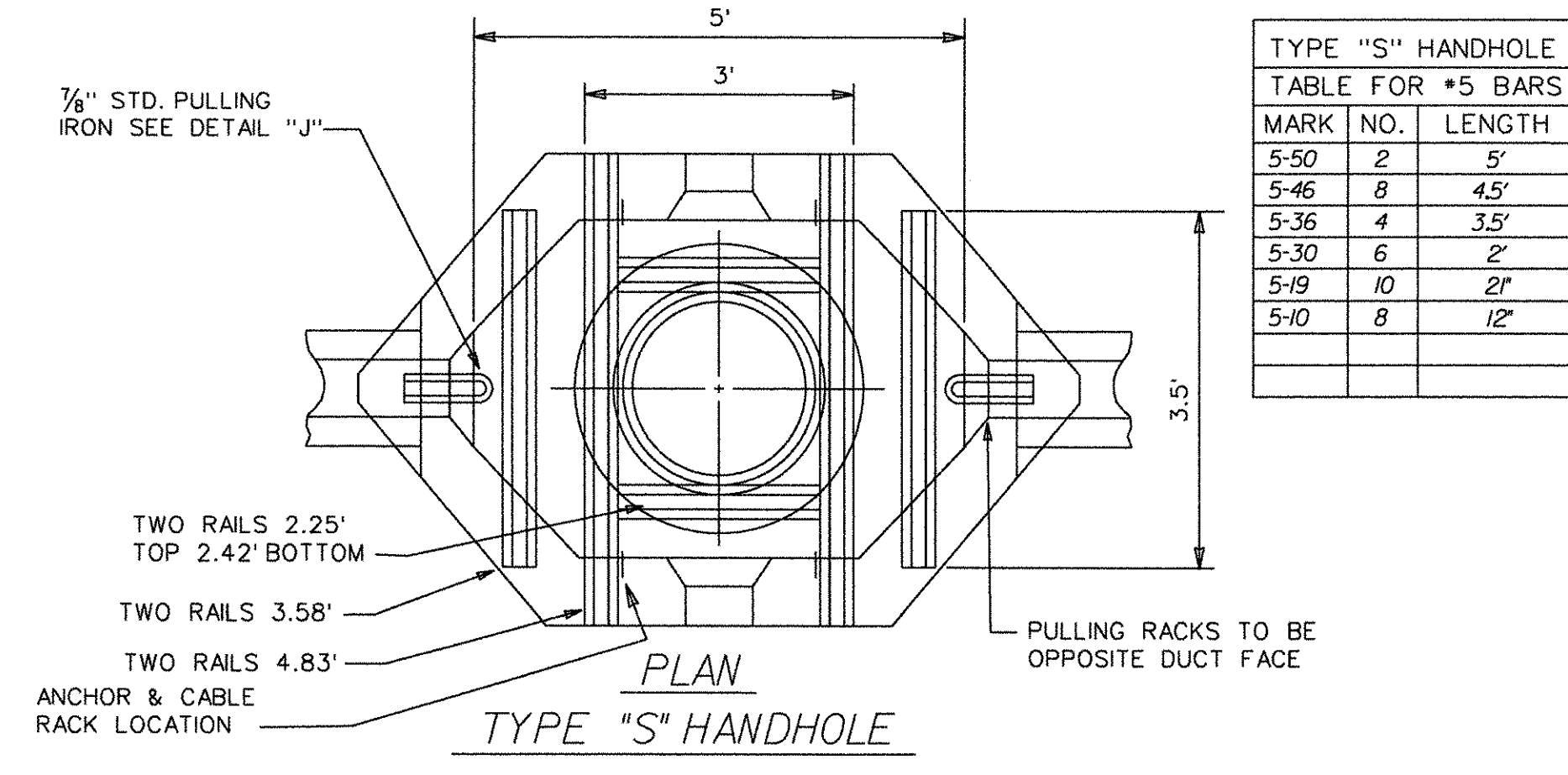

TYPE "S" HANDHOLE		
MARK	NO.	LENGTH
5-50	2	5'
5-46	8	4.5'
5-36	4	3.5'
5-30	6	2'
5-19	10	2'
5-10	8	12"

TYPE "D" HANDHOLE		
MARK	NO.	LENGTH
4-46	3	5'
4-40	4	48"
4-39	4	45"
4-36	4	42"
4-30	3	36"
4-16	1	18"
4-13	8	15"
4-10	4	12"

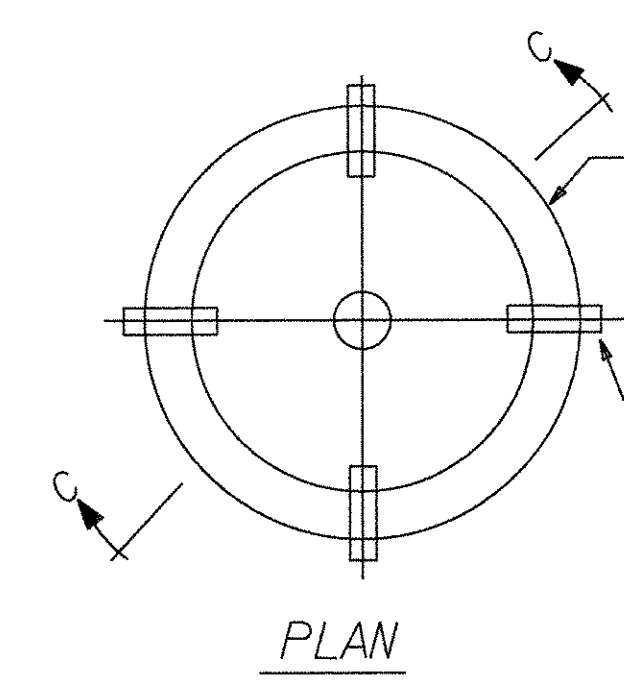
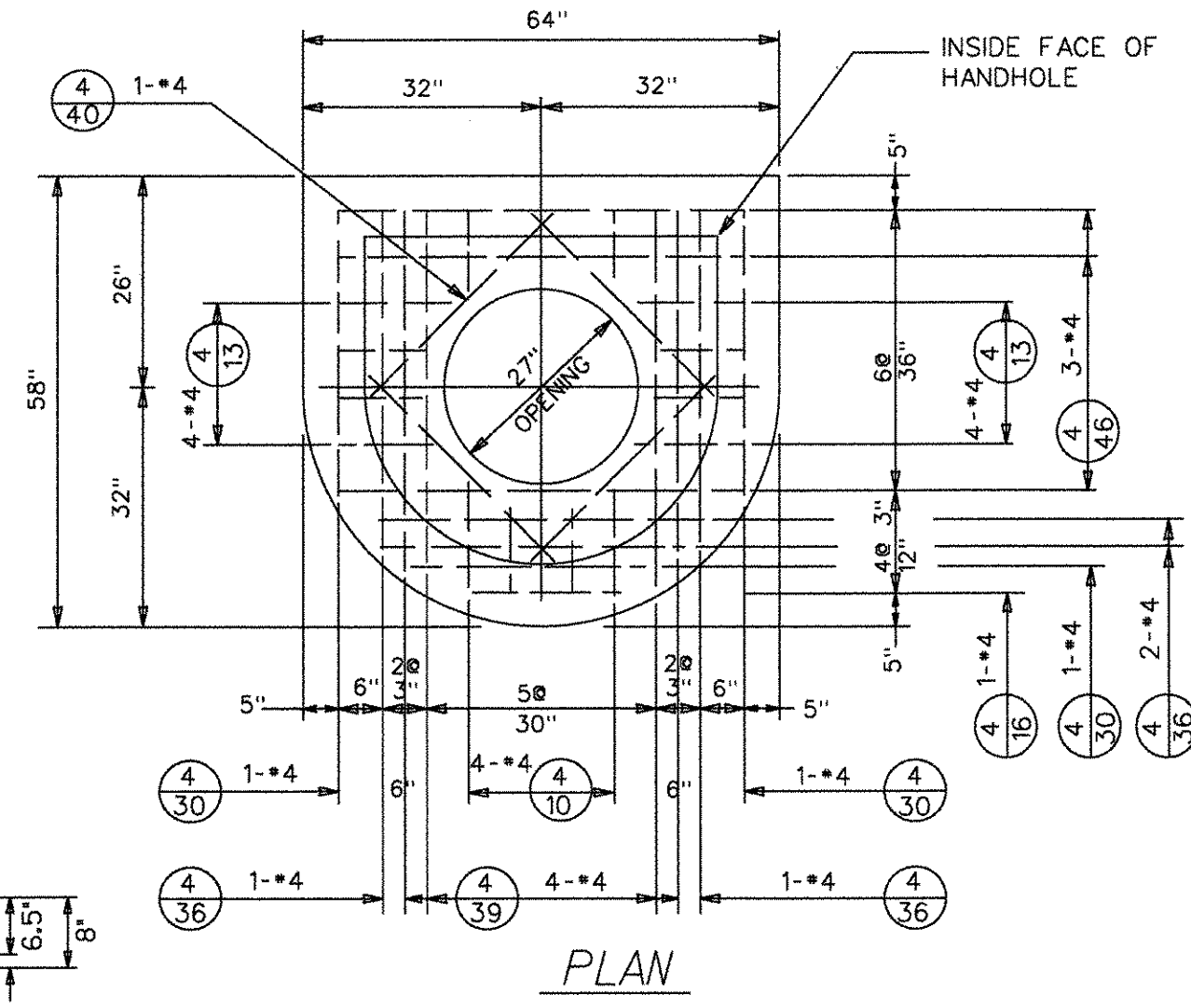

NOTE:
BELL ENDS ARE REQUIRED ON EACH CONDUIT BROKEN OUT IN HANDHOLE. TYPE AND SIZE SHALL BE IDENTICAL TO CONDUIT TYPE AND SIZE.

NOTE:
1. FRAMES MAY BE A.S.T.M. CLASS 30 GRAY IRON IF THE CONTRACTOR SO ELECTS.
2. ALL FILLETS ARE .5" RADIUS & ALL ROUNDS ARE .25" RADIUS

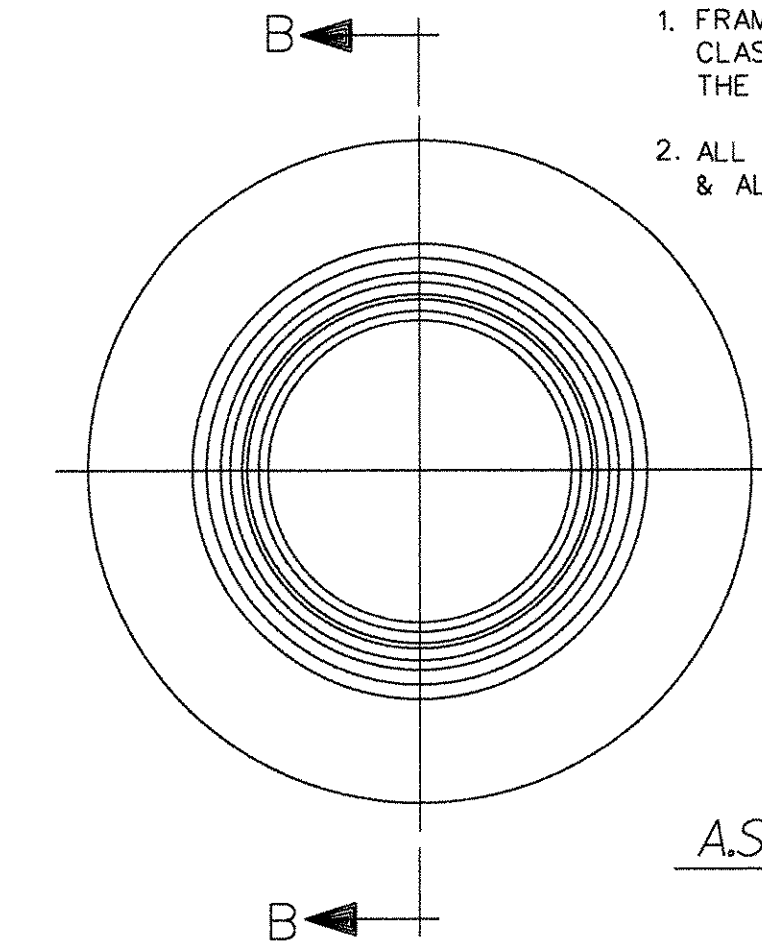
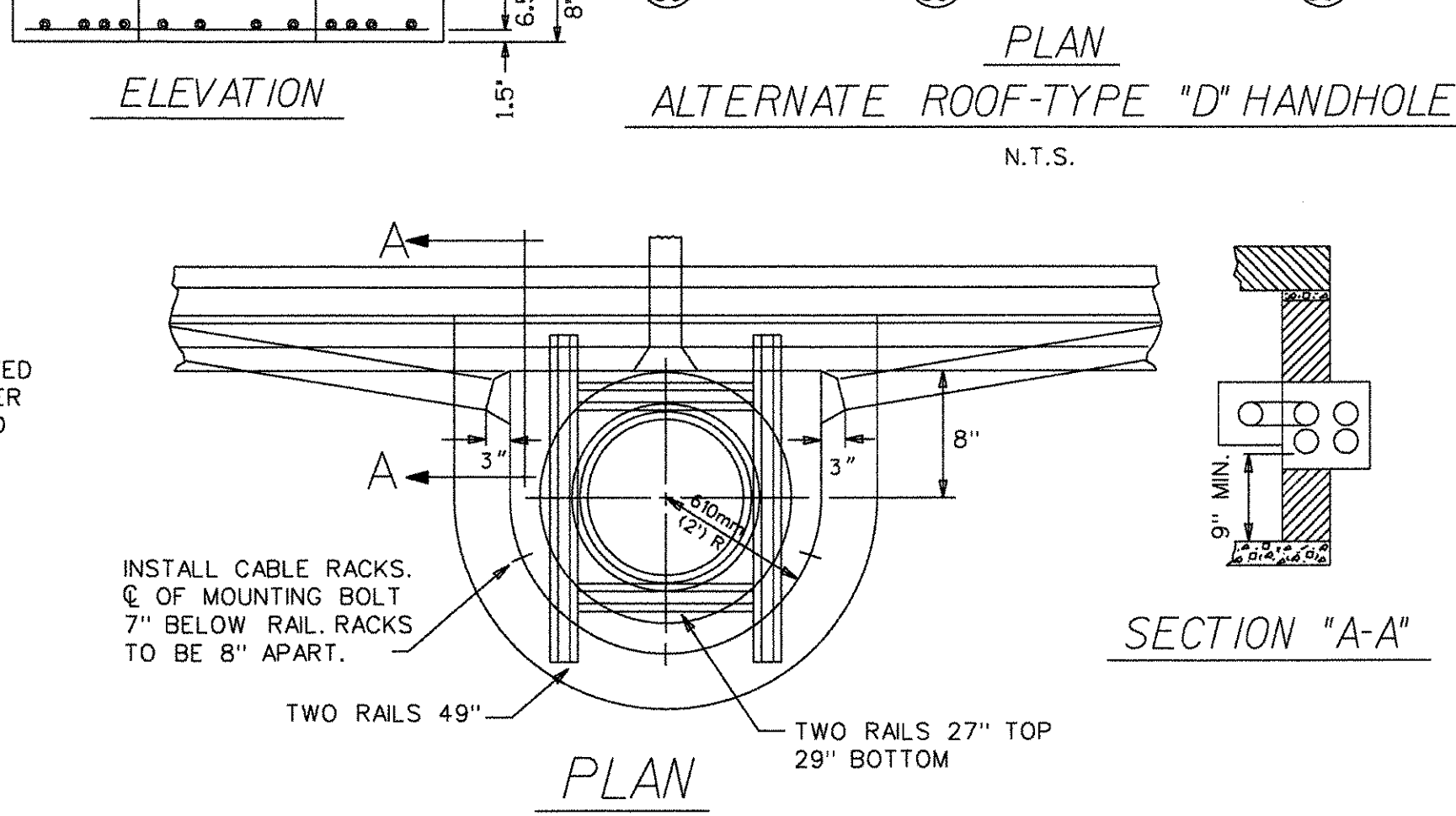
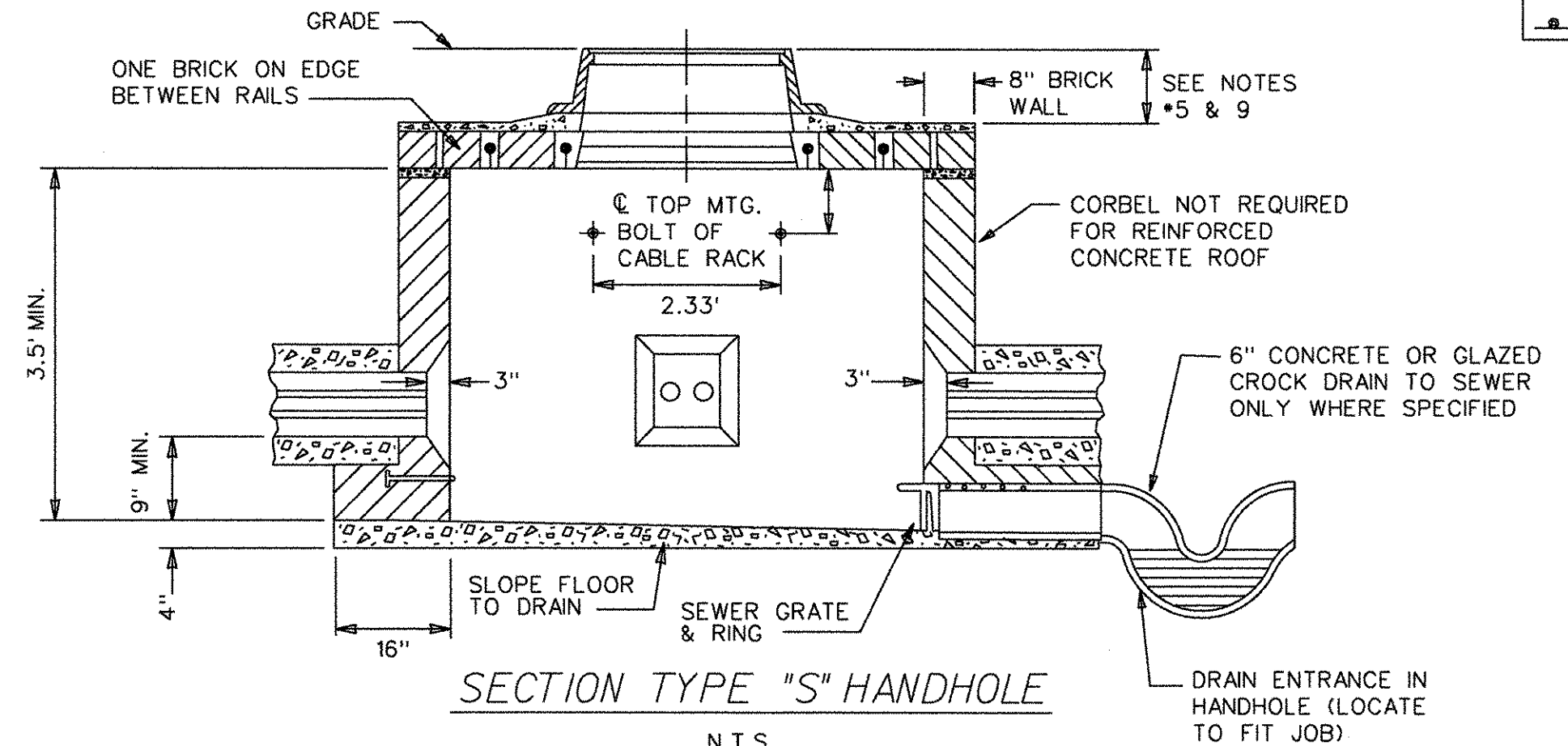
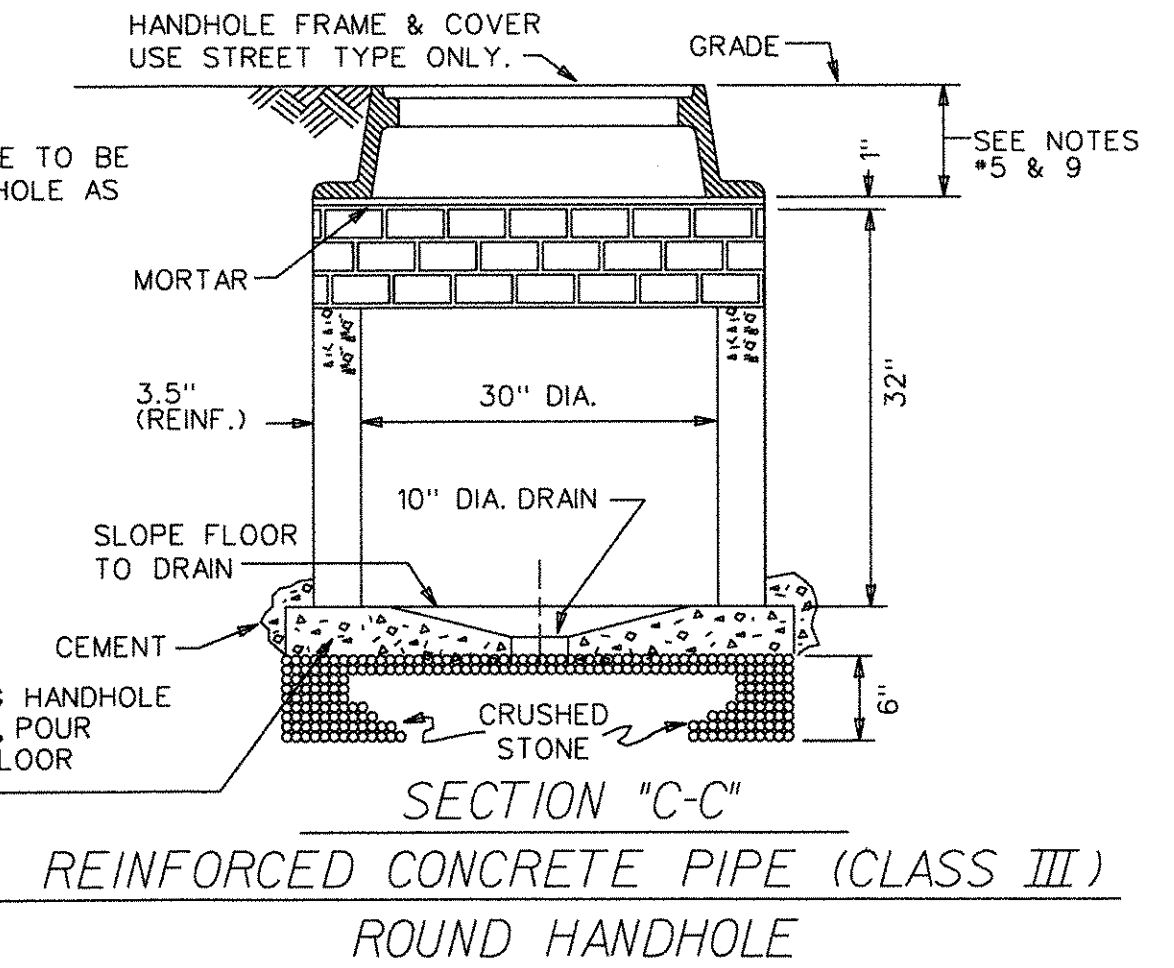

P.L.D. PATTERN NO. 1A
 A.S.T.M. CLASS 20 OR 30 GRAY IRON
 APPROX. 251 LBS.
 HANDHOLE FRAME

NOTE:

- DUCT ENTRANCE TO BE BUILT AS REQUIRED.
- ALL RAILS TO BE 60#/YD. OR HEAVIER.
- CABLE PULLING IRONS TO BE GALVANIZED.
- CABLE RACKS AND ARMS TO BE GALVANIZED.
- IN PAVEMENT PROVIDE AT LEAST 3" BETWEEN ROOF AND BASE OF PAVEMENT. WHERE EXISTING GRADE IS HIGHER THAN PROP. FUTURE GRADE INSTALL BRICK RING OR GROUT (AS REQ'D.) UNDER FRAME TO ALLOW FOR FUTURE FRAME ADJUSTMENT.
- BAR NUMBERS DENOTE THE SIZE OF BAR REQUIRED IN ACCORDANCE WITH CURRENT USAGE SPECIFIED BY THE CONCRETE REINFORCING STEEL INSTITUTE.
- EXCAVATION LIMITS FOR PUBLIC LIGHTING DEPARTMENT HANDHOLES SHALL BE ON VERTICAL PLANES OF THE FOOTING OUTLINE.
- INSTALL ANCHORS & CABLE-RACKS AS SHOWN.
- WHERE HANDHOLES ARE LOCATED BACK OF CURBS ROOF MUST BE BUILT 18" BELOW CURB GRADE, TO PROVIDE FOR FUTURE WIDENING.

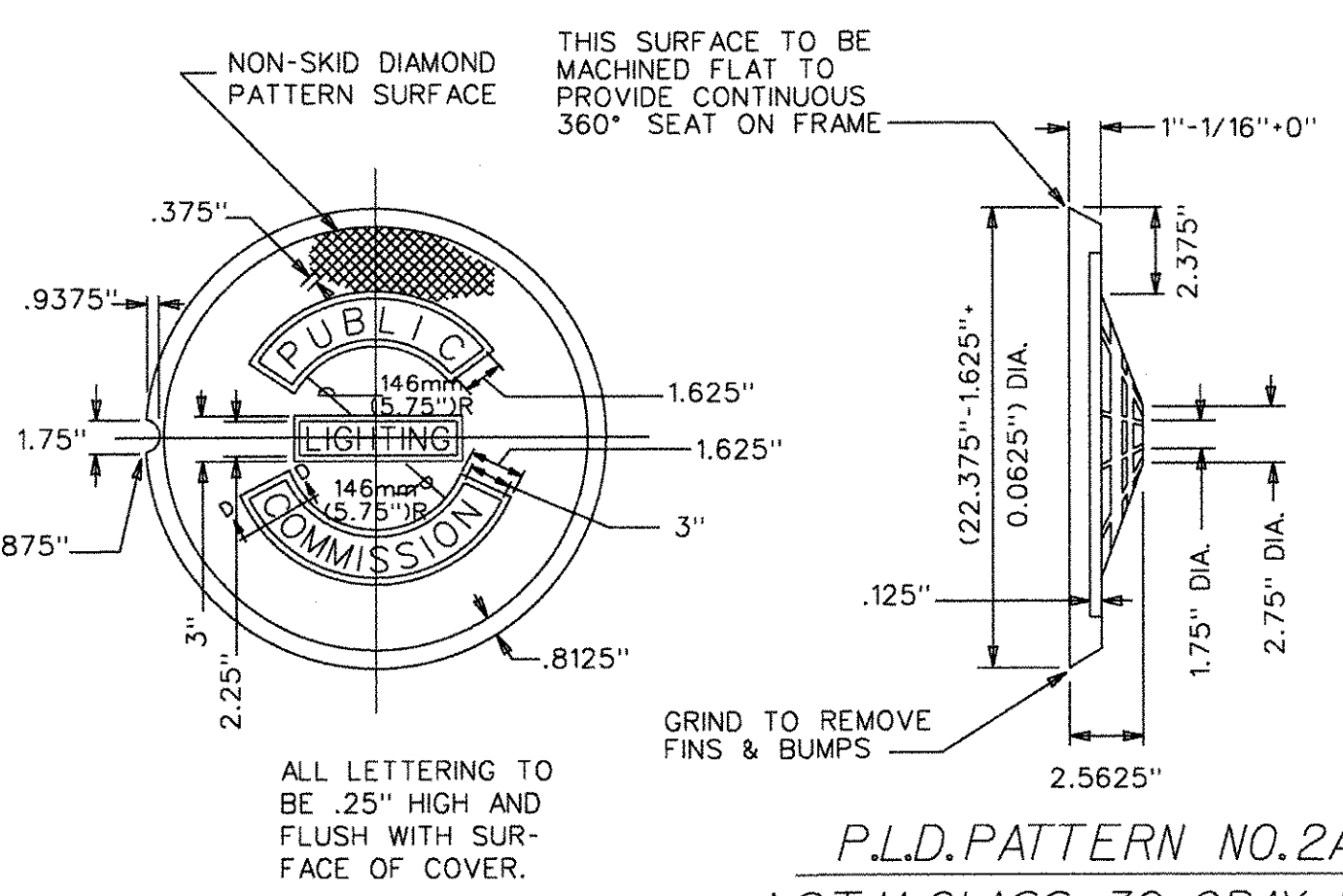
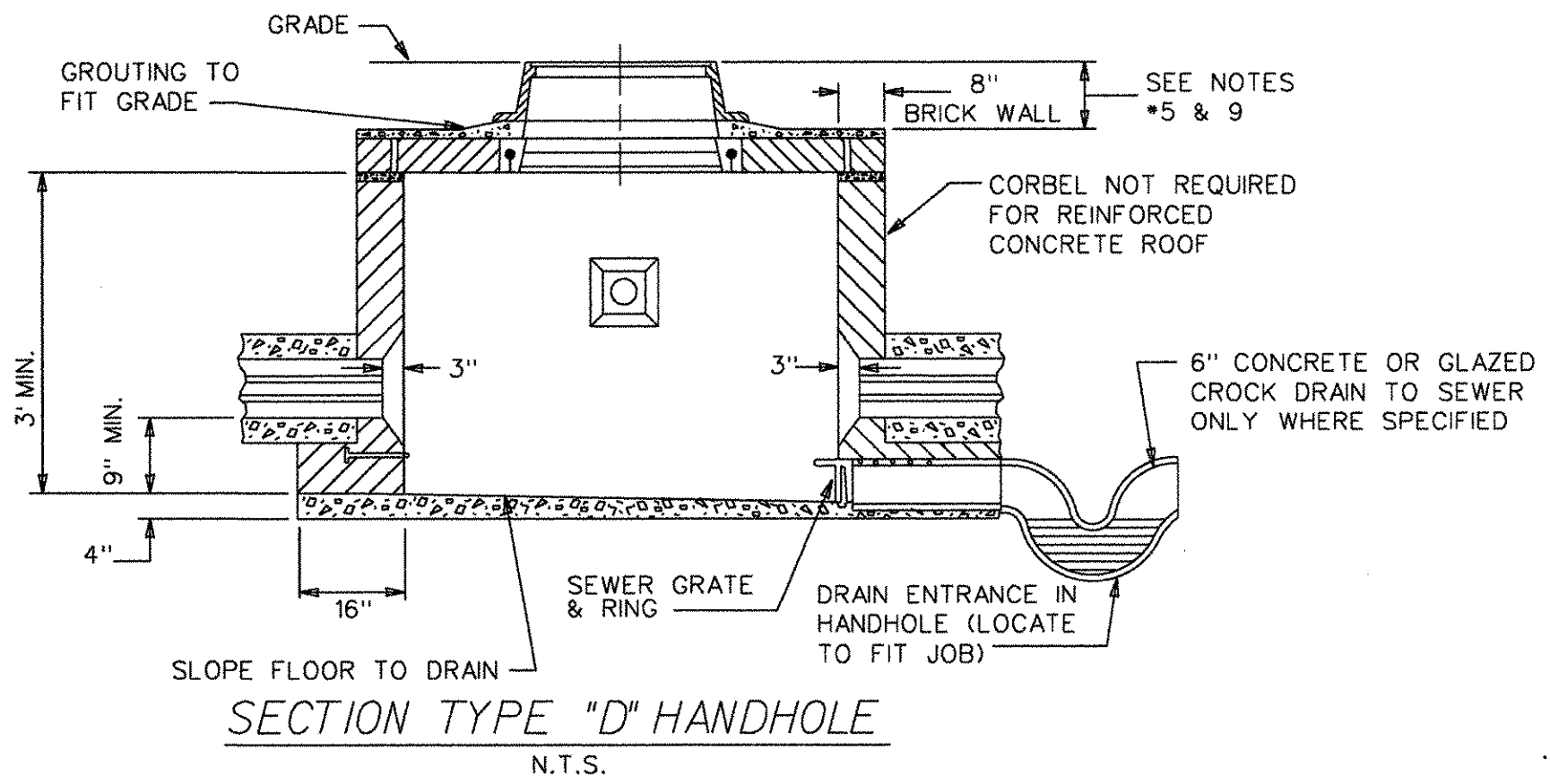

P.L.D. PATTERN NO. 2A
 A.S.T.M. CLASS 30 GRAY IRON
 APPROX. WT. 145 LBS.
 STREET TYPE COVER
 TO BE USED IN STREETS & DRIVES

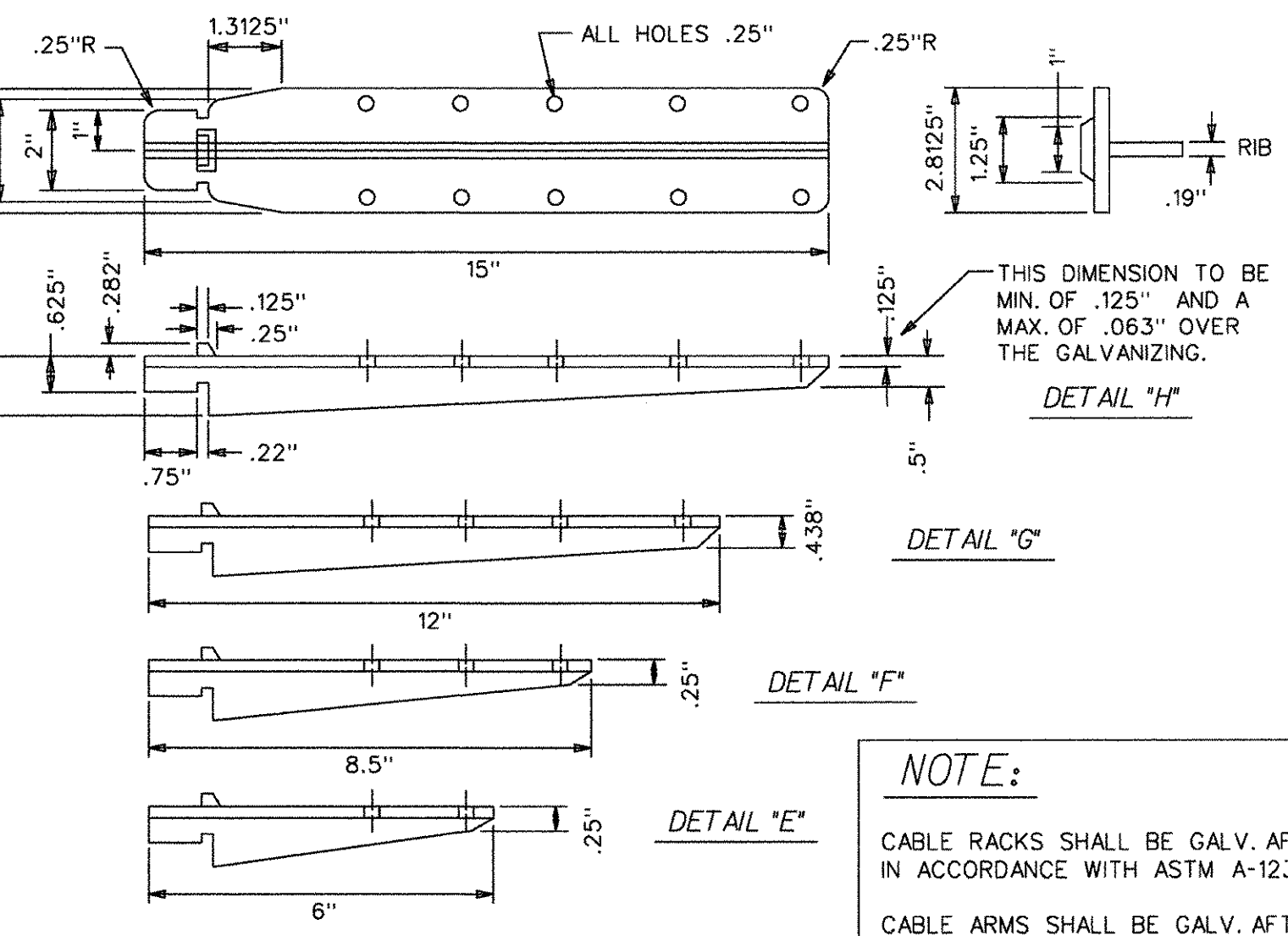
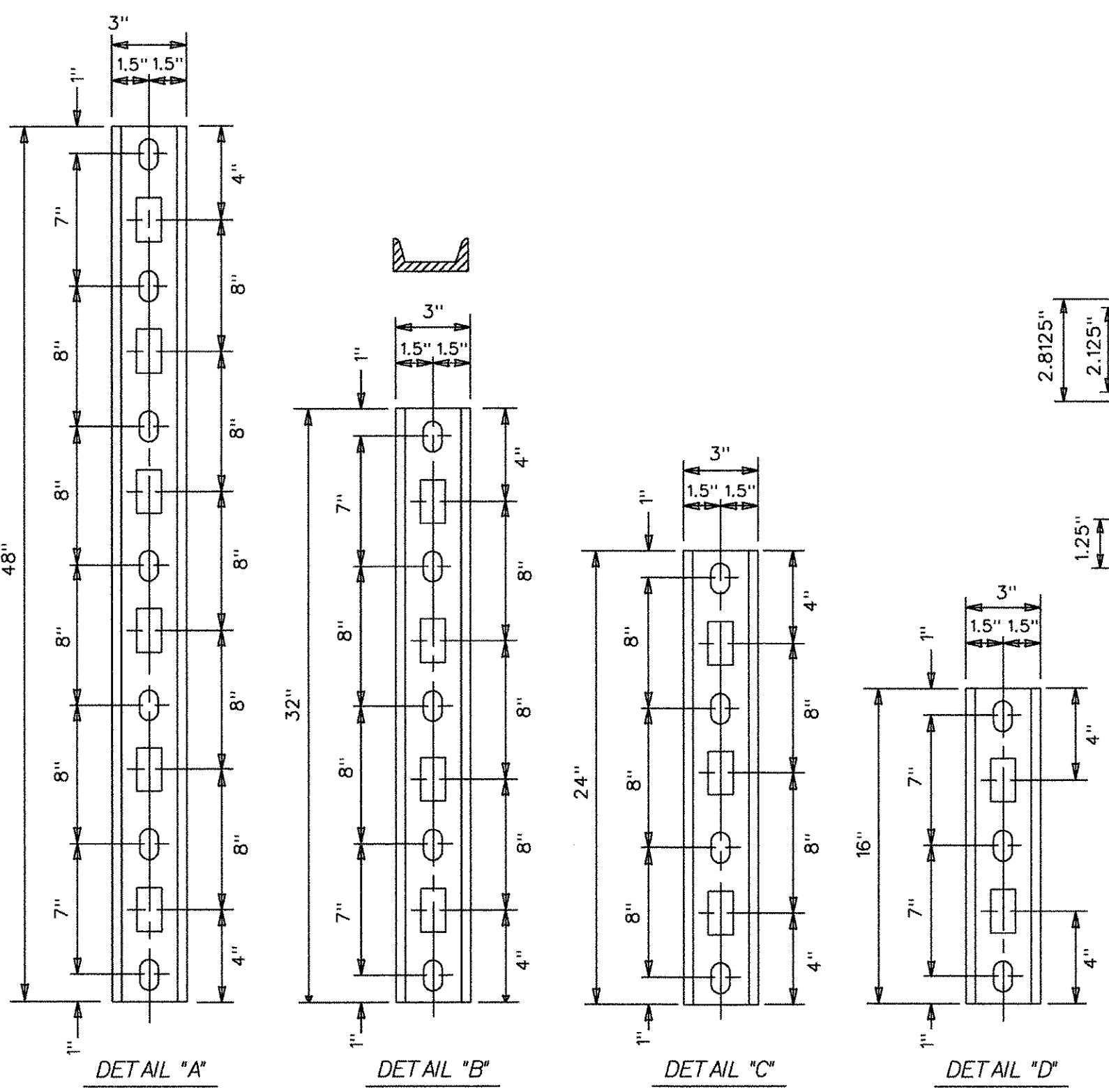
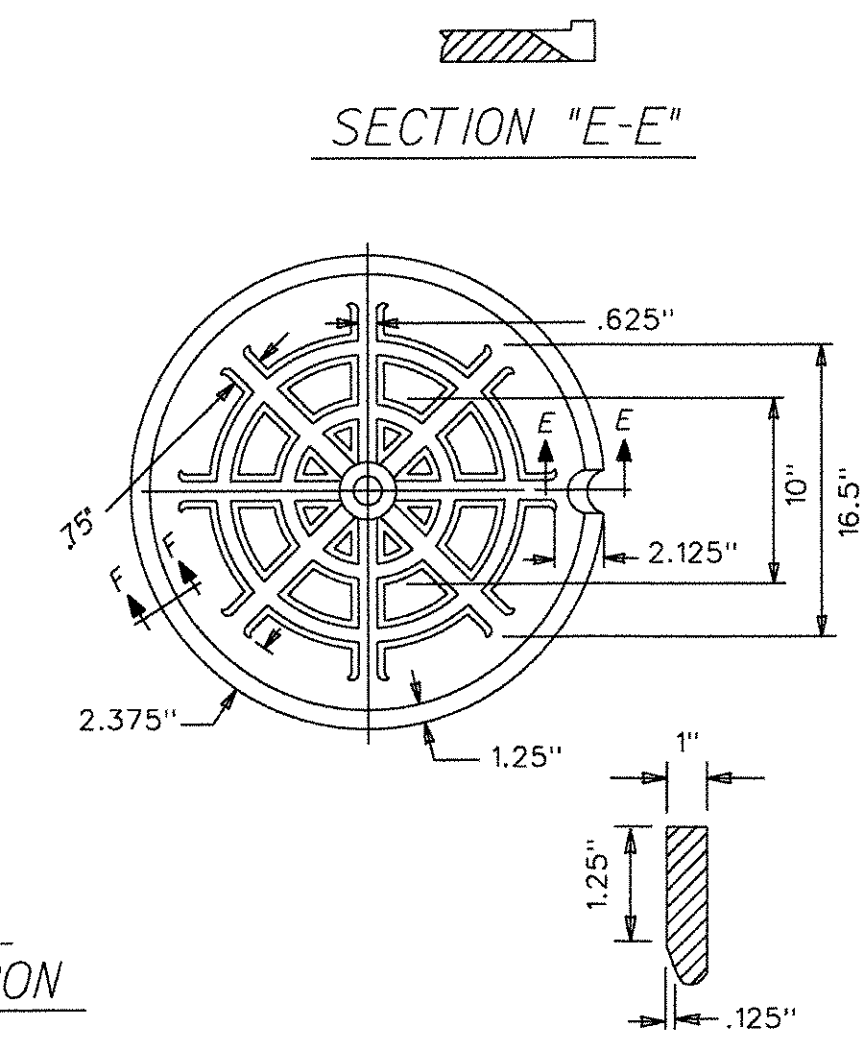

NOTE:
CABLE RACKS SHALL BE GALV. AFTER FAB. IN ACCORDANCE WITH ASTM A-123.
CABLE ARMS SHALL BE GALV. AFTER FAB. IN ACCORDANCE WITH ASTM A-153 53.
ARMS MUST FIT ON INSIDE & OUTSIDE OF RACKS & MUST ALLOW INSULATOR TO FIT LOOSELY.
USE 0.5" GALV. SUPPORTING BOLTS AND EXPANSION ANCHORS.

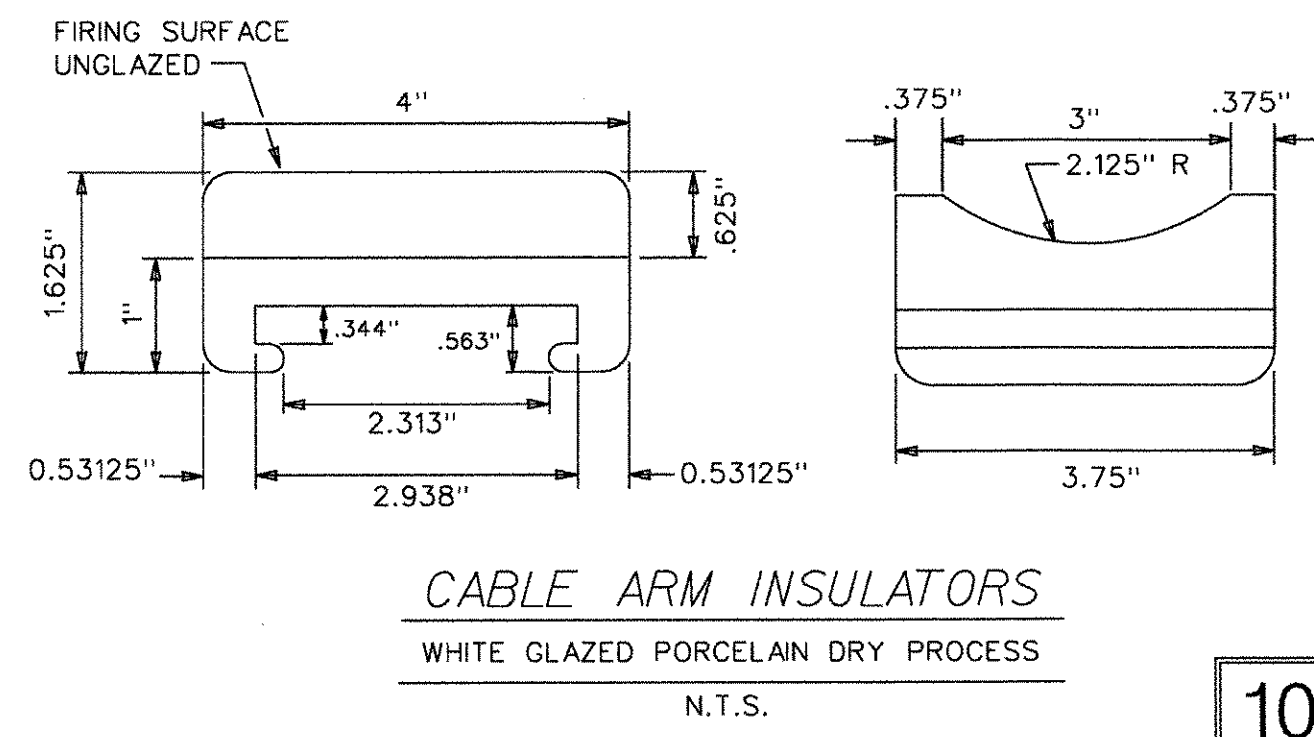
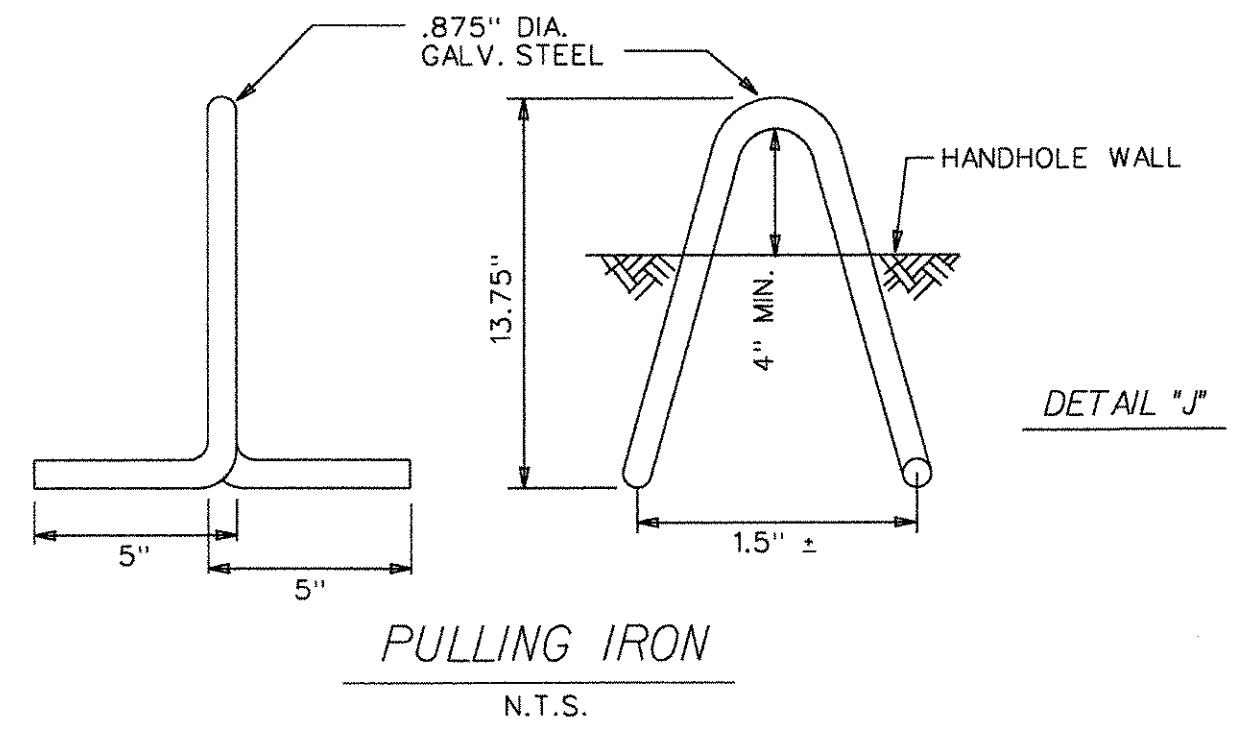

SCALE: AS SHOWN

REVISIONS		
Date	Description	Chkd. by

DETAILS
EAST GRAND BOULEVARD BRIDGE

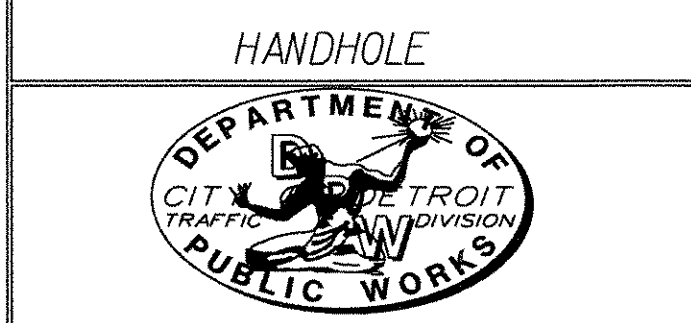

Checked by _____ Approved by _____

PUBLIC LIGHTING DEPARTMENT
CITY OF DETROIT

Checked by _____ Approved by _____ File No. 51-0686

Consulting Engineering Associates, Inc.
 16580 WYOMING AVE. DETROIT MICHIGAN 48221
 TELEPHONE: (313) 341-5797 FAX: 341-0205
 Designed by C.E.A. Checked by _____ Sheet No. 45 of 60
 Disk File Name 103PLDM Job File No. CEA 138200
 Date 3-03-08 Dwg. No. DTL-

REVISION DATE: APRIL 1, 2001
 Computer File: T:\138200 E. Grand Blvd Bridge\DETAILS\104plde.dgn
 DATE PLOTTED: 3/20/2008
 TIME: 2:42:09 PM

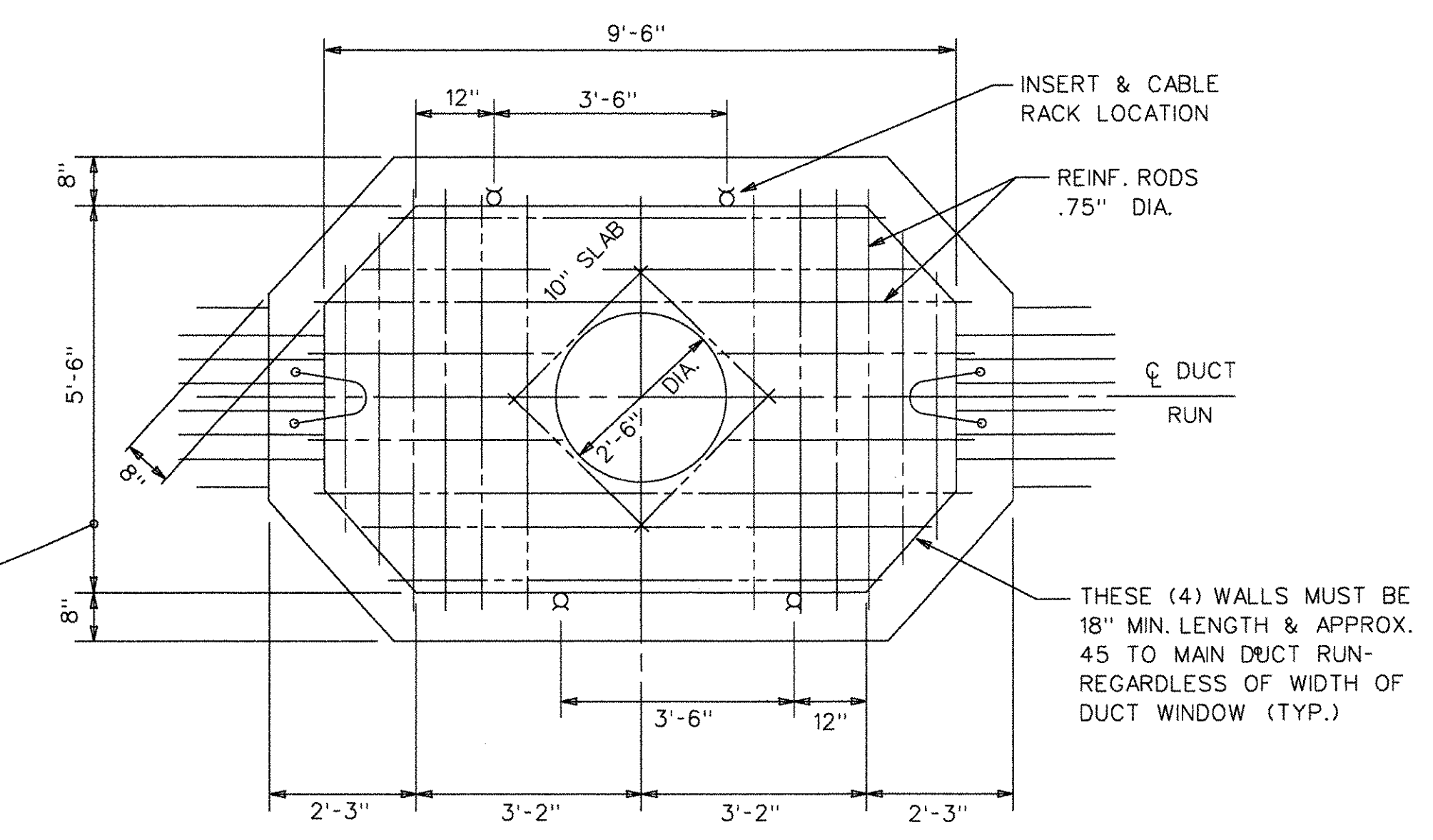
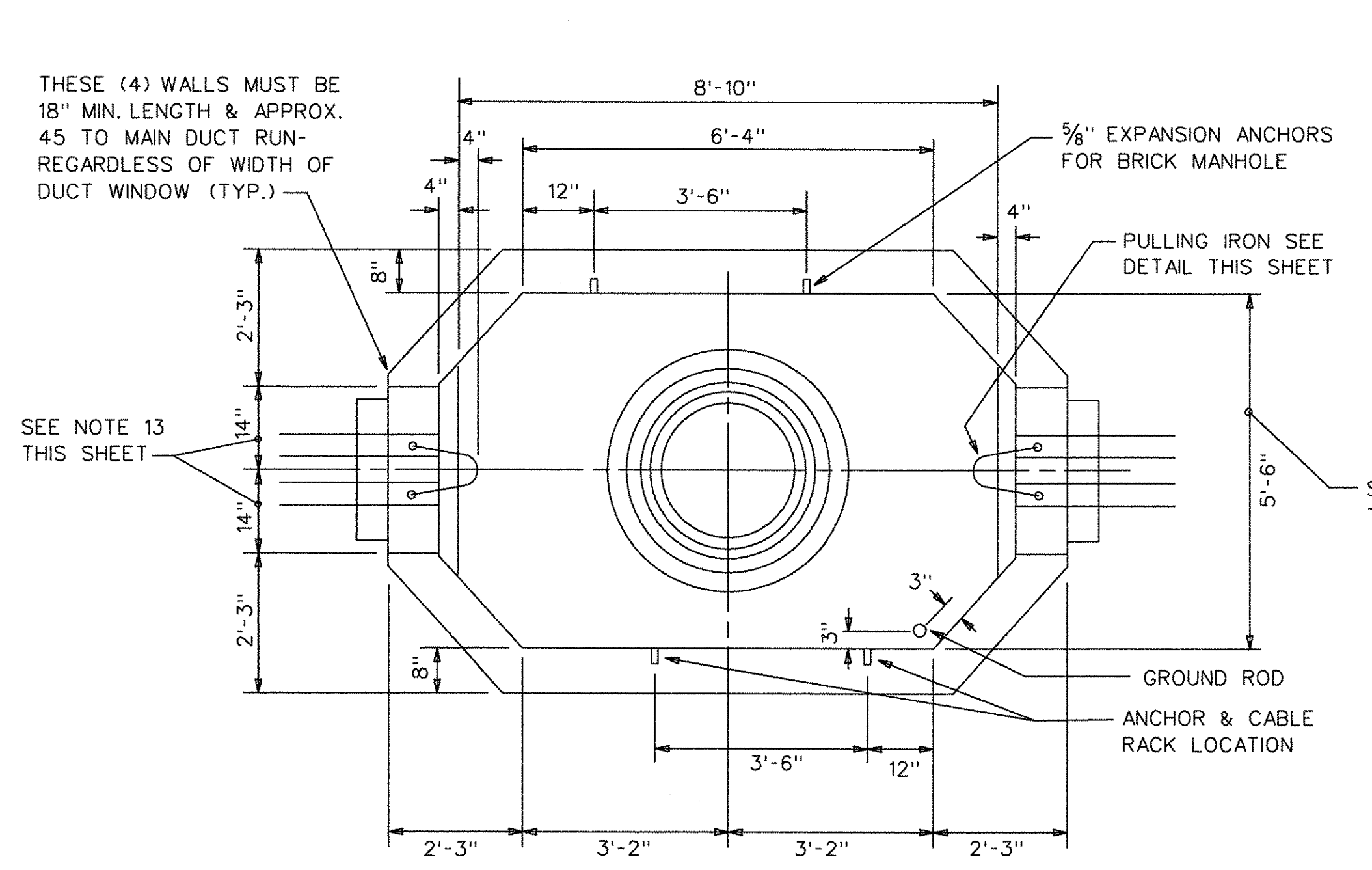

- 10 PIECES 3'-6" LONG
- 2 PIECES 5'-0" LONG
- 8 PIECES 6'-6" LONG
- 2 PIECES 8'-0" LONG
- 4 PIECES 10'-0" LONG

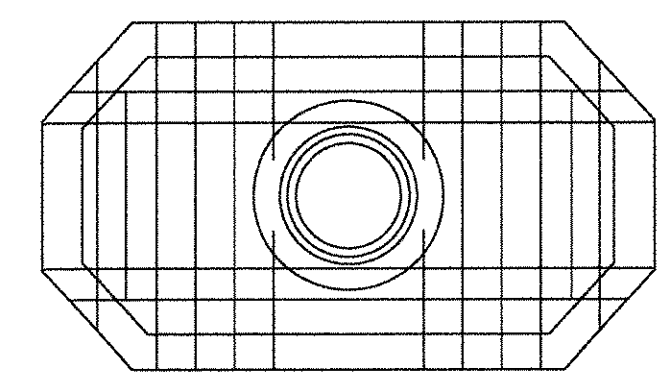
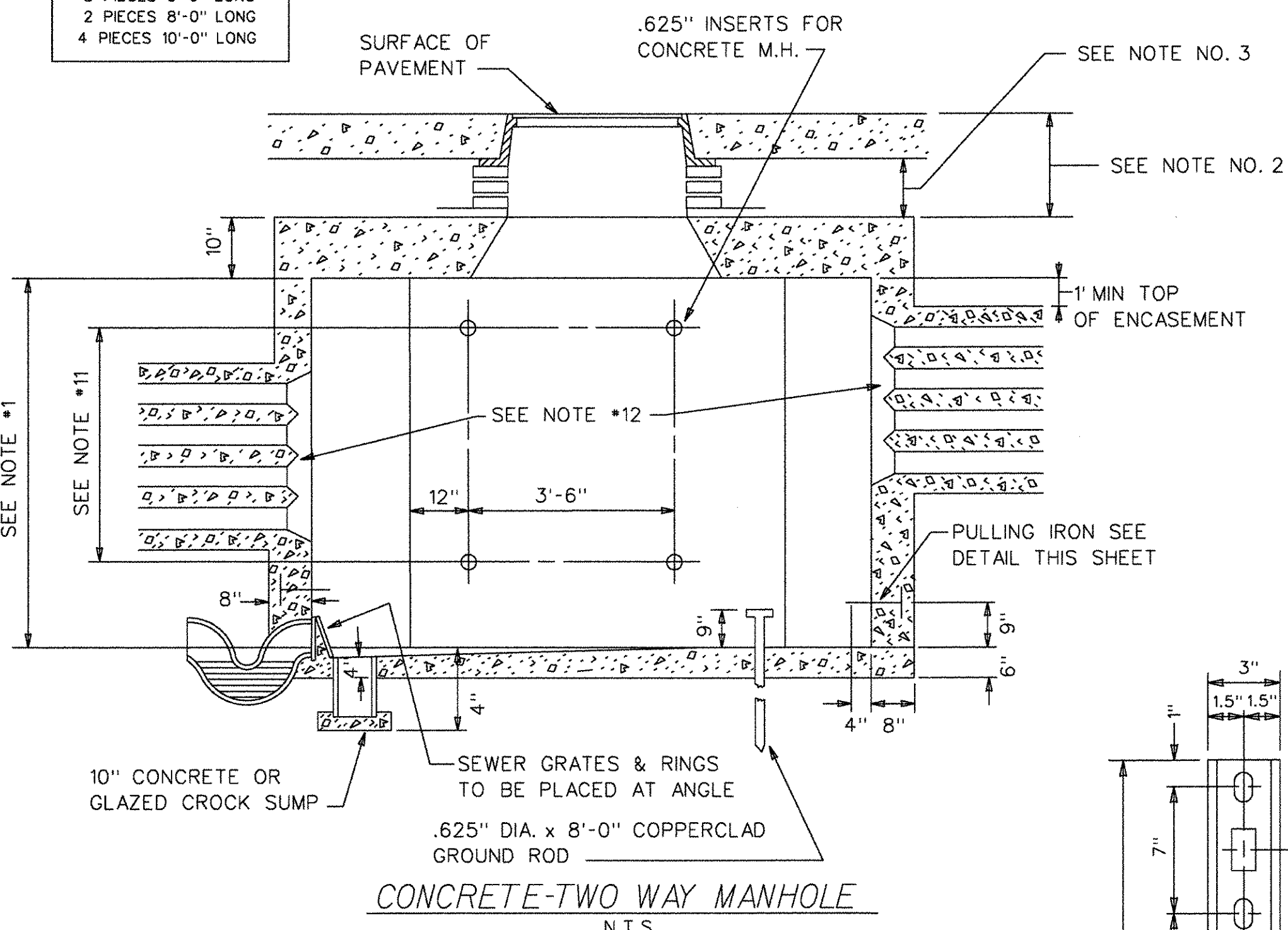
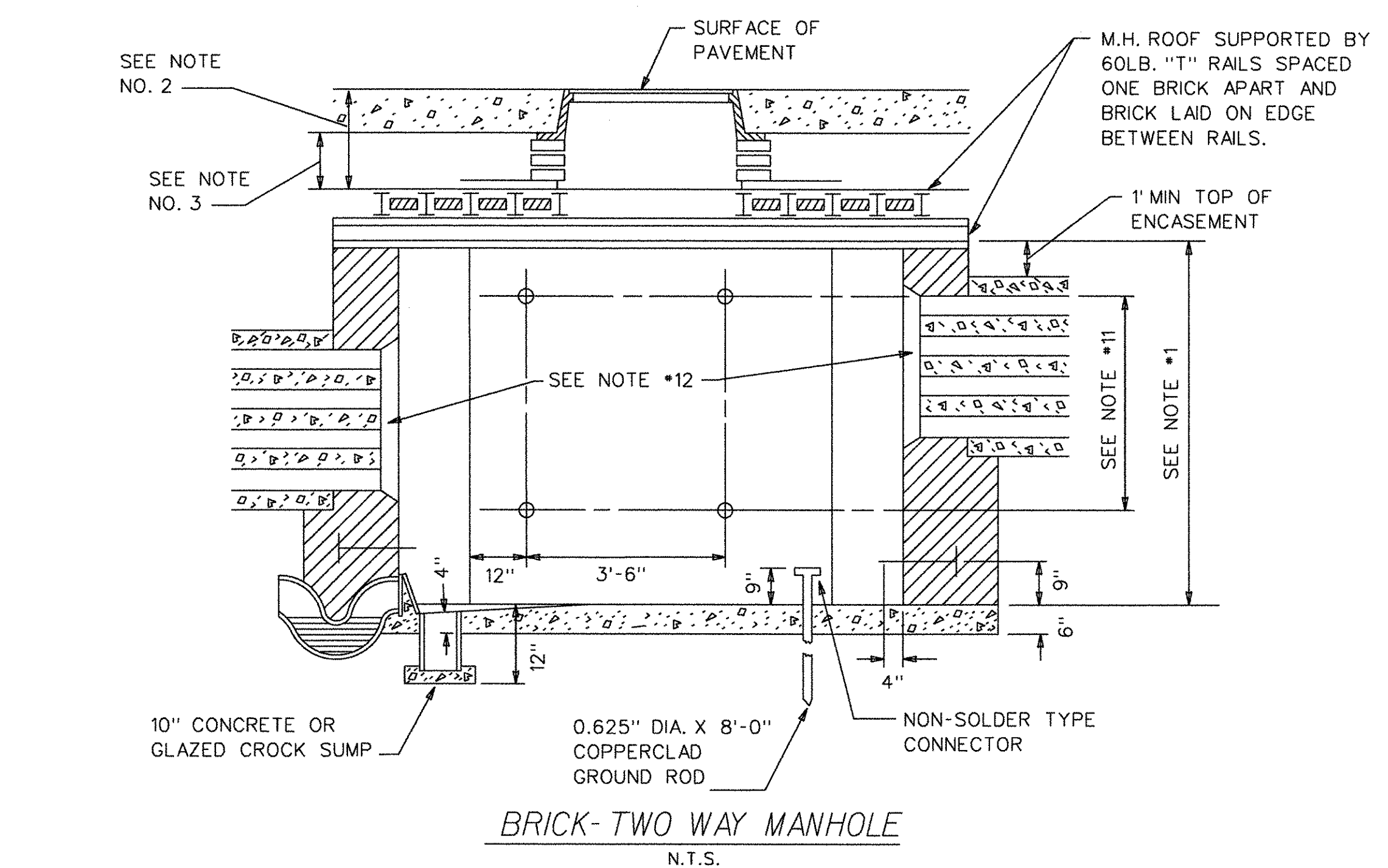

- 2 PIECES 4'-6" LONG
- 2 PIECES 6'-0" LONG
- 6 PIECES 6'-10" LONG
- 2 PIECES 9'-3" LONG
- 2 PIECES 10'-8" LONG
- TOTAL WEIGHT 927kg (2040 LB.)

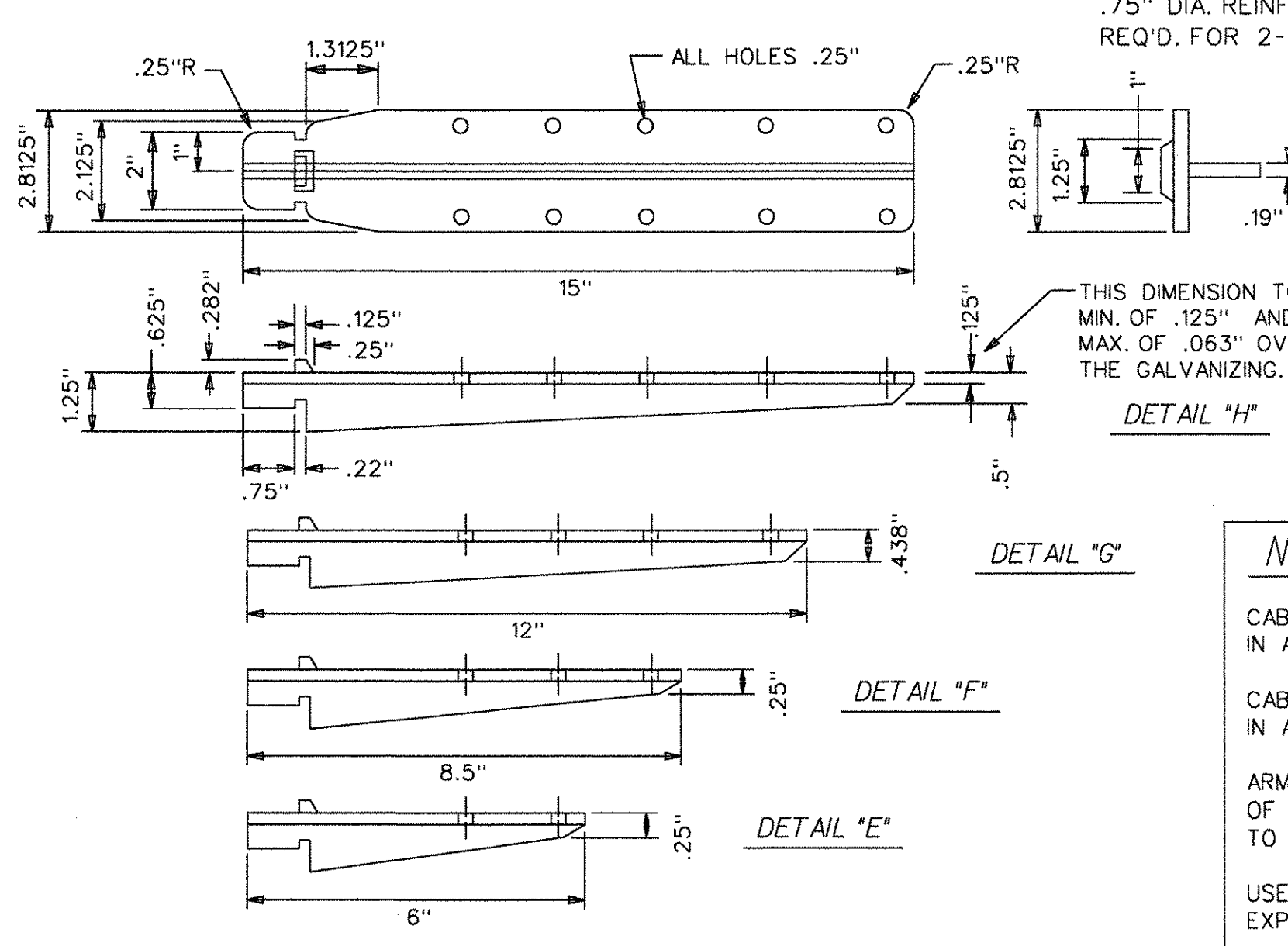
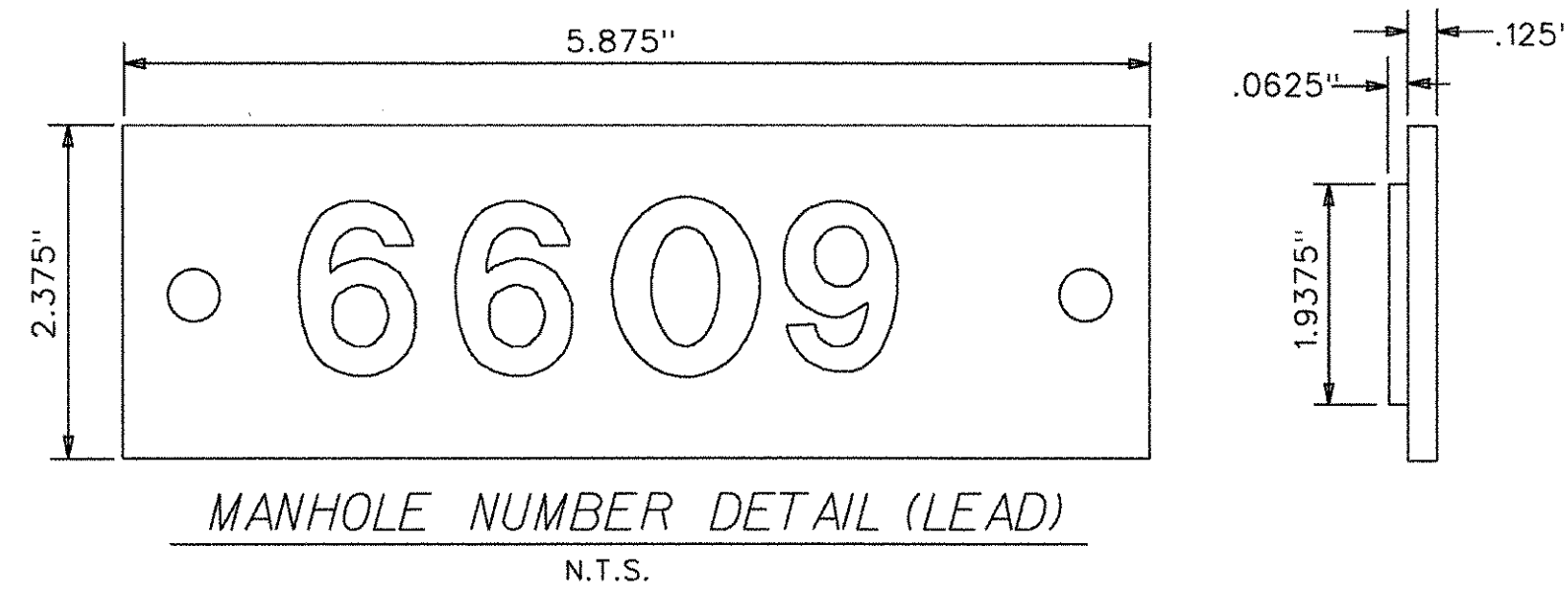
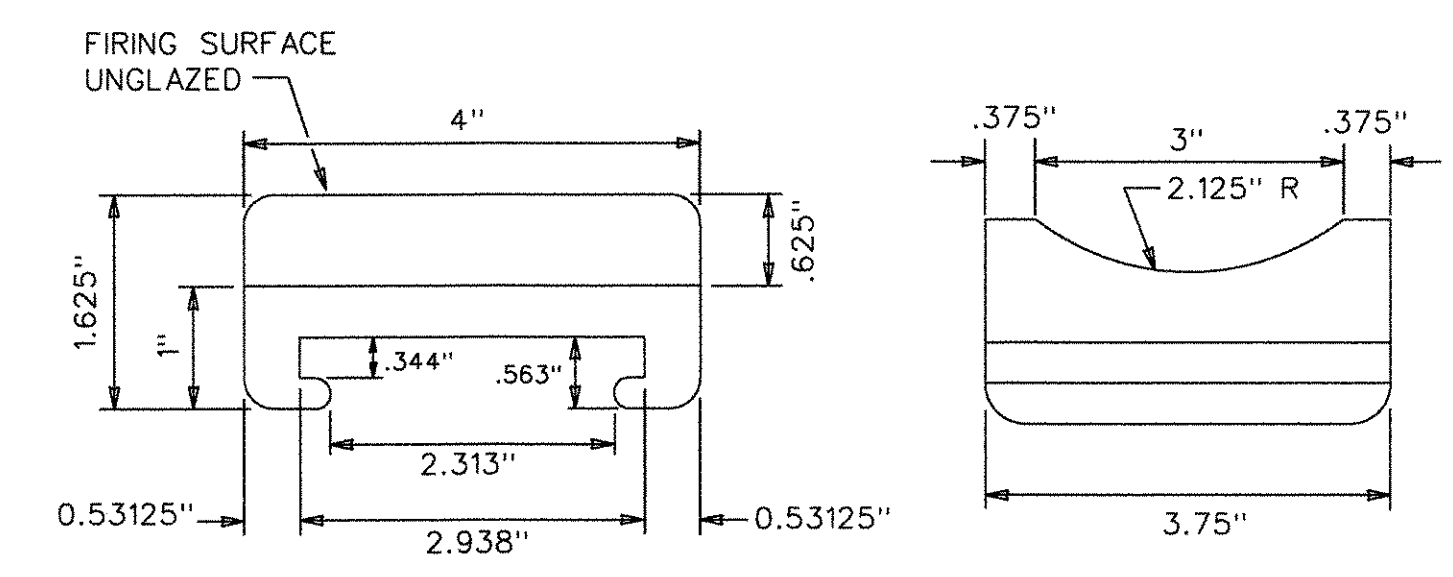

NOTE:
 CABLE RACKS SHALL BE GALV. AFTER FAB. IN ACCORDANCE WITH ASTM A-123.
 CABLE ARMS SHALL BE GALV. AFTER FAB. IN ACCORDANCE WITH ASTM A-153 53.
 ARMS MUST FIT ON INSIDE & OUTSIDE OF RACKS & MUST ALLOW INSULATOR TO FIT LOOSELY.
 USE 0.5" GALV. SUPPORTING BOLTS AND EXPANSION ANCHORS.

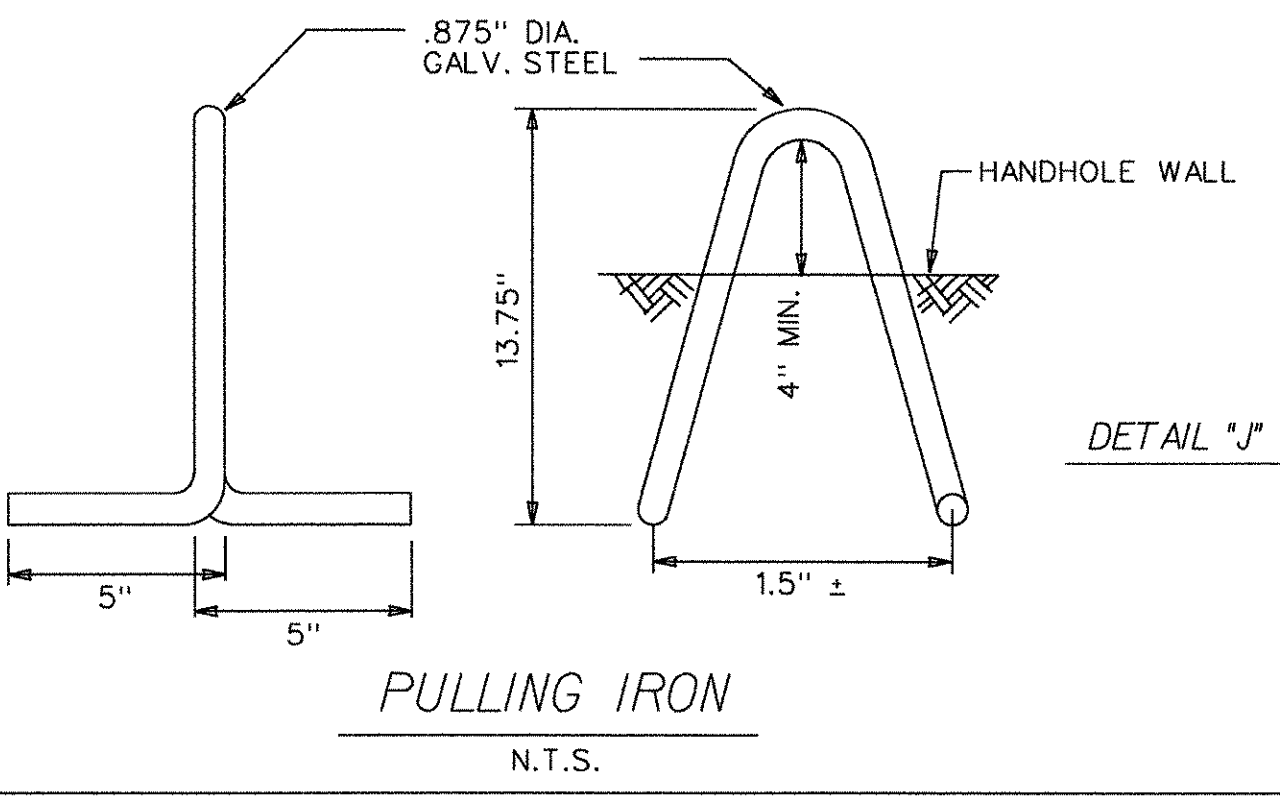
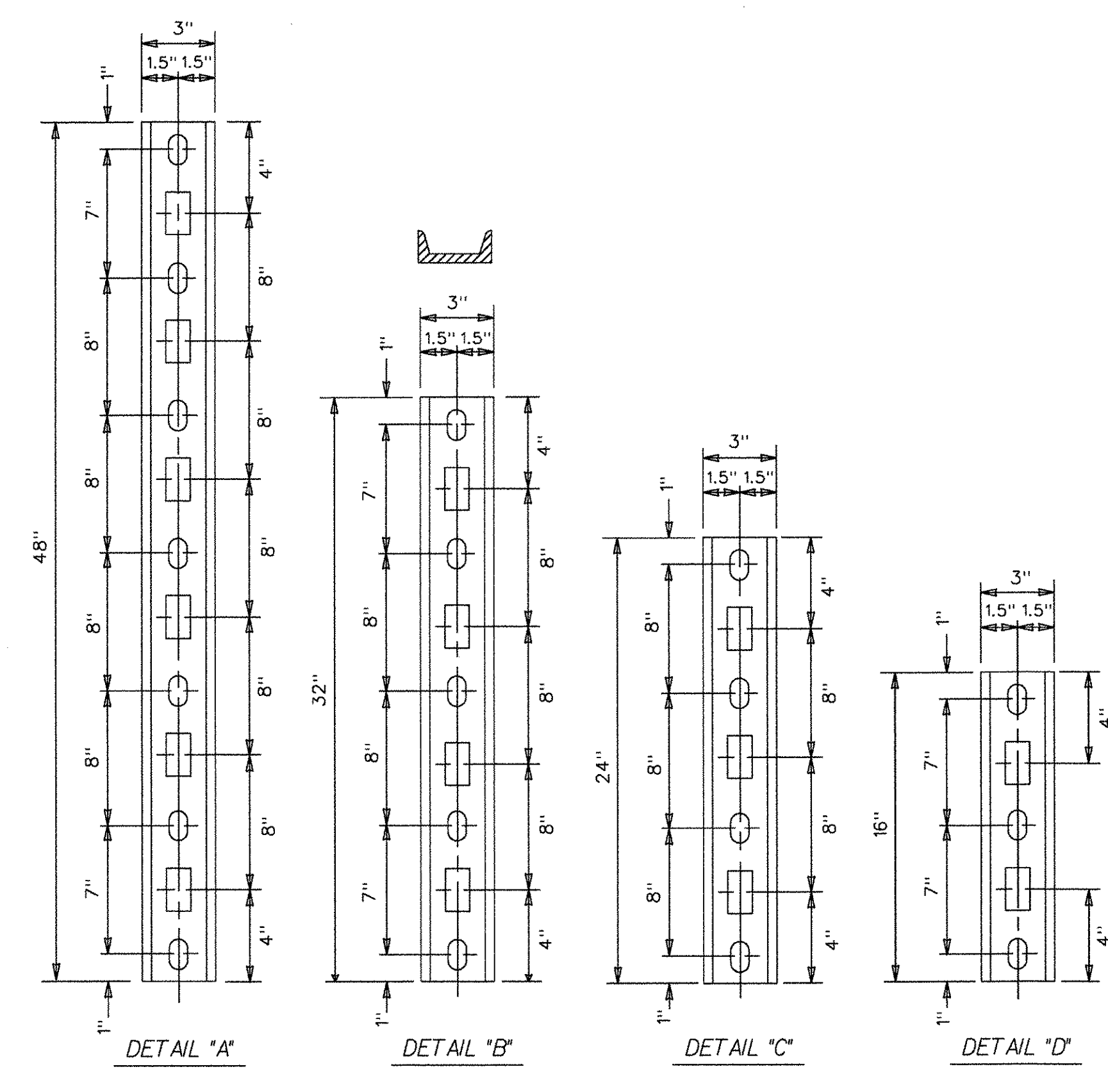

CABLE RACKS
 75mm(3") STD. 4.1" CHANNEL
 N.T.S.

- NOTE:**
- THIS DIMENSION NORMALLY 6'6" SEE SPECIFICATIONS FOR UNUSUAL CONDITIONS.
 - WHERE M.H.'S ARE LOCATED BACK OF CURBS, TOP OF M.H. ROOF MUST BE BUILT 26" BELOW CURB GRADE TO PROVIDE FOR FUTURE PAVEMENT.
 - IN EXISTING PAVEMENT, PROVIDE AT LEAST 8" BETWEEN TOP OF ROOF AND BASE OF PAVEMENT
 - BOLTS, RACKS & PULLING IRONS TO BE HOT-DIP GALV.
 - ☉ OF RAILS & UNDER M.H. FRAME FLANGE TO BE APPROX. 18" ROM C'S OF FRAMES.
 - M.H. NUMBER TO BE INSTALLED ON MANHOLE WALL IN CONSPICUOUS PLACE.
 - MOUNTING HEIGHT FOR LOWER BOLTS OF CABLE RACK SHALL BE THE AVERAGE HEIGHT OF THE BOTTOM OF THE LOWEST DUCTS IN MAIN CONDUITS. INSTALL MIN. (2) 48" LONG RACKS ON WALLS.
 - 8" THICK CHIMNEYS WHERE SPECIFIED SHALL BE INCIDENTAL TO APPLICABLE M.H. ITEM.
 - EXCAVATION LIMITS FOR PUBLIC LIGHTING DEPARTMENT MANHOLES SHALL BE ON VERTICAL PLANES ON THE FOOTING OUTLINE.
 - .5" PLASTER OUTSIDE WALLS OF BRICK MANHOLES.
 - SPACING OF INSERTS AS REQUIRED TO ACCOMMODATE CABLE RACK
 - BELL ENDS ARE REQUIRED ON EACH CONDUIT ENTERING MANHOLE. (TYPE AND SIZE SHALL BE IDENTICAL TO CONDUIT TYPE AND SIZE)
 - THIS IS A MINIMUM DIMENSION & IS EXPANDABLE TO ACCOMMODATE MAIN DUCT WINDOW.
 - FOUR HEAVY 48" CABLE RACKS, 8 -15" CABLE ARMS & 16-CABLE ARM INSULATORS REQUIRED PER MANHOLE, UNLESS SPECIFIED OTHERWISE.
 - CONTRACTOR IS TO INSTALL MANHOLE NO. TAG FURNISHED BY P.L.D. MANHOLE SHALL NOT BE CONSIDERED COMPLETE WITHOUT MANHOLE NO. TAG INSTALLED.

SCALE: AS SHOWN

REVISIONS		
Date	Description	Chkd. by

DETAILS
 EAST GRAND BOULEVARD BRIDGE



PUBLIC LIGHTING DEPARTMENT
 CITY OF DETROIT
 Checked by _____ Approved by _____
 File No. 51-0686

Consulting Engineering Associates, Inc.
 16580 WYOMING AVE. DETROIT MICHIGAN 48221
 TELEPHONE: (313) 341-5797 FAX: 341-0205
 Designed by C.E.A. Checked by _____ Sheet No. 46 of 60
 Disk File Name 104PLDM Job File No. CEA 138200
 Date 3-03-08 Dwg. No. DTL-2-

NOTE:

- THIS DIMENSION NORMALLY 6.5' SEE SPECIFICATIONS FOR UNUSUAL CONDITIONS.
- WHERE M.H.'S ARE LOCATED BACK OF CURBS, TOP OF M.H. ROOF MUST BE BUILT 26" BELOW CURB GRADE TO PROVIDE FOR FUTURE PAVEMENT.
- IN EXISTING PAVEMENT, PROVIDE AT LEAST 8" BETWEEN TOP OF ROOF AND BASE OF PAVEMENT
- BOLTS, RACKS & PULLING IRONS TO BE HOT-DIP GALV.
- CL OF RAILS & UNDER M.H. FRAME FLANGE TO BE APPROX. 18" FROM C'S OF FRAMES.
- M.H. NUMBER TO BE INSTALLED ON MANHOLE WALL IN CONSPICUOUS PLACE.
- MOUNTING HEIGHT FOR LOWER BOLTS OF CABLE RACK SHALL BE THE AVERAGE HEIGHT OF THE BOTTOM OF THE LOWEST DUCTS IN MAIN CONDUITS. INSTALL MIN. (2) 8" LONG RACKS ON WALLS.
- 8" THICK CHIMNEYS WHERE SPECIFIED SHALL BE INCIDENTAL TO APPLICABLE M.H. ITEM.
- EXCAVATION LIMITS FOR PUBLIC LIGHTING DEPARTMENT MANHOLES SHALL BE ON VERTICAL PLANES ON THE FOOTING OUTLINE.
- 0.5" PLASTER OUTSIDE WALLS OF BRICK MANHOLES.
- SPACING OF INSERTS AS REQUIRED TO ACCOMMODATE CABLE RACK
- BELL ENDS ARE REQUIRED ON EACH CONDUIT ENTERING MANHOLE. (TYPE AND SIZE SHALL BE IDENTICAL TO CONDUIT TYPE AND SIZE)
- THIS IS A MINIMUM DIMENSION & IS EXPANDABLE TO ACCOMMODATE MAIN DUCT WINDOW.
- EIGHT HEAVY 48" CABLE RACKS, (16) 15" CABLE ARMS & 32 CABLE ARMS INSULATORS REQUIRED PER MANHOLE, UNLESS SPECIFIED OTHERWISE.
- CONTRACTOR IS TO INSTALL MANHOLE NO. TAG FURNISHED BY P.L.D. MANHOLE SHALL NOT BE CONSIDERED COMPLETE WITHOUT MANHOLE NO. TAG INSTALLED.

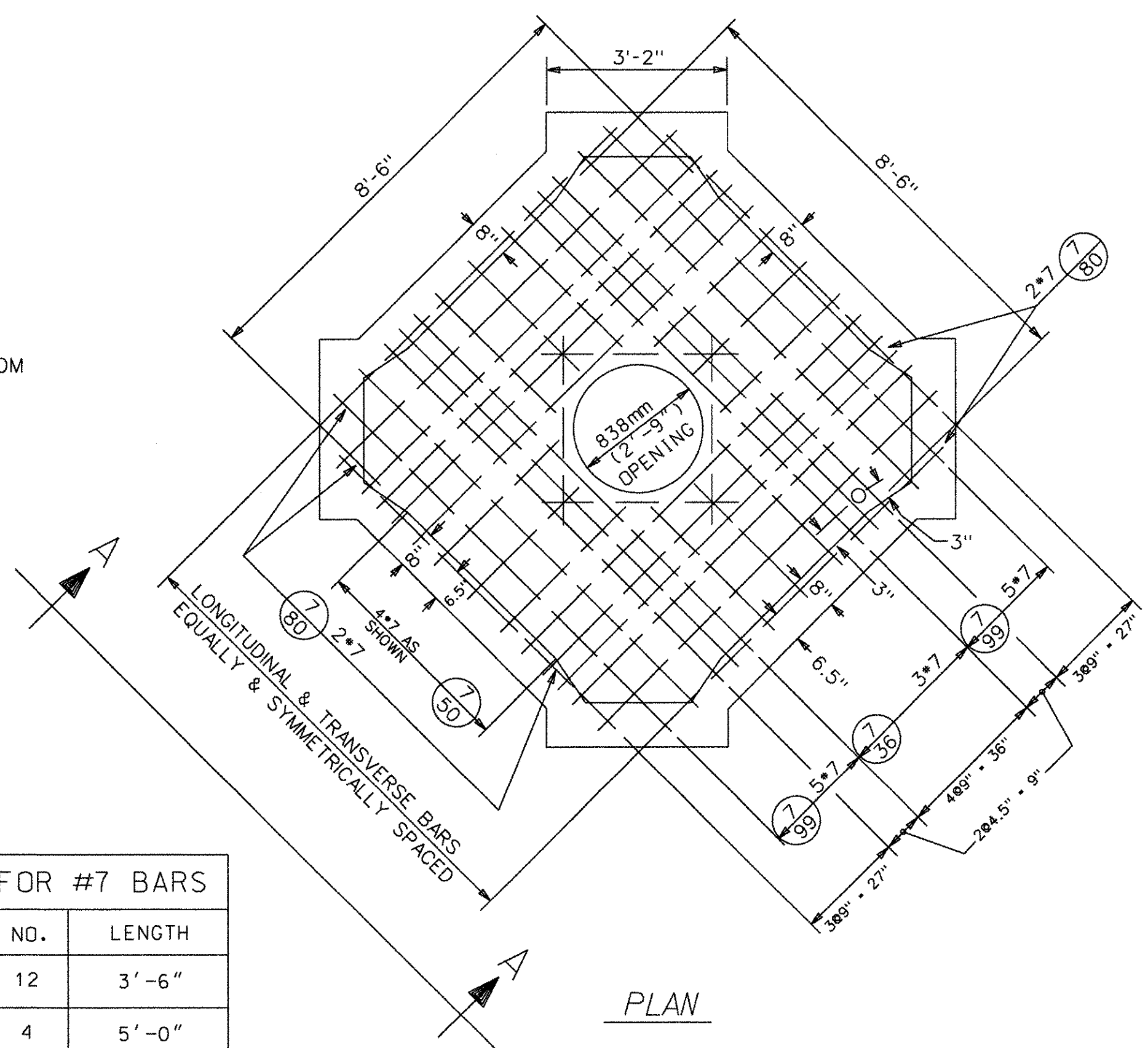

MARK	NO.	LENGTH
⑦/36	12	3'-6"
⑦/50	4	5'-0"
⑦/80	4	8'-0"
⑦/99	20	9'-9"

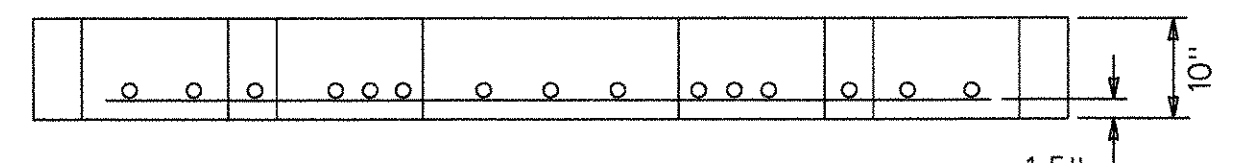

ELEVATION "A-A"
FOUR-WAY MANHOLE ROOF
ALTERNATE CONCRETE

- 27Kg (60 LB.) "T" RAILS**
- 4 PIECES 12.5' LONG
 - 4 PIECES 9.5' LONG
 - 4 PIECES 8' LONG
 - 4 PIECES 6.5' LONG
 - 4 PIECES 5' LONG
 - 4 PIECES 3.5' LONG

"T" RAIL SPECIFICATIONS
27kg (60 LBS.) PER YD. OR HEAVIER
N.T.S.

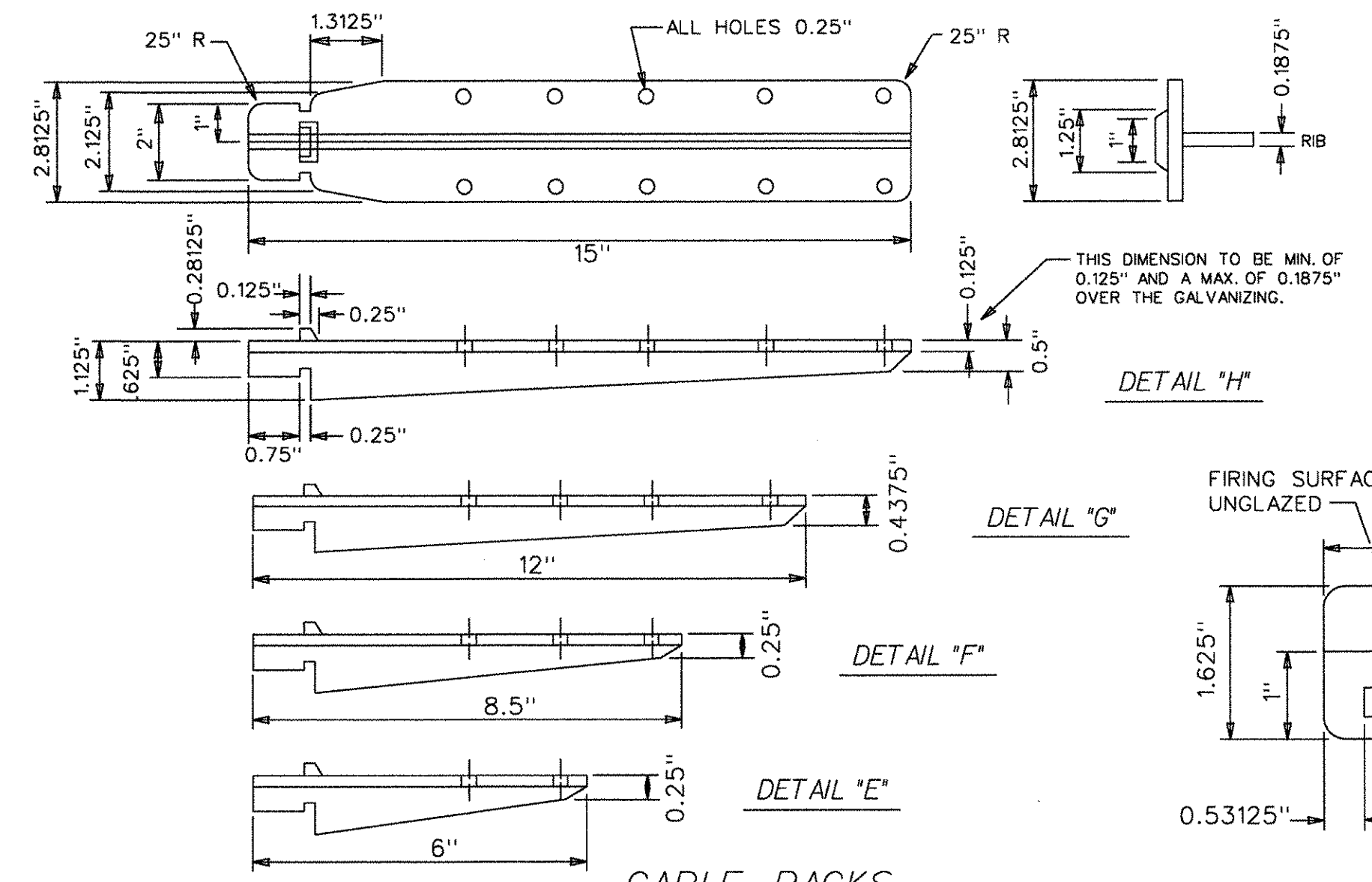

CABLE RACKS
MALLEABLE CAST IRON
N.T.S.

CABLE ARM INSULATORS
WHITE GLAZED PORCELAIN DRY PROCESS
N.T.S.

PULLING IRON
N.T.S.

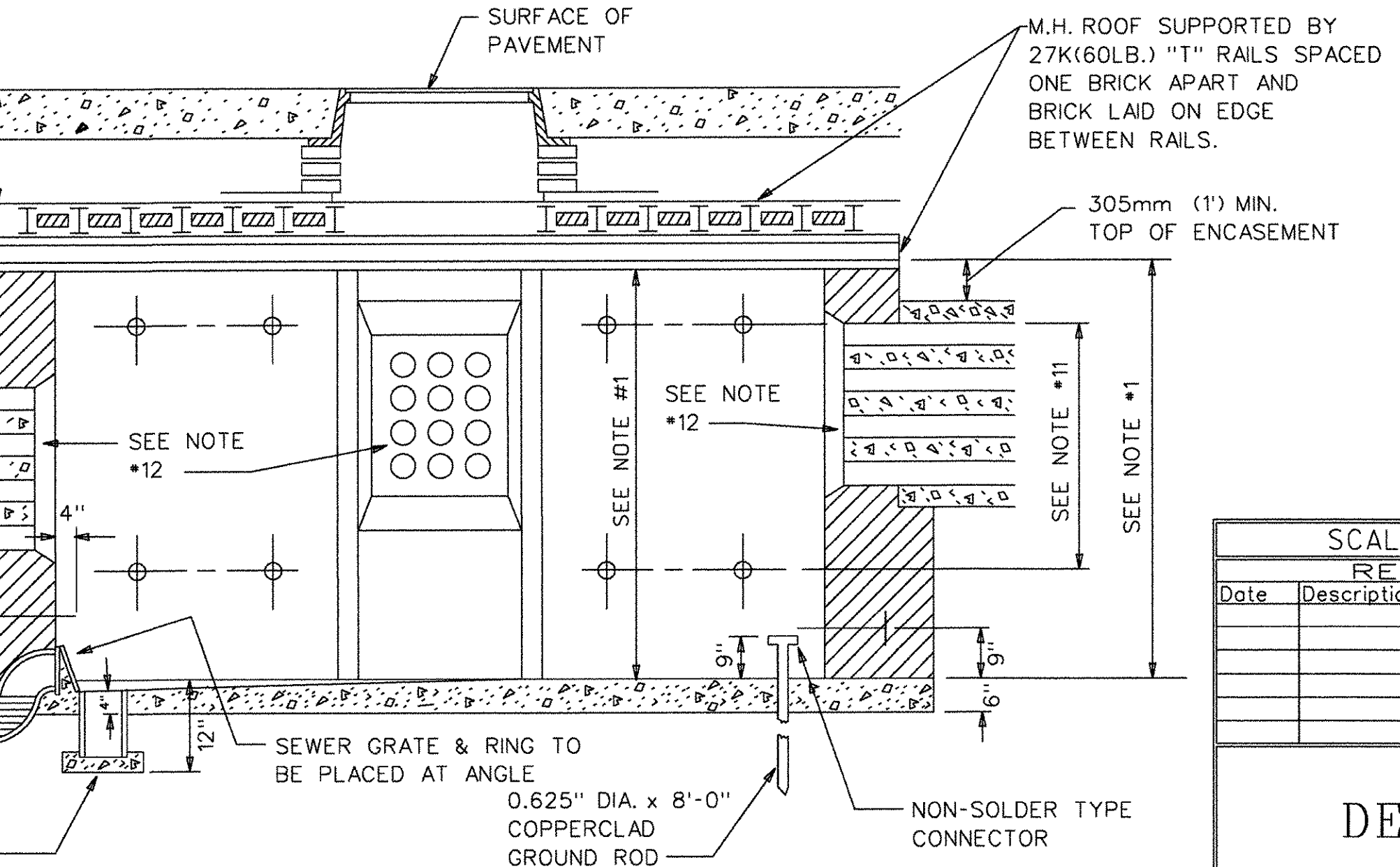

BRICK-FOUR WAY MANHOLE
N.T.S.

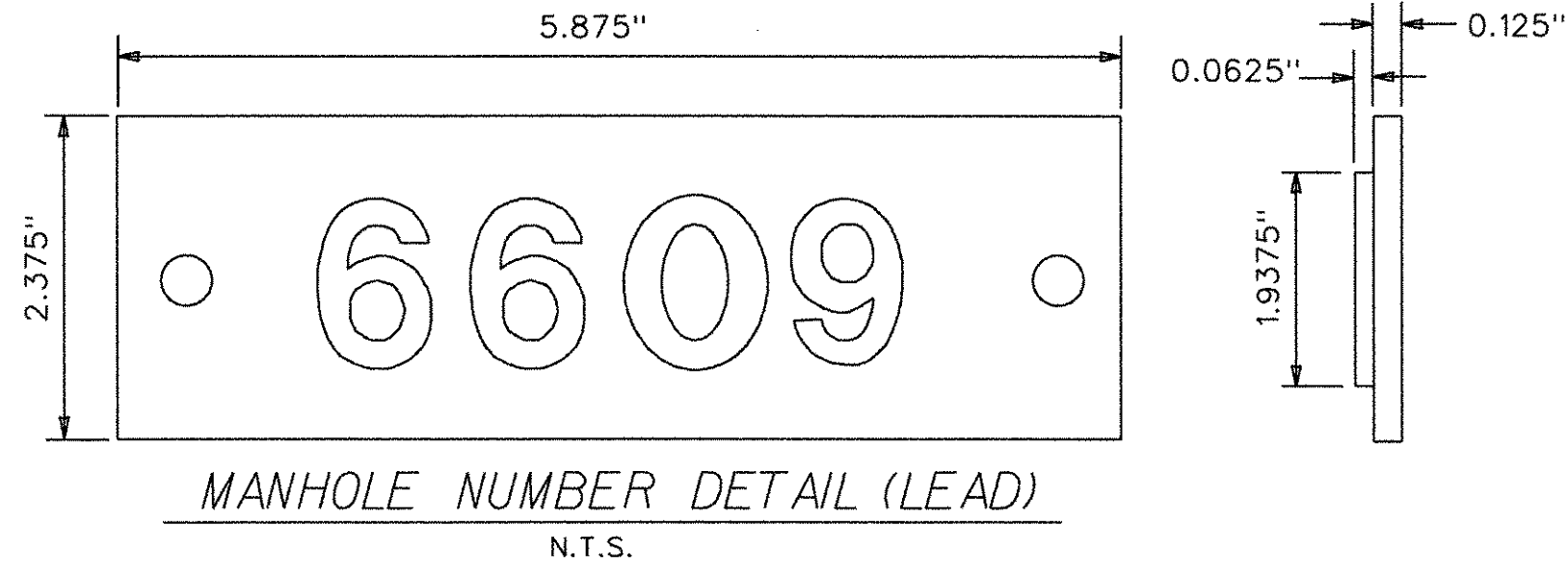

NOTE:

- CABLE RACKS SHALL BE GALV. AFTER FAB. IN ACCORDANCE WITH ASTM A-123.
- CABLE ARMS SHALL BE GALV. AFTER FAB. IN ACCORDANCE WITH ASTM A-153 53.
- ARMS MUST FIT ON INSIDE & OUTSIDE OF RACKS & MUST ALLOW INSULATOR TO FIT LOOSELY.
- USE 0.5" GALV. SUPPORTING BOLTS AND EXPANSION ANCHORS.

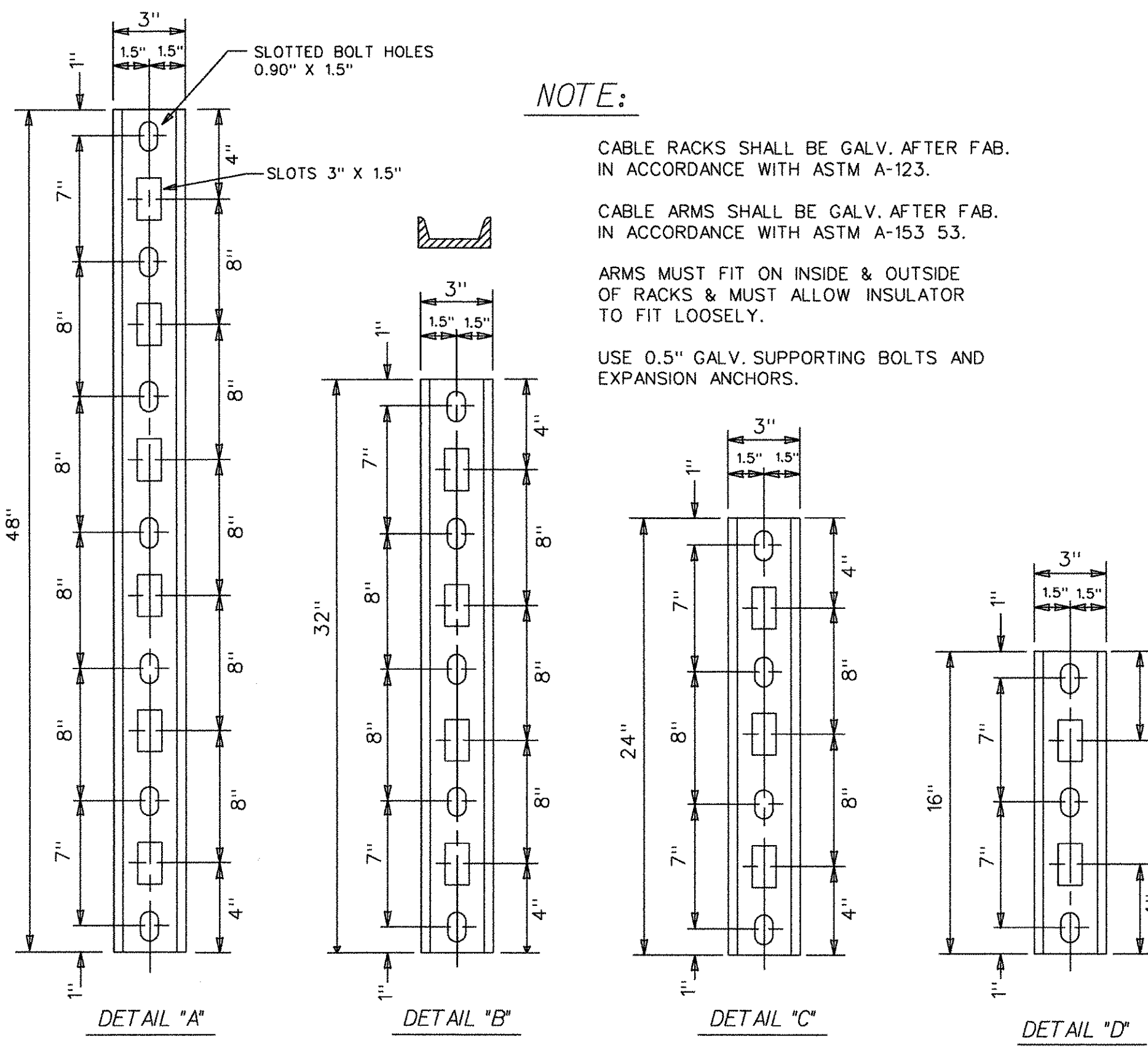

CABLE RACKS
76mm (3") STD. 4.1" CHANNEL
N.T.S.

SCALE: AS SHOWN

REVISIONS		
Date	Description	Chkd. by

DETAILS
EAST GRAND BOULEVARD BRIDGE

FOUR-WAY MANHOLE



Checked by _____ Approved by _____

PUBLIC LIGHTING DEPARTMENT
CITY OF DETROIT

Checked by _____ Approved by _____ File No. 51-0686

Designed by C.E.A. Checked by _____ Sheet No. 47 of 60

Disk File Name 106PLDM Job File No. CEA 138200

Date 3-03-08 Dwg. No. DTL-2-

REVISION DATE: APRIL 1, 2001 Computer File: T:\138200 E. Grand Blvd Bridge\DETAILS\106pldm.dgn DATE PLOTTED: 3/20/2008 TIME: 2:42:58 PM

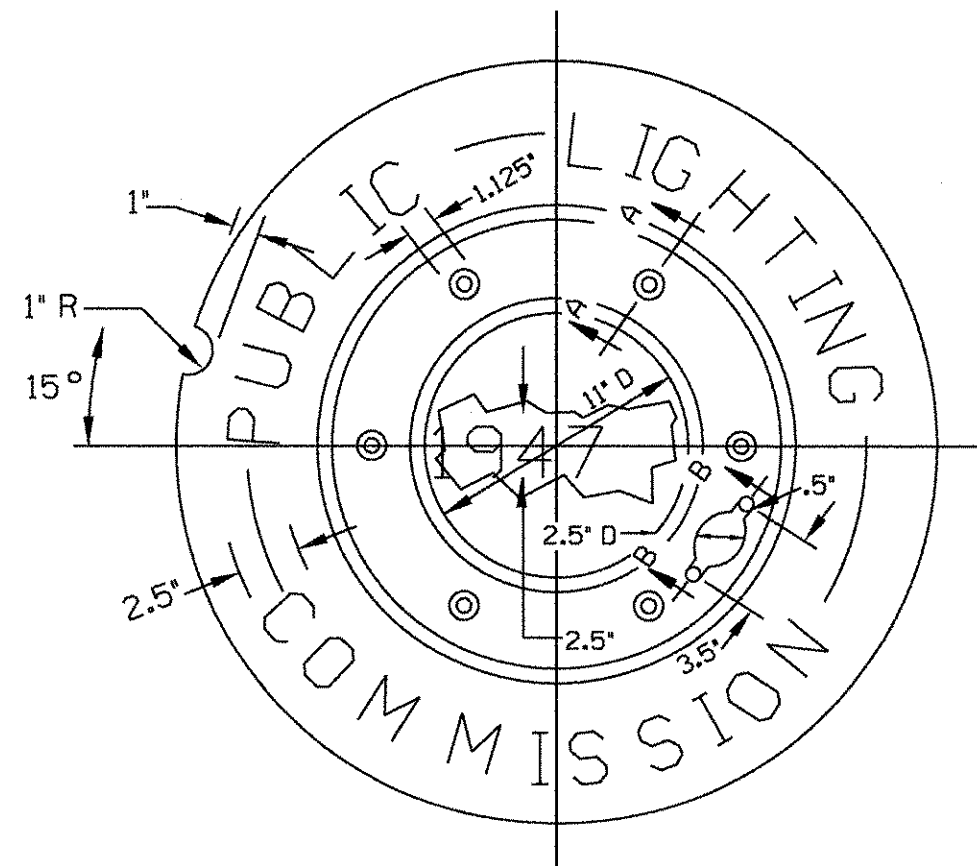

LETTERING & BEAD RAISED .375" ABOVE FACE.
YEAR ON COVER TO BE YEAR OF CASTING.
CONTRACTOR TO CHANGE PATTERN IF REQUIRED.

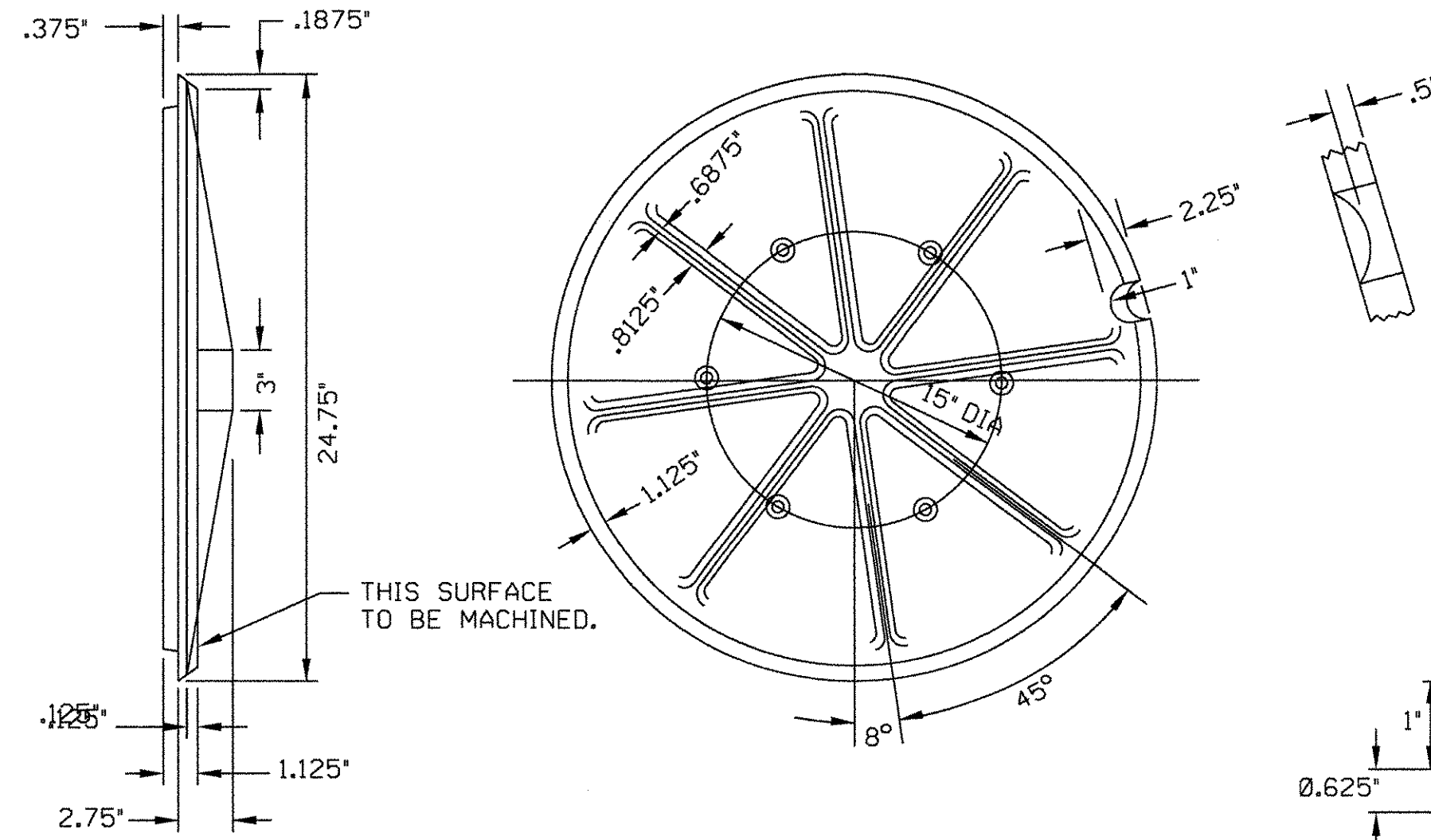

A.S.T.M. CLASS 30 GREY IRON
P.L.C. PATT. NO. 418 APPROX.
WT. 111kg(245lb)

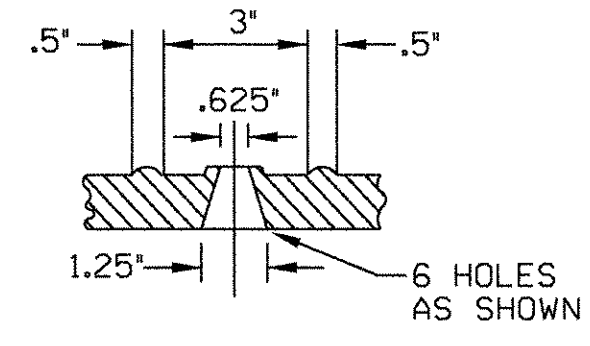

SECTION A-A
N.T.S.

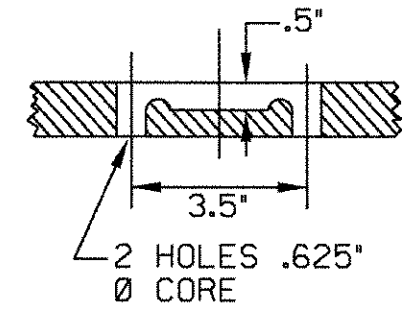

SECTION B-B
N.T.S.

MANHOLE COVER
N.T.S.

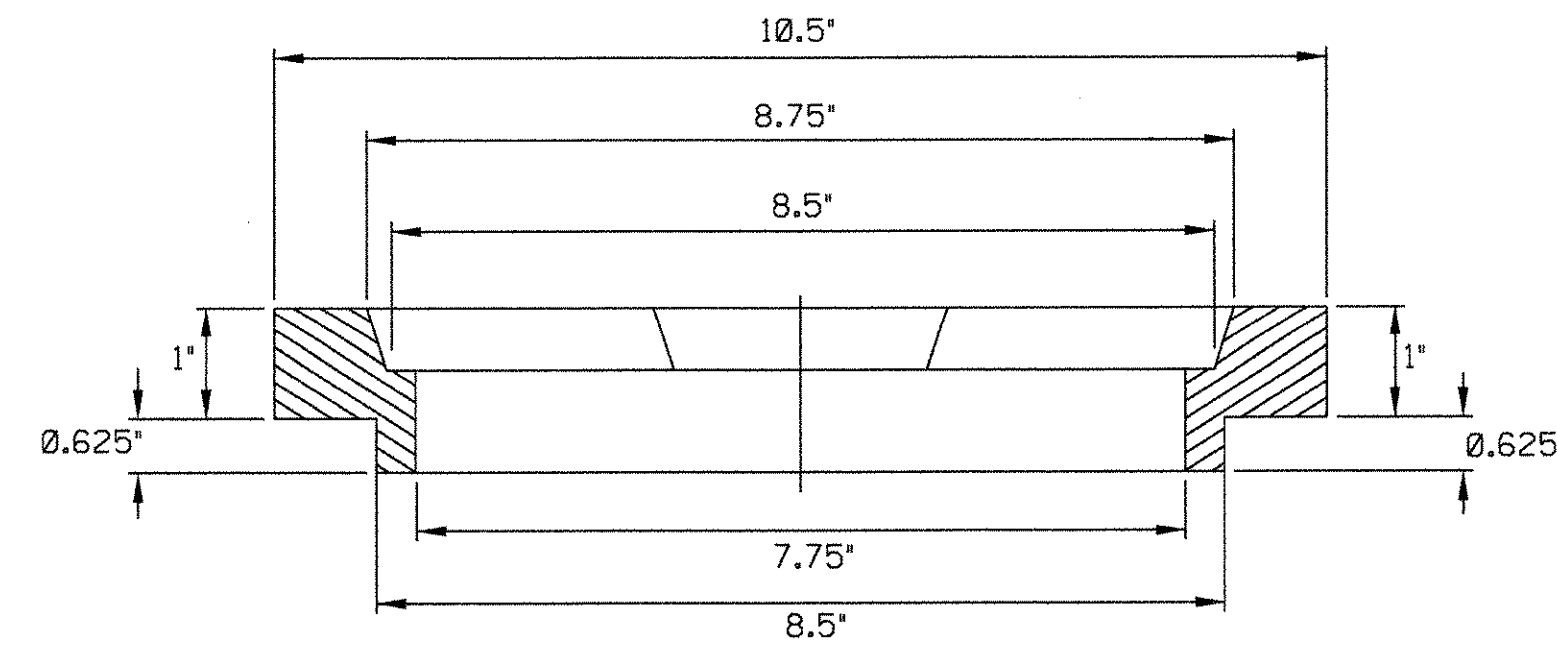

SECTION D-D
N.T.S.

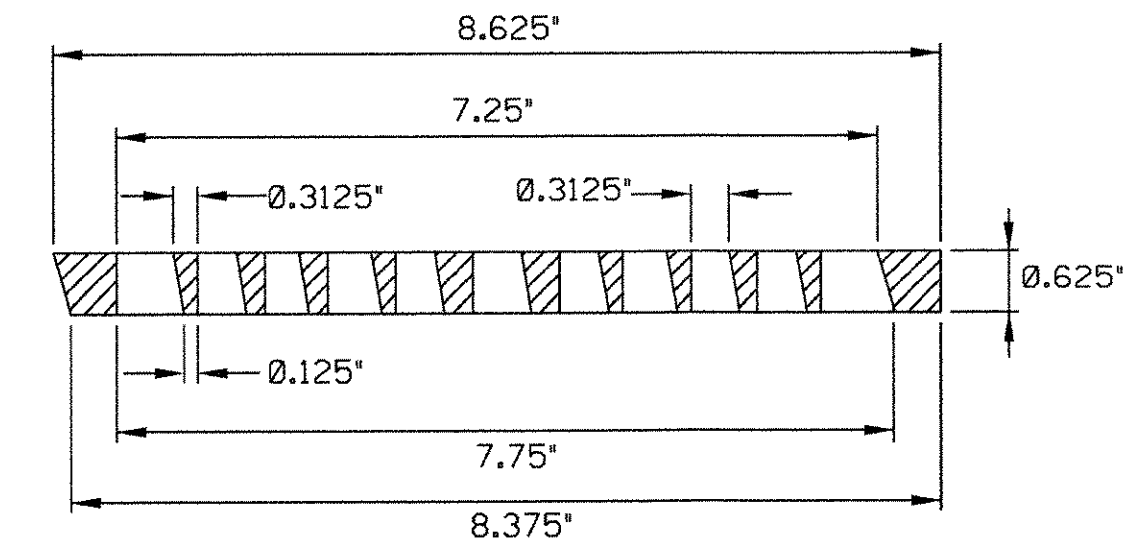

SECTION E-E
N.T.S.

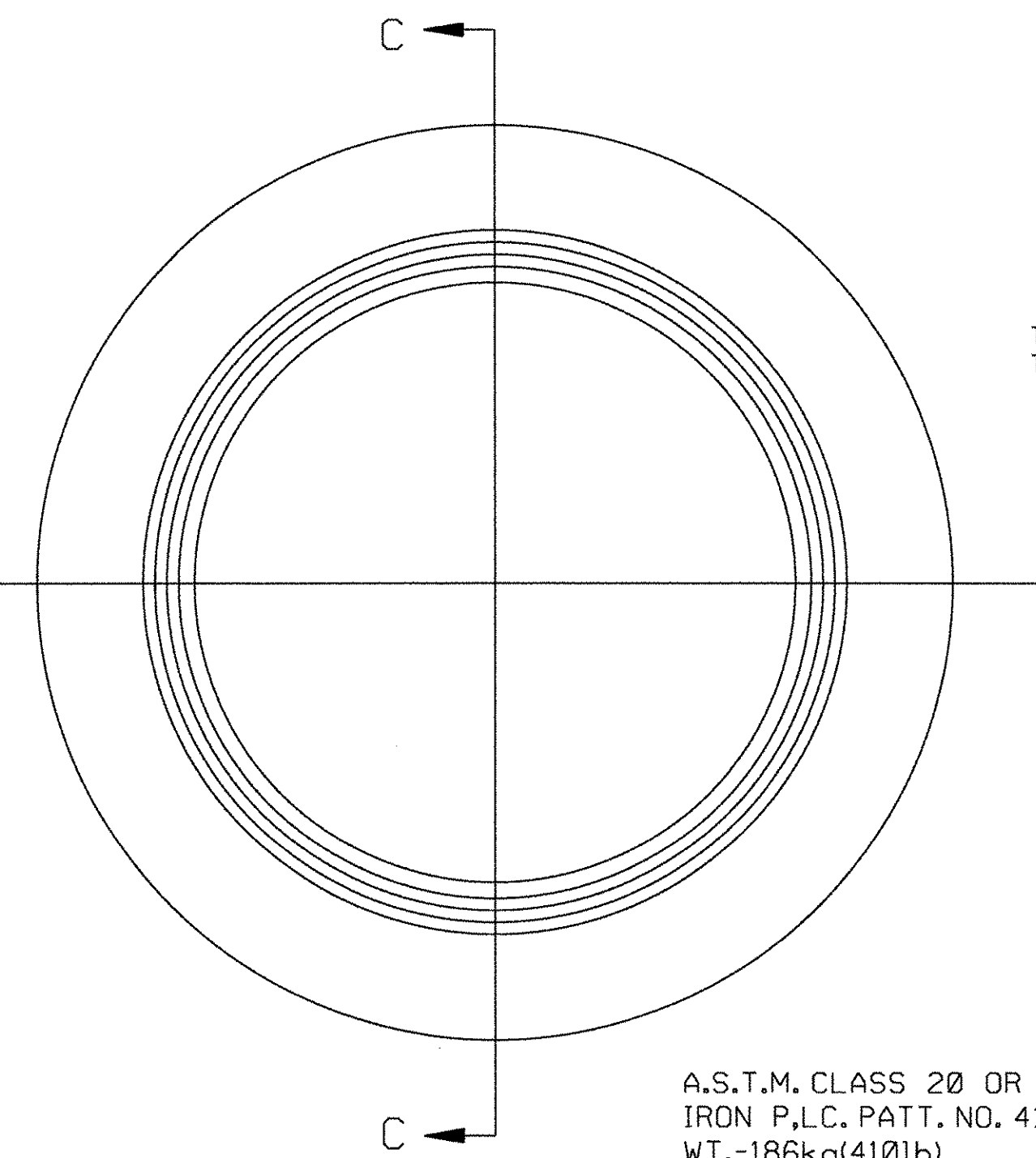

A.S.T.M. CLASS 20 OR 30 GREY
IRON P.L.C. PATT. NO. 417 APPROX.
WT. -186kg(410lb)

MANHOLE FRAME
N.T.S.

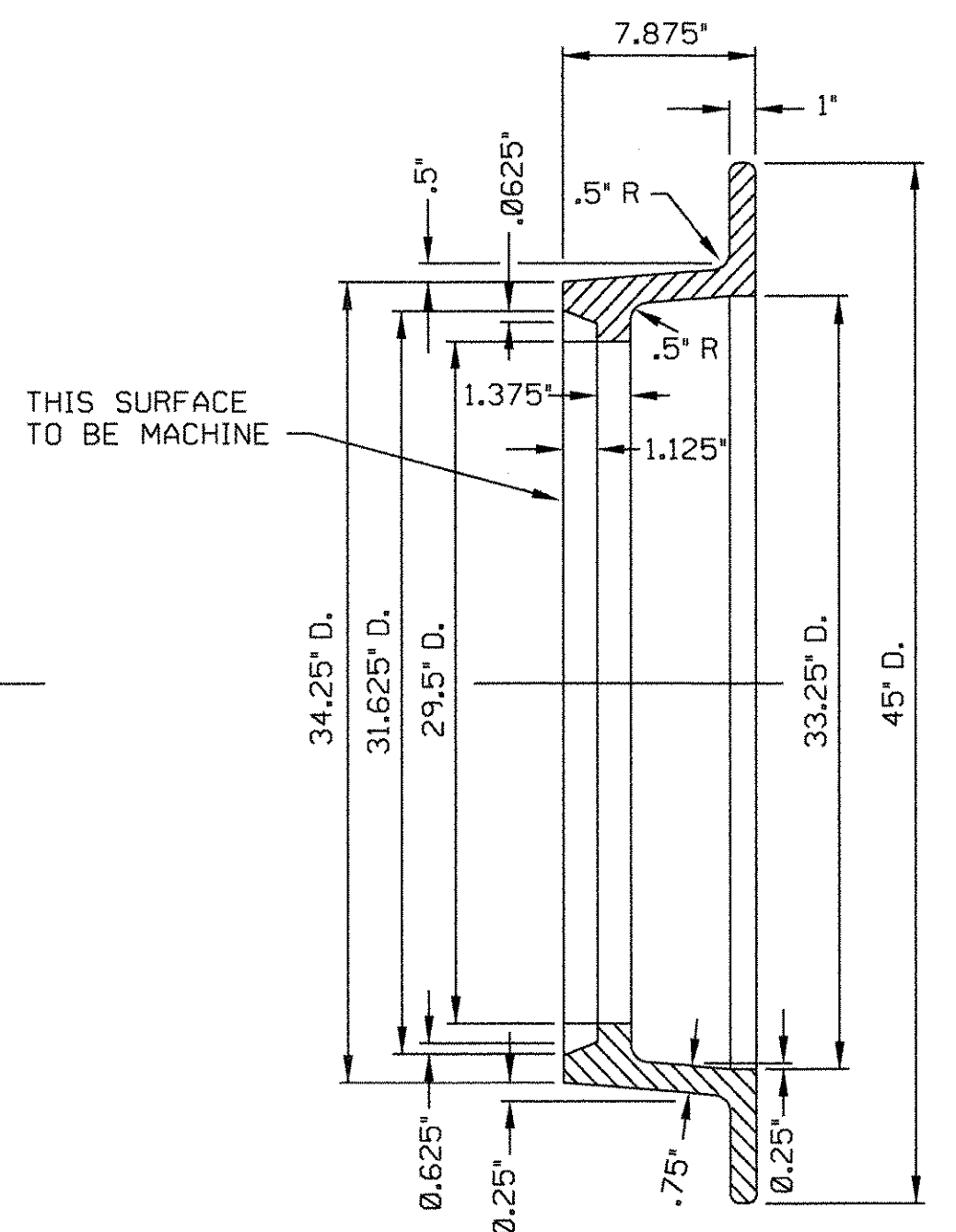

SECTION "C-C"
N.T.S.

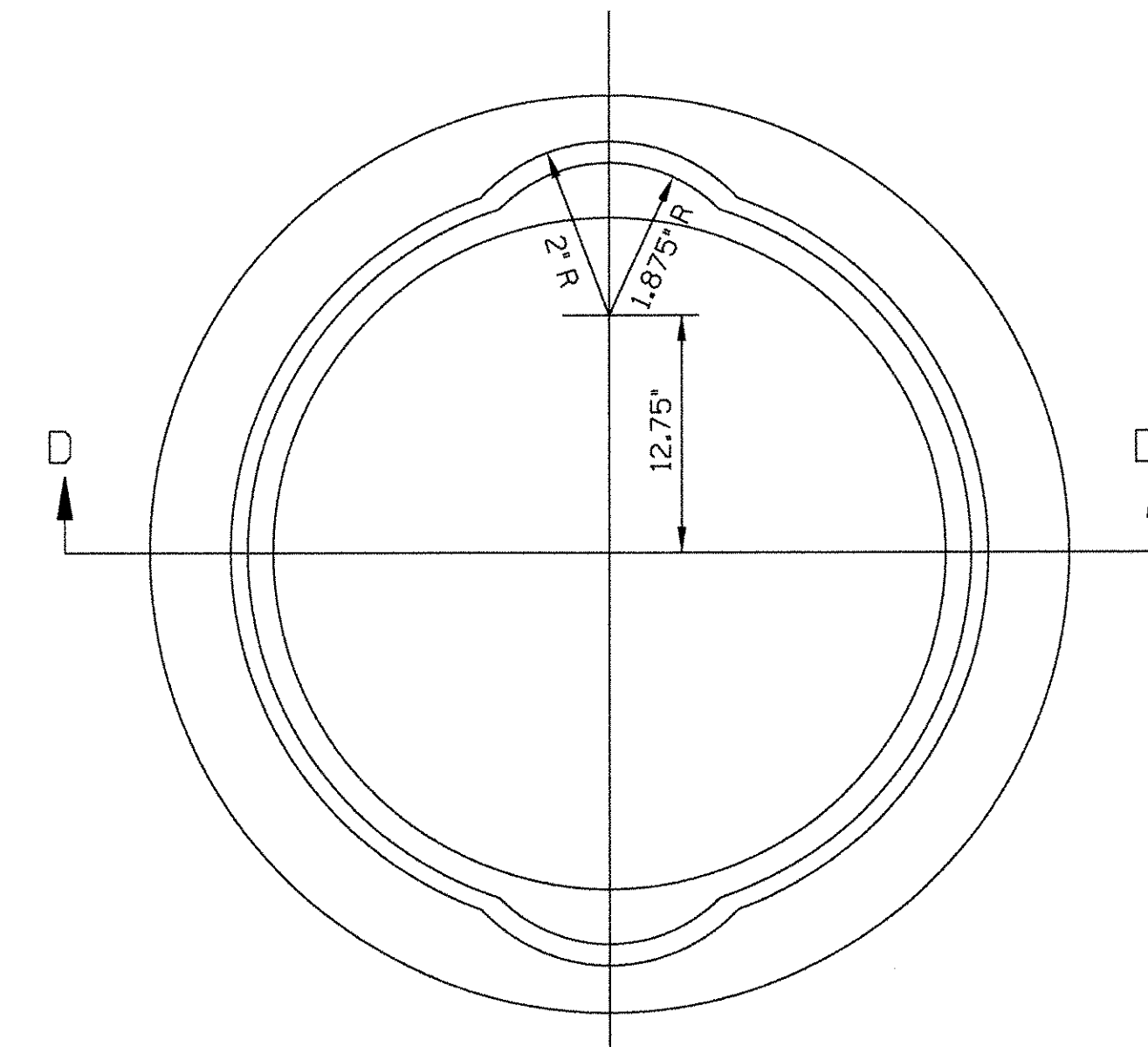

A.S.T.M. CLASS 20 OR 30 GREY
IRON P.L.C. PATT. NO. 318-A
APPROX WT-4.081b(91b)

SEWER RING
N.T.S.

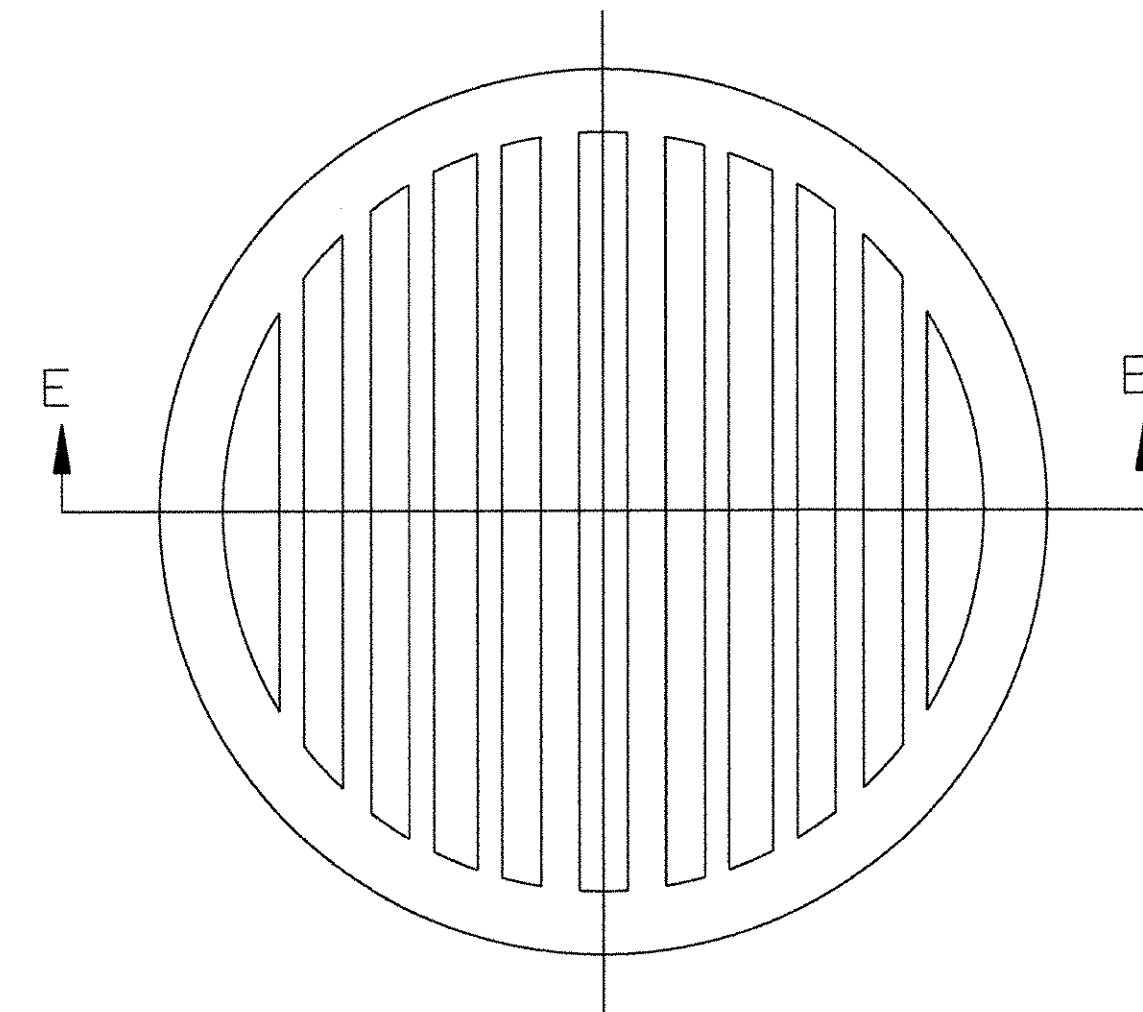

A.S.T.M. CLASS 20 OR 30 GREY
IRON P.L.C. PATT. NO. 318
APPROX WT-2.041b(4.51b)

SEWER GRATE
N.T.S.

SCALE: AS SHOWN

REVISIONS		
Date	Description	Chkd. by

DETAILS
EAST GRAND
BOULEVARD BRIDGE

MANHOLE FRAMES & COVERS
- SEWER GRATE & RING



Checked by _____ Approved by _____

**PUBLIC LIGHTING
DEPARTMENT**



Checked by _____ Approved by _____ File No. 51-0686

Consulting
Engineering
Associates, Inc.
16580 WYOMING AVE. DETROIT MICHIGAN 48221
TELEPHONE: (313) 341-5797 FAX: 341-0205

Designed by C.E.A. Checked by _____ Sheet No. 48 of 60

Disk File Name 108PLDM Job File No. CEA 138200
Date 3-03-08 Dwg. No. DTL-2-

REVISION DATE: APRIL 1, 2001
Computer File: T:\138200 E. Grand Blvd Bridge\DETAILS\108plde.dgn
DATE PLOTTED: 3/20/2008
TIME: 2:43:39 PM

TIME: 2:44:11 PM
 DATE PLOTTED: 3/20/2008
 REVISION DATE: APRIL 1, 2001
 Computer File: T:\138200 E. Grand Blvd Bridge\DETAILS\114plde.dgn

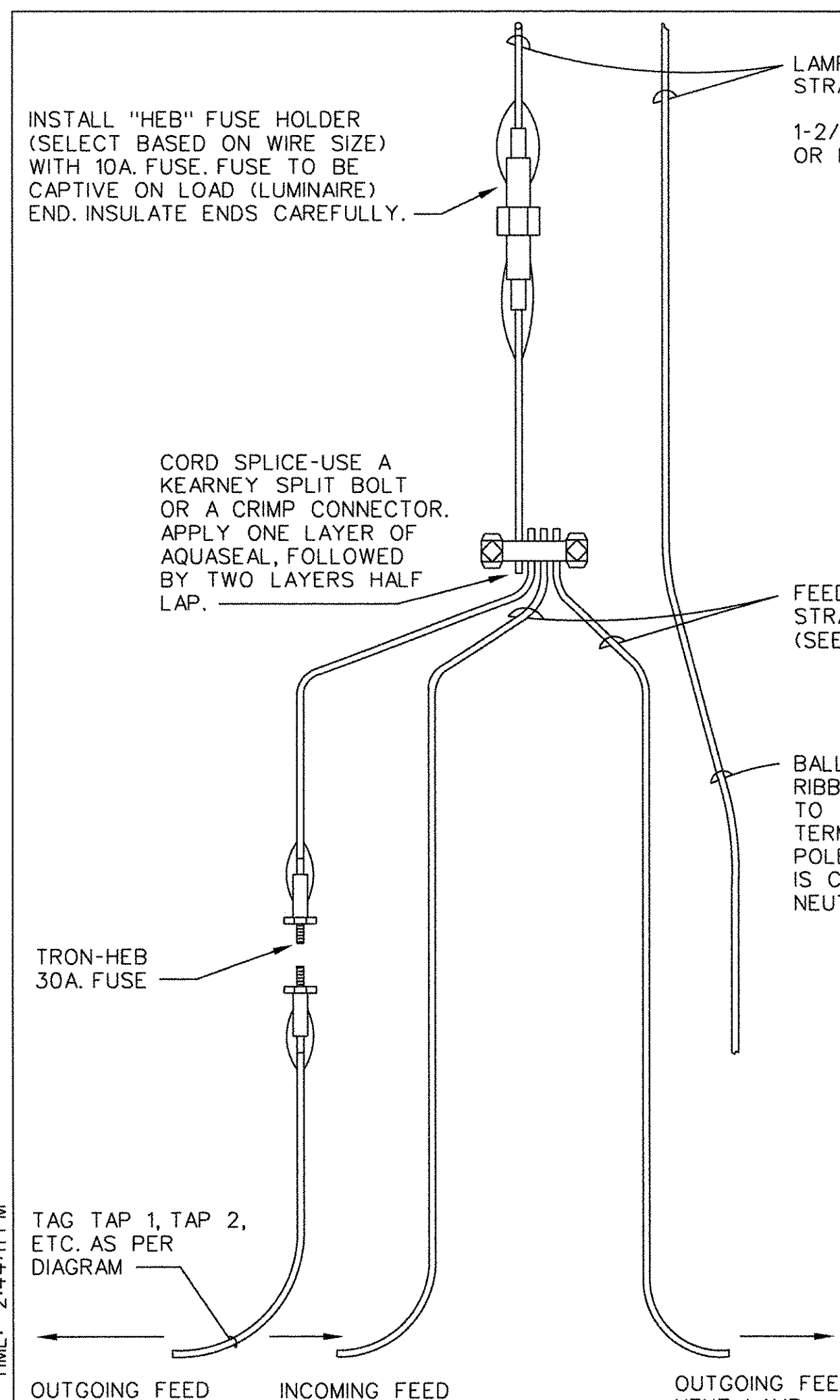

MULTIPLE STREET LIGHTING CONNECTION IN POLE BASE
N.T.S.

TYPE	POLE DIAMETER
A	3.6"-4.5"
B	6.1"-6.9"
C	7.5"-8.5"

CLAMP SIZE TABLE

TRAFFIC SIGNAL SECONDARY OR MULTIPLE STREET LIGHTING CABLE DETAIL OF SEALING OF CABLE END
N.T.S.

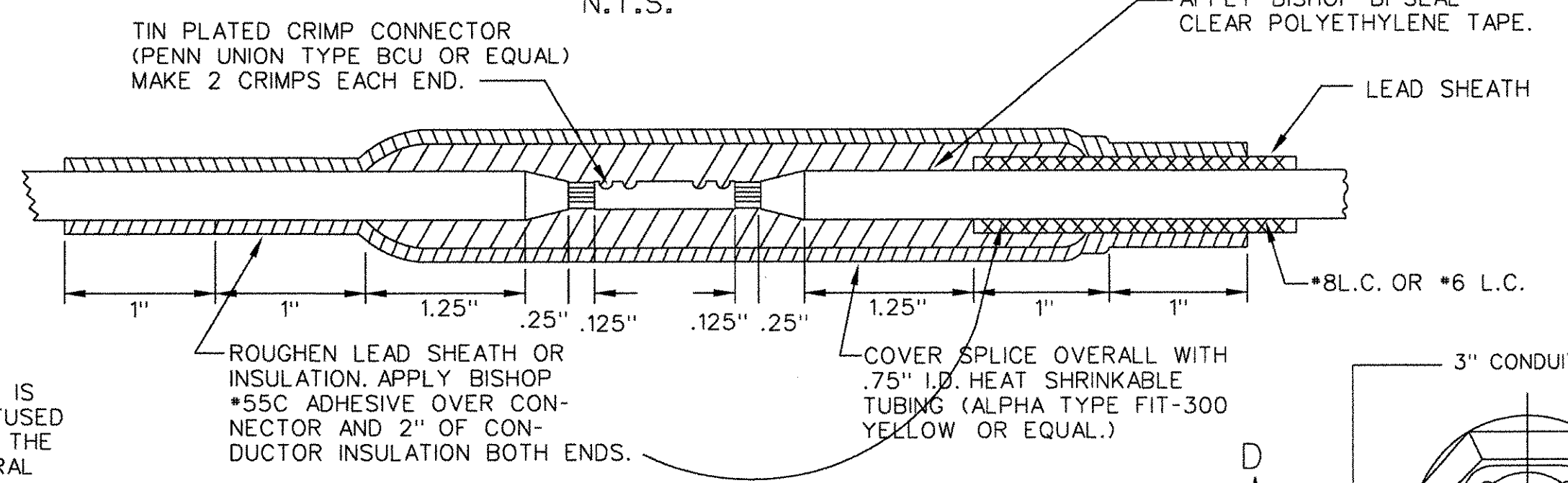

TRAFFIC SIGNAL SECONDARY OR MULTIPLE STREET LIGHTING SPLICE DETAIL "A"
N.T.S.

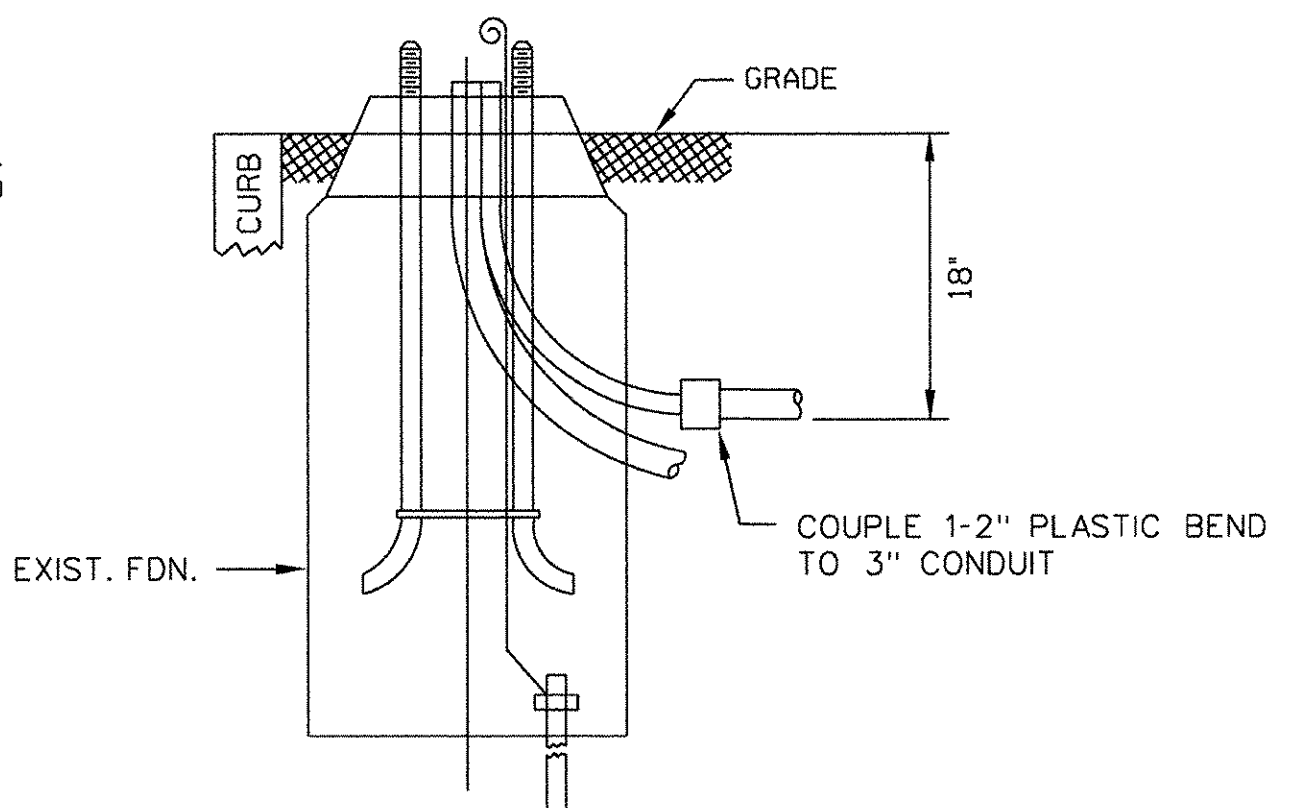
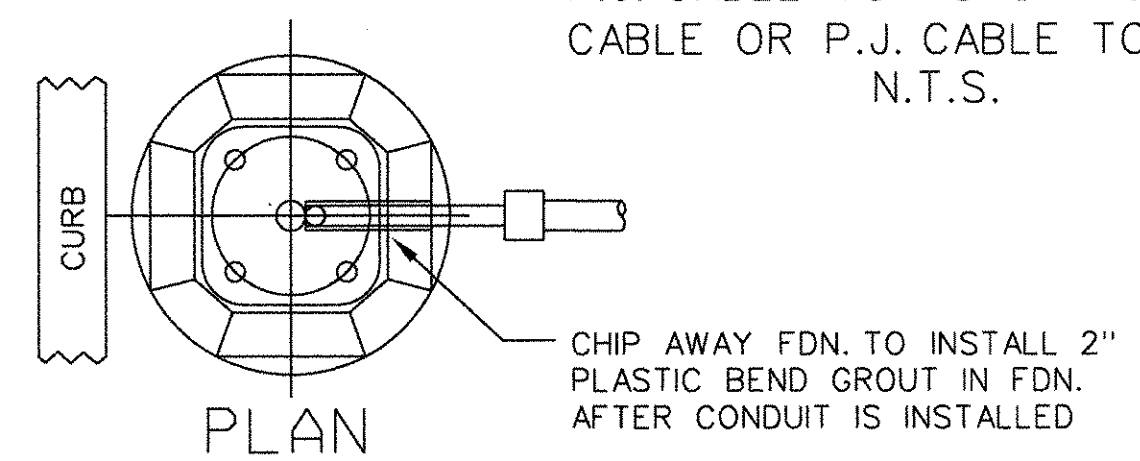

DETAIL OF INSTALLING CONDUITS INTO EXISTING FDN.
N.T.S.

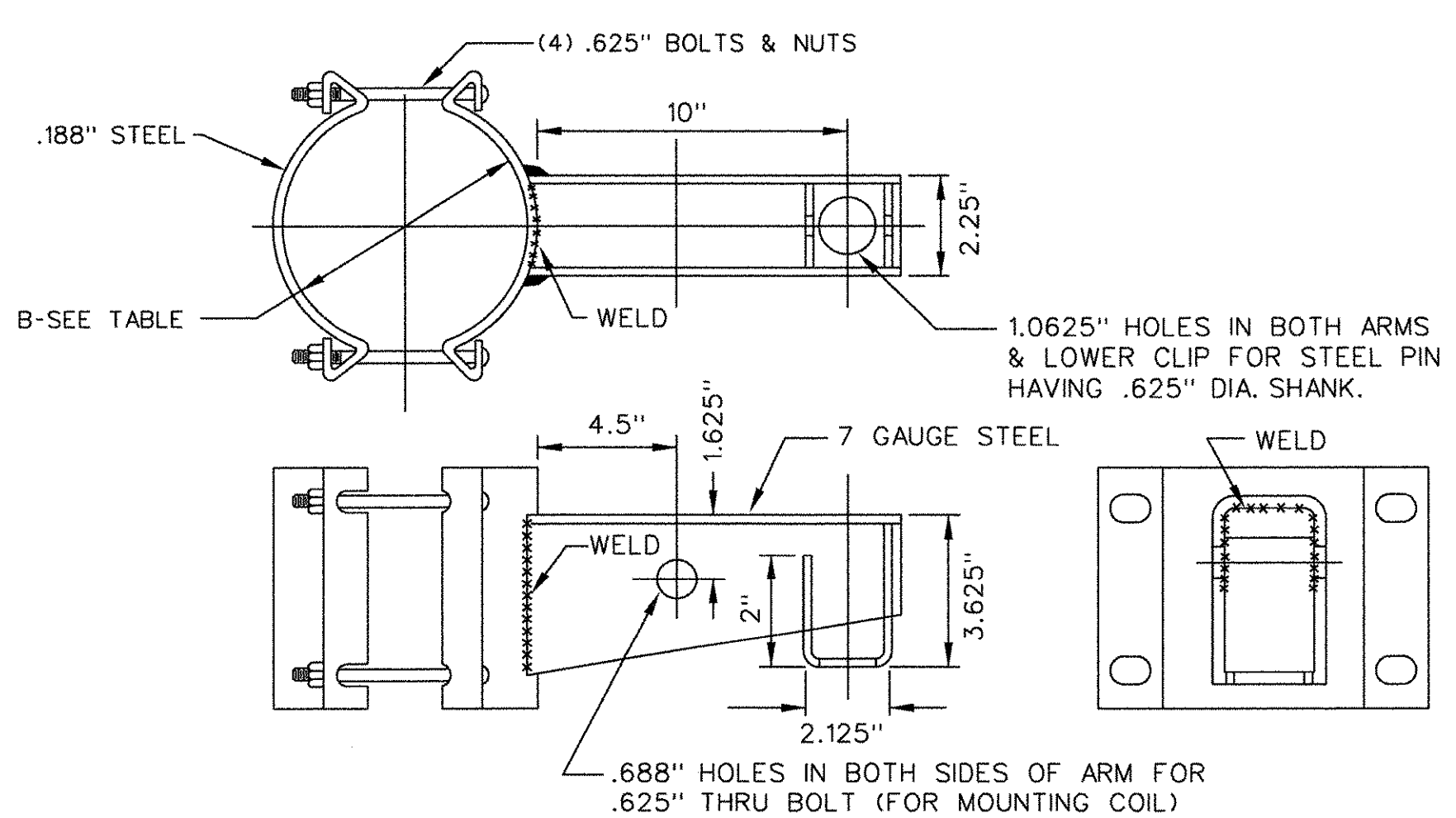

CLAMP FEEDER ARM
N.T.S.

* FINISH SHALL BE HOT DIP GALVANIZED AFTER FABRICATION

GROUND CONNECTION
N.T.S.

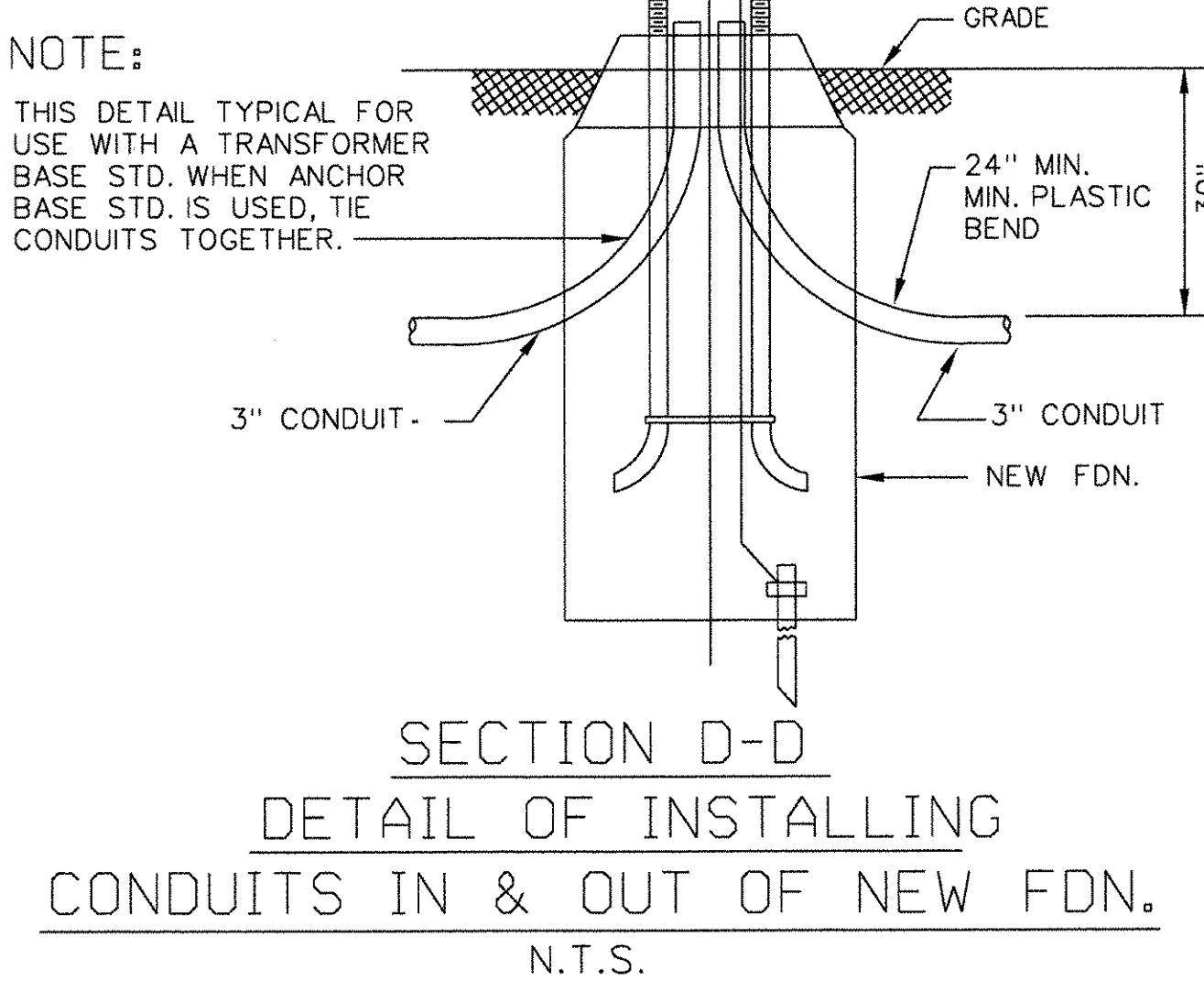
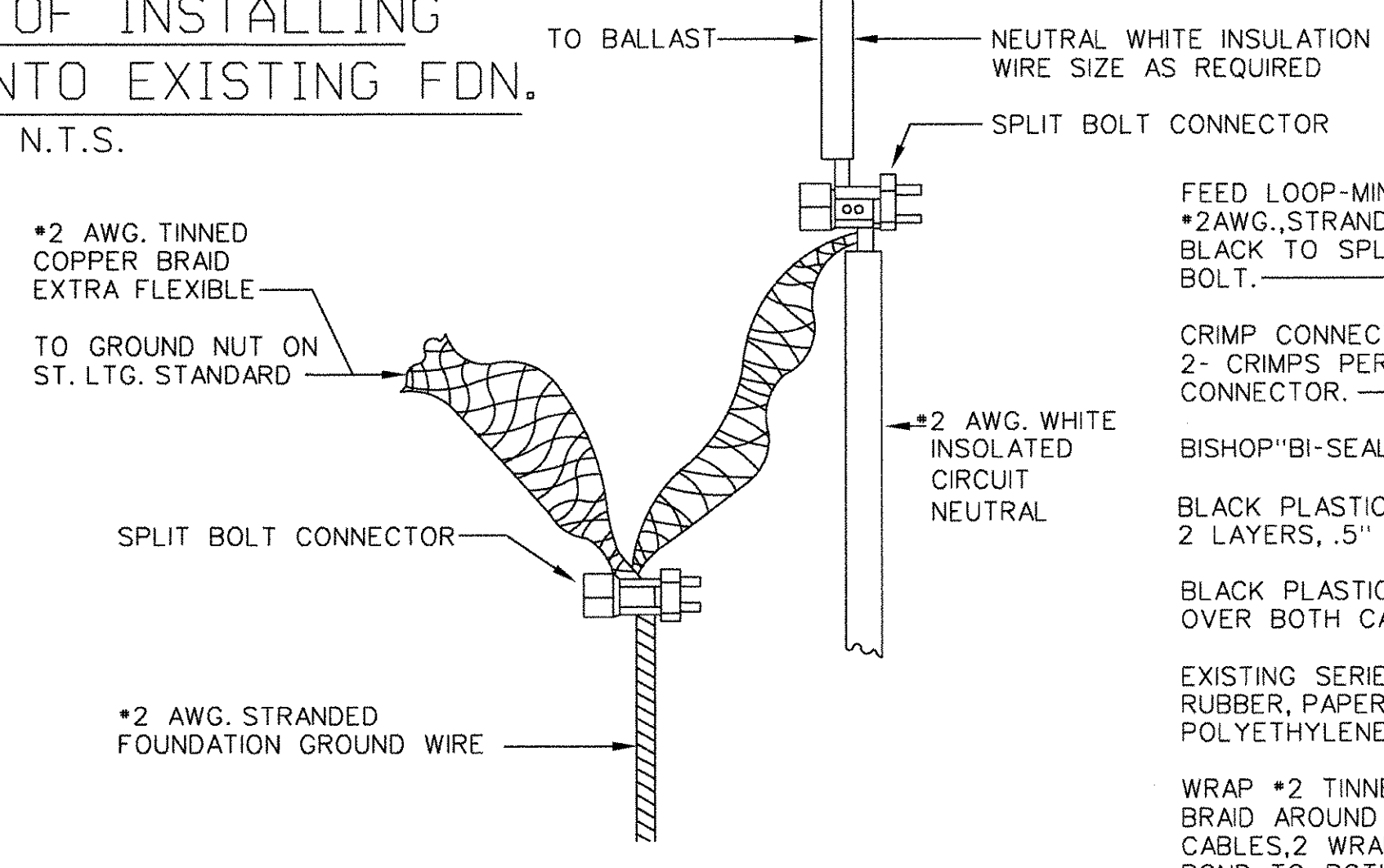

SECTION D-D DETAIL OF INSTALLING CONDUITS IN & OUT OF NEW FDN.
N.T.S.

SERIES-TO-MULTIPLE LIGHTING CONVERSION POLE BASE CONNECTIONS
N.T.S.

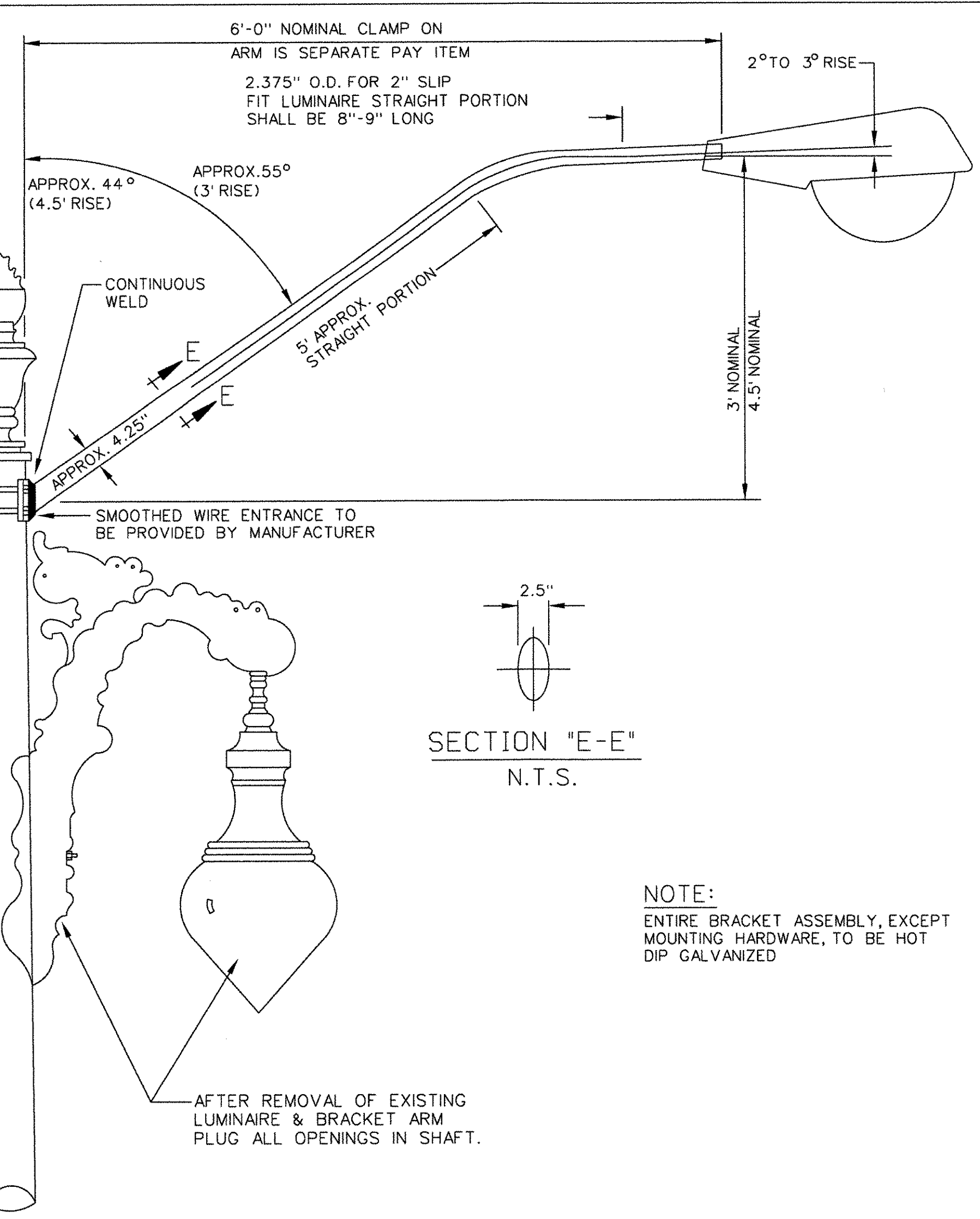
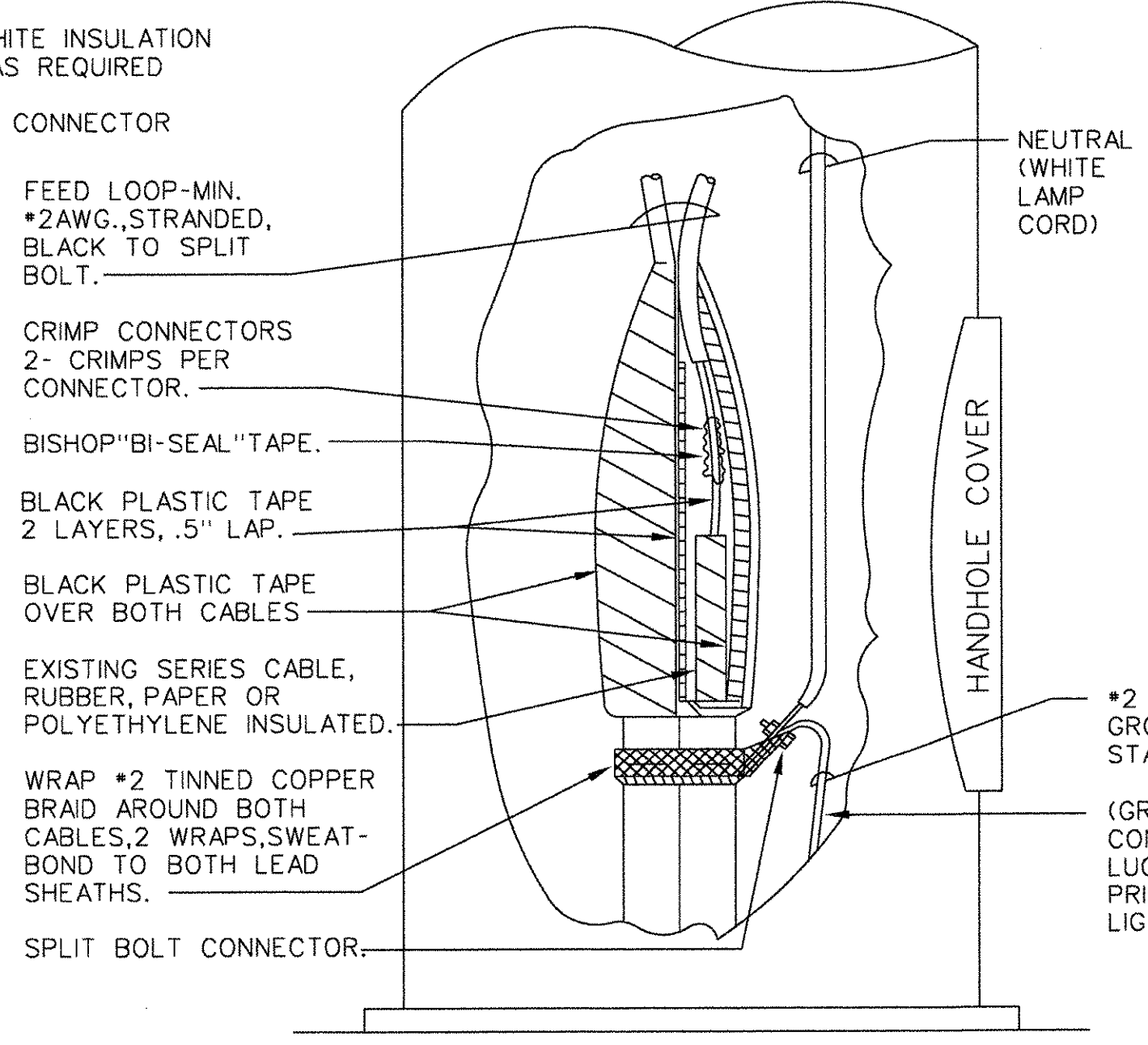

CLAMP ON BRACKET ARM ELEVATION
N.T.S.

NOTE: ENTIRE BRACKET ASSEMBLY, EXCEPT MOUNTING HARDWARE, TO BE HOT DIP GALVANIZED

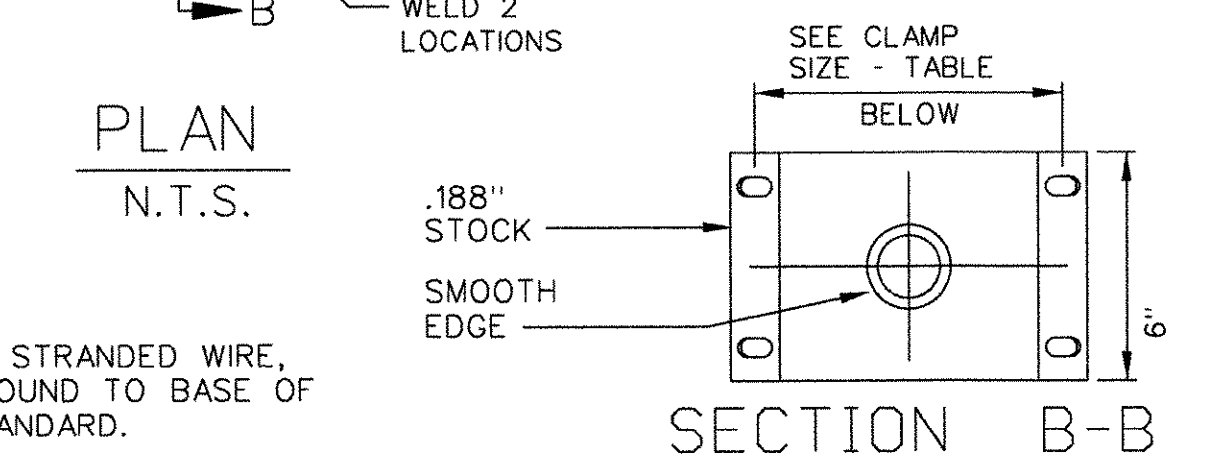
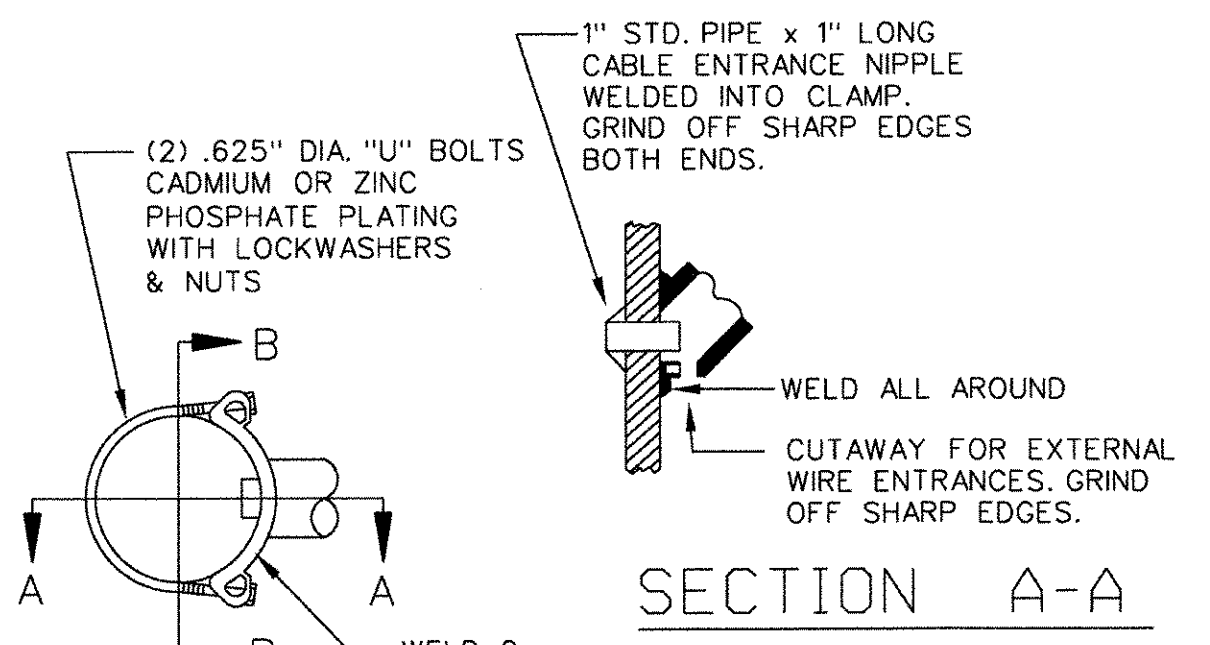

CLAMP SIZE TABLE

TYPE	POLE DIAMETER
A	3.6"-4.5"
B	6.1"-6.9"
C	7.5"-8.5"

PIPE CLAMP DETAILS
N.T.S.

SCALE: AS SHOWN

REVISIONS		
Date	Description	Chkd. by

DETAILS

EAST GRAND BOULEVARD BRIDGE

MULT. ST. LTG. CABLE CONNECTIONS, CLAMP-ON ARM & MISC. DETAILS

DEPARTMENT OF PUBLIC WORKS

CITY OF DETROIT

Checked by _____ Approved by _____

PUBLIC LIGHTING DEPARTMENT

CITY OF DETROIT

Checked by _____ Approved by _____ File No. 51-0686

Consulting Engineering Associates, Inc.

16580 WYOMING AVE. DETROIT MICHIGAN 48221

TELEPHONE: (313) 341-5797 FAX: 341-0265

Designed by C.E.A. Checked by _____ Sheet No. 49 of 60

Disk File Name 114PLDM Job File No. CEA 138200

Date 3-03-08 Dwg. No. DTL-2-

REVISION DATE: APRIL 1, 2001
 Computer File: T:\138200 E. Grand Blvd Bridge\DETAILS\115plde.dgn
 DATE PLOTTED: 3/20/2008
 TIME: 2:45:56 PM

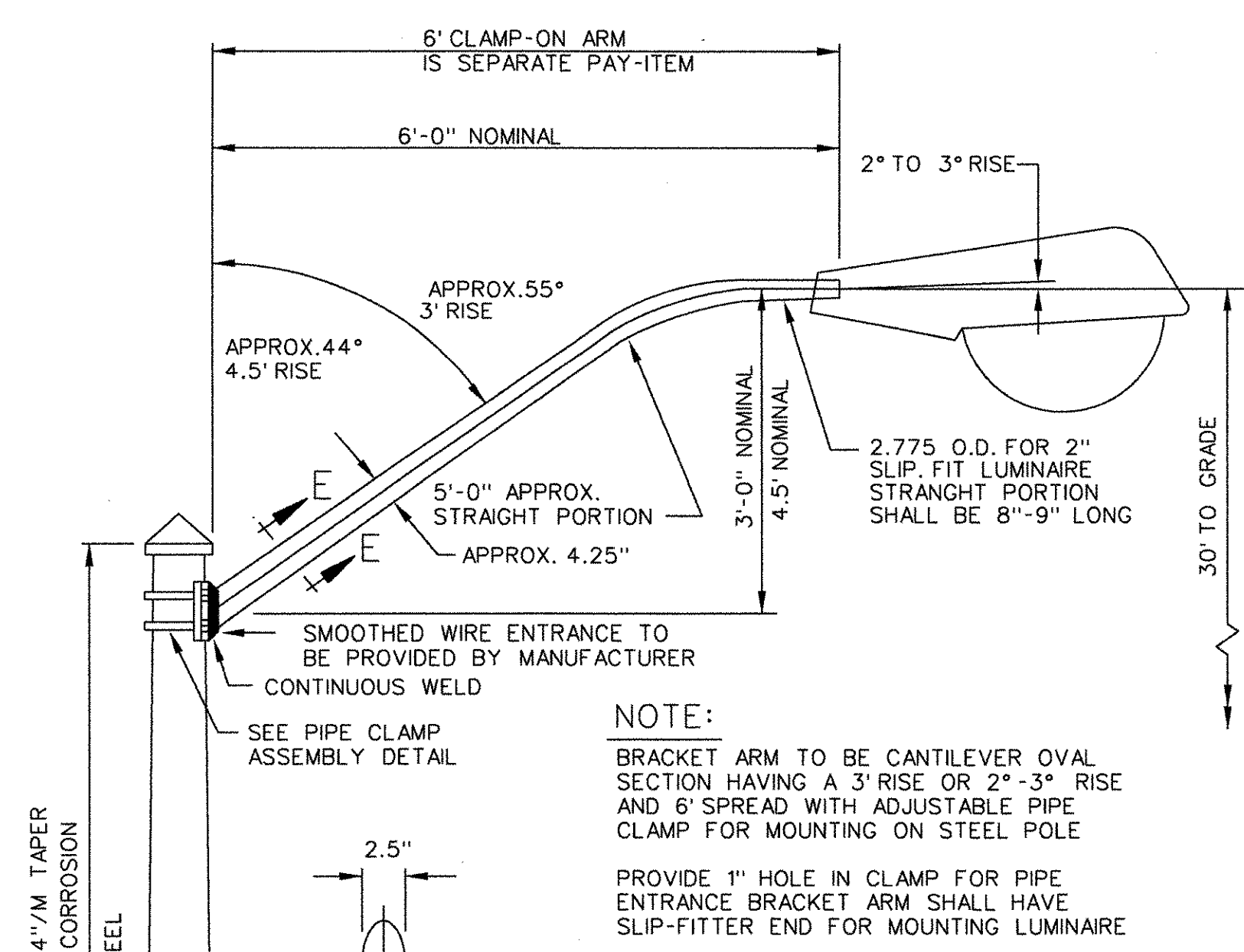

6 FT. CLAMP-ON BRACKET ARM
N.T.S.

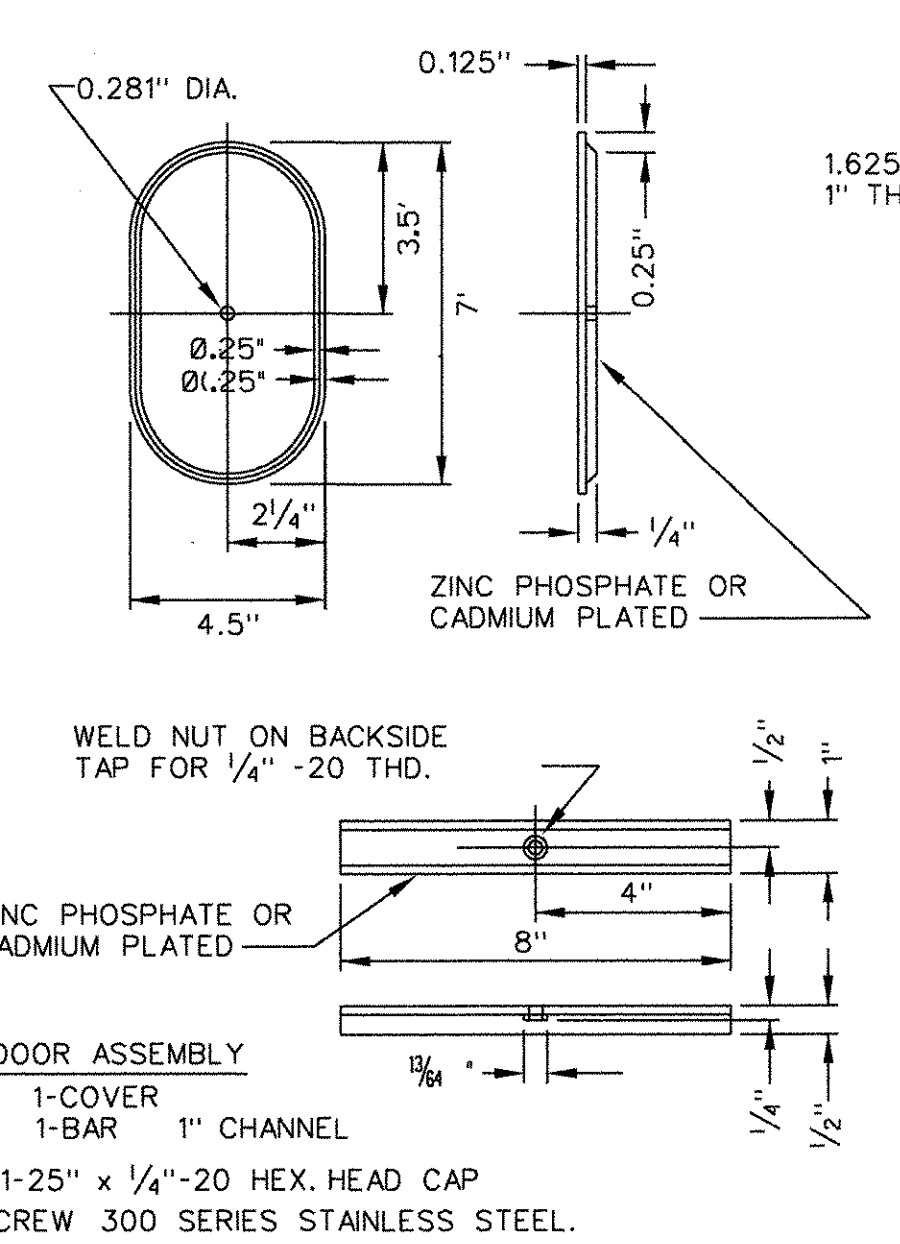

HANDHOLE COVER DETAIL
N.T.S.

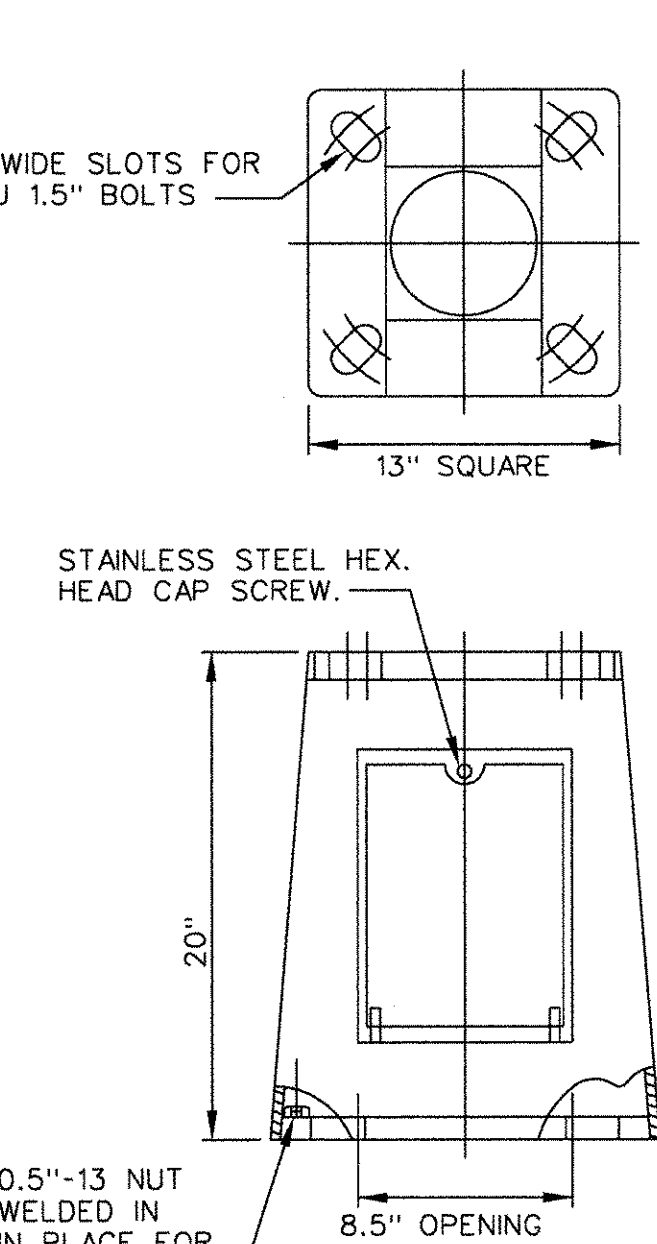

SPECIAL FDN. PLAN
N.T.S.

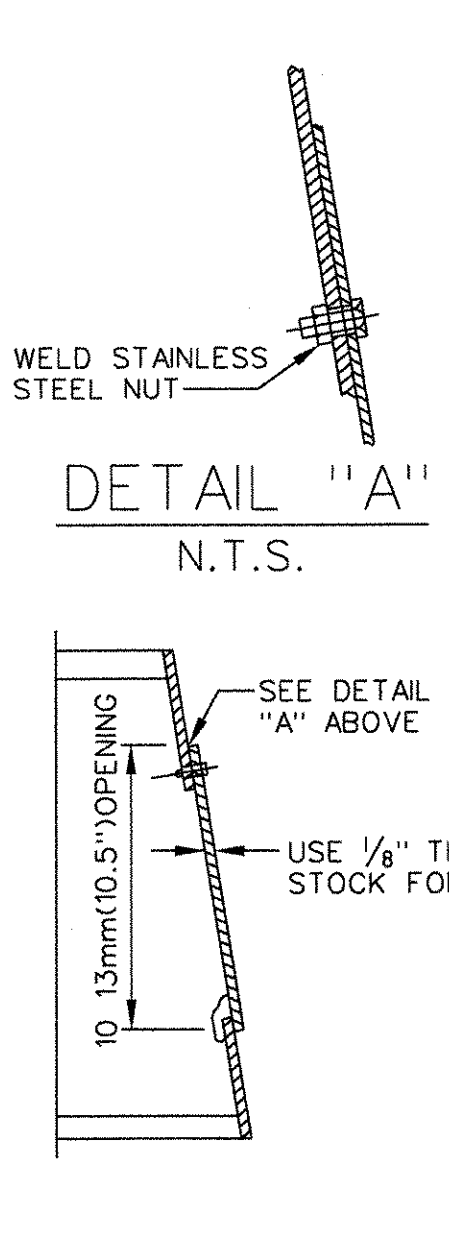

SPECIAL FOUNDATION
N.T.S.

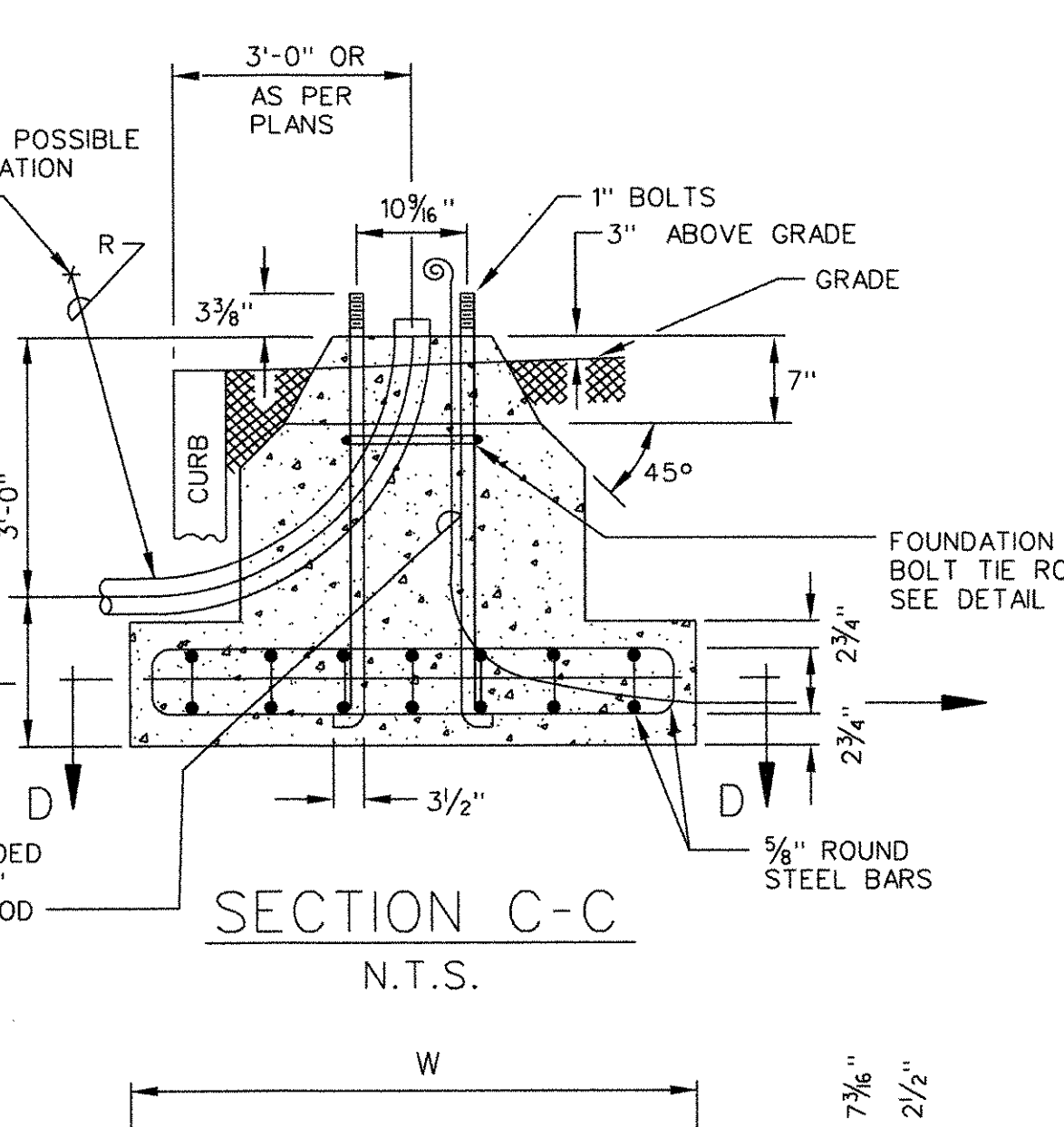

SECTION C-C
N.T.S.

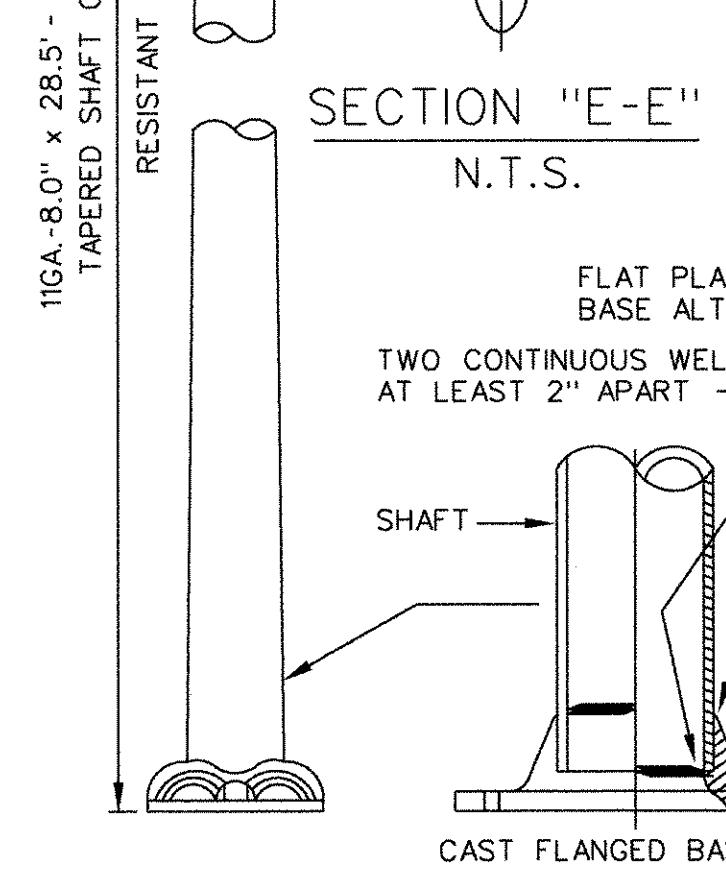

SECTION E-E
N.T.S.

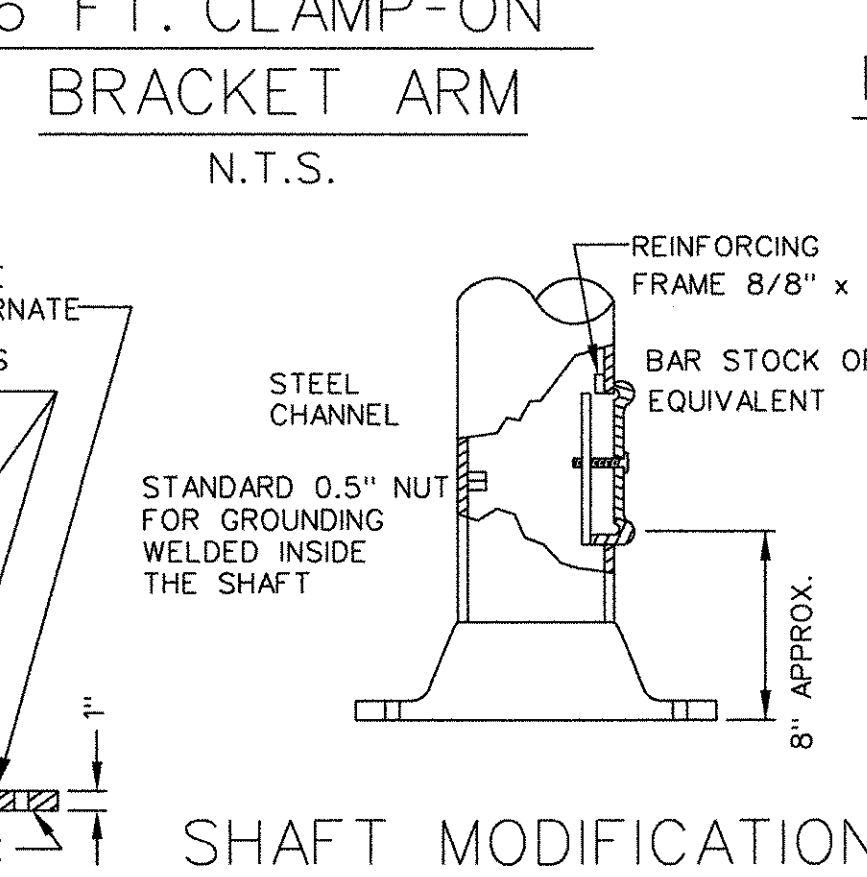

SHAFT MODIFICATION
N.T.S.

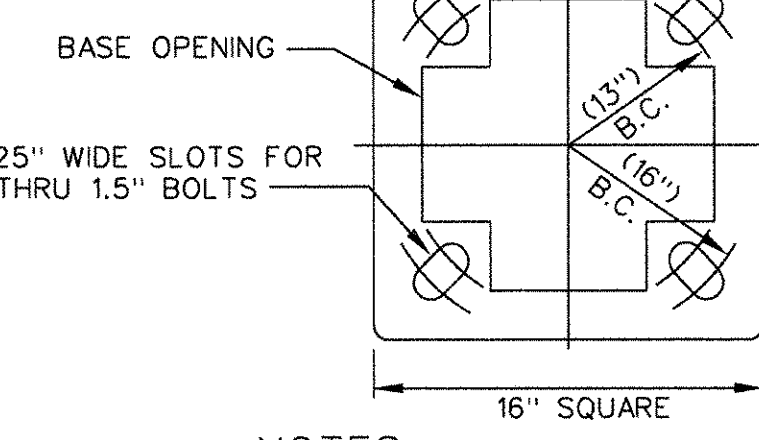
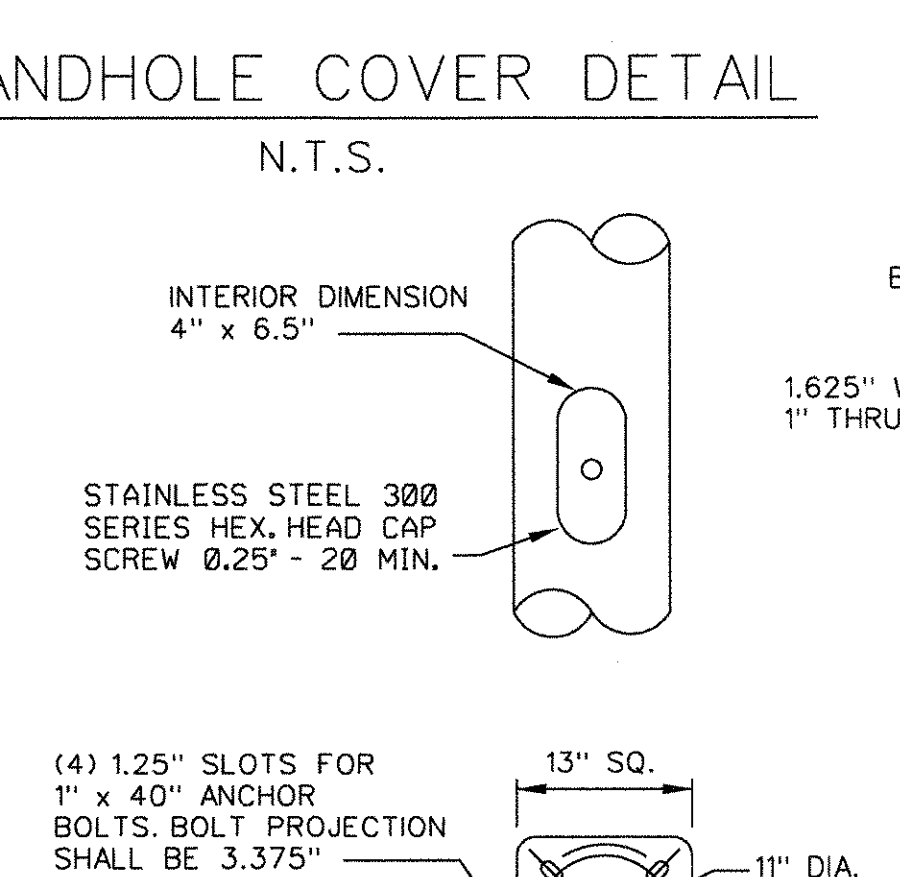

P.L.D. UNIVERSAL STEEL TRANSFORMER BASE
N.T.S.

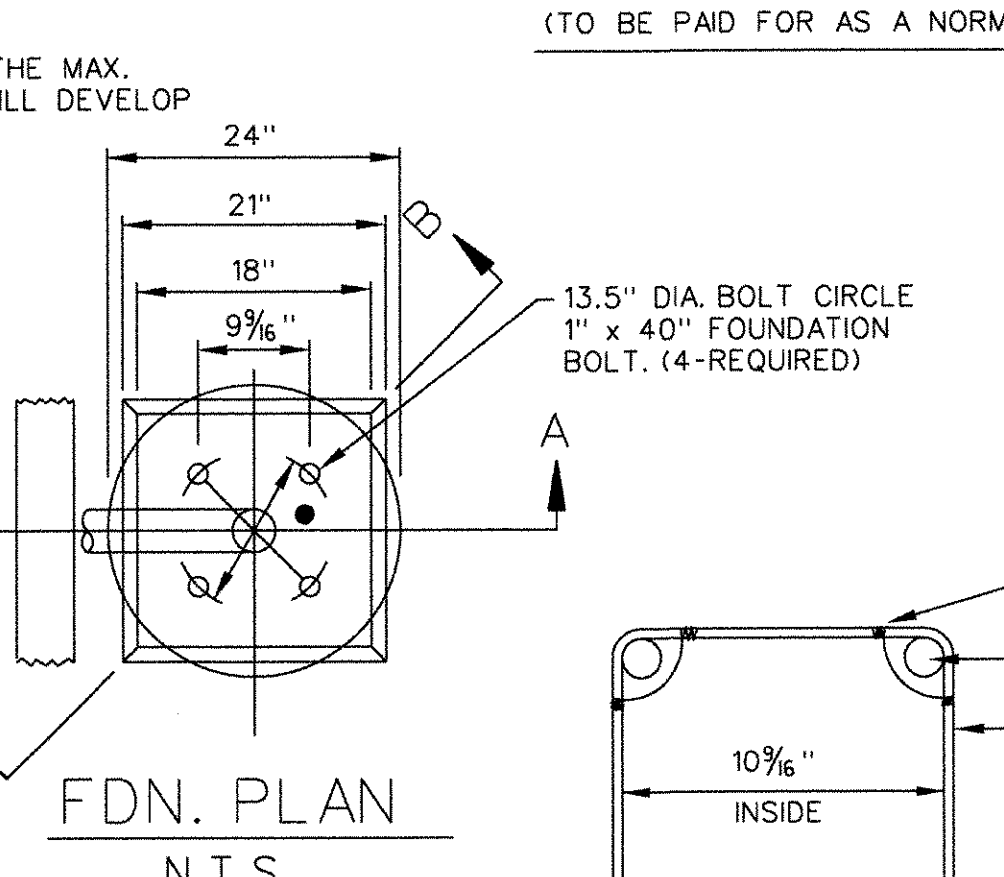

FDN. PLAN
N.T.S.

L	W	T
(5'-0")	(4'-3")	(1'-0")
(4'-6")	(3'-7")	(1'-6")

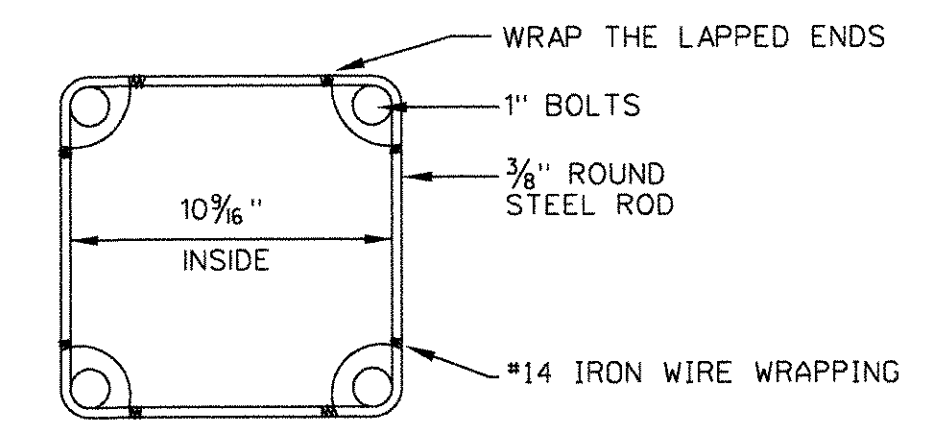

DETAIL C
FDN. BOLT TIE ROD
N.T.S.

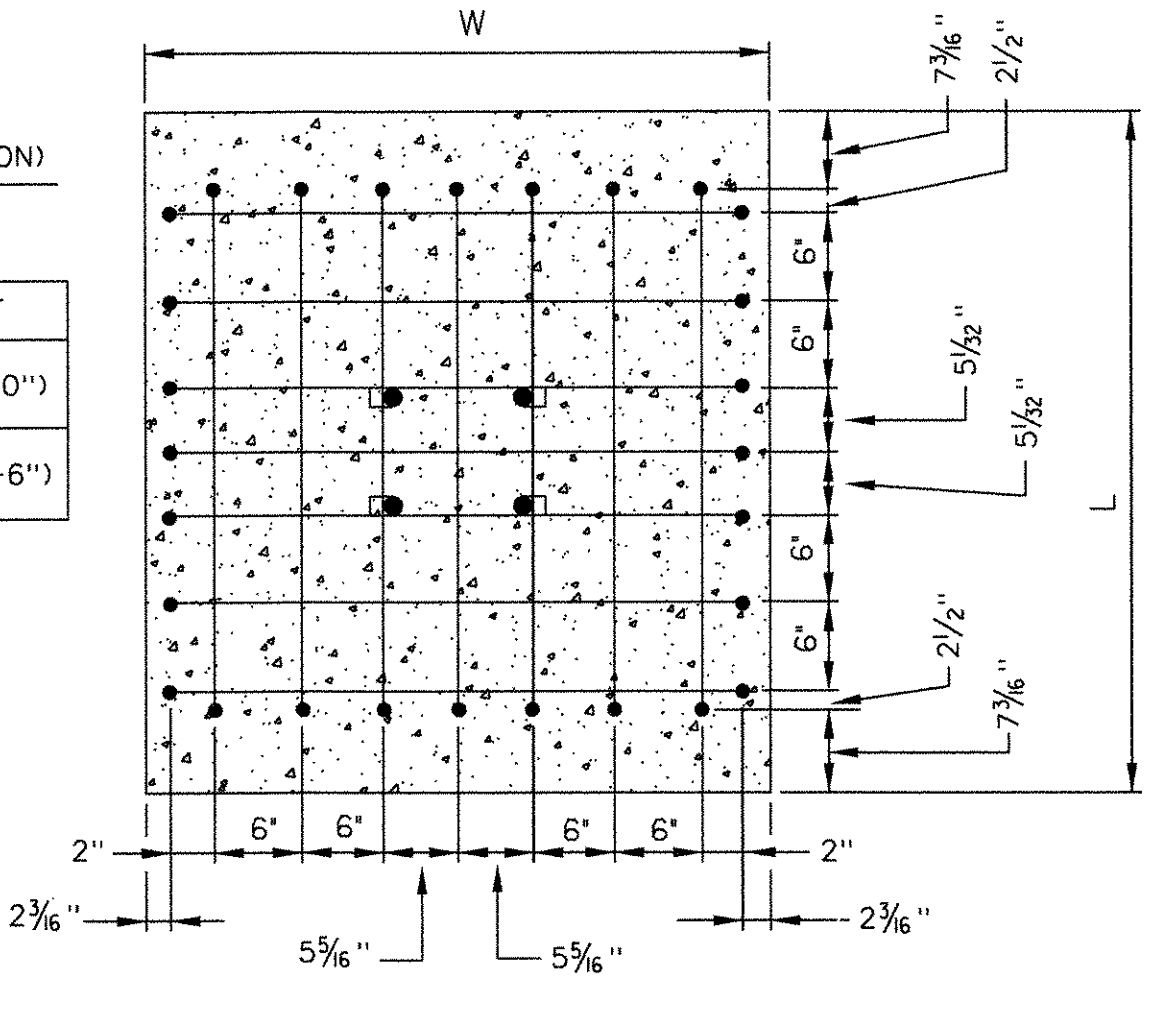

SECTION D-D
N.T.S.

CODE 009-00
STREET LIGHTING STANDARD
N.T.S.

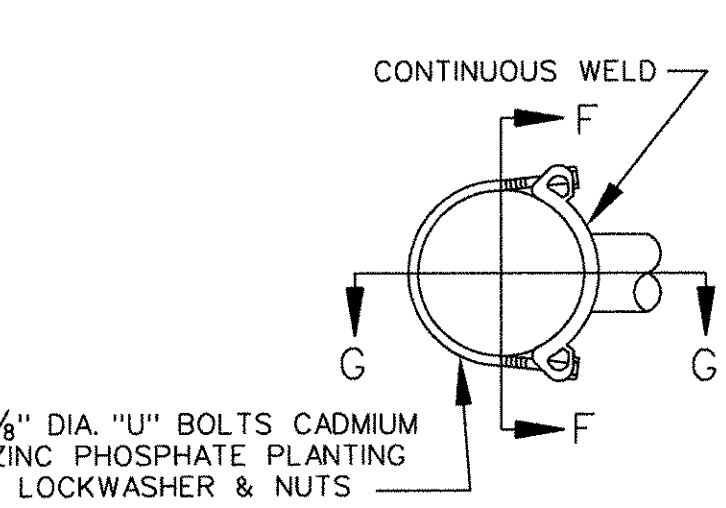

SECTION G-G
N.T.S.

TYPE	POLE DIAMETER
A	3.6' - 4.5'
B	6.1' - 6.9'
C	7.5' - 8.5'

CLAMP SIZE TABLE

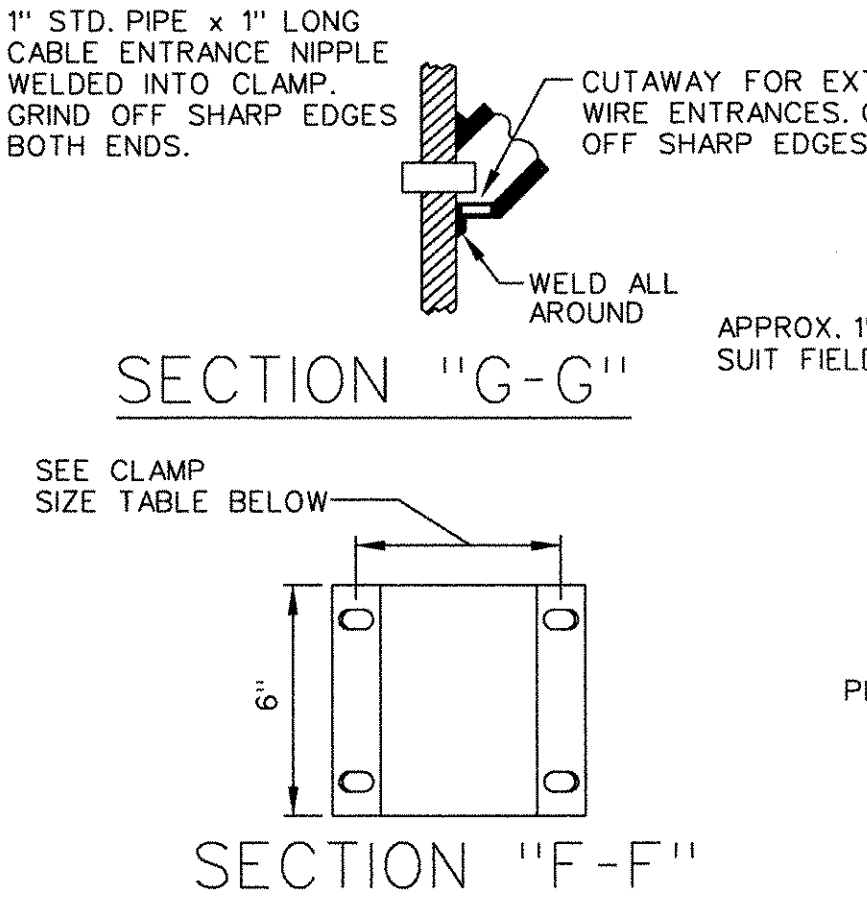

SECTION F-F
N.T.S.

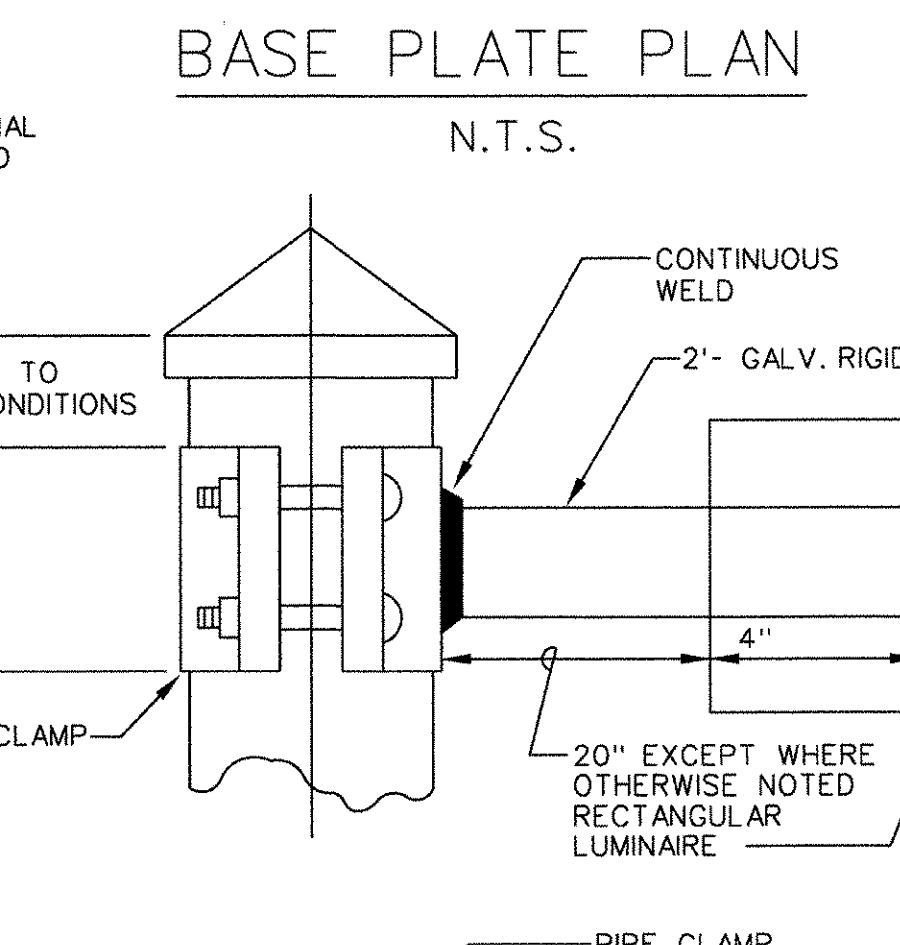

CLAMP-ON BRACKET & RECTANGULAR LUMINAIRE
N.T.S.

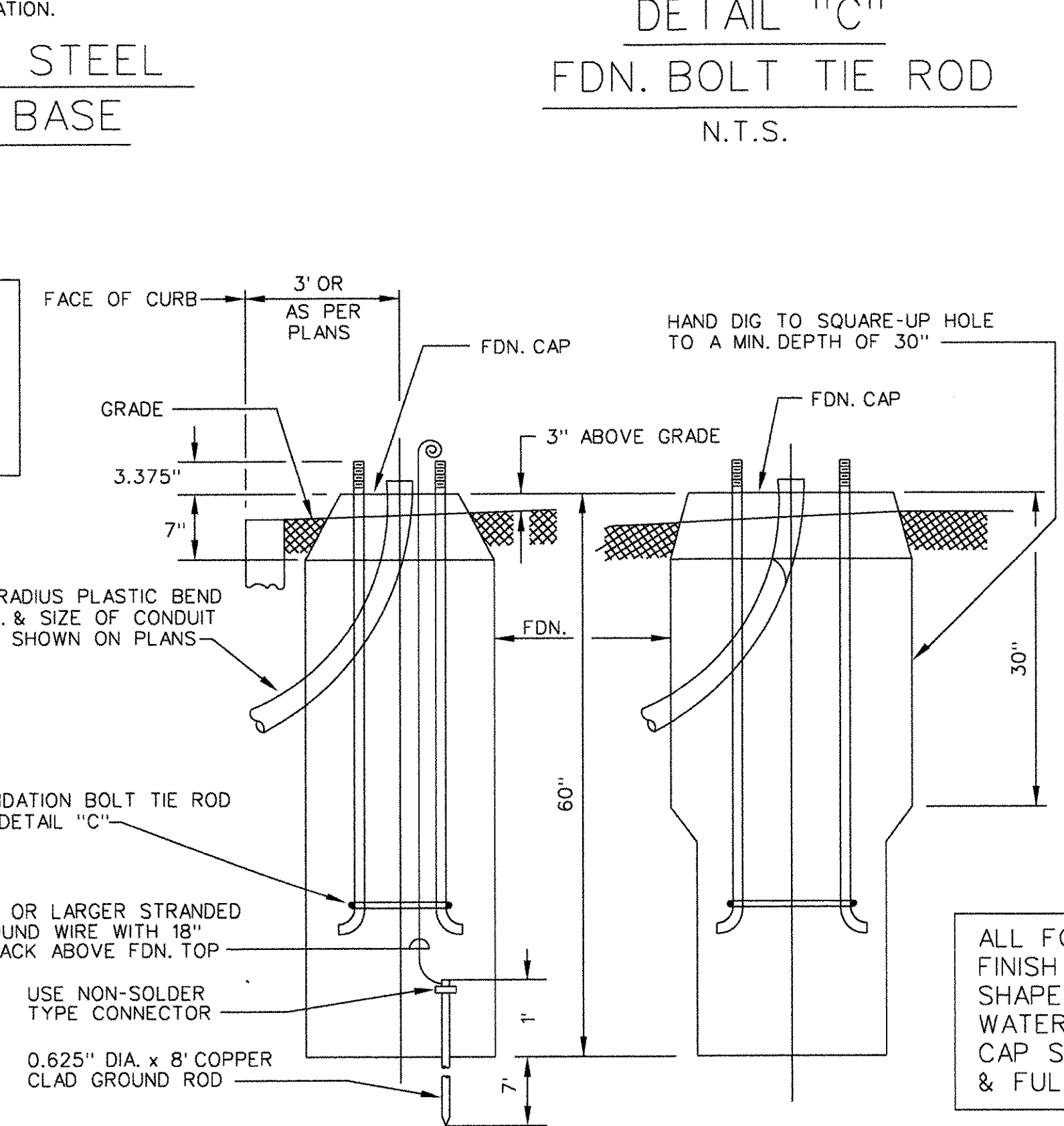

SECTION A-A
N.T.S.
SECTION B-B
N.T.S.
ANCHOR BASE STD. FOUNDATION

STD. CODE NO.	SHAFT LENGTH	SHAFT DEFLECTION x	MINIMUM LOAD x x	ANCHOR BOLT CIRCLE Ø	ANCHOR BOLT Ø & O.A.	HANDHOLE	LUMINAIRE MOUNTING HEIGHT	BRACKET FITTERS REQ'D	BRACKET LENGTH
009-00	28.5'	2.9"	880*	13.5"	1" x 40"	4' x 6.5"	38'	—	6'

* SHAFT DEFLECTION: SHAFT DEFLECTION MEASURED IN INCHES AT TOP, SHALL NOT BE GREATER THAN THAT SHOWN, FOR A HORIZONTAL LOAD OF 100 LBS. APPLIED 18 INCHES BELOW TOP OF SHAFT.

** SHAFT LOADING: SHAFTS SHALL WITHSTAND, AT THE GUARANTEED MINIMUM YIELD STRENGTH OF THE SHAFT MATERIAL, THE LOADS SHOWN IN THIS TABLE. THE LOAD SHALL BE APPLIED IN A SINGLE HORIZONTAL DIRECTION ANYWHERE AROUND THE CIRCUMFERENCE OF SHAFT 18 INCHES FROM THE TOP.

THERE SHALL BE NO EXTRA PAYMENT FOR SPECIAL FDN. (TO BE PAID FOR AS A NORMAL ST. LTG. STD. FDN. INSTALLATION)

ALL FOUNDATION CAPS SHALL HAVE A SMOOTH FINISH WITH BEVELED EDGES & SHALL BE SHAPED TO ALLOW COMPLETE DRAINAGE OF WATER. ANCHOR BOLT PROJECTIONS ABOVE CAP SHALL BE CLEANED OF ALL CONCRETE & FULLY USABLE THEIR FULL LENGTH.

SCALE: AS SHOWN

Date	Description	Chkd. by

DETAILS
EAST GRAND BOULEVARD BRIDGE
ANCHOR BASE STD. LTG. STD. (CODE 009-00)



Checked by: _____ Approved by: _____

PUBLIC LIGHTING DEPARTMENT
CITY OF DETROIT

Checked by: _____ Approved by: _____ File No. 51-0686

Designed by: C.E.A. Checked by: _____ Sheet No. 50 of 60

Disk File Name: 115PLDM Job File No. CEA 138200

Date: 3-03-08 Dwg. No. DTL-2-

USE	VOLT RATING NO.	ITEM NO.	CONDUCTOR	SYNTHETIC RUBBER	IMPREG-NATED PAPER	POLYETHYLENE	POLYVINYL-CHLORIDE	SHIELD OVER INSULATED CONDUCTOR	TAPE OVER INSULATED CONDUCTORS	IMPREG-NATED PAPER BELT	JACKET	LEAD SHEATH	COVERING OVER LEAD	STEEL TAPE ARMOR	COVERING OVER STEEL TAPE	COVERING OVER CONDUCTOR	
OVERHEAD LINE WIRE	—	1	#2-#6 AWG. HD. UNCOATED SOLID COPPER A.S.T.M. B1													.047" BLACK NEOPRENE	
	—	2	#4/0-#2/0 AWG. HD. UNCOATED 7/STR. COPPER A.S.T.M. B1													.063" BLACK NEOPRENE	
	—	3	#2 AWG. HD. UNCOATED SOLID COPPER A.S.T.M. B1													.062" BLACK POLYETHYLENE	
	—	4	#2 AWG. HD. UNCOATED SOLID COPPER A.S.T.M. B1													.047" BLACK POLYETHYLENE	
	—	5	#4/0-#2/0 AWG. HD. UNCOATED 7/STR. COPPER A.S.T.M. B8													.063" BLACK POLYETHYLENE	
SPECIAL EVENT FEEDER.	2000V.	6															
MULTI-ST. L.T.C.	2000V.	7															
TRAFFIC SIGNAL SECOND-ARY	2000V.	8															
RECEPTACLE BRACKET & LAMP POST WIRE	600V.	9	#8 AWG. 1/C UNCOATED SOFT COPPER A.S.T.M. B8				.062" C BLACK, (167 F) OR WHITE AS REDUCED CONSTRUCTION NOT PRINTED										
2/C AERIAL SERVICE	600V.	10	2/C#8 AWG. UNCOATED SOFT 7/STR. COPPER A.S.T.M. B8				.062" 75°C BLACK, (167 F) 8 CONSTRUCTION										
DISTRIBUTION CABLES	5000V. BELTED	11	3/C 350 MCM UNCOATED SOFT COPPER AEIC	.665" CONDUCTOR OIL VISCOSITY 1,000 SUS AT 100°C (212°F)						.45" OVERALL OIL VISCOSITY 1,000 SUS AT 100°C (212°F)		.095" COPPER BEARING LEAD	.090" HEAT & LIGHT STABILIZED BLACK HIGH MOLE- CULAR WEIGHT POLYETHYLENE OVER LEAD SHEATH				
	5000V. BELTED	12	3/C#2 AWG. UNCOATED SOFT COPPER AEIC	.085" CONDUCTOR OIL VISCOSITY 1,000 SUS AT 100°C (212°F)					.45" OVERALL OIL VISCOSITY 1,000 SUS AT 100°C (212°F)		.085" COPPER BEARING LEAD	.085" HEAT & LIGHT STABILIZED BLACK HIGH MOLE- CULAR WEIGHT POLYETHYLENE OVER LEAD SHEATH					
	5000V. BELTED	13	3/C#2 AWG. UNCOATED SOFT COPPER AEIC	.085" CONDUCTOR OIL VISCOSITY 1,000 SUS AT 100°C (212°F)					.45" OVERALL OIL VISCOSITY 1,000 SUS AT 100°C (212°F)		.085" COPPER BEARING LEAD	.085" HEAT & LIGHT STABILIZED BLACK HIGH MOLE- CULAR WEIGHT POLYETHYLENE OVER LEAD SHEATH					
	7000V. BELTED	14	3/C 350 MCM UNCOATED SOFT COPPER AEIC	.10" CONDUCTOR OIL VISCOSITY 1,000 SUS AT 100°C (212°F)					.45" OVERALL OIL VISCOSITY 1,000 SUS AT 100°C (212°F)		.095" COPPER BEARING LEAD	.090" HEAT & LIGHT STABILIZED BLACK HIGH MOLE- CULAR WEIGHT POLYETHYLENE OVER LEAD SHEATH					
	7000V. BELTED	15	3/C#2 AWG. UNCOATED SOFT COPPER AEIC	.10" CONDUCTOR OIL VISCOSITY 1,000 SUS AT 100°C (212°F)					.45" OVERALL OIL VISCOSITY 1,000 SUS AT 100°C (212°F)		.085" COPPER BEARING LEAD	.085" HEAT & LIGHT STABILIZED BLACK HIGH MOLE- CULAR WEIGHT POLYETHYLENE OVER LEAD SHEATH					
	7000V. BELTED	16	3/C 350 MCM UNCOATED SOFT COPPER AEIC	.10" CONDUCTOR OIL VISCOSITY 1,000 SUS AT 100°C (212°F)					.45" OVERALL OIL VISCOSITY 1,000 SUS AT 100°C (212°F)		.085" COPPER BEARING LEAD	.085" HEAT & LIGHT STABILIZED BLACK HIGH MOLE- CULAR WEIGHT POLYETHYLENE OVER LEAD SHEATH					
	7500V.	17	1/C#8 AWG. UNCOATED COPPER ASTM B3				.047" 60°C BLACK				.063" COMMERCIAL PURE						
	7500V.	18	1/C#8 AWG. UNCOATED COPPER ASTM B3				.047" 60°C BLACK				.063" COMMERCIAL PURE						
	24000V. SHIELDED	19	3/C 350 MCM UNCOATED SOFT COPPER AEIC	.230" CONDUCTOR OIL VISCOSITY 1,000 SUS AT 100°C (212°F)												.047" ASPHALTUM SATURATED JUTE OVER LEAD	
	24000V. SHIELDED	20	3/C 350 MCM UNCOATED SOFT COPPER AEIC	.230" CONDUCTOR OIL VISCOSITY 1,000 SUS AT 100°C (212°F)												.11" HEAT STABILIZED BLACK HIGH MOLE- CULAR WEIGHT POLYETHYLENE OVER LEAD SHEATH	
24000V. SHIELDED	21	3/C #2/0 AWG. UNCOATED SOFT COPPER AEIC	.245" CONDUCTOR OIL VISCOSITY 1,000 SUS AT 100°C (212°F)												.11" HEAT STABILIZED BLACK HIGH MOLE- CULAR WEIGHT POLYETHYLENE OVER LEAD SHEATH		
MULTI-CONDUCTOR SIGNAL CABLE, IN DUCT	—	22	#14 AWG. UNCOATED COPPER, NO. OF CONDUCTOR AS REQ'D. ASTM B3														
MULTI-CONDUCTOR SIGNAL CABLE, AERIAL (L.M.)	—	23	#14 AWG. UNCOATED COPPER, NO. OF CONDUCTOR AS REQ'D. ASTM B3														
8/C SERIES ST. L.T.C. IN DUCT	7500V.	24	8/C#8 AWG. SOLID COPPER	SPECIAL INSTRUCTION #63 OF 30X HEAVY RUBBER AND ONE LAYER OF LAPPED FILLED COTTON TAPE OVER EACH CONDUCTOR CENTRAL CONDUCTOR HAS ADDITIONAL .17" VARNISHED CAMBRIC TAPE REMAINING 7 CONDUCTORS EACH HAVE ADDITIONAL .094" VARNISHED CAMBRIC TAPE ONE OF 7 OUTSIDE CONDUCTORS WRAPPED WITH WHITE PAPER FOR IDENTIFICATION ALL CONDUCTORS CABLED WITH PARAFFINED JUTE (OUTSIDE FILLER). #94- BELT OF OIL SATURATED PAPER OVERALL .015 INCH COPPER BEARING LEAD BENEATH OVERALL.													
OVERHEAD FLEXIBLE TRAINER WIRE (SHIELDED)	—	25	1/C#2 AWG. & LARGER, SOFT COPPER, NO. OF CONDUCTOR & TINNED COPPER AS REQ'D. ASTM B173	SEMI-CONDUCTING TAPE OVER CONDUCTOR & .0268 OZONE RESISTING BITUL												.063" GENERAL PURPOSE HEAVY DUTY BLACK NEOPRENE	

COLOR CODED AS FOLLOWS:
RED - A CIRCUIT
BLACK - B CIRCUIT
WHITE - NEUTRAL

ALL MULTIPLE STREET LIGHTING, TRAFFIC SIGNAL SECONDARY AND SPECIAL EVENT CABLES INSTALLED IN CONDUIT SHALL BE AS PER THE FOLLOWING: CONDUCTORS COATED, STRANDED COPPER CONDUCTOR PER ASTM B-8 AND B-189, INSULATION MEETS OR EXCEEDS ALL REQUIREMENTS OF LATEST EDITION OF ICEA S-68-516, NEMA WC 8 FOR ETHYLENE-PROPYLENE RUBBER INSULATION AND ASTM D2802-78 AND UL STANDARD 44; JACKET MEETS OR EXCEEDS ALL REQUIREMENTS OF LATEST EDITION OF ICEA S-68-516, NEMA WC8 FOR HEAVY DUTY CHLOROSULFONATED-POLYETHYLENE. LISTED BY UNDERWRITER'S LABORATORIES INC. AS TYPE RHH OR RHW.

NOTE: PRIOR TO PLACING ORDER FOR PURCHASE OF THIS CABLE A SAMPLE LENGTH OF CABLE MUST FIRST BE SUBMITTED TO P.L.D. FOR THEIR APPROVAL.

ACCORDING TO SPECIFICATIONS

CONTINUED ON 207

• • • BINDER TAPE OVER SHIELDED INSULATED CONDUCTOR AND FILLERS TO BE COPPER OR BRONZE TAPE INTERCALATED WITH PAPER TAPE OR METALIZED PAPER TAPES

SCALE: AS SHOWN

REVISIONS		
Date	Description	Chkd. by

Checked by _____ Approved by _____

DEPARTMENT OF PUBLIC WORKS

CITY OF DETROIT

PUBLIC LIGHTING DEPARTMENT

Checked by _____ Approved by _____ File No. 51-0686

Designed by **C. E. A.** Checked by _____ Sheet No. 51 of 60

Disk File Name: 205PLDM Job File No. CEA 138200
Date: 3-03-08 Dwg. No. DTL-2-

1. DISTRIBUTION AND TRANSMISSION CABLES

ALL TRANSMISSION CABLES, (24 KV., ITEMS 11-16 INCLUSIVE) ARE FOR CIRCUITS WITH GROUNDED NEUTRAL, AND SHALL CONFORM STRICTLY WITH THE LATEST REVISION OF THE A.E.I.C. SPECIFICATION FOR IMPREGNATED PAPER INSULATED, LEAD COVERED SOLID TYPE CABLE, 9TH EDITION, DATED APRIL, 1954, AND CONSTRUCTION OPTIONS AS NOTED IN SHEET 1.

ALL DISTRIBUTION CABLES, (7 & 5 KV, ITEMS 19 & 21 INCLUSIVE) ARE FOR CIRCUITS WITH UNDERGROUND NEUTRAL AND SHALL ALSO CONFORM WITH THE ABOVE SPECIFICATION, WITH CONSTRUCTION OPTIONS AS NOTED IN TABLE 1.

2. OVERHEAD LINE WIRE

OVERHEAD LINE WIRE SHALL BE IN ACCORDANCE WITH LATEST REVISION OF ASA C8.34 (NEOPRENE COVERING) OR THE LATEST REVISION OF ASA C8.35 (POLYETHYLENE COVERING).

3. 8/C, #8AWG, STREET LIGHTING CABLE, 7500 V.

THIS IS A SPECIAL CONSTRUCTION AND SHALL BE MADE STRICTLY IN ACCORDANCE WITH THE DESCRIPTION IN TABLE 1. APPLICABLE REFERENCE SPECIFICATIONS SHOWN BELOW:

4. OTHER RUBBER OR THERMOPLASTIC INSULATED CABLES, LEADED & NON-LEADED

WIRE SIZE, INSULATION TYPE AND NORMAL THICKNESSES, OTHER CONSTRUCTION FEATURES SHALL BE AS SHOWN IN TABLE 1, AND APPLICABLE REFERENCE SPECIFICATIONS SHOWN BELOW:

INSULATIONS

THE MINIMUM INSULATION THICKNESS OF ANY OF THESE CABLES SHALL BE LESS THAN 90% OF THE NOMINAL THICKNESS SHOWN ON TABLE 1.

THE PHYSICAL AND AGING PROPERTIES OF THERMOPLASTIC AND RUBBER INSULATIONS SHALL BE AS FOLLOWS:

CONDUCTORS

ALL CONDUCTORS SHALL BE COPPER, COMPLYING WITH THE LATEST REVISIONS OF ASTM SPECIFICATIONS, AS FOLLOWS:

SOFT OR ANNEALED, BARE COPPER WIRE	ASTM B3
MEDIUM HARD DRAWN COPPER WIRE	ASTM B2
HARD DRAWN COPPER WIRE	ASTM B1
CONCENTRIC-LAY-STRANDED COPPER CONDUCTORS, HARD, MEDIUM HARD OR SOFT, COATED OR UNCOATED, AS REQUIRED.	ASTM B8
ROPE-LAY-STRANDED, SOFT, COPPER CONDUCTORS, COATED OR UNCOATED, AS REQUIRED.	ASTM B173
SOFT, SOLID COPPER CONDUCTORS, TINNED	ASTM B33
SOFT, SOLID COPPER CONDUCTORS, LEAD OR LEAD ALLOY COATED	ASTM B189

		POLYVINYL-CHLORIDE 60°C (140°F)	POLYVINYL-CHLORIDE 75°C (167°F)	HIGH MOLECULAR WEIGHT NATURAL POLYETHYLENE	SYNTHETIC RUBBER 75°C (167°F) HEAT & MOISTURE RESISTANT	OZONE RESISTING BUTYL RUBBER
ORIGINAL	TENSILE STRENGTH PSI	2300, MIN.	2300, MIN.	1400, MIN.	700, MIN.	600, MIN.
	ELONGATION AT RUPTURE, PERCENT	250, MIN.	250, MIN.	250, MIN.	300, MIN. & 13mm(.5") SET, MAX.	350, MIN. & 13mm(.5") SET, MAX.
AIR OVEN TEST, TIME & TEMP, AS NOTED	TENSILE STRENGTH % OF ORIGINAL	65, MIN. 168 HRS., 100 ± 1°C (212 ± 1.8°F)	120, MAX. 80, MIN. 168 HRS., 120 ± 1°C (248 ± 1.8°F)	75, MIN. 48 HRS., 100 ± 1°C (212 ± 1.8°F)	—	60, MIN. 168 HRS., 100 ± 1°C (212 ± 1.8°F)
	ELONGATION % OF ORIGINAL	65, MIN. 168 HRS., 100 ± 1°C (212 ± 1.8°F)	75, MIN. 168 HRS., 120 ± 1°C (248 ± 1.8°F)	75, MIN. 48 HRS., 100 ± 1°C (212 ± 1.8°F)	—	60, MIN. 168 HRS., 100 ± 1°C (212 ± 1.8°F)
OXYGEN PRESSURE TEST	TENSILE STRENGTH % OF ORIGINAL	—	—	—	50, MIN. 168 HRS., 80 ± 1°C (176 ± 1.8°F)	—
	ELONGATION % OF ORIGINAL	—	—	—	50, MIN. 168 HRS., 80 ± 1°C (176 ± 1.8°F)	—
AIR PRESSURE HEAT TEST	TENSILE STRENGTH % OF ORIGINAL	—	—	—	20 HRS., 127 ± 1°C (260 ± 1.8°F)	50, MIN. 40 HRS., 127 ± 1°C (260 ± 1.8°F)
	ELONGATION % OF ORIGINAL	—	—	—	20 HRS., 127 ± 1°C (260 ± 1.8°F)	50, MIN. 40 HRS., 127 ± 1°C (260 ± 1.8°F)
HEAT DISTORTION 121 ± 1°C (250 ± 1.8°F)	% OF ORIGINAL	50, MAX.	25, MAX.	—	—	—
OIL IMMERSION 4 HRS., 70 ± 1°C (158 ± 1.8°F)	TENSILE STRENGTH % OF ORIGINAL	85, MIN.	85, MIN.	—	—	—
	ELONGATION % OF ORIGINAL	85, MIN.	85, MIN.	—	—	—
HEAT SHOCK 121 ± 1°C (250 ± 1.8°F)	—	NO CRACKS	NO CRACKS	—	—	—
COLD BEND	—	NO CRACKS -30 ± 1°C (-22 ± 1.8°F)	NO CRACKS -30 ± 1°C (-22 ± 1.8°F)	NO CRACKS -55 ± 1°C (-67 ± 1.8°F)	—	—
	—	—	—	—	—	—
INSULATION RESISTANCE CONSTANT AT 15.6°C (60 ± 1.8°F)	—	1,000 MIN.	2,000 MIN.	50,000 MIN.	4,000 MIN.	20,000 MIN.
FLAME RESISTANCE PROPERTIES	—	SECT. 6.5 IPCEA S-61-402	SECT. 6.5 IPCEA S-61-402	—	—	—
	—	—	—	—	—	—
ACCELERATED WATER ABSORPTION REQUIREMENT	ELECTRIC-AL METHOD	DIELECTRIC CONSTANT, 1 DAY	10, MAX.	10, MAX.	—	5, MAX.
		% CAPACITANCE INCREASE	1-14 DAYS-10, MAX. 7-14 DAYS-5, MAX.	1-14 DAYS-4.0, MAX. 7-14 DAYS-2.0, MAX.	—	1-14 DAYS-10.0, MAX. 7-14 DAYS-4.0, MAX.
	OR GRAVIMETRIC METHOD	TEMP.	50 ± 1°C (122 ± 1.8°F)	75 ± 1°C (167 ± 1.8°F)	—	75 ± 1°C (167 ± 1.8°F)
TEST IN ACCORDANCE WITH LATEST REVISION OF:	—	IPCEA S-61-402 (EXCEPTIONS ARE NOTED ABOVE)	IPCEA S-61-402	IPCEA S-61-402	IPCEA S-19-81 (EXCEPTIONS ARE NOTED ABOVE)	IPCEA S-19-81

FOR #6 AWG AND LARGER, USING BUFFED DIE-CUT SPECIMENS, THE FOLLOWING VALUES SHALL APPLY:

- ELONGATION AFTER AIR OVEN TEST 45% MIN.
- ELONGATION AFTER AIR OVEN TEST 50% MIN.
- OR •• TENSILE STRENGTH AFTER OIL IMMERSION 80% MIN.
- OR •• ELONGATION AFTER OIL IMMERSION 60% MIN.

JACKETS

THE MINIMUM JACKET THICKNESS SHALL NOT BE LESS THAN 80% OF THE NOMINAL THICKNESS SHOWN ON TABLE 1.

		NEOPRENE BLACK, HEAVY DUTY	NEOPRENE BLACK GENERAL PURPOSE	POLYVINYL-CHLORIDE, BLACK	HEAT & LIGHT STABILIZED BLACK POLYETHYLENE COVER'G OVER LEAD SHEATH
ORIGINAL	TENSILE STRENGTH PSI	1800, MIN.	1500, MIN.	1500, MIN.	1400, MIN.
	ELONGATION AT RUPTURE, %	300, MIN. & 10mm(.375") MAX. SET	250, MIN. & 10mm(.375") MAX. SET	100, MIN.	350, MIN.
AIR OVEN TEST, TIME & TEMP, AS NOTED	TENSILE STRENGTH % OF ORIGINAL	—	—	75 MIN. 120 HRS. 121 ± 1°C (250 ± 1.8°F)	75, MIN.
	ELONGATION % OF ORIGINAL	—	—	60 MIN. 120 HRS. 121 ± 1°C (250 ± 1.8°F)	75, MIN.
OXYGEN PRESSURE TEST 168 HRS., 80 ± 1°C (176 ± 1.8°F)	TENSILE STRENGTH % OF ORIGINAL	50, MIN.	50, MIN.	—	—
	ELONGATION % OF ORIGINAL	50, MIN.	50, MIN.	—	—
AIR PRESSURE HEAT TEST 20 HRS., 127 ± 1°C (260 ± 1.8°F)	TENSILE STRENGTH % OF ORIGINAL	50, MIN.	50, MIN.	—	—
	ELONGATION % OF ORIGINAL	50, MIN.	50, MIN.	—	—
OIL IMMERSION TEST, TIME & TEMP, AS NOTED	TENSILE STRENGTH % OF ORIGINAL	60 MIN. 18 HRS. 121 ± 1°C (250 ± 1.8°F)	60 MIN. 18 HRS. 121 ± 1°C (250 ± 1.8°F)	60 MIN. 4 HRS. 70 ± 1°C (158 ± 1.8°F)	—
	ELONGATION % OF ORIGINAL	60 MIN. 18 HRS. 121 ± 1°C (250 ± 1.8°F)	60 MIN. 18 HRS. 121 ± 1°C (250 ± 1.8°F)	60 MIN. 4 HRS. 70 ± 1°C (158 ± 1.8°F)	—
HEAT DISTORTION PERCENT OF UNAGED VALUE	—	—	—	50, MAX. 90 ± 1°C (194 ± 1.8°F)	25, MAX. 90 ± 1°C (194 ± 1.8°F)
HEAT SHOCK 121 ± 1°C (250 ± 1.8°F)	—	—	—	NO CRACKS	—
COLD BEND TEST -35 ± 1°C (-31 ± 1.8°F)	—	—	—	NO CRACKS	NO CRACKS
ENVIRONMENTAL CRACKING	—	—	—	—	NO CRACKS
LIGHT ABSORPTIVITY	—	—	—	—	24,000, MIN.
TEST IN ACCORDANCE WITH LATEST REVISION OF:	—	IPCEA S-19-82	IPCEA S-61-402	IPCEA INTERIM REVISION #1 PUB. S-54-401 SEPT. 1959	—

SCALE: AS SHOWN		
REVISIONS		
Date	Description	Chkd. by

DETAILS
EAST GRAND BOULEVARD BRIDGE

CABLE & WIRE SPECIFICATIONS

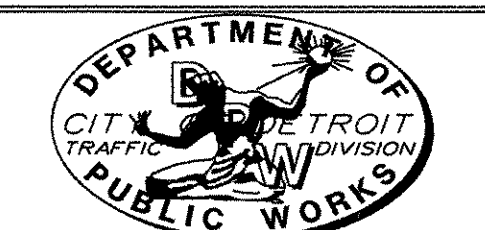

Checked by _____ Approved by _____

PUBLIC LIGHTING DEPARTMENT
CITY OF DETROIT

Checked by _____ Approved by _____ File No. 51-0686

Consulting Engineering Associates, Inc.
10800 WYOMING AVE. DETROIT MICHIGAN 48221
TELEPHONE: (313) 341-5797 FAX: 341-0205

Designed by C. E. A. Checked by _____ Sheet No. 52 of 60

Disk File Name 206PLDM Job File No. CEA 138200

Date 3-03-08 Dwg. No. DTL-2-

206

REVISION DATE: APRIL 1, 2001 Computer File: T:\138200 E. Grand Blvd Bridge\DETAILS\206pldm.dgn DATE PLOTTED: 3/20/2008 TIME: 2:46:23 PM

CERTIFIED TEST REPORTS

SHIPMENTS OF WIRE AND CABLE SHALL NOT BE CONSIDERED COMPLETE UNTIL CERTIFIED TEST REPORTS ARE RECEIVED AND APPROVED. TEST REPORTS FOR VARIOUS ITEMS OF WIRE AND CABLE SHOWN ON SHEET 1 SHALL CONTAIN THE FOLLOWING TEST RESULTS:

ITEMS 1 - 5 INCLUSIVE - OVERHEAD LINE WIRE

1. CONDUCTOR CONTINUITY, RESISTANCE, TENSILE STRENGTH AND ELONGATION TESTS.
2. COVERING THICKNESS, PHYSICAL AND AGING TESTS.
3. WEIGHT OF FINISHED WIRE.

ALL TESTS IN ACCORDANCE WITH THE LATEST REVISION OF ASA 8.34 (NEOPRENE COVERING) OR ASA 8.35 (POLYETHYLENE COVERING).

ITEMS 6 - 10 INCLUSIVE

1. CONDUCTOR CONTINUITY, RESISTANCE, TENSILE STRENGTH, AND ELONGATION TESTS IN ACCORDANCE WITH THE LATEST REVISIONS OF ASTM B8, B33 OR B189.
2. THE PHYSICAL AND OTHER TESTS FOR THE SPECIFIED INSULATION SHOWN ON SHEET 2.
3. INSULATION THICKNESS MEASUREMENTS.
4. THE ALTERNATING-CURRENT VOLTAGE TEST IN ACCORDANCE WITH THE LATEST REVISION OF IPCEA S-61-402.
5. INSULATION RESISTANCE TEST, INSULATION RESISTANCE CONSTANT AS SHOWN ON SHEET 2.
6. (CABLE ITEM 8 ONLY) MINIMUM, MAXIMUM AND AVERAGE LEAD THICKNESS MEASUREMENTS SHALL ALSO BE INCLUDED.
7. (CABLE ITEM 10 ONLY) A RIP TEST SHALL ALSO BE INCLUDED AS FOLLOWS:

A INCH (6") SAMPLE OF THE COMPLETED 2 CONDUCTOR WIRE WITH CLEANLY CUT ENDS SHALL BE SUBJECTED TO A TEMPERATURE OF -10°F FOR ONE HOUR, WHILE STILL COLD. THE TWO INSULATED CONDUCTORS SHALL BE SEPARATED AT ONE END FOR A DISTANCE OF APPROXIMATELY 3 INCHES AND THEN SHALL BE TORN APART WITH STEADY PULL AT A RATE OF 33 INCHES IN ONE SECOND OR LESS. THERE SHALL BE NO DAMAGE TO THE INSULATION.

ITEMS 11 - 16 INCLUSIVE - DISTRIBUTION CABLES UNDER 10KV. RATING

1. CONDUCTOR RESISTANCE.
2. SHEATH THICKNESS MEASUREMENTS.
3. HIGH VOLTAGE TEST.
4. MECHANICAL INTEGRITY TEST.
5. BENDING TEST.
6. SPARK TEST ON COVERING OVER LEAD SHEATH ON EACH LENGTH IF COVERING IS SPECIFIED.

ALL TESTS SHALL BE IN ACCORDANCE WITH THE LATEST REVISION OF "SOLID TYPE IMPREGNATED-PAPER-INSULATED LEAD-COVERED CABLE SPECIFICATION" PUBLISHED BY THE ASSOCIATION OF EDISON ILLUMINATING COMPANIES.

ITEMS 17 - 18 INCLUSIVE - SERIES STREET LIGHTING CABLE

1. CONDUCTOR RESISTANCE AND CONTINUITY, IN ACCORDANCE WITH THE LATEST REVISION OF ASTM B-3.
2. THE PHYSICAL AND OTHER TESTS FOR HIGH MOLECULAR WEIGHT POLYETHYLENE INSULATION AS SHOWN ON SHEET 2.
3. THE PHYSICAL AND OTHER TESTS FOR 60°C (140°F) POLYVINYL-CHLORIDE INSULATION AS SHOWN ON SHEET 2.
4. THE FOLLOWING TESTS SHALL ALSO BE MADE AND REPORTED:

HIGH VOLTAGE TEST-AFTER NOT LESS THAN SIX HOURS IMMERSION IN WATER AT (15.6°C. (60°F) AND WHILE STILL IMMERSER, EACH REEL OF INSULATION CABLE WITHOUT LEAD, SHALL WITHSTAND A 60 CYCLE POTENTIAL OF 30,000 VOLTS FOR A PERIOD OF FIVE (5) MINUTES.

INSULATION RESISTANCE TEST-THE INSULATION RESISTANCE SHALL NOT BE LESS THAN 26,500 MEGOHMS PER THOUSAND FEET AT (15.6°C. 60°F) THIS TEST SHALL BE CONDUCTED UPON COMPLETION OF THE HIGH VOLTAGE TEST.

SHORT-TIME DIELECTRIC STRENGTH TEST - A TEN(10)FT. SAMPLE OF THE FINISHED CABLE WITH ONLY THE LEAD REMOVED, AFTER TWELVE (2) HOURS SUBMERSION IN WATER AND WHILE STILL IMMERSER, SHALL WITHSTAND A VOLTAGE TEST OF 60,000 VOLTS 60 CYCLE A.C. FOR FIVE (5) MINUTES. ON COMPLETION OF THIS TEST, THE VOLTAGE WILL BE GRADUALLY RAISED IN ACCORDANCE WITH I.P.C.E.A. SPECIFICATIONS, UNTIL THE INSULATION IS PUNCTURED. THIS VOLTAGE SHALL BE RECORDED AND SHALL BE NOT LESS THAN 72,000 VOLTS.

EXTERNAL CORONA TEST-THIS TEST SHALL BE CONDUCTED ON ONE(1)SAMPLE PER 10,000 FT. OF COMPLETED CABLE EIGHTEEN(18)INCHES LONG WITH ONLY THE LEAD SHEATH REMOVED, AFTER WHICH SHALL BE WIPED WITH A CLEAN DRY CLOTH. THESE SAMPLES SHALL BE BENT AND MAINTAINED IN A "U-SHAPE" HAVING A BENDING DIAMETER EQUAL TO FIVE TIMES THE INSULATED CABLE DIAMETER. THE BENT SAMPLES SHALL THEN BE PLACED IN A VERTICAL POSITION ON A FLAT METALLIC GROUNDED PLATE AND 60 CYCLE A.C. VOLTAGE SHALL BE GRADUALLY APPLIED WITH A CORONA-LEVEL TEST APPARATUS OF THE FILTER-CIRCUIT TYPE, MAINTAINING SUFFICIENT AMPLIFICATION TO INDICATE THE EXISTENCE OF CORONA DISCHARGE. THIS VOLTAGE SHALL BE RAISED UNTIL CORONA IS INDICATED, AND SHALL NOT BE LESS THAN 8,200 VOLTS RMS.

THE VOLTAGE SHALL THEN BE RAISED TO 25,000 VOLTS AND MAINTAINED FOR SIX(6) HOURS WITHOUT FAILURE OF THE INSULATION. THE VOLTAGE SHALL NOT BE RAISED IN 10% STEPS AT TEN(10) MINUTE INTERVALS UNTIL FAILURE OF THE INSULATION OR FLASHOVER OCCURS.

THESE VOLTAGES SHALL BE RECORDED AND REPORTED.

INTERNAL-CORONA-LEVEL-EACH LENGTH OF COMPLETED CABLE SHALL BE TESTED IN ACCORDANCE WITH SECTION 6.13 OF THE LATEST REVISION OF I.P.C.E.A. STANDARD S-61-402, EXCEPT THAT THE MINIMUM CORONA LEVEL SHALL BE 8,200 VOLTS.

ITEMS 19 - 21 INCLUSIVE - TRANSMISSION CABLES.

1. CONDUCTOR RESISTANCE
2. SHEATH THICKNESS MEASUREMENT
3. HIGH VOLTAGE TEST
4. MECHANICAL INTEGRITY TEST
5. BENDING TEST
6. IONIZATION TEST
7. HIGH VOLTAGE-TIME TEST) ONE TEST PER ORDER OR
8. DIELECTRIC POWER TEST) THERE IS A QUANTITY LIMITATION OF
9. POWER FACTOR TEST) 25' ON THESE TESTS PER AEC
10. SPARK TEST ON COVERING OVERHEAD SHEATH ON EACH LENGTH

ALL TESTS SHALL BE IN ACCORDANCE WITH THE LATEST REVISION OF "SOLID-TYPE IMPREGNATED-PAPER-INSULATED LEAD-COVERED CABLE SPECIFICATION," PUBLISHED BY THE ASSOCIATION OF EDISON ILLUMINATING COMPANIES.

ITEMS 22 -23 INCLUSIVE - MULTI-CONDUCTOR TRAFFIC SIGNAL CABLE

1. INDIVIDUAL CONDUCTOR RESISTANCE IN ACCORDANCE WITH THE LATEST REVISION OF ASTM B3.
2. INSULATION THICKNESS MEASUREMENTS.
3. INSULATION PHYSICAL AND OTHER TESTS FOR 60°C (140°F) POLYVINYL CHLORIDE IS SHOWN ON SHEET 2.
4. ALTERNATING CURRENT VOLTAGE TEST.
5. INSULATION RESISTANCE TEST INSULATION RESISTANCE CONSTANT AS SHOWN ON SHEET 2.
6. (CABLE ITEM 23 ONLY)
 - a. POLYVINYL CHLORIDE JACKET PHYSICAL AND OTHER TESTS SHOWN ON SHEET 2.
 - b. JACKET THICKNESS MEASUREMENTS.
7. (CABLE ITEM 22 ONLY), LEAD SHEATH THICKNESS MEASUREMENTS.

TESTS NO. 4-7, INCLUSIVE, SHALL BE MADE IN ACCORDANCE WITH THE LATEST REVISION OF I.P.C.E.A. S-61-402, EXCEPT THAT THE INSULATION RESISTANCE CONSTANT SHALL BE 1000 AT 15.6°C (60°F).

ITEM 24 - B/C SERIES STREET LIGHTING CABLE

1. CONDUCTOR CONTINUITY AND RESISTANCE IN ACCORDANCE WITH THE LATEST REVISION OF ASTM B-33.
2. LEAD SHEATH THICKNESS MEASUREMENTS.
3. A HIGH VOLTAGE TEST CONSISTING OF 22,500 VOLTS, 60 CYCLES A.C. FOR A DURATION OF 5 MINUTES, BETWEEN CONDUCTORS AND FROM EACH CONDUCTOR TO THE LEAD SHEATH.

ITEM 25 - FLEXIBLE OVERHEAD TRAINER WIRE

1. CONDUCTOR RESISTANCE, TENSILE STRENGTH AND ELONGATION IN ACCORDANCE WITH THE LATEST REVISION OF ASTM B-173.
2. INSULATION PHYSICAL AND OTHER TESTS SHOWN ON SHEET-2.
3. ADDITIONAL INSULATION TESTS IN ACCORDANCE WITH THE LATEST REVISION OF I.P.C.E.A. S-19-81 AS FOLLOWS:
 - a. ALTERNATING-CURRENT VOLTAGE TEST.
 - b. INSULATION RESISTANCE TEST.
 - c. DIRECT-CURRENT VOLTAGE TEST.
 - d. CORONA LEVEL TEST.
 - e. SHORT-TIME DIELECTRIC STRENGTH TEST.
 - f. COLD-BENDING AND LONG-TIME DIELECTRIC STRENGTH TEST.
 - g. CAPACITY AND POWER FACTOR TEST.
 - h. OZONE RESISTANCE TEST.
4. PHYSICAL AND OTHER TESTS ON THE NEOPRENE JACKET (GENERAL PURPOSE OR HEAVY DUTY), AS SHOWN ON SHEET 2.
5. JACKET THICKNESS MEASUREMENTS

ITEM 26 - SUPERVISORY CONTROL CABLE (MULTI-CONDUCTOR)

1. CONDUCTOR RESISTANCE, TENSILE STRENGTH AND ELONGATION, IN ACCORDANCE WITH THE LATEST REVISION OF ASTM B-3.
2. INSULATION PHYSICAL FOR 60°C (140°F) PVC INSULATION AND OTHER TESTS SHOWN ON SHEET 2.
3. INSULATION RESISTANCE TESTS.
4. VOLTAGE TESTS PER IPCEA S-61-402.
5. INSULATION THICKNESS.
6. LEAD SHEATH THICKNESS.
7. THICKNESS OF COVERING OVER LEAD SHEATH.
8. SPARK TEST ON COVER LEAD SHEATH ON EACH LENGTH.

ITEM 27 - INTEGRAL MESSENGER COMMUNICATIONS CABLE (MULTI-PAIR)

ITEM 28 - COMMUNICATIONS CABLE

ITEM 29 - COMMUNICATIONS CABLE, LEAD SHEATH

ITEM 30 - COMMUNICATIONS CABLE, LEAD SHEATH, DIRECT BURIAL

MULTI-PAIR COMMUNICATION CABLES (Maximum Mutual Capacities = 90 nf per mile) (ALSO FOR TRAFFIC SIGNAL CHRONOPLAN) AND SUPERVISORY

ITEM NO.	USE AND RATING	CONDUCTOR	INSULATION (b)	TAPE OVER INSULATION CONDUCTORS	INNER BELT	SHIELD OVER TAPE OR BELT	JACKET OR SHEATH	COVERING OVER SHEATH
27	(a) AERIAL 600V.		.025" (c) CLASS B POLYETHYLENE (ASTM D 1351)			CORRUGATED, LONGITUDINAL, ANNEALED, (c) .004" COPPER	BLACK POLYETHYLENE (ASTM D 2308), THICKNESSES OVER CORE AND MESSENGER AND WEB DIMENSIONS IN ACCORDANCE WITH REA SPECIFICATION PE-38.	
28	IN DUCT 600V.	*6 0R *19 AWG, SOLID, UNCOATED COPPER (ASTM B3)-NUMBER OF PAIRS AS REQUIRED		12.5 PERCENT MINIMUM LAP, POLYETHYLENE TEREPHTHALATE	BLACK POLYETHYLENE (ASTM D 2308) .010" MIN. .030" MAX. THICKNESS		BLACK POLYETHYLENE (ASTM D 2308), THICKNESS IN ACCORDANCE WITH PARAGRAPH 3.6, 7.3, 7 AND TABLE IV OF FED. SPEC. J.C.111.	
29	IN DUCT 600V.		.031" (e) DIOCTYL PHTHALATE PLASTICIZED PVC (ASTM D 2219)				LEAD-ANTIMONY THICKNESS PER ITEM 26 EXCEPT .063" MIN. THICKNESS (c)	
30	DIRECT BURIAL 600V.	*6 0R *19 AWG, SOLID, TINNED COPPER (ASTM B 33)-NUMBER OF PAIRS AS REQUIRED					COMMERCIAL PURE LEAD, THICKNESS PER ITEMS 22 & 23.	ASPHALTUM-SATURATED JUTE STEEL ARMOR PER ITEMS 17 & 18.

TEST REPORTS

SHIPMENTS OF WIRE AND CABLE SHALL NOT BE CONSIDERED COMPLETE UNTIL CERTIFIED TEST REPORTS ARE RECEIVED AND APPROVED. TEST REPORTS FOR THE VARIOUS ITEMS ABOVE SHALL SHOW COMPLIANCE WITH CITED SPECIFICATIONS, LISTING TEST RESULTS, AS WELL AS THE FOLLOWING TESTS:

1. CONDUCTOR RESISTANCE OF EACH LENGTH OF EACH CONDUCTOR IN OHMS PER 1000'
2. CERTIFICATION OF MUTUAL CAPACITANCE OF ALL CABLES AND OF NON-INJURIOUS EFFECT OF FLOODING COMPOUND ON ITEM 27.

- (a) "FIGURE 8" CONSTRUCTION, MESSENGER SHALL BE 7 STRAND EHS GALVANIZED, CLASS A, .25" NORMAL DIAM. (ASTM A 475) AND SHALL BE FULL FLOODED.
- (b) COLOR CODED PER FEDERAL SPECIFICATION J-C-111.
- (c) NOMINAL THICKNESS, mm (INCHES).

TRAFFIC SIGNAL SECONDARY OR MULTIPLE STREET LIGHTING CABLE DETAIL OF SEALING OF CABLE END

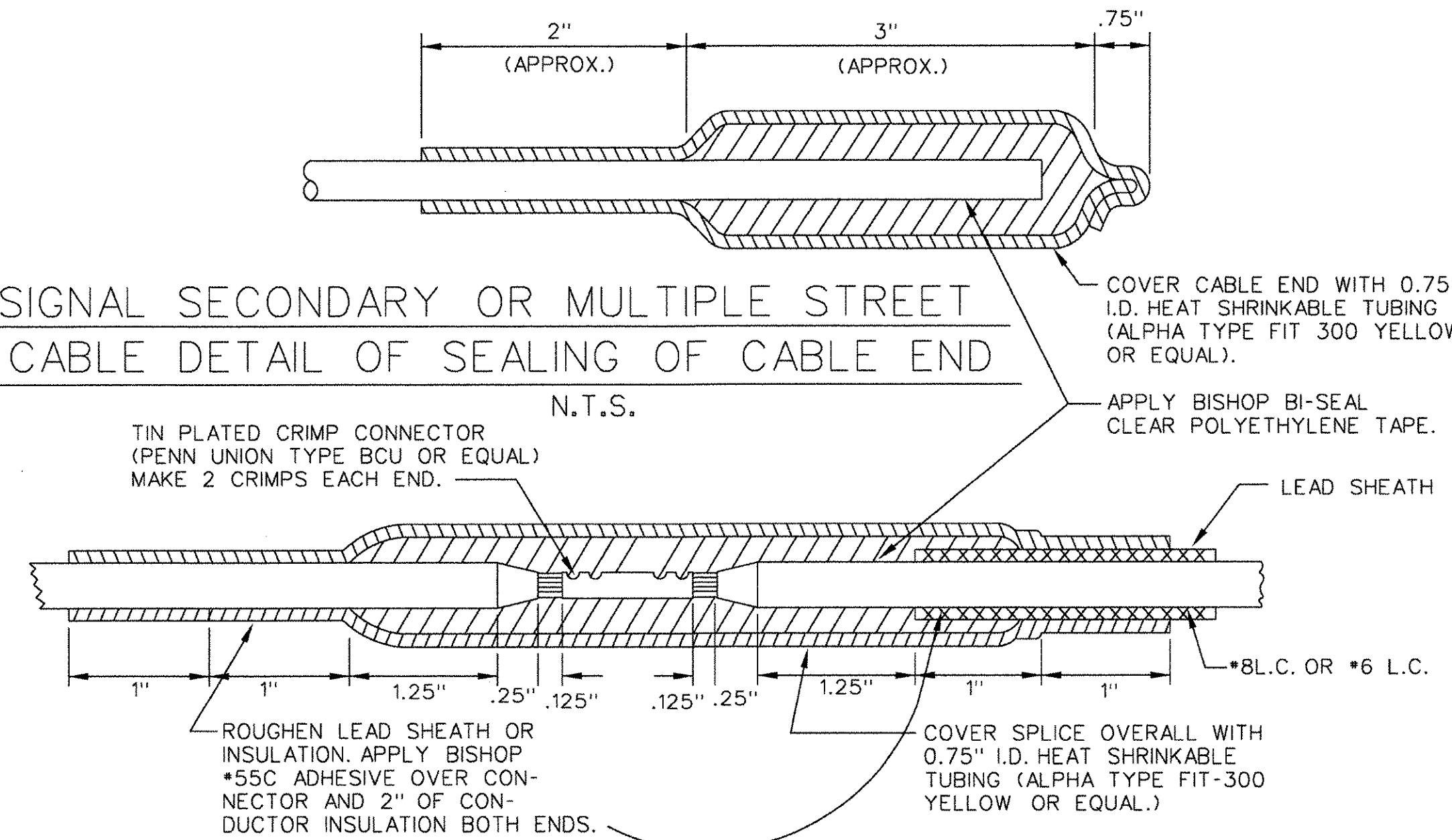

TRAFFIC SIGNAL SECONDARY OR MULTIPLE STREET LIGHTING SPLICE DETAIL "A"
P.J. CABLE TO *8 OR *6 L.C. CABLE OR P.J. CABLE TO P.J. CABLE
N.T.S.

SCALE: AS SHOWN

REVISIONS		
Date	Description	Chkd. by

DETAILS
EAST GRAND BOULEVARD BRIDGE
CABLE & WIRE SPECIFICATIONS

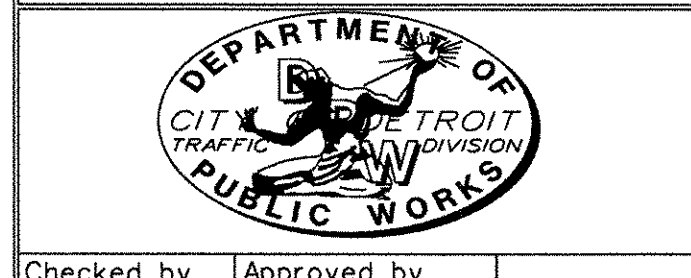

Checked by _____ Approved by _____
PUBLIC LIGHTING DEPARTMENT
CITY OF DETROIT
Checked by _____ Approved by _____ File No. 51-0686

Consulting Engineering Associates, Inc.
18580 WYOMING AVE. DETROIT MICHIGAN 48221
TELEPHONE: (313) 341-5797 FAX: 341-0205
Designed by C.E.A. Checked by _____ Sheet No. 53 of 60
Disk File Name Job File No. 207PLDM CEA 138200
Date 3-03-08 Dwg. No. DTL-2-

REVISION DATE: APRIL 1, 2001
Computer File: T:\138200 E. Grand Blvd Bridge\DETAILS\207plde.dgn
DATE PLOTTED: 3/20/2008 3:20/2008 2:47:02 PM

REVISION DATE: APRIL 1, 2001
 Computer File: T:\138200 E. Grand Blvd Bridge\DETAILS\208plde.dgn
 DATE PLOTTED: 3/20/2008
 TIME: 2:47:39 PM

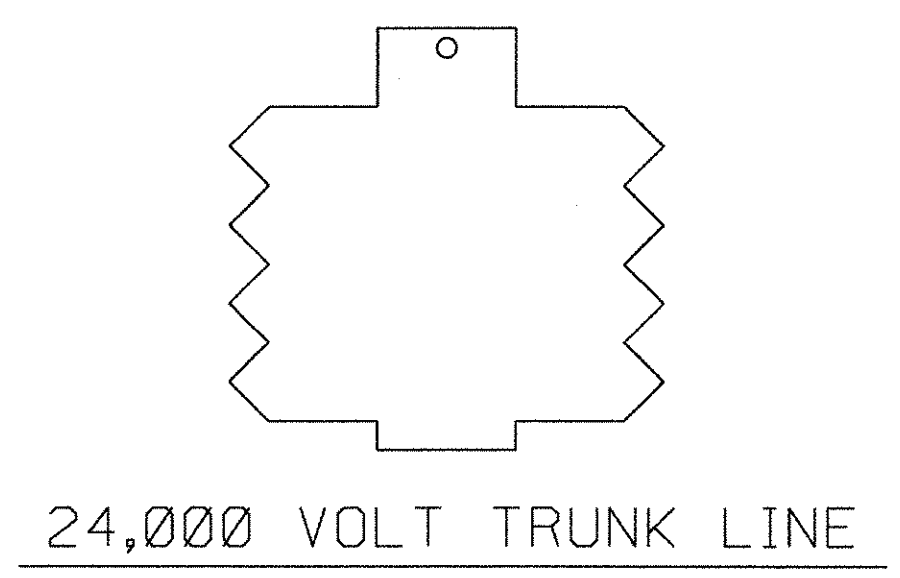

24,000 VOLT TRUNK LINE

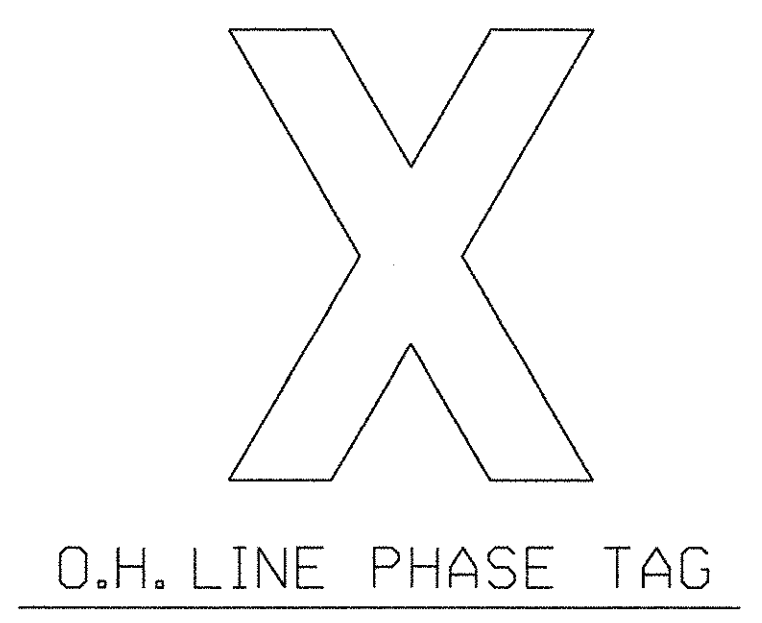

O.H. LINE PHASE TAG

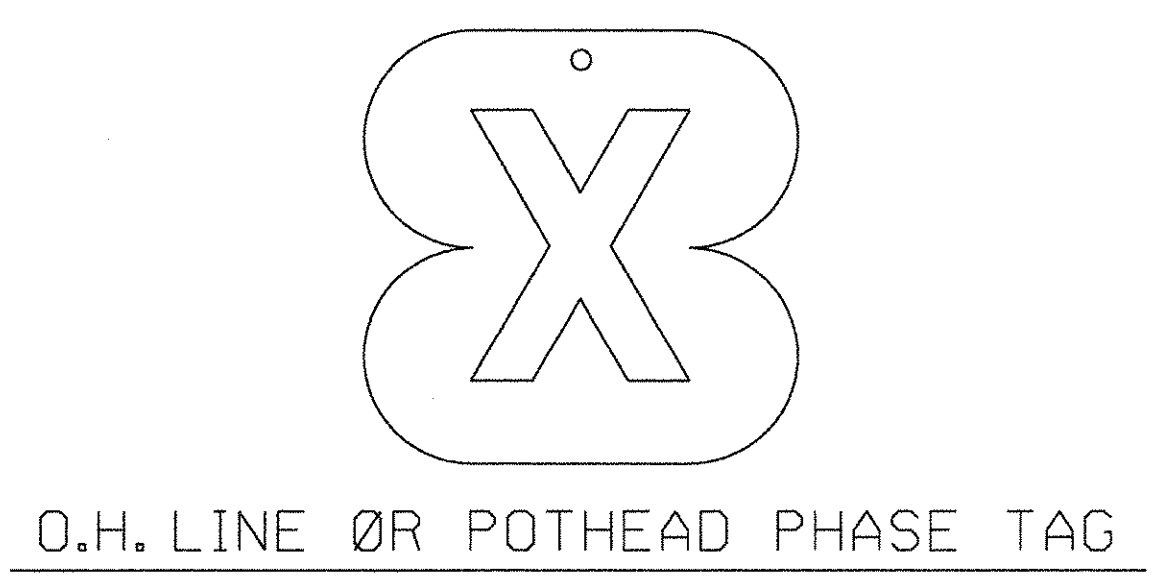

O.H. LINE ØR POTHEAD PHASE TAG

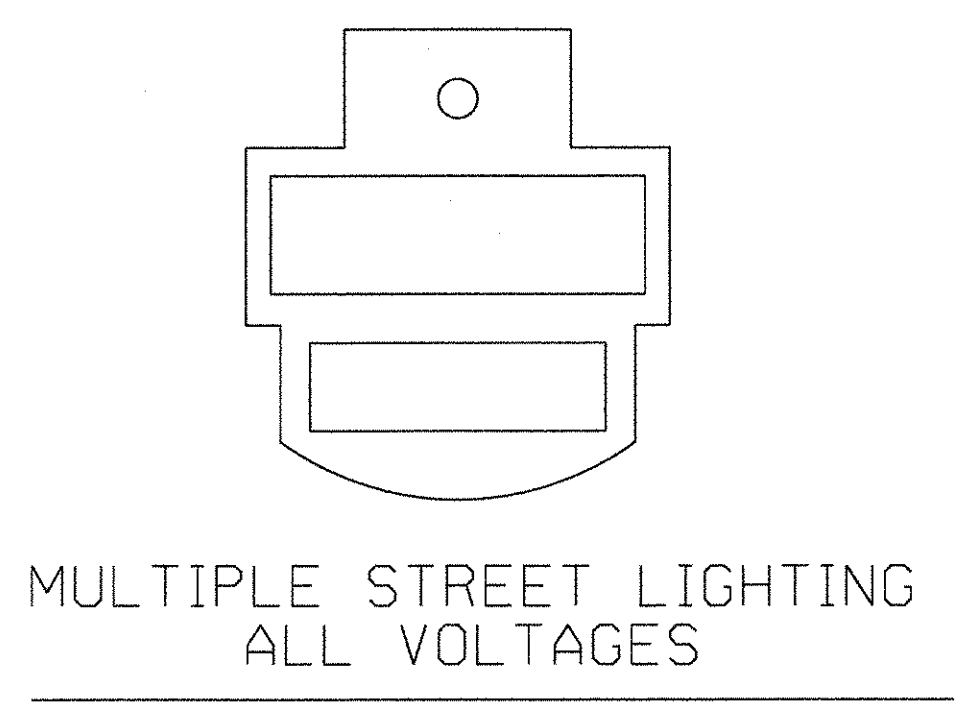

MULTIPLE STREET LIGHTING
ALL VOLTAGES

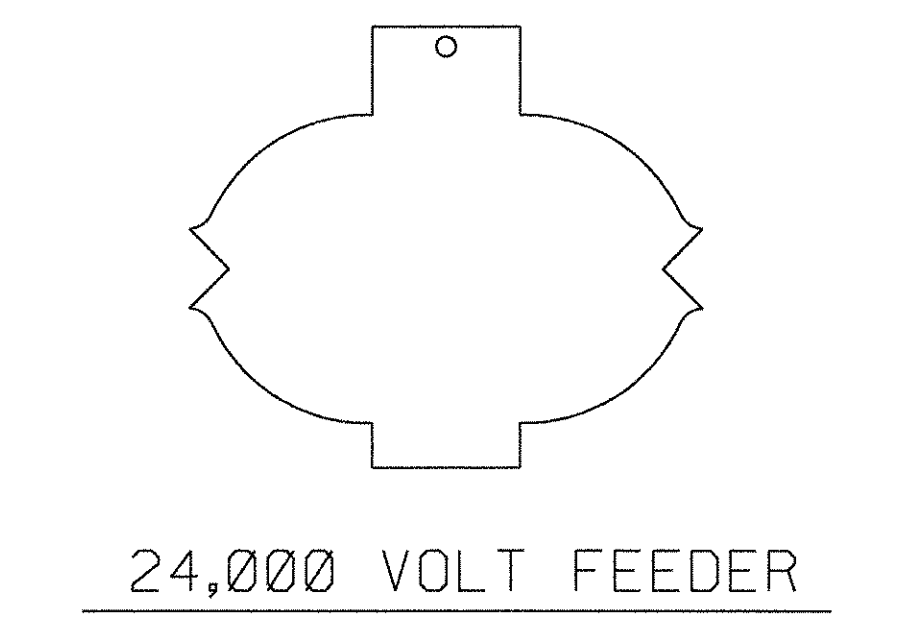

24,000 VOLT FEEDER

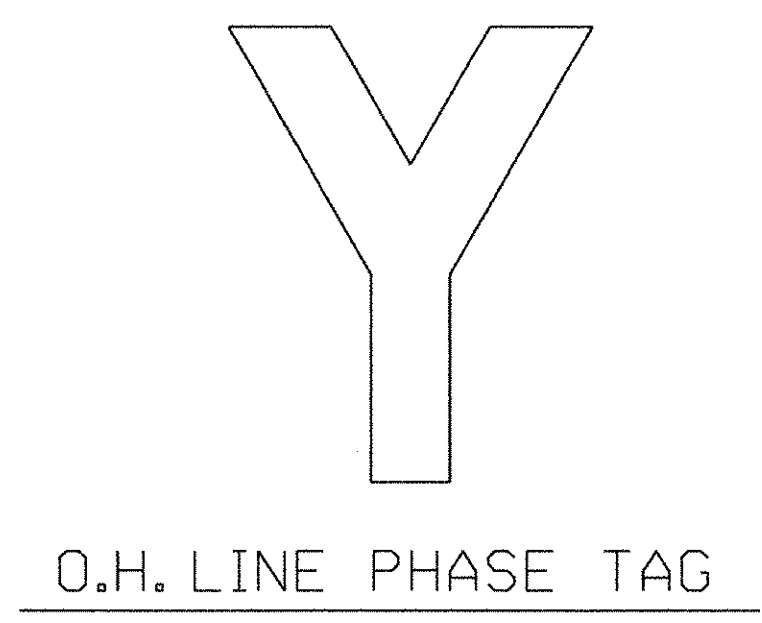

O.H. LINE PHASE TAG

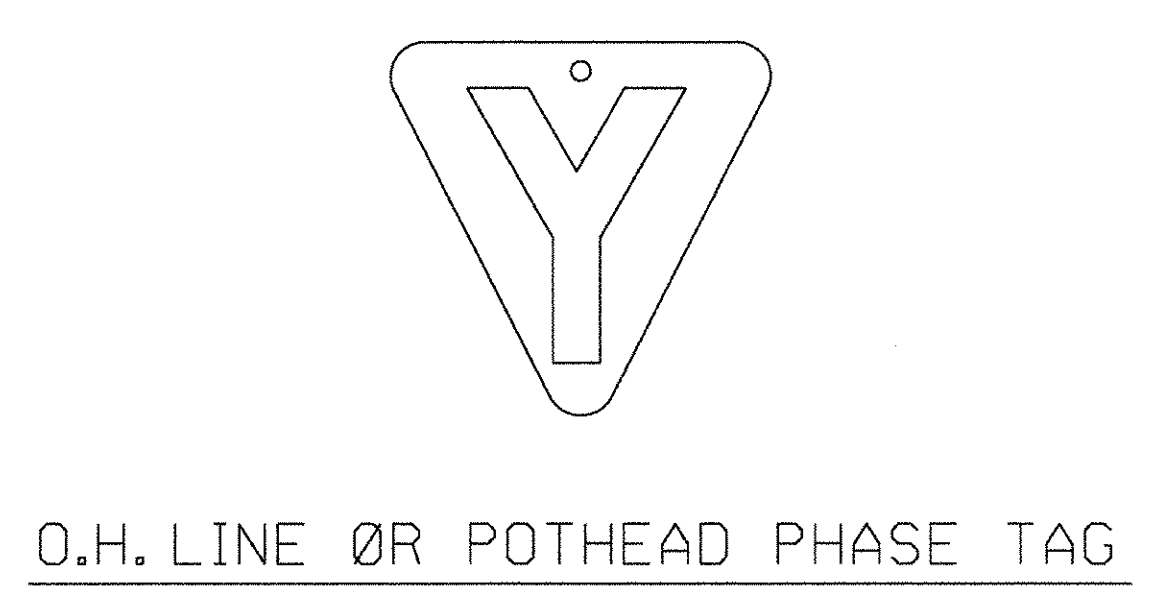

O.H. LINE ØR POTHEAD PHASE TAG

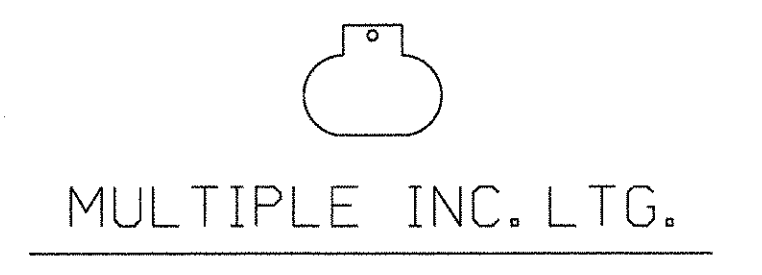

MULTIPLE INC. LTG.

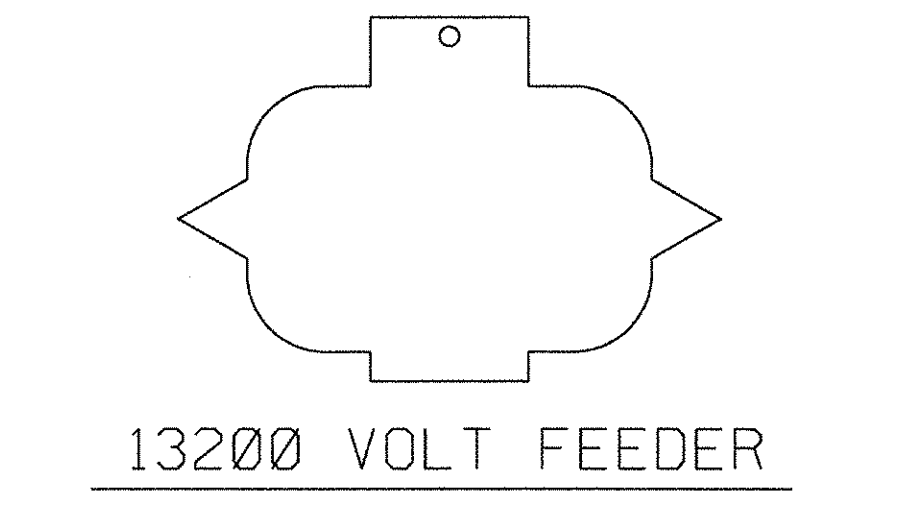

13200 VOLT FEEDER

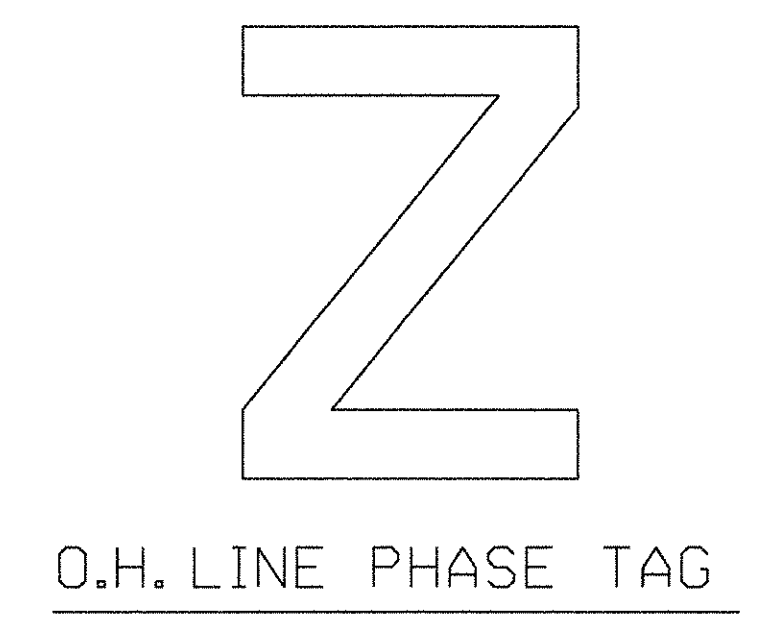

O.H. LINE PHASE TAG

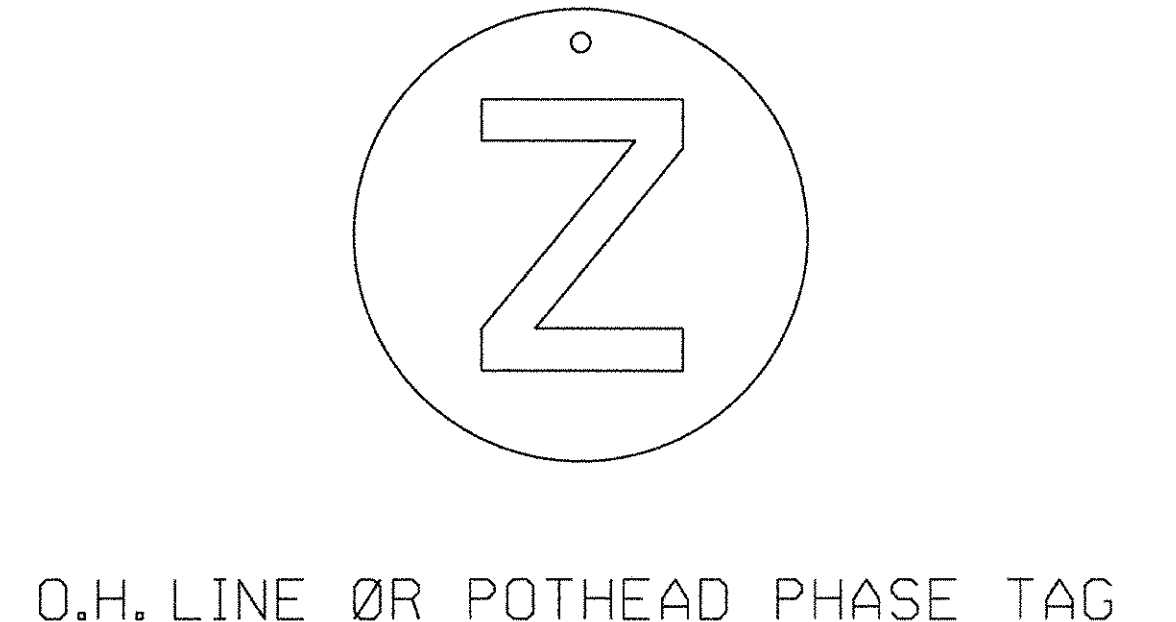

O.H. LINE ØR POTHEAD PHASE TAG

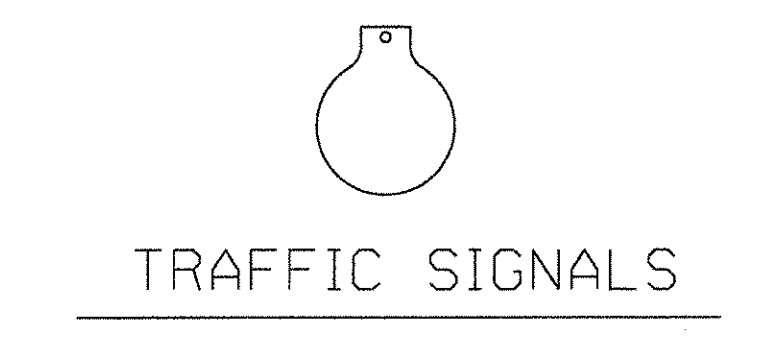

TRAFFIC SIGNALS

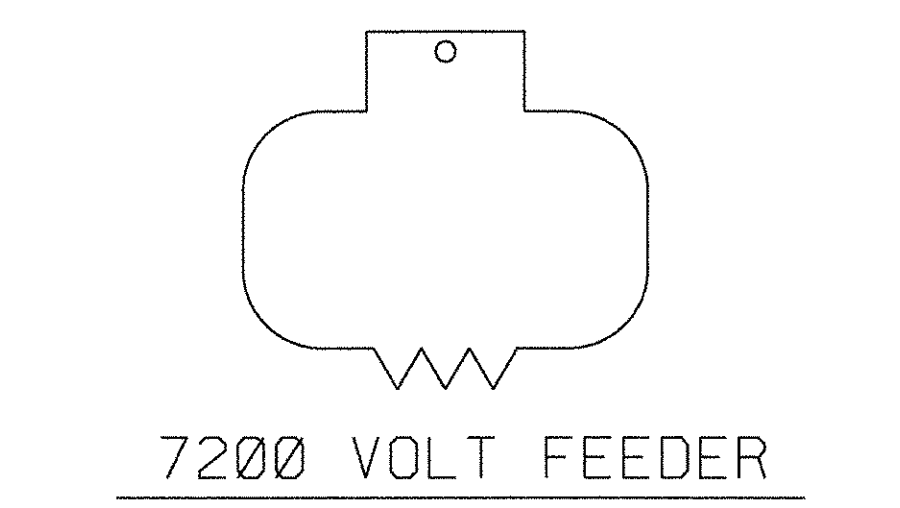

7200 VOLT FEEDER

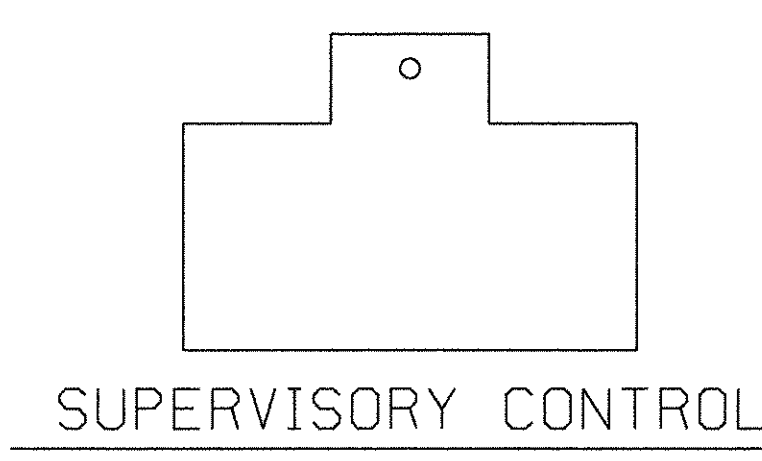

SUPERVISORY CONTROL

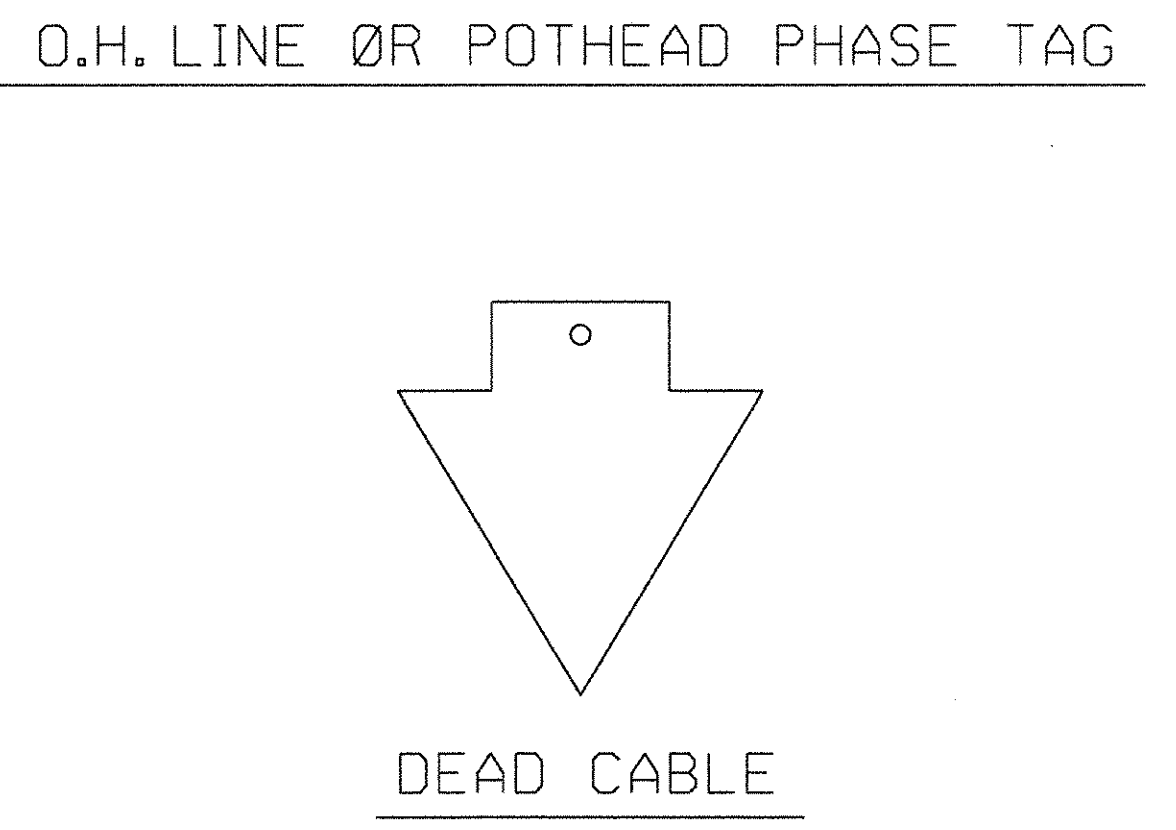

DEAD CABLE

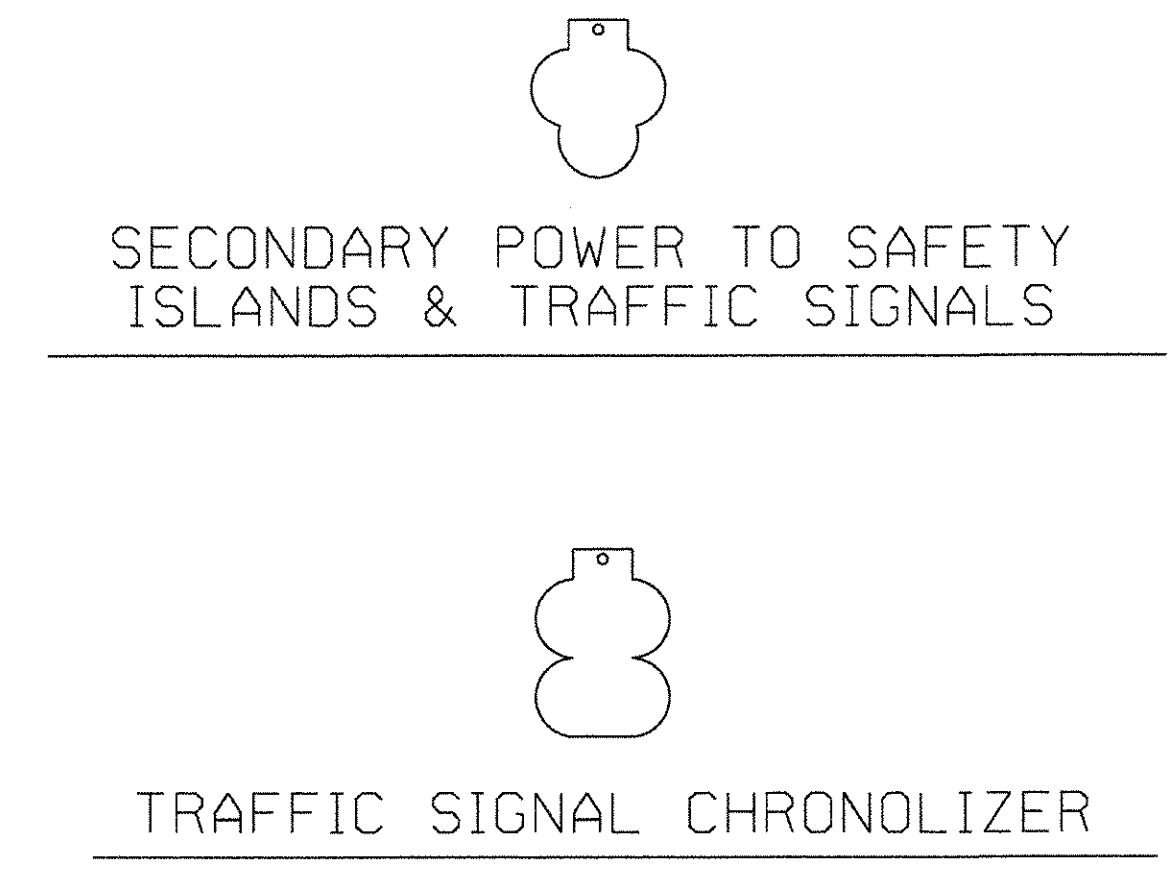

TRAFFIC SIGNAL CHRONOLIZER

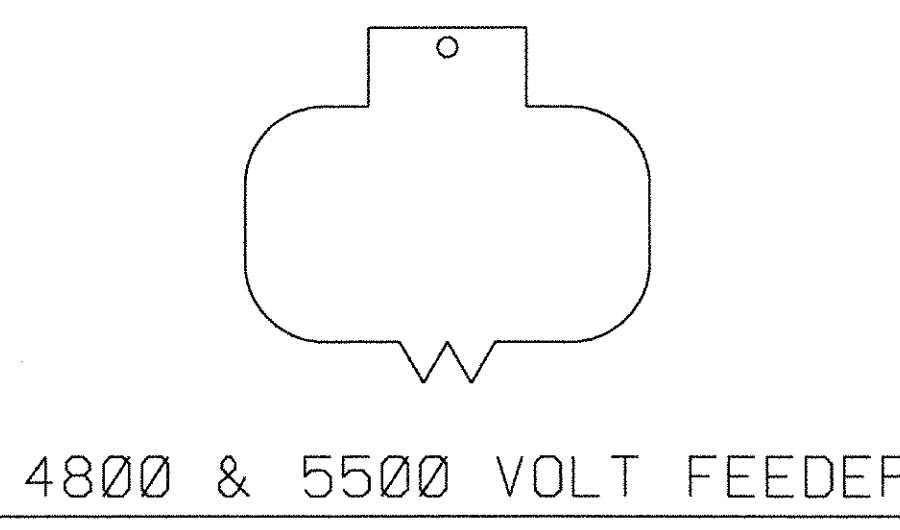

4800 & 5500 VOLT FEEDER

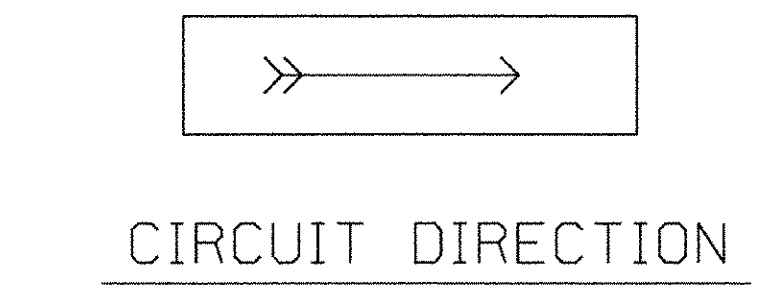

CIRCUIT DIRECTION

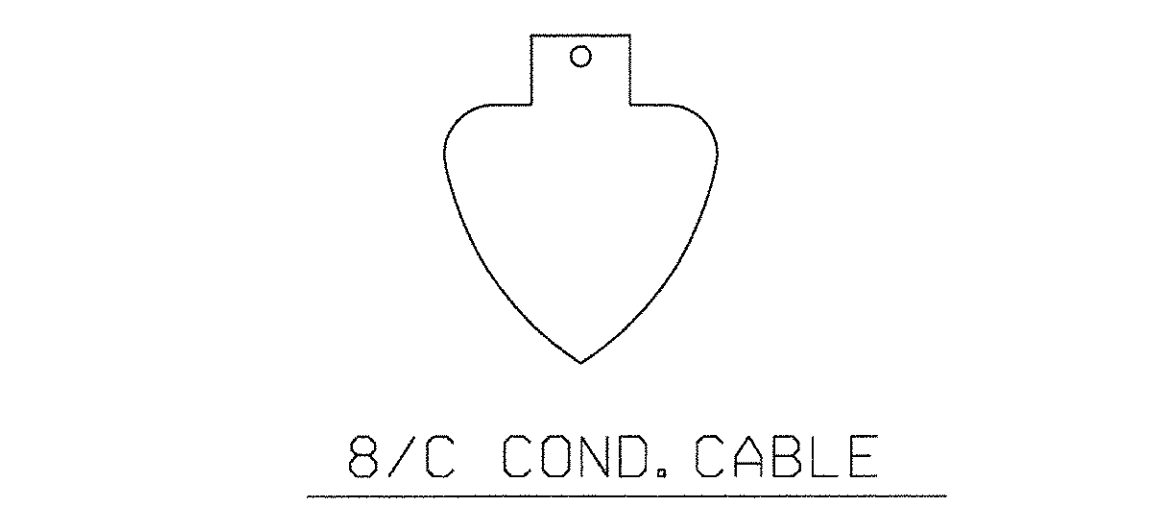

8/C COND. CABLE

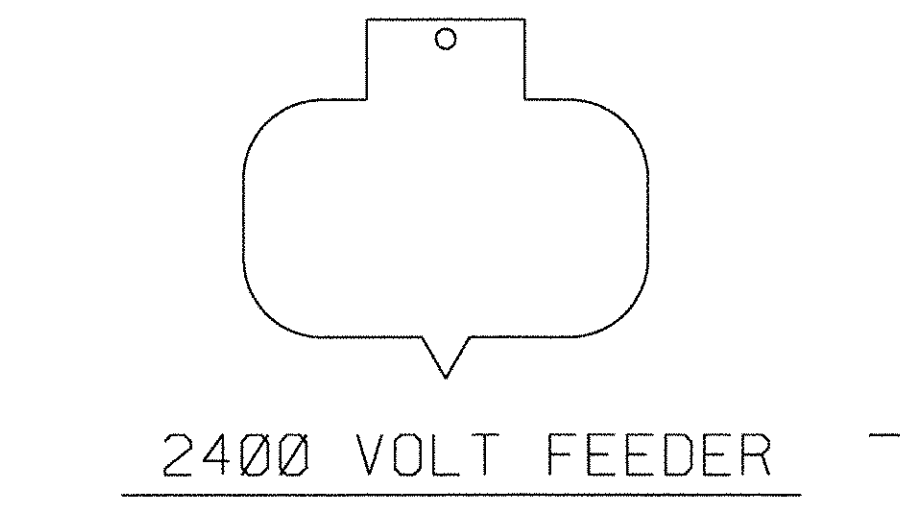

2400 VOLT FEEDER

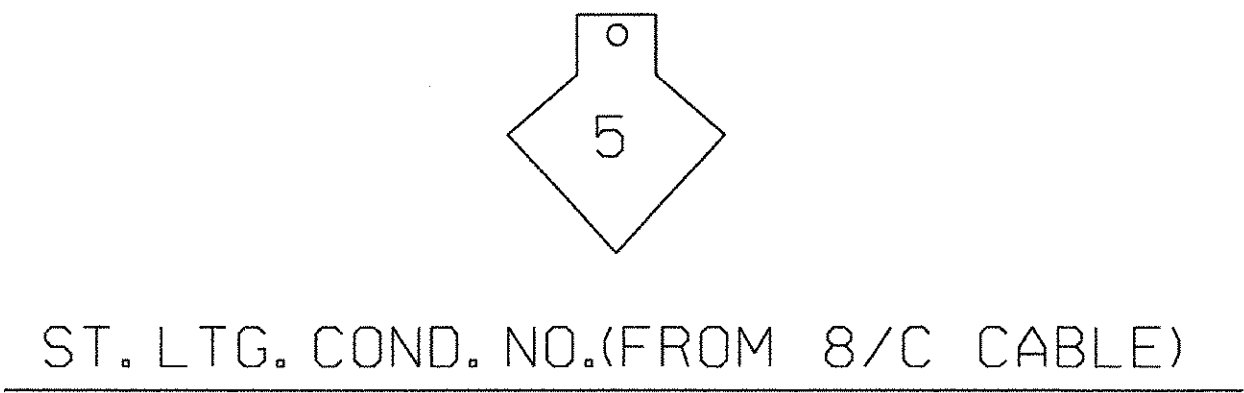

ST. LTG. COND. NO.(FROM 8/C CABLE)

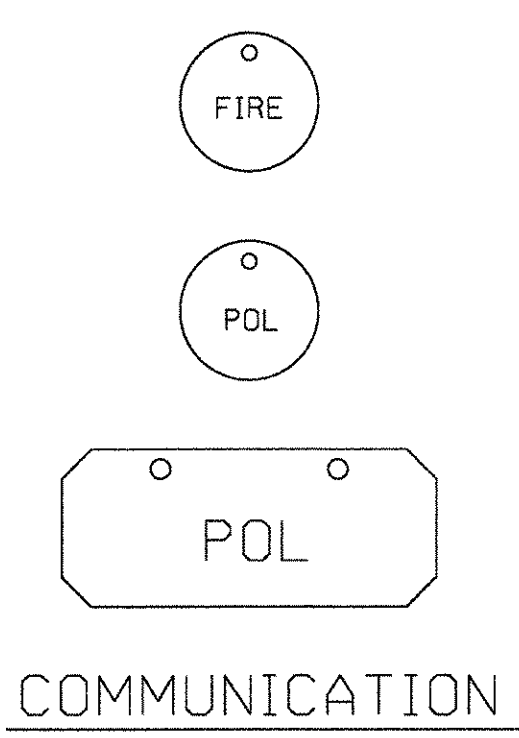

COMMUNICATION

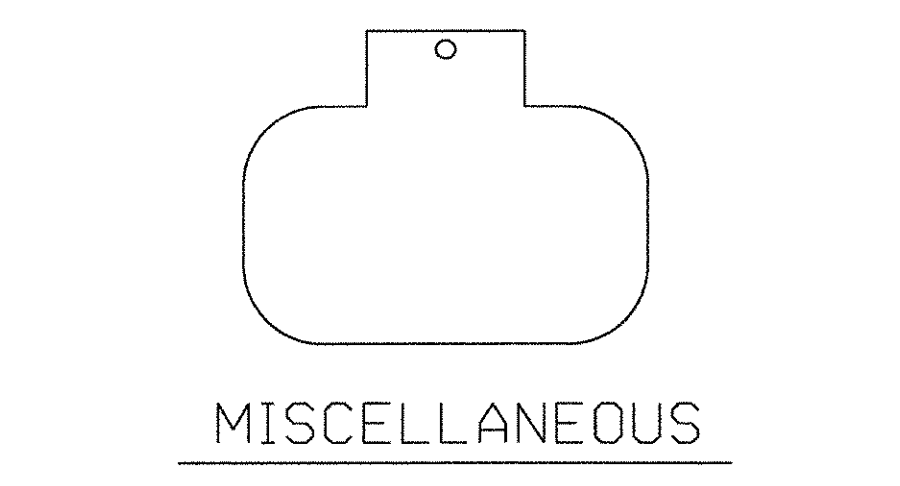

MISCELLANEOUS

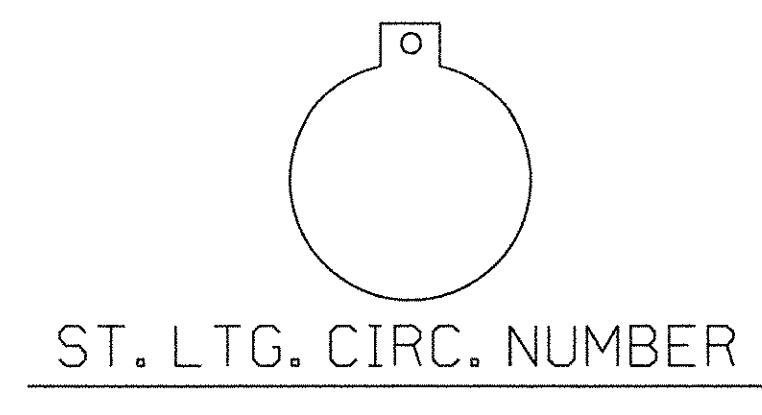

ST. LTG. CIRC. NUMBER

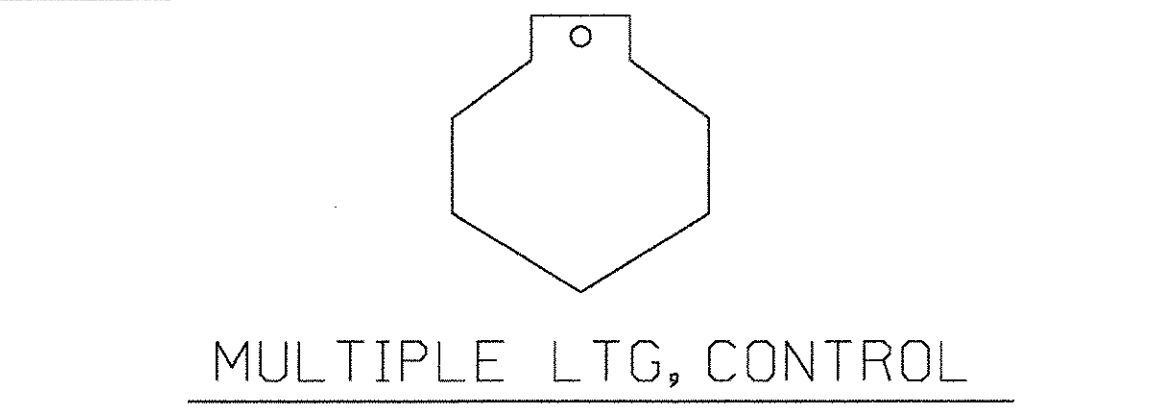

MULTIPLE LTG, CONTROL

IDENTIFICATION TAGS

MATERIAL : LEAD
(FOR REFERENCE)

SUBSTATION & CIRCUIT ABBREVIATIONS ON IDENTIFICATION TAGS SHALL BE SPELLED AS FOLLOWS

BEL.	KSG.	POR.
BUT.	LAB.	RUS.
CAN.	LEE.	STA.
COB.	LOT.	STO.
CON.	LUD.	TOW.
CUS.	MAP.	TRI.
GRF.	MCC.	TUR.
HUD.	MON.	WAL.
JSC.	PAL.	WSU.
JOY.	PHI.	JEF.

NOTE:

REQUIRED CABLE IDENTIFICATION TAGS WILL BE FURNISHED BY CONTRACTOR. CABLE TAG MARKINGS SUCH AS SUBSTATION OR CABLE MARKING WILL BE AS SHOWN ON PLANS OR WILL BE FURNISHED BY P.L.D.

CONTRACTOR SHALL FURNISH AND INSTALL CABLE TAGS AS PER P.L.D. SPECIFICATIONS.

SCALE : AS SHOWN		
REVISIONS		
Date	Description	Chkd. by

DETAILS
EAST GRAND BOULEVARD BRIDGE
CABLE TAGS DETAILS



Checked by			Approved by		
Checked by			Approved by		
Checked by			File No.		
			51-0686		

Consulting Engineering Associates, Inc.
16580 WYOMING AVE. DETROIT MICHIGAN 48221
TELEPHONE: (313) 341-5787 FAX: 341-0205

Designed by	Checked by	Sheet No.
C. E. A.		54 of 60
Disk File Name	Job File No.	
208PLDM	CEA 138200	
Date	Dwg. No.	
3-03-08	DTL-2-	

TIME: 2:48:11 PM
 DATE PLOTTED: 3/20/2008
 REVISION DATE: APRIL 1, 2001
 Computer File: T:\138200 E. Grand Blvd Bridge\DETAILS\301plde.dgn

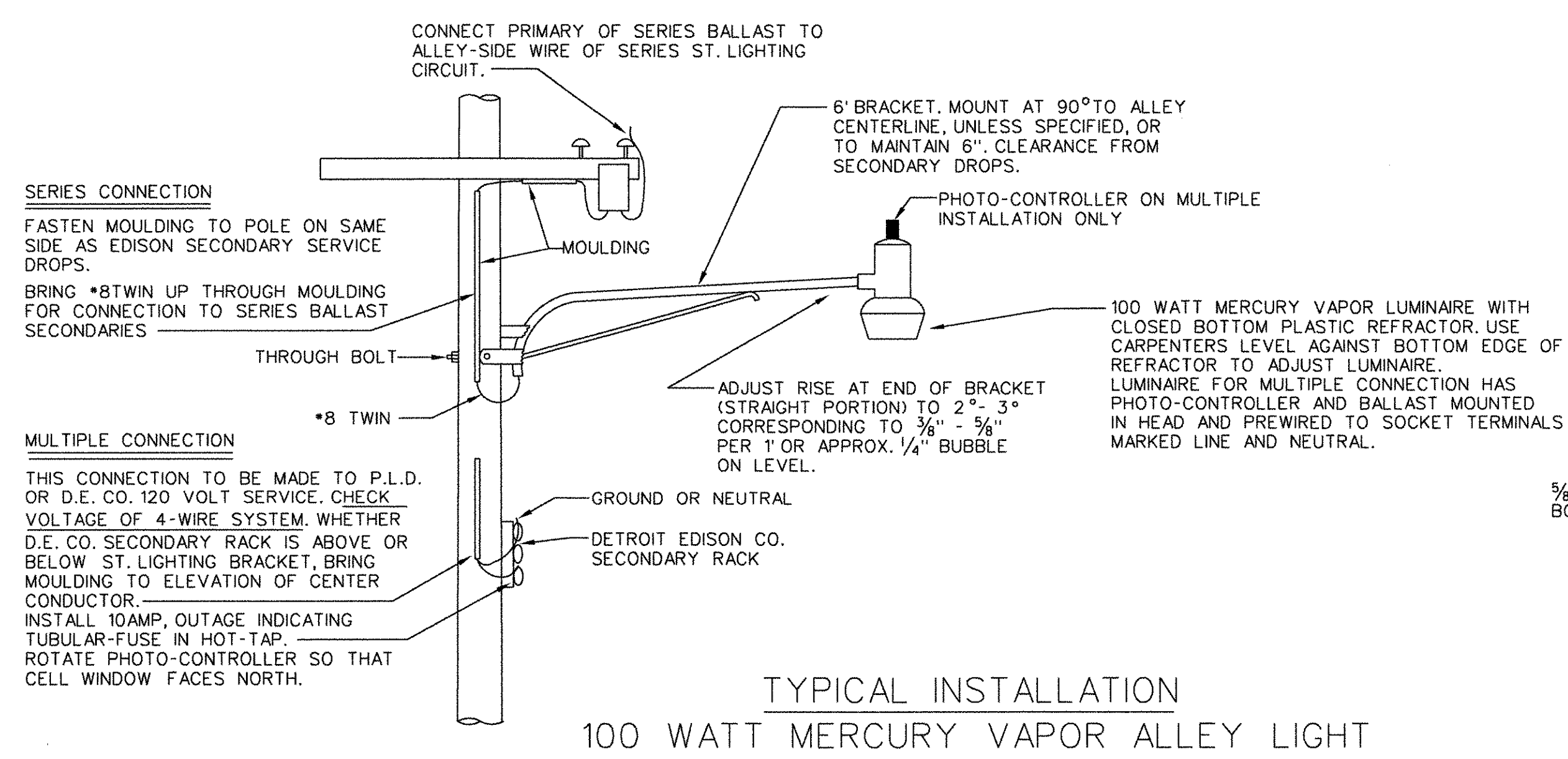

TYPICAL INSTALLATION
 100 WATT MERCURY VAPOR ALLEY LIGHT

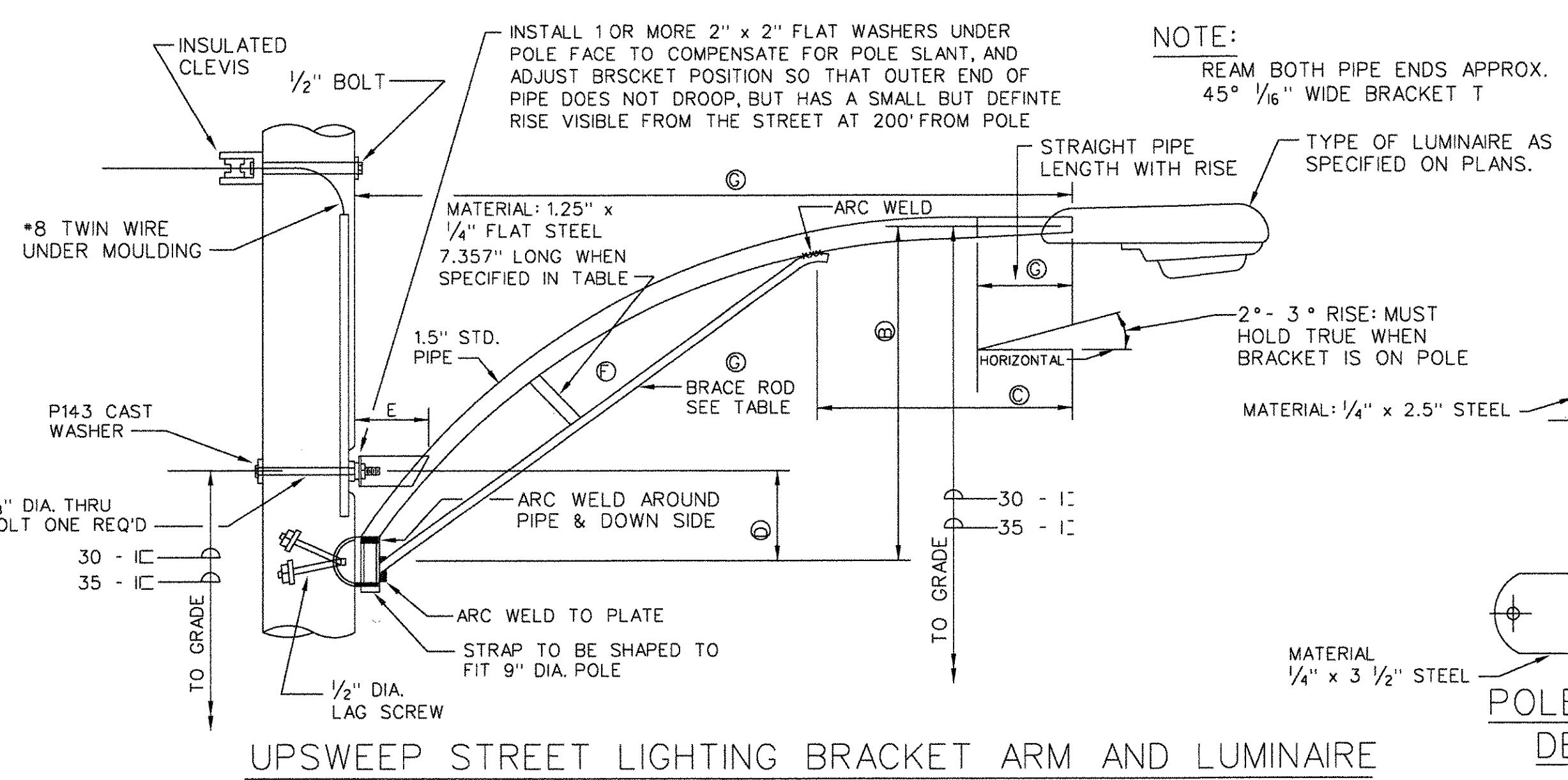

UPSWEPT STREET LIGHTING BRACKET ARM AND LUMINAIRE

TYPE	A	B	C	D	E	F	G	H
6'	6'	32"	2.4'	8.75"	5.5"	NO	1" SOLID	14"
8'	92"	4'	3'	8.75"	4.5"	YES	1" SOLID	8"
10'	122"	3.3'	3.4"	8.875"	8"	NO	1" SOLID	2"

THIS DIMENSION IS APPROXIMATE

30' LUM. MOUNTING HEIGHT				35' LUM. MOUNTING HEIGHT			
ARM LENGTH		ARM LENGTH		ARM LENGTH		ARM LENGTH	
6'	8'	10'	30'	6'	8'	10'	35'
30 - I	30'	30'	30'	35 - I	35'	35'	35'
30 - II	26'-3"	26'-3"	35 - II	31'-3"	33'-0"		

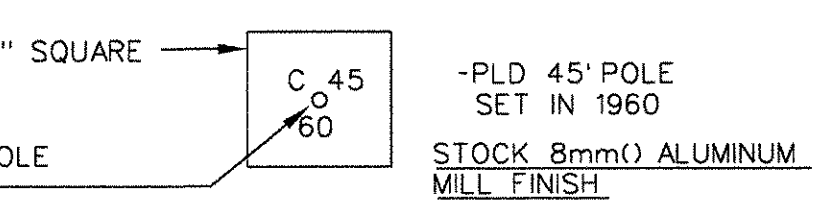

TYPICAL MARKING
 WOOD POLE TAGS

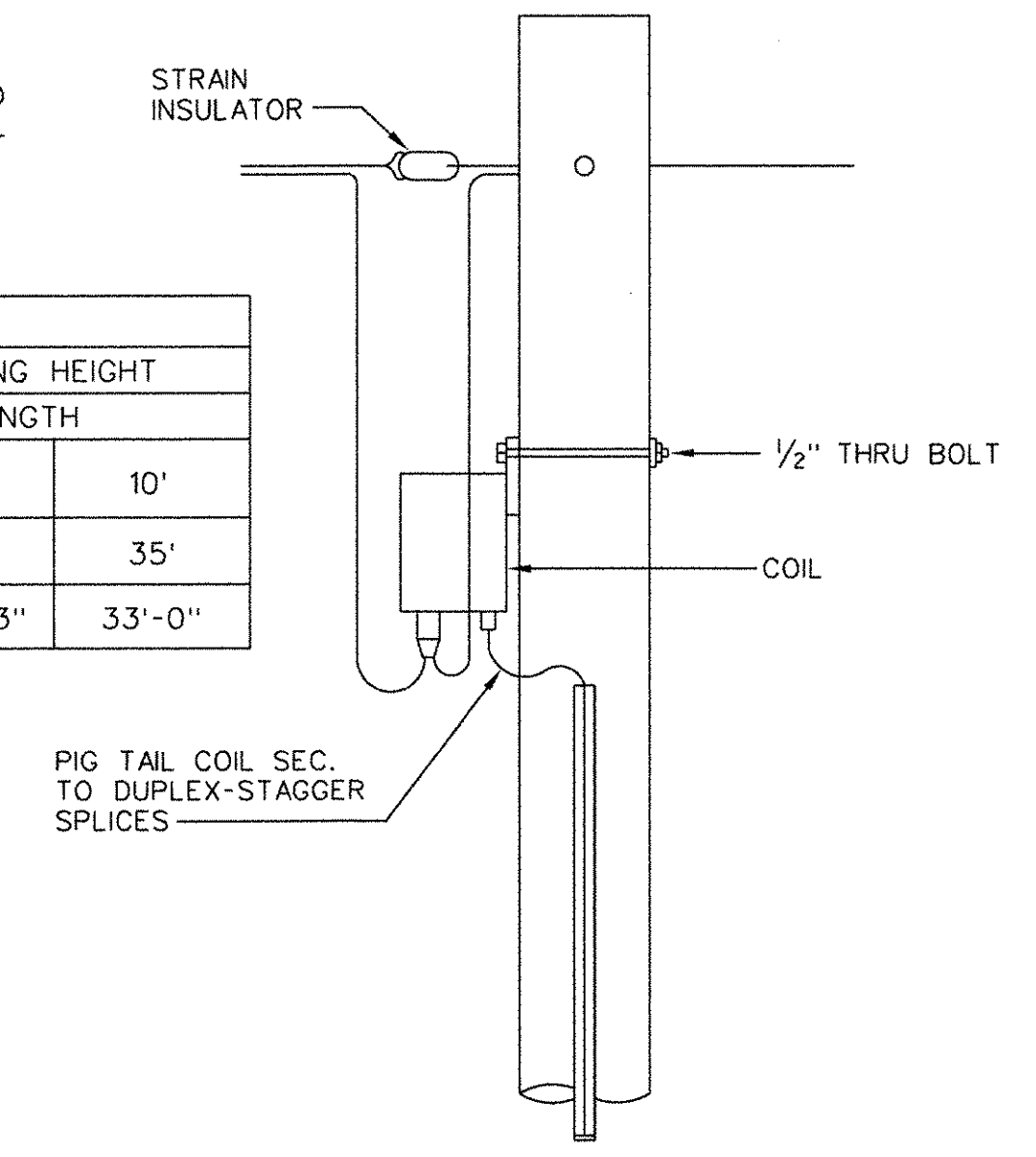

TYPICAL COIL INSTALLATION

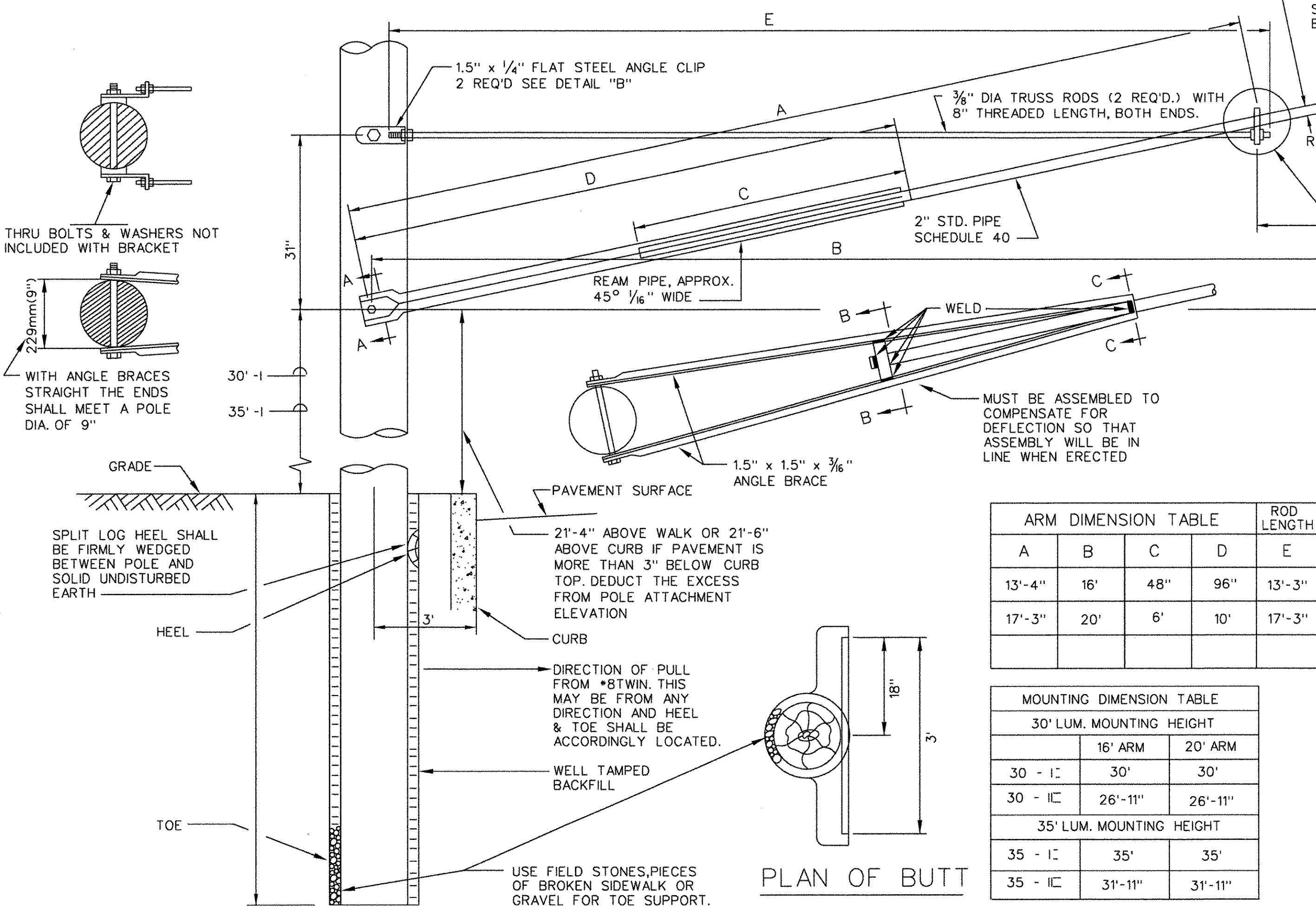

ELEVATION
 N.T.S.

PLAN OF BUTT

A	B	C	D	E	ROD LENGTH
13'-4"	16'	48"	96"	13'-3"	
17'-3"	20'	6'	10'	17'-3"	

30' LUM. MOUNTING HEIGHT		35' LUM. MOUNTING HEIGHT	
30' LUM. MOUNTING HEIGHT	20' ARM	20' ARM	30'
30 - I	30'	30'	30'
30 - II	26'-11"	26'-11"	
35 - I	35'	35'	
35 - II	31'-11"	31'-11"	

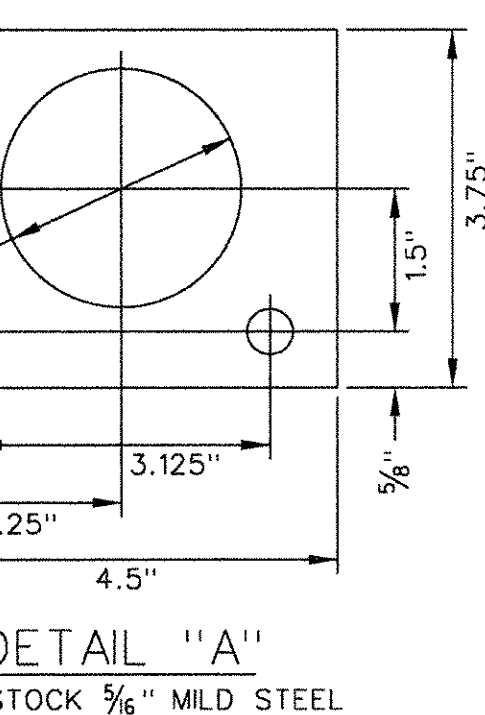

DETAIL "A"
 STOCK 5/8" MILD STEEL

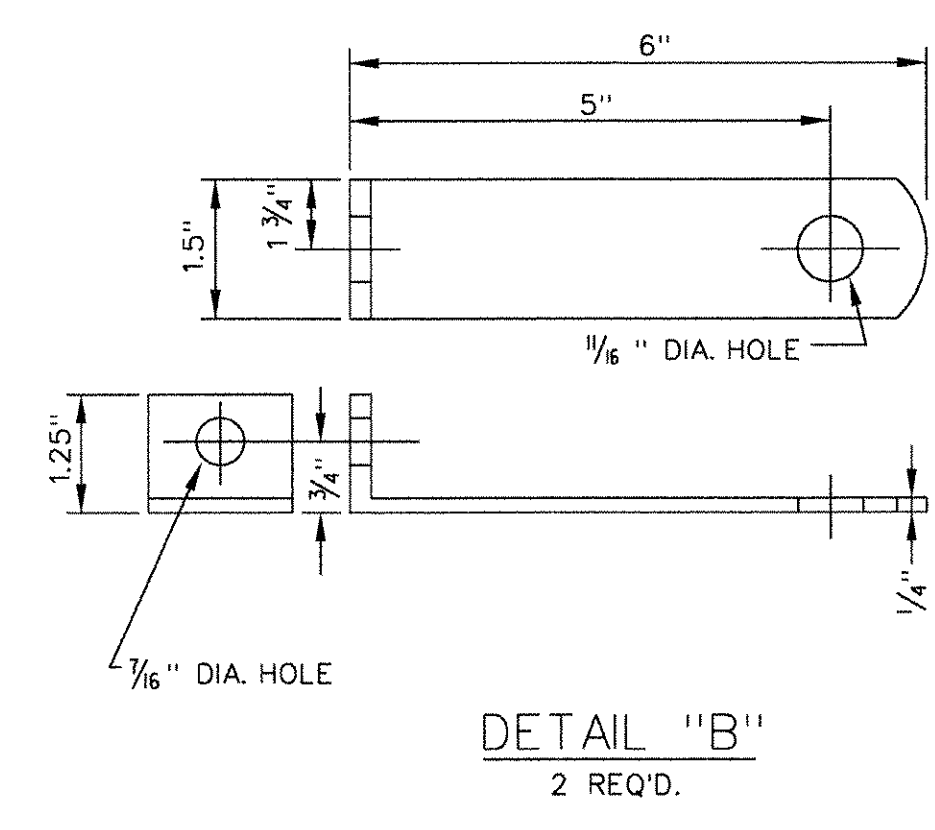

DETAIL "B"
 2 REQ'D.

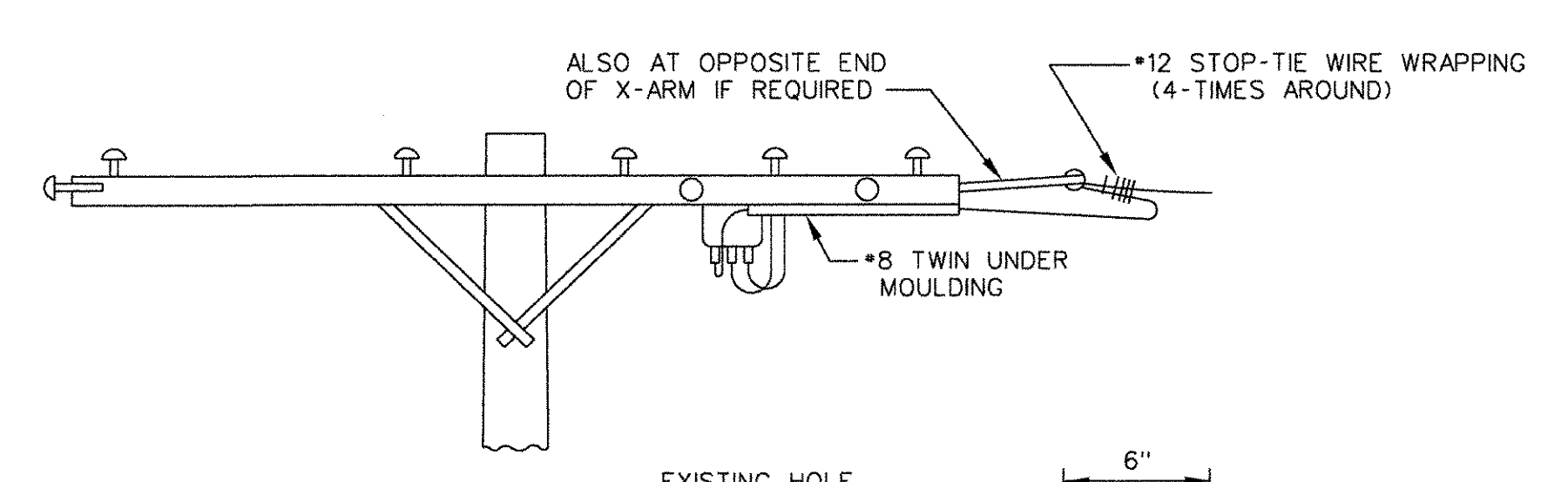

END OF ARM CONSTRUCTION FOR STREET LIGHTING

REVISIONS		
Date	Description	Chkd. by

SCALE: AS SHOWN

DETAILS
 EAST GRAND BOULEVARD BRIDGE

MISCELLANEOUS OVERHEAD

CITY OF DETROIT
 DEPARTMENT OF PUBLIC WORKS

Checked by _____ Approved by _____

PUBLIC LIGHTING DEPARTMENT
 CITY OF DETROIT

Checked by _____ Approved by _____ File No. 51-0686

Consulting Engineering Associates, Inc.
 16580 WYOMING AVE. DETROIT MICHIGAN 48221
 TELEPHONE: (313) 341-5797 FAX: 341-0205

Designed by C.E.A. Checked by _____ Sheet No. 55 of 60

Disk File Name Job File No. 301PLDM CEA 138200
 Date 3-03-08 Dwg. No. DTL-2-

* MAXIMUM LANDING SLOPE IN ANY DIRECTION IS 2.0%.
MINIMUM LANDING DIMENSIONS 5' x 5'.

** MAXIMUM CROSS SLOPE ON RAMP IS THE SAME AS THAT FOR SIDEWALK (2.0%).
RUNNING SLOPE 5% - 7% (8.3% MAXIMUM).

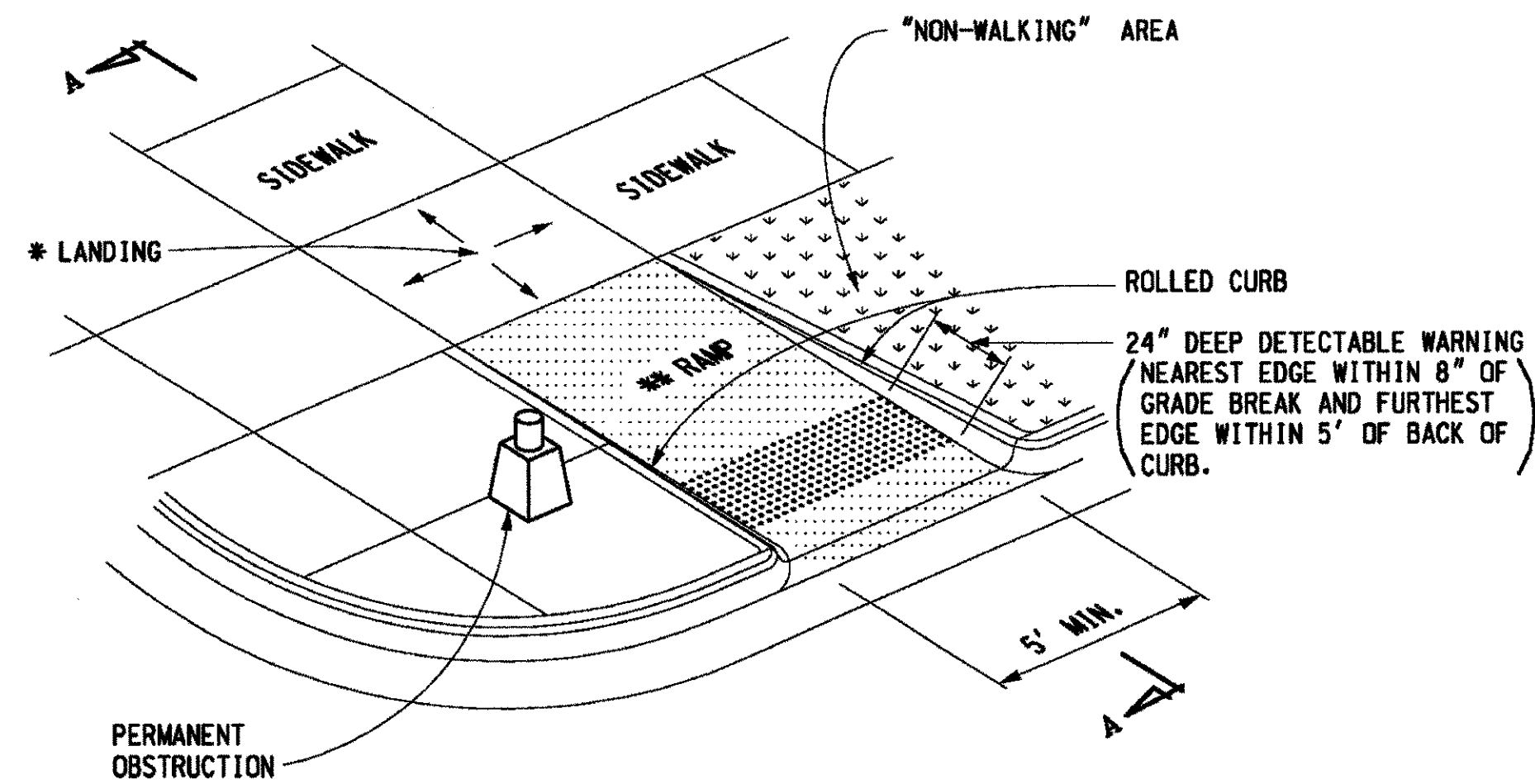

SIDEWALK RAMP TYPE R
(ROLLED SIDES)

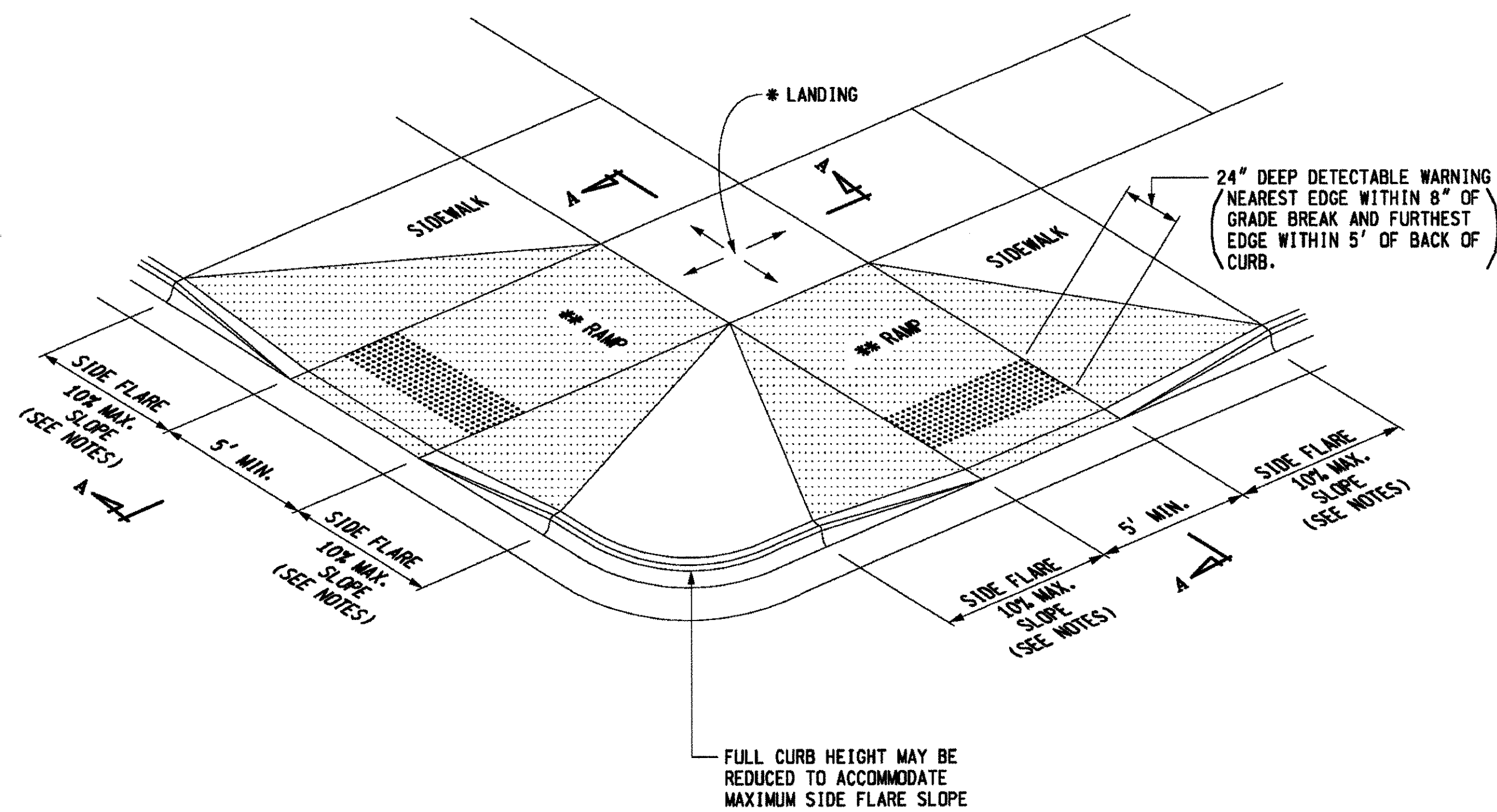

SIDEWALK RAMP TYPE F
(FLARED SIDES, TWO RAMPS SHOWN)

* MAXIMUM LANDING SLOPE IN ANY DIRECTION IS 2.0%.
MINIMUM LANDING DIMENSIONS 5' x 5'.

** MAXIMUM CROSS SLOPE ON RAMP IS THE SAME AS THAT FOR SIDEWALK (2.0%).
RUNNING SLOPE 5% - 7% (8.3% MAXIMUM).

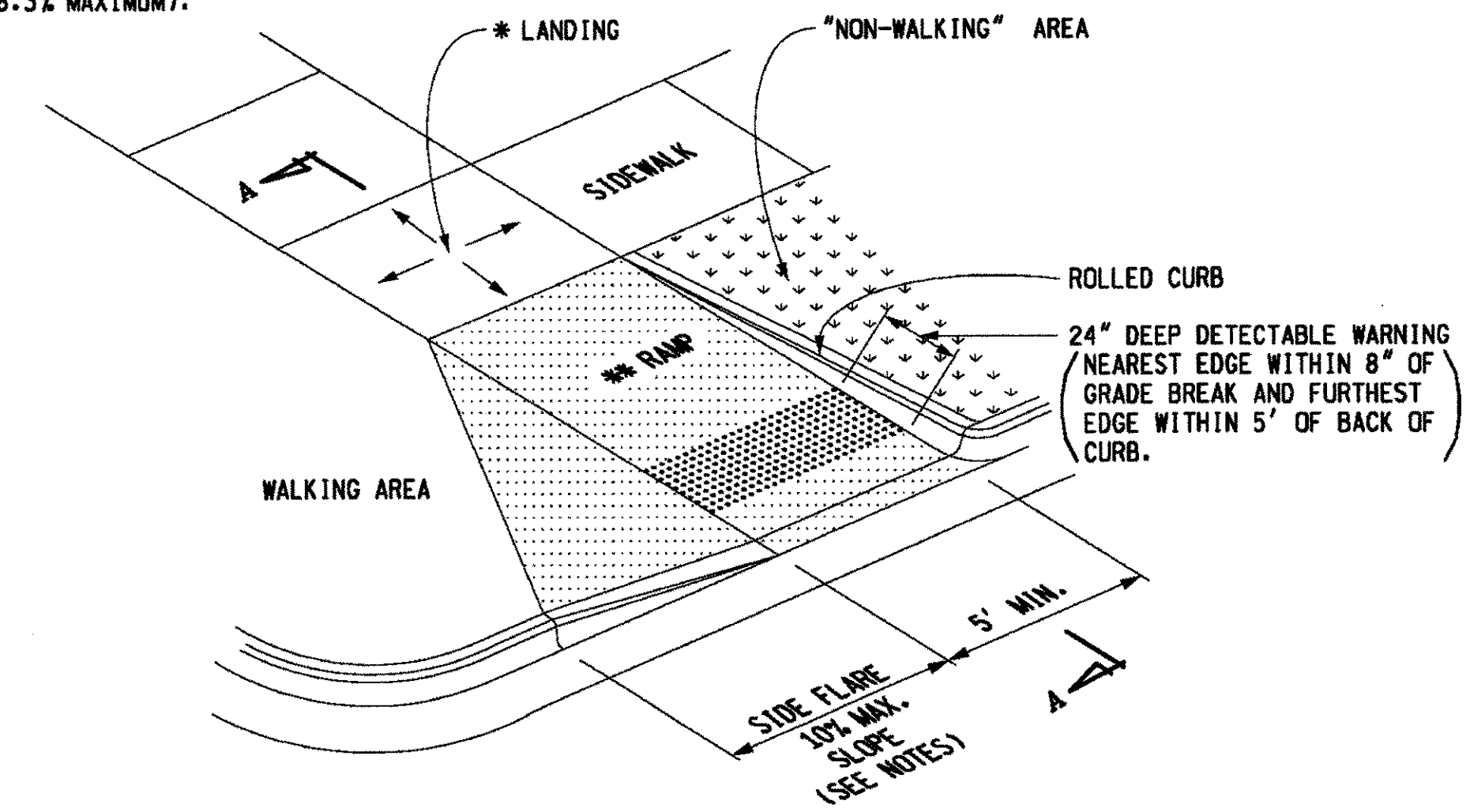

SIDEWALK RAMP TYPE RF
(ROLLED / FLARED SIDES)

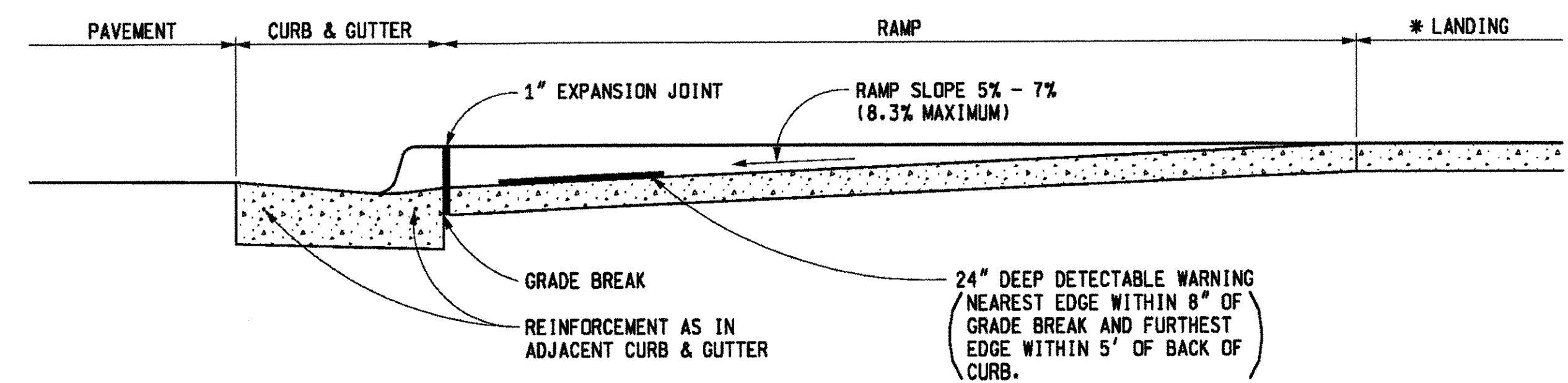

SECTION A-A
(TYPICAL ALL RAMP DETAILS)

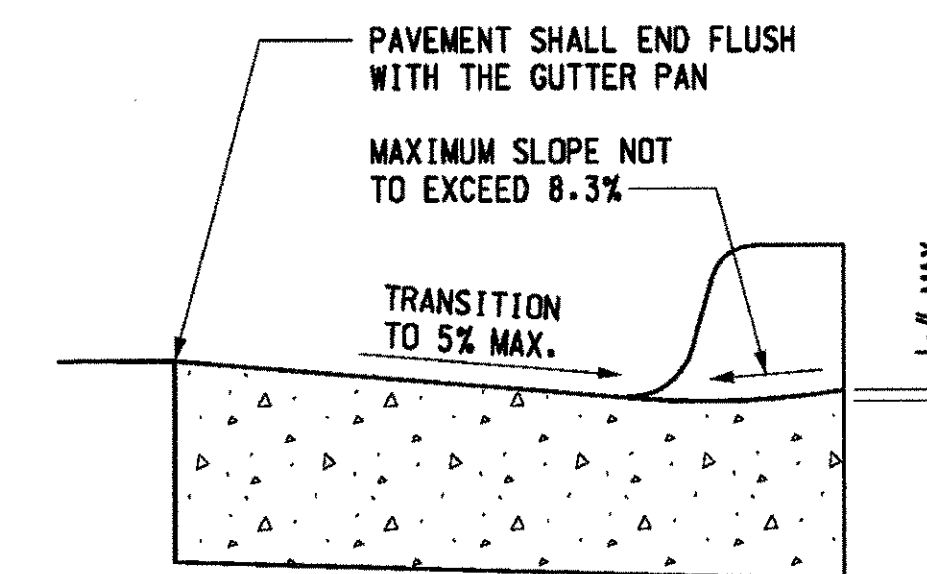

SECTION THROUGH CURB CUT
(TYPICAL ALL RAMP TYPES)



PREPARED BY
DESIGN DIVISION
DRAWN BY: B.L.T.
CHECKED BY: W.K.P.

DEPARTMENT DIRECTOR
Kirk T. Stuedle

APPROVED BY: _____
ENGINEER OF DELIVERY

APPROVED BY: _____
ENGINEER OF DEVELOPMENT

MICHIGAN DEPARTMENT OF TRANSPORTATION
BUREAU OF HIGHWAY DEVELOPMENT STANDARD PLAN FOR

**SIDEWALK RAMP AND
DETECTABLE WARNING DETAILS**

F.H.W.A. APPROVAL PLAN DATE 2-19-2008 R-28-F SHEET 1 OF 7

MICHIGAN DEPARTMENT OF TRANSPORTATION
BUREAU OF HIGHWAY DEVELOPMENT STANDARD PLAN FOR

**SIDEWALK RAMP AND
DETECTABLE WARNING DETAILS**

F.H.W.A. APPROVAL PLAN DATE 2-19-2008 R-28-F SHEET 2 OF 7

CONTROL SECTION STU 82400 JOB NO. 86173A SHEET NO. 56

* MAXIMUM LANDING SLOPE IN ANY DIRECTION IS 2.0%.
MINIMUM LANDING DIMENSIONS 5' x 5'.
** MAXIMUM CROSS SLOPE ON RAMP IS THE SAME AS THAT
FOR SIDEWALK (2.0%).
RUNNING SLOPE 5% - 7% (8.3% MAXIMUM).

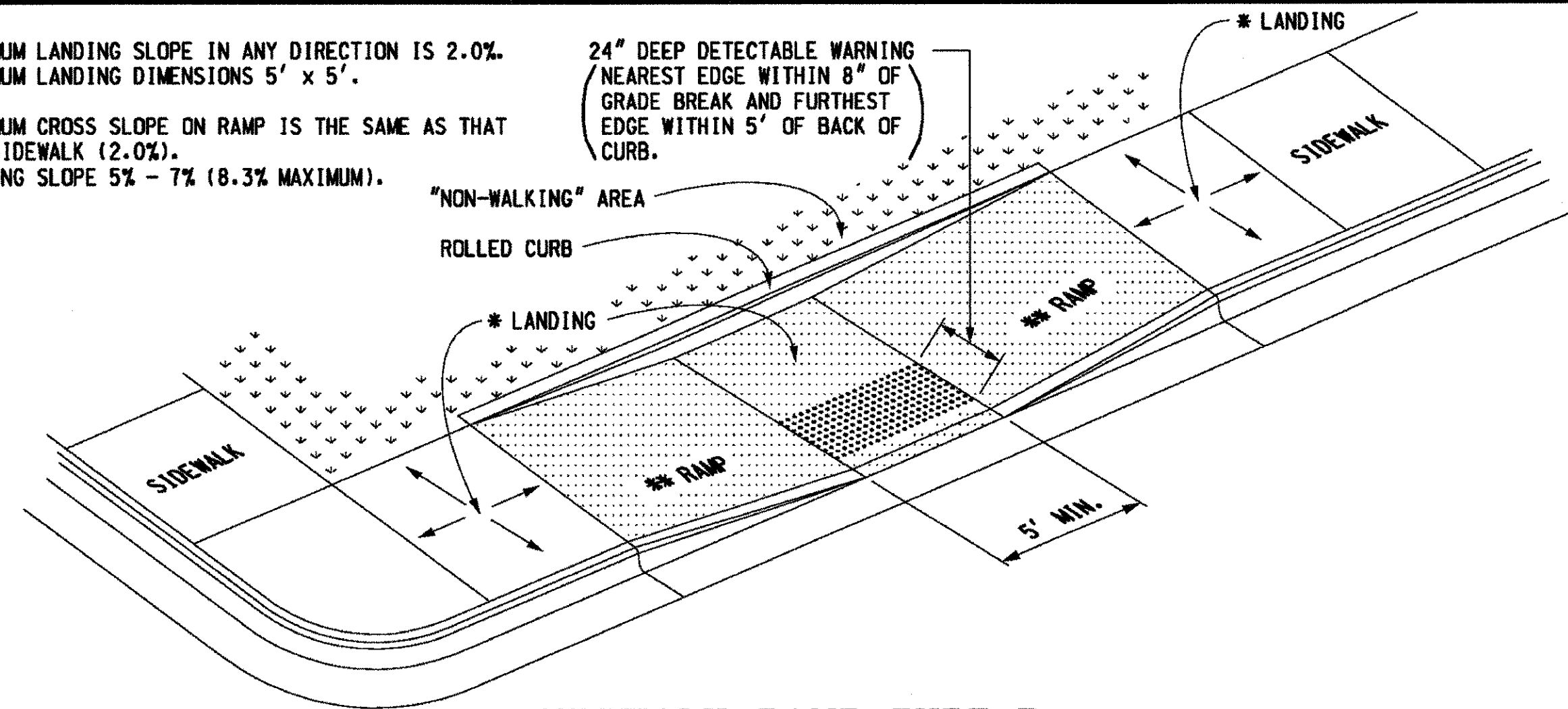

SIDEWALK RAMP TYPE P

(PARALLEL RAMP)
DO NOT USE IN AREAS WHERE PONDING MAY OCCUR

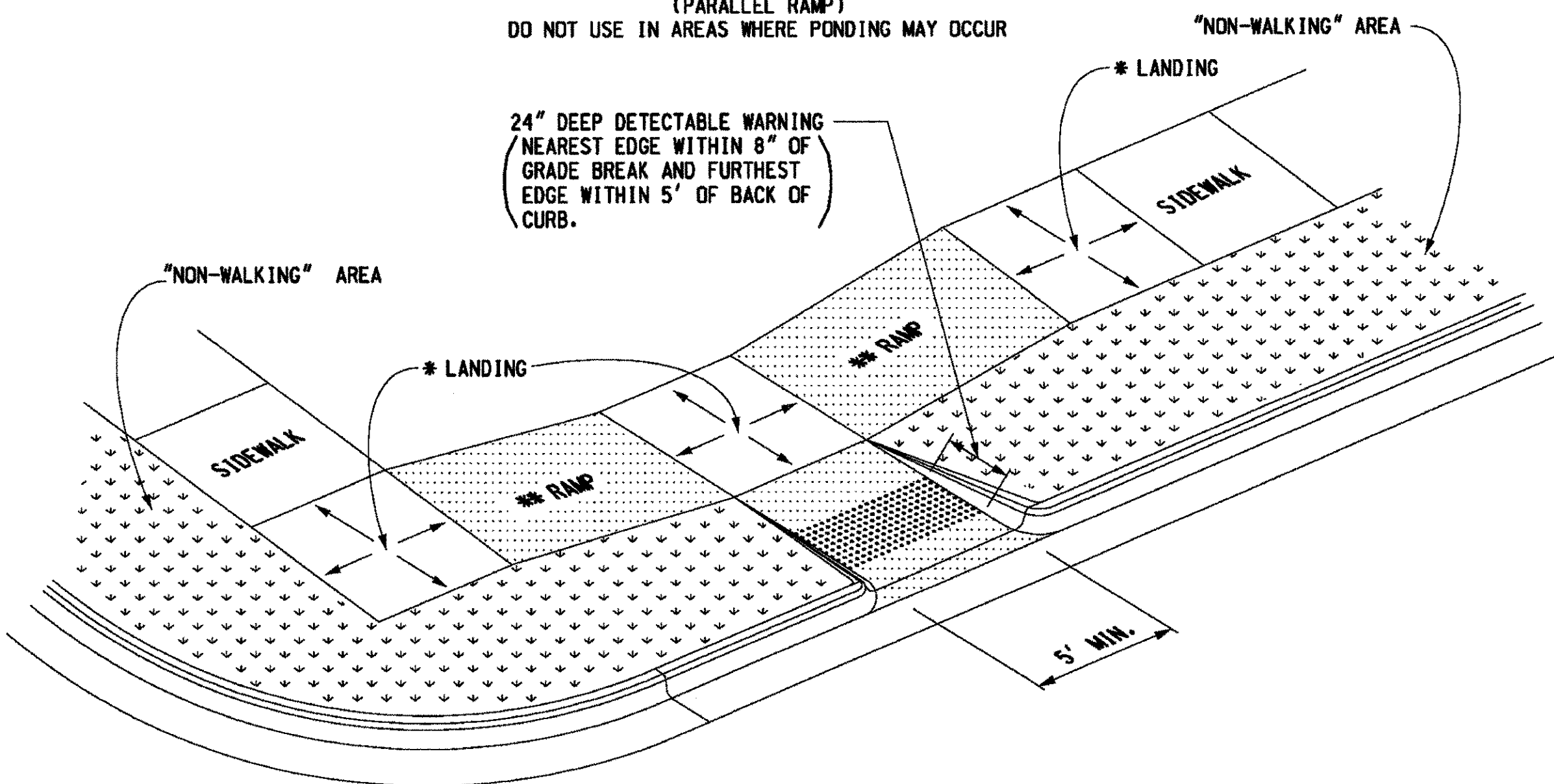

SIDEWALK RAMP TYPE C

(COMBINATION RAMP)

USE 24" DEEP DETECTABLE WARNINGS IF MEDIAN
WIDTH IS AT LEAST 6'-0". OTHERWISE NO
DETECTABLE WARNING IS REQUIRED.

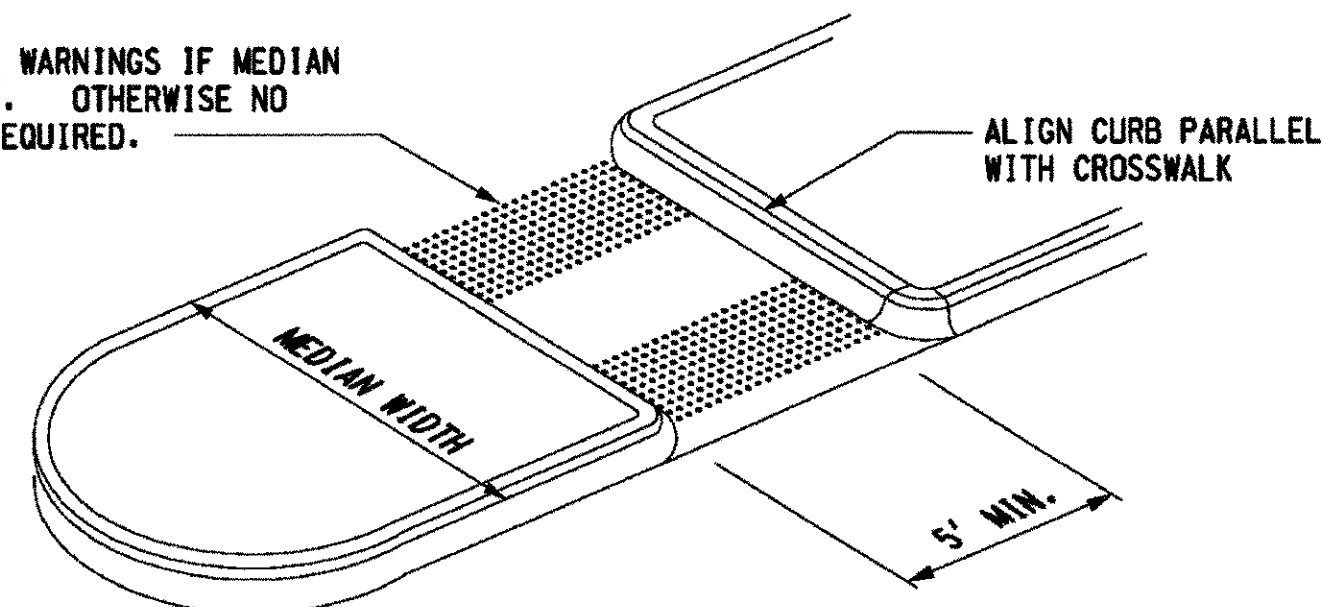

SIDEWALK RAMP TYPE M

(MEDIAN ISLAND)

MICHIGAN DEPARTMENT OF TRANSPORTATION
BUREAU OF HIGHWAY DEVELOPMENT STANDARD PLAN FOR

**SIDEWALK RAMP AND
DETECTABLE WARNING DETAILS**

F.H.W.A. APPROVAL	2-19-2008 PLAN DATE	R-28-F	SHEET 3 OF 7
-------------------	------------------------	--------	-----------------

* MAXIMUM LANDING SLOPE IN ANY DIRECTION IS 2.0%.
MINIMUM LANDING DIMENSIONS 5' x 5'.
** MAXIMUM CROSS SLOPE ON RAMP IS THE SAME AS THAT
FOR SIDEWALK (2.0%).
RUNNING SLOPE 5% - 7% (8.3% MAXIMUM).

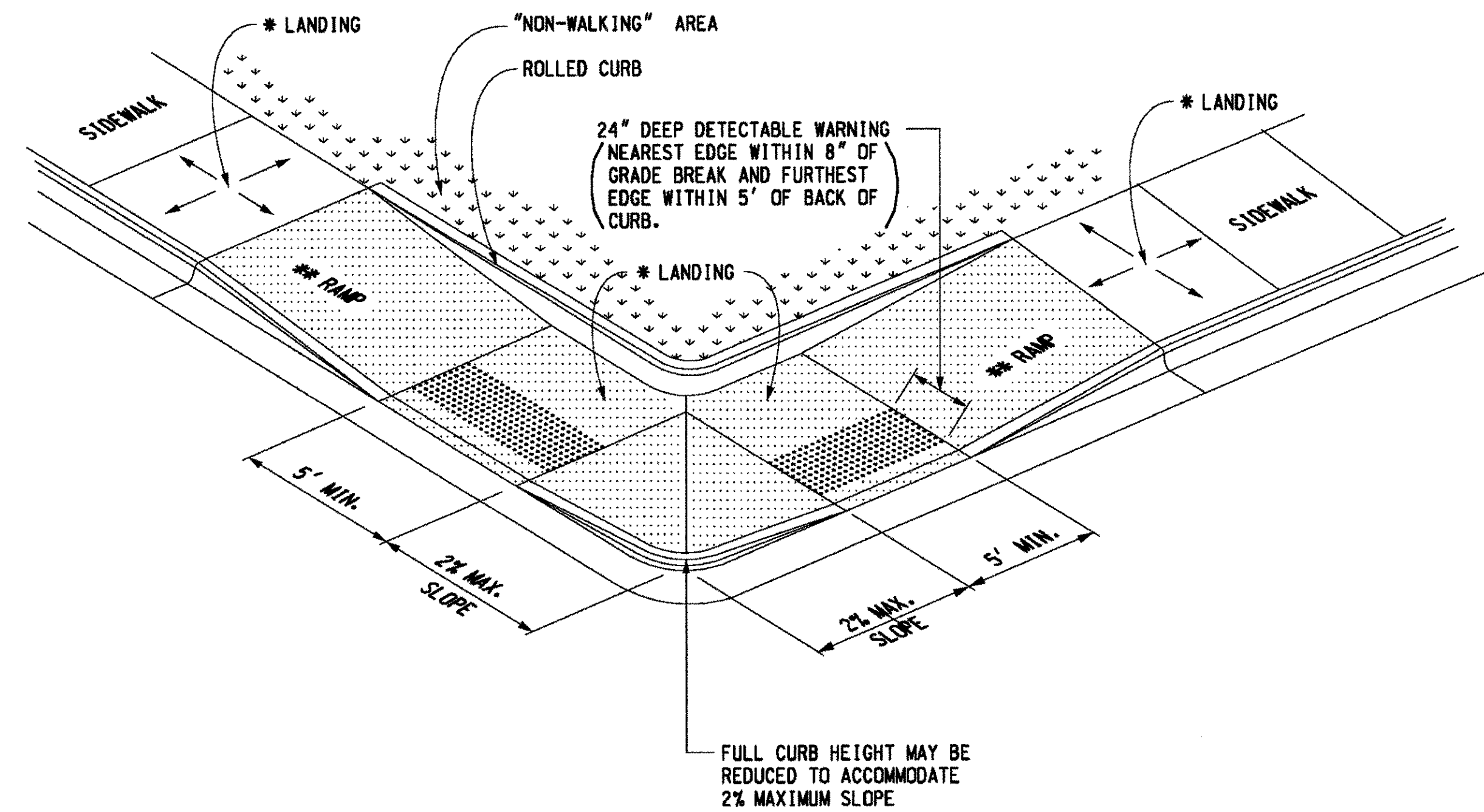

SIDEWALK RAMP TYPE PF

(PARALLEL WITH FLARE)

FULL CURB HEIGHT MAY BE
REDUCED TO ACCOMMODATE
2% MAXIMUM SLOPE

MICHIGAN DEPARTMENT OF TRANSPORTATION
BUREAU OF HIGHWAY DEVELOPMENT STANDARD PLAN FOR

**SIDEWALK RAMP AND
DETECTABLE WARNING DETAILS**

F.H.W.A. APPROVAL	2-19-2008 PLAN DATE	R-28-F	SHEET 4 OF 7
-------------------	------------------------	--------	-----------------

CONTROL SECTION	STU 82400	JOB NO. 86173A	SHEET NO. 57
--------------------	-----------	-------------------	-----------------

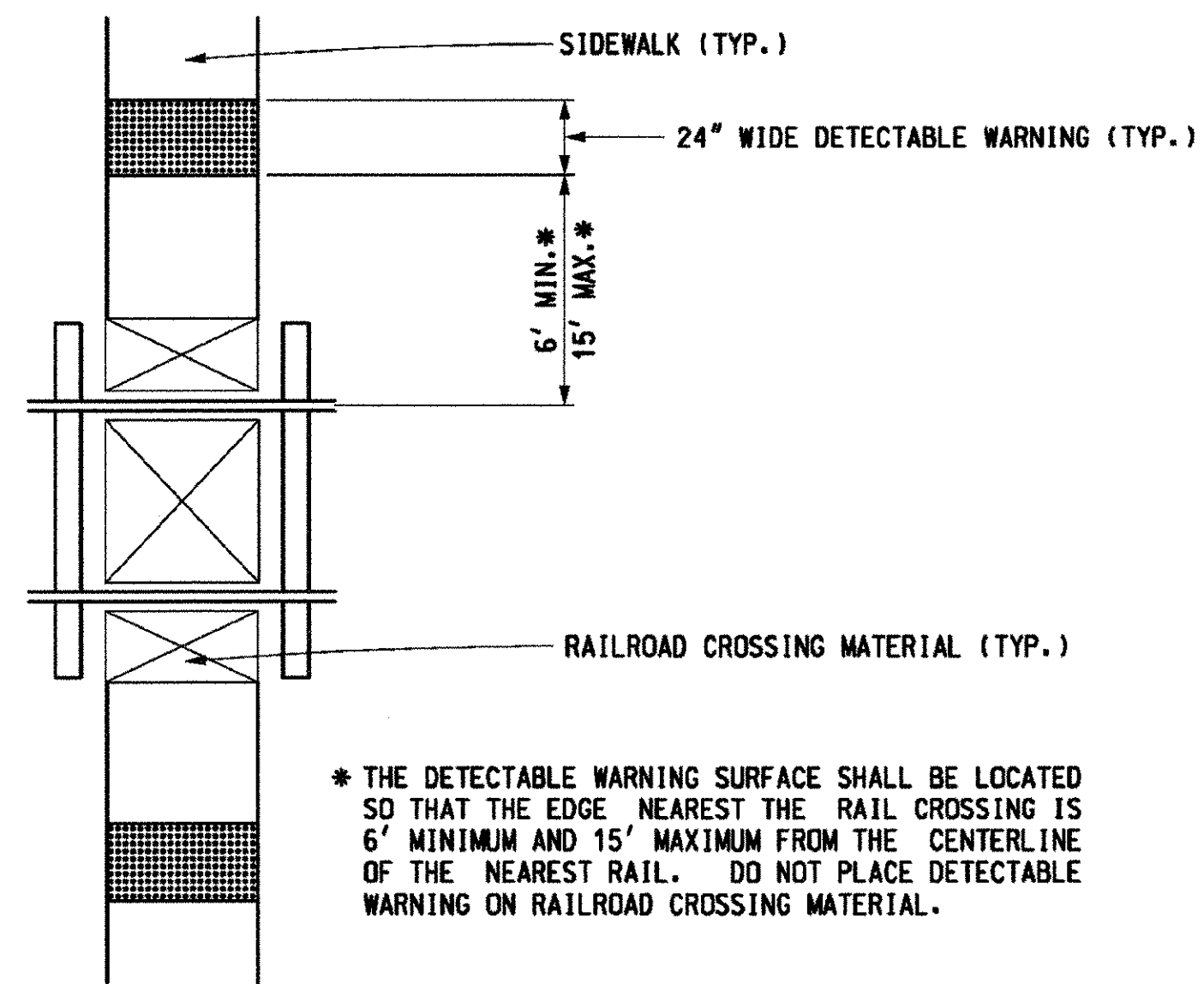

SIDEWALK RAMP TYPE RR
(DETECTABLE WARNING AT RAILROAD CROSSING)

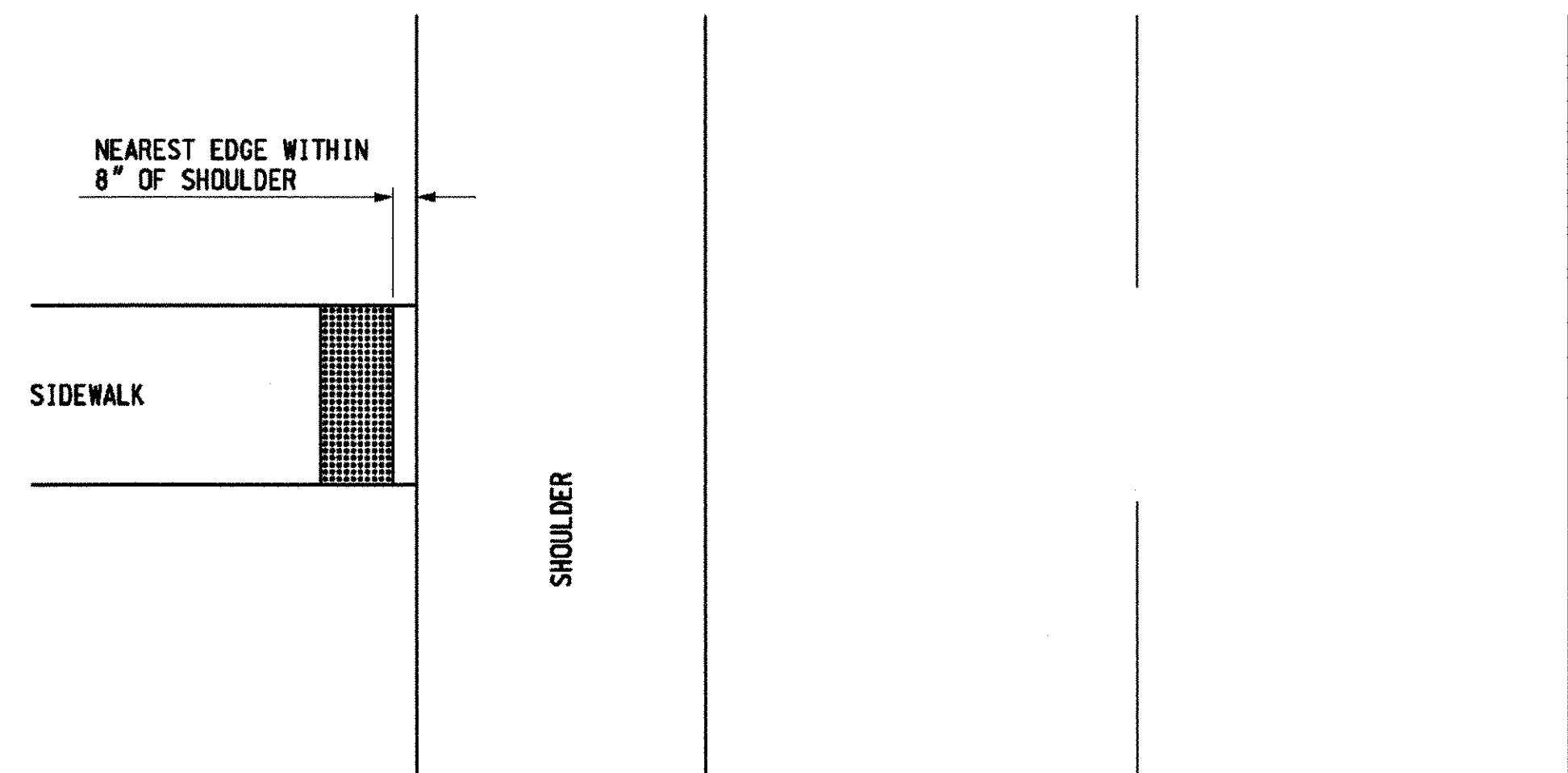

SIDEWALK RAMP TYPE FS
(DETECTABLE WARNING AT FLUSH SHOULDER)

MICHIGAN DEPARTMENT OF TRANSPORTATION
BUREAU OF HIGHWAY DEVELOPMENT STANDARD PLAN FOR

**SIDEWALK RAMP AND
DETECTABLE WARNING DETAILS**

F.H.W.A. APPROVAL	2-19-2008 PLAN DATE	R-28-F	SHEET 5 OF 7
-------------------	------------------------	--------	-----------------

LEGEND

- SIDEWALK RAMP
- "NON-WALKING" AREA
- CROSSWALK MARKING
- PREFERRED LOCATION OF DRAINAGE INLET (TYP.)
- ALTERNATE LOCATION OF DRAINAGE INLET (TYP.)

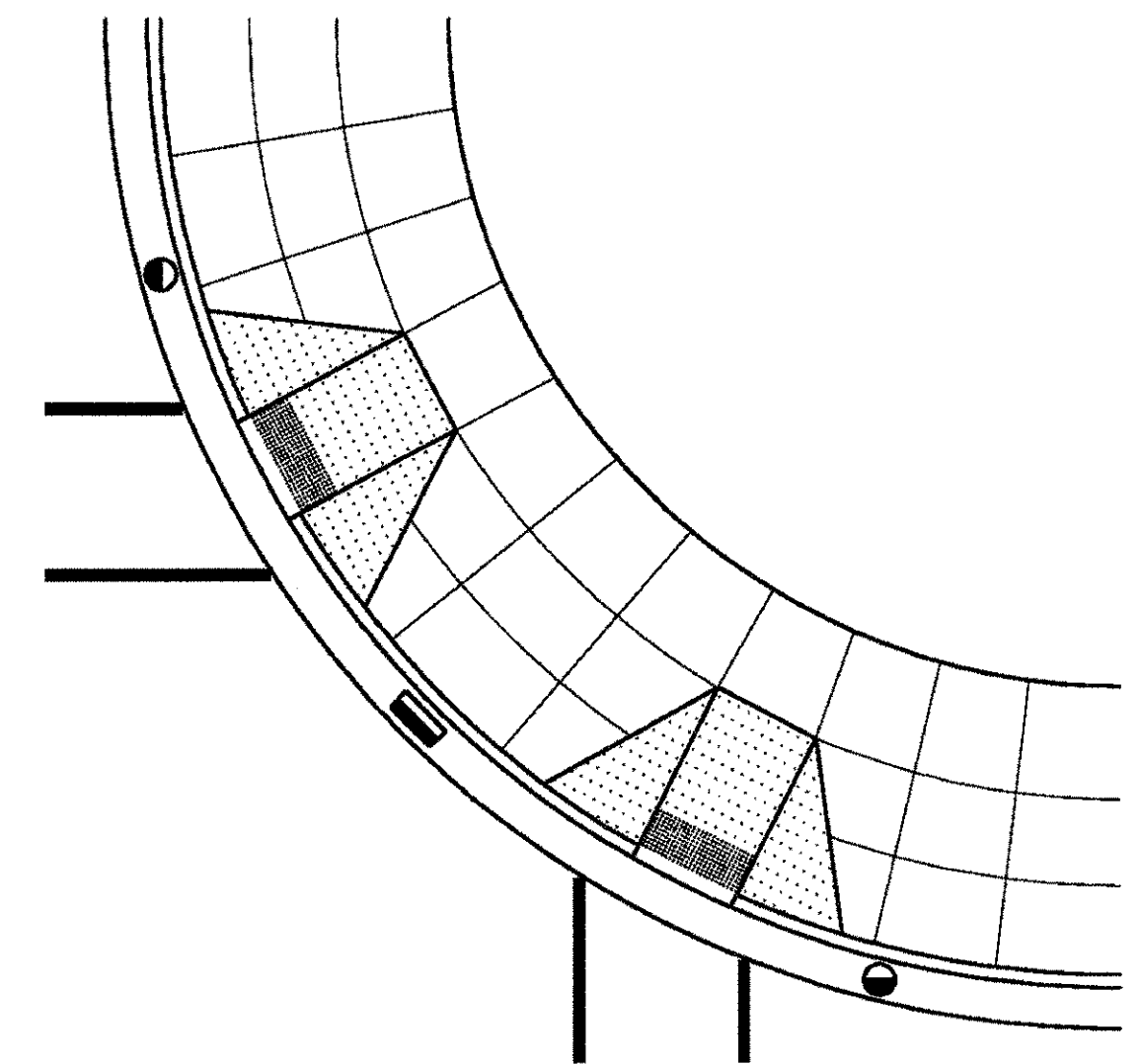

SIDEWALK RAMP PERPENDICULAR TO RADIAL CURB (TYPE F SHOWN)
(USE WITH RADIAL CURB WHEN THE CROSSWALK AND SIDEWALK RAMP ARE NOT ALIGNED)

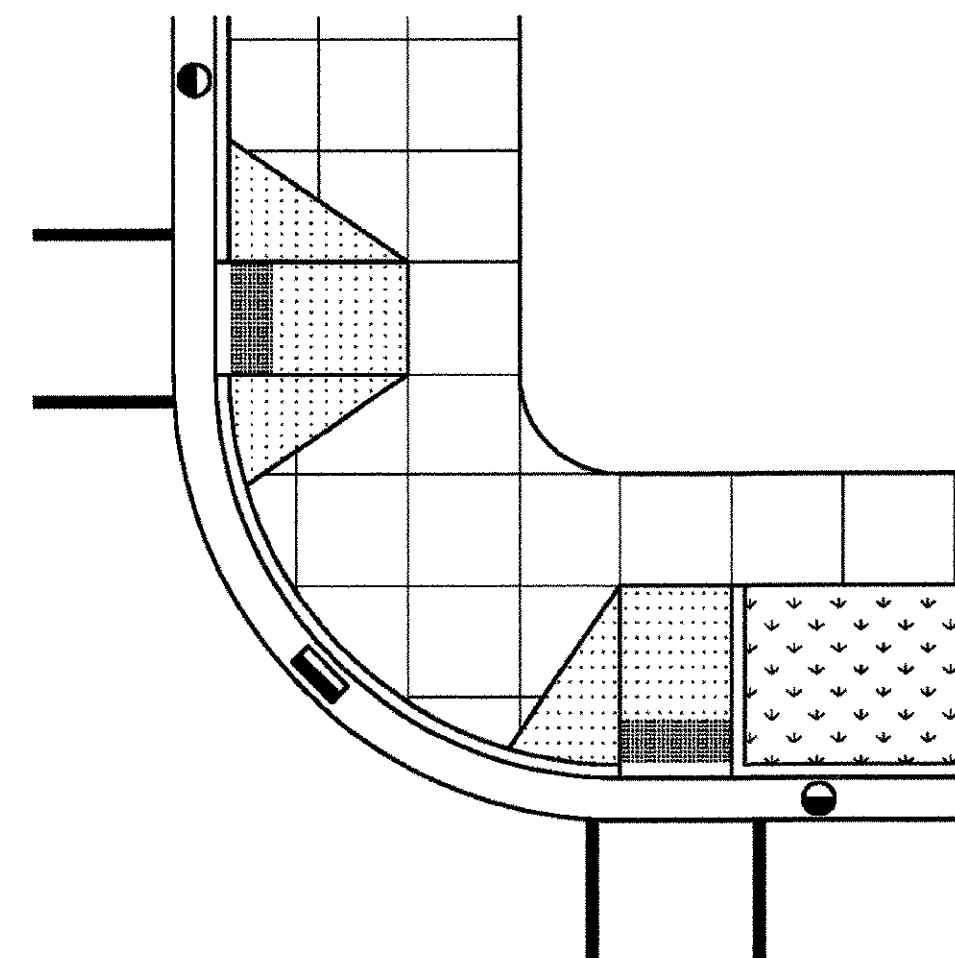

SIDEWALK RAMP PERPENDICULAR TO TANGENT CURB
(TYPE F AND TYPE RF SHOWN)

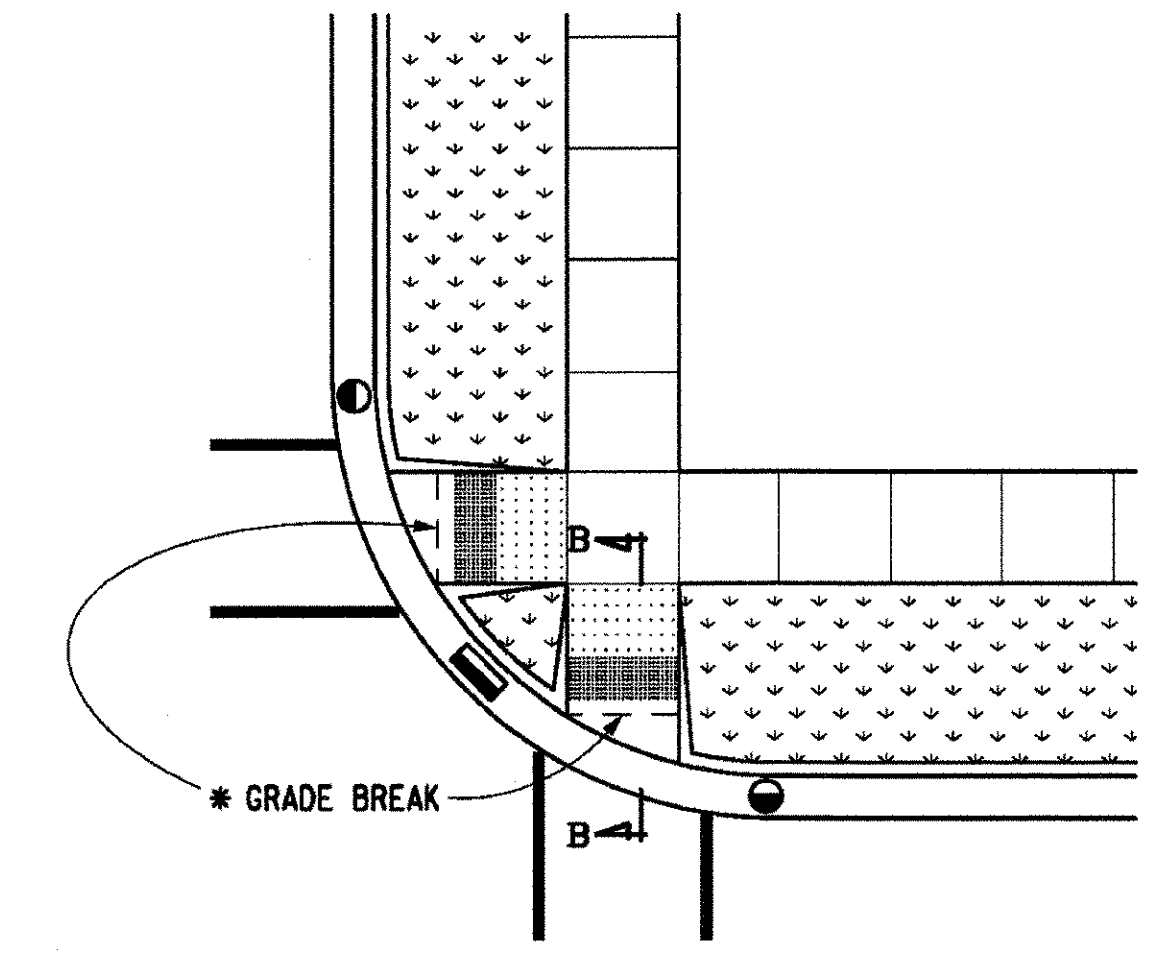

SIDEWALK RAMP LOCATED IN RADIUS, WITH ORIENTATION AS DESCRIBED IN SECTION B-B (TYPE R SHOWN)

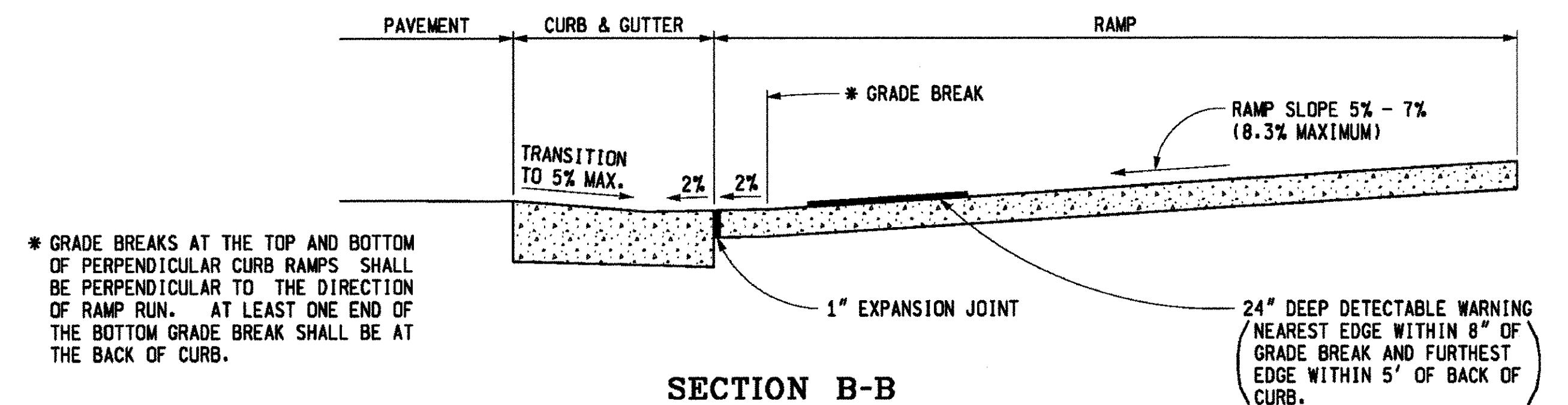

* GRADE BREAKS AT THE TOP AND BOTTOM OF PERPENDICULAR CURB RAMP'S SHALL BE PERPENDICULAR TO THE DIRECTION OF RAMP RUN. AT LEAST ONE END OF THE BOTTOM GRADE BREAK SHALL BE AT THE BACK OF CURB.

SECTION B-B
SIDEWALK RAMP ORIENTATION

MICHIGAN DEPARTMENT OF TRANSPORTATION
BUREAU OF HIGHWAY DEVELOPMENT STANDARD PLAN FOR

**SIDEWALK RAMP AND
DETECTABLE WARNING DETAILS**

F.H.W.A. APPROVAL	2-19-2008 PLAN DATE	R-28-F	SHEET 6 OF 7
-------------------	------------------------	--------	-----------------

CONTROL SECTION STU 82400	JOB NO. 86173A	SHEET NO. 58
---------------------------	----------------	--------------

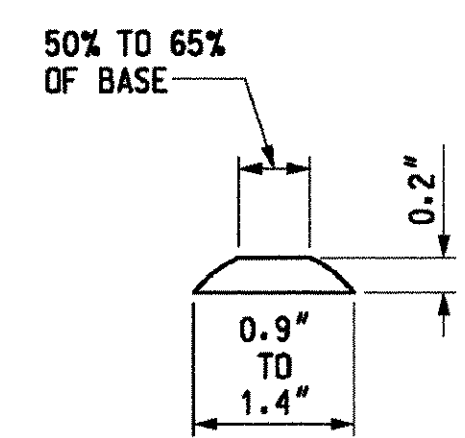

DOME SECTION

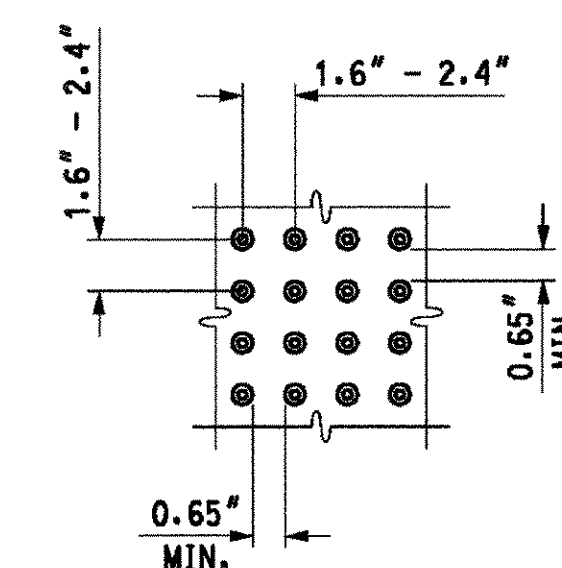

DOME SPACING

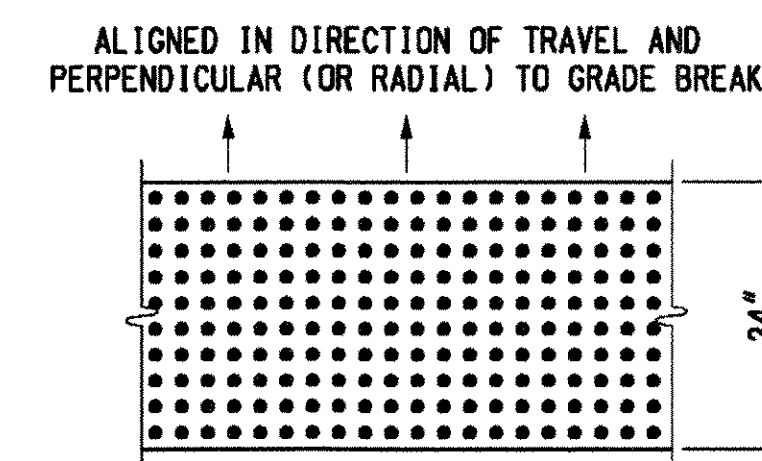

DOME ALIGNMENT

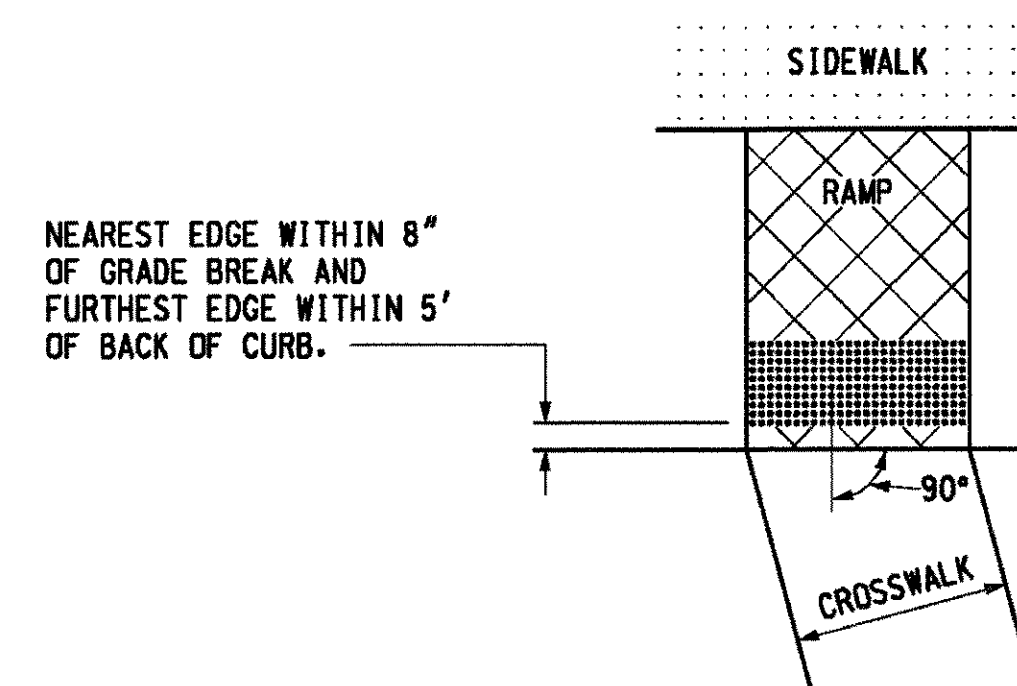

DETECTABLE WARNING DETAILS

NOTES:

DETAILS SPECIFIED ON THIS PLAN APPLY TO ALL CONSTRUCTION, RECONSTRUCTION, OR ALTERATION OF STREETS, CURBS, OR SIDEWALKS BY ALL PUBLIC AGENCIES AND BY ALL PRIVATE ORGANIZATIONS CONSTRUCTING FACILITIES FOR PUBLIC USE.

SIDEWALK RAMPS ARE TO BE LOCATED AS SPECIFIED ON THE PLANS OR AS DIRECTED BY THE ENGINEER.

RAMPS SHALL BE PROVIDED AT ALL CORNERS OF AN INTERSECTION WHERE THERE IS EXISTING OR PROPOSED SIDEWALK AND CURB. RAMPS SHALL ALSO BE PROVIDED AT WALK LOCATIONS IN MID-BLOCK IN THE VICINITIES OF HOSPITALS, MEDICAL CENTERS, AND LARGE ATHLETIC FACILITIES.

SURFACE TEXTURE OF THE RAMP SHALL BE THAT OBTAINED BY A COARSE BROOMING, TRANSVERSE TO THE SLOPE OF RAMP.

SIDEWALK SHALL BE RAMPED WHERE THE DRIVEWAY CURB IS EXTENDED ACROSS THE WALK.

CARE SHALL BE TAKEN TO ASSURE A UNIFORM GRADE ON THE RAMP, FREE OF SAGS AND SHORT GRADE CHANGES. WHERE CONDITIONS PERMIT, IT IS DESIRABLE THAT THE SLOPE OF THE RAMP BE IN ONLY ONE DIRECTION, PARALLEL TO THE DIRECTION OF TRAVEL.

RAMP WIDTH SHALL BE INCREASED, IF NECESSARY, TO ACCOMMODATE SIDEWALK SNOW REMOVAL EQUIPMENT NORMALLY USED BY THE MUNICIPALITY.

IF POSSIBLE, DRAINAGE STRUCTURES SHOULD NOT BE PLACED IN LINE WITH RAMPS. EXCEPT WHERE EXISTING DRAINAGE STRUCTURES ARE BEING UTILIZED IN THE NEW CONSTRUCTION, LOCATION OF THE RAMP SHOULD TAKE PRECEDENCE OVER LOCATION OF DRAINAGE STRUCTURE.

THE SLOPE OF THE GUTTER PAN SHALL BE TRANSITIONED TO A MAXIMUM OF 5% IN THE AREA OF THE CURB CUT OF THE SIDEWALK RAMP. MAINTAIN THE NORMAL GUTTER PAN SLOPE ACROSS THE DRAINAGE STRUCTURE INLETS.

THE TOP OF THE JOINT FILLER FOR ALL RAMP TYPES SHALL BE FLUSH WITH THE ADJACENT CONCRETE.

CROSSWALK AND STOP LINE MARKINGS, IF USED, SHALL BE SO LOCATED AS TO STOP TRAFFIC SHORT OF RAMP CROSSINGS. SPECIFIC DETAILS FOR MARKING APPLICATIONS ARE GIVEN IN THE "MICHIGAN MANUAL OF UNIFORM TRAFFIC CONTROL DEVICES".

DETECTABLE WARNINGS SHALL EXTEND THE FULL WIDTH OF THE CURB RAMP. THEY SHALL BE LOCATED SO THAT THE NEAREST EDGE OF THE DETECTABLE WARNING IS WITHIN 8" OF THE GRADE BREAK AND THE FURTHEST EDGE WITHIN 5' OF THE BACK OF CURB.

FLARED SIDES WITH A SLOPE OF 10% MAXIMUM, MEASURED ALONG THE CURB LINE, SHALL BE PROVIDED WHERE A CIRCULATION PATH CROSSES THE SIDEWALK RAMP. FLARED SIDES ARE NOT REQUIRED WHERE THE EDGES OF A SIDEWALK RAMP ARE PROTECTED BY LANDSCAPING OR OTHER BARRIERS TO TRAVEL BY WHEELCHAIR USERS OR PEDESTRIANS ACROSS THE EDGE OF THE SIDEWALK RAMP.

MICHIGAN DEPARTMENT OF TRANSPORTATION
BUREAU OF HIGHWAY DEVELOPMENT STANDARD PLAN FOR

F.H.W.A. APPROVAL	PLAN DATE		SHEET OF
-------------------	-----------	--	----------

MICHIGAN DEPARTMENT OF TRANSPORTATION
BUREAU OF HIGHWAY DEVELOPMENT STANDARD PLAN FOR

**SIDEWALK RAMP AND
DETECTABLE WARNING DETAILS**

F.H.W.A. APPROVAL	2-19-2008 PLAN DATE	R-28-F	SHEET 7 OF 7
-------------------	------------------------	--------	--------------

CONTROL SECTION	STU 82400	JOB NO.	96173A	SHEET NO.	59
-----------------	-----------	---------	--------	-----------	----

ANCHOR BOLT ASSEMBLY DIMENSIONS								
LIGHT STANDARD MOUNTING HEIGHT	BOLT CIRCLE "A"	ANCHOR BOLT DIA. "B"	"C"	"D"	"E"	STUD PROJECTION "F"	STUD LENGTH "G"	"H"
30'*	11"	1"	11 1/2"	7 3/4"	1 7/8"	4 3/4"	7 1/4"	1'-9 3/4"
30'**	11"	1 1/4"	11 1/2"	7 3/4"	1 7/8"	5 1/2"	8"	1'-10 1/2"
40'**	1'-1"	1 1/4"	1'-2"	9 1/4"	2 3/8"	5 1/2"	8"	1'-10 1/2"
45'**	1'-1"	1 1/4"	1'-2"	9 1/4"	2 3/8"	5 1/2"	8"	1'-10 1/2"

* UP TO 15' SINGLE OR DOUBLE BRACKET ARM
 ** UP TO 17' SINGLE OR DOUBLE BRACKET ARM

ANCHOR BOLTS (4 REQUIRED):
 "B" DIA. x 1'-2" THREADED ROD AND "B" DIA. x "G" STUD
 WITH 4 NUTS, 4 WASHERS, AND ONE COUPLING.

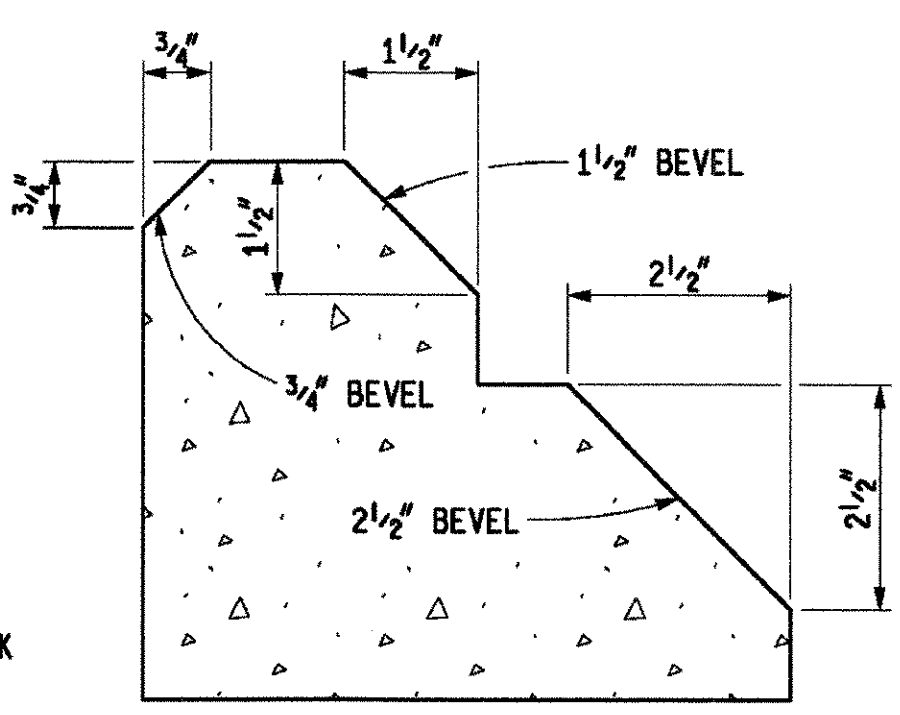
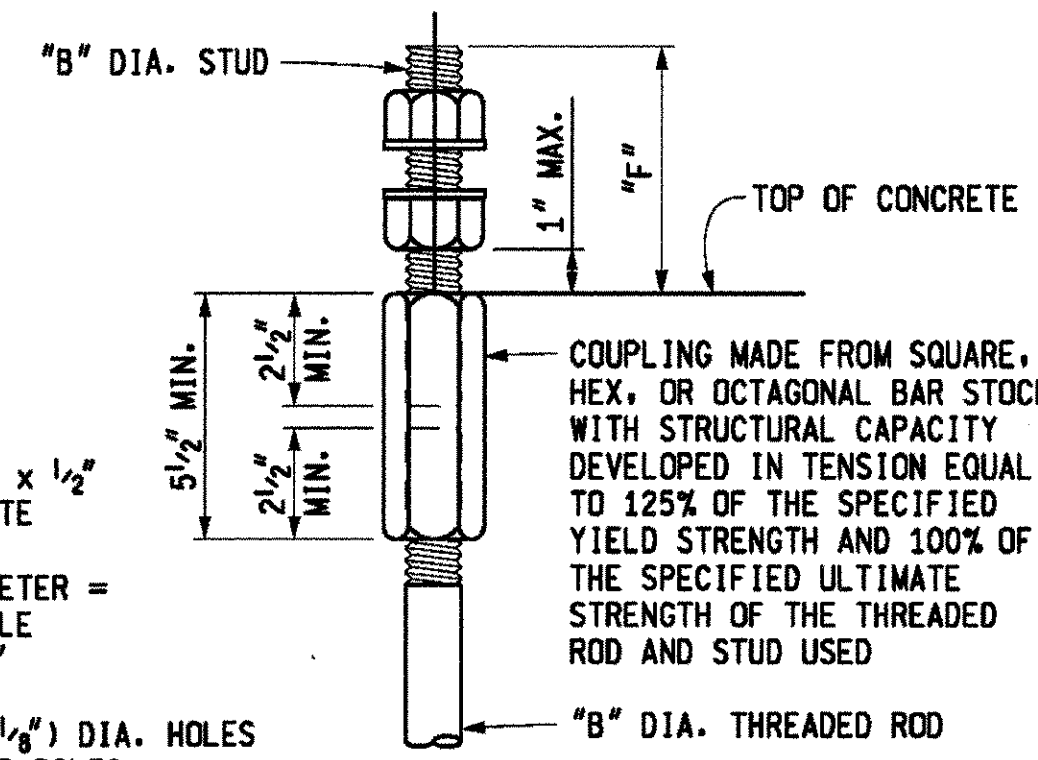
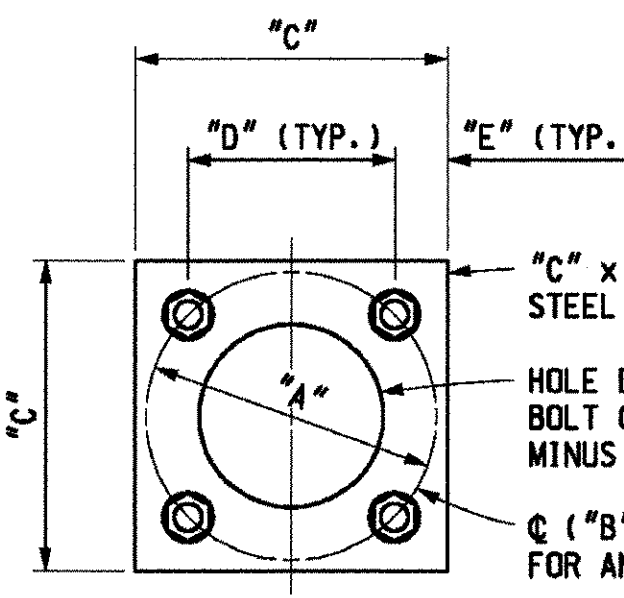
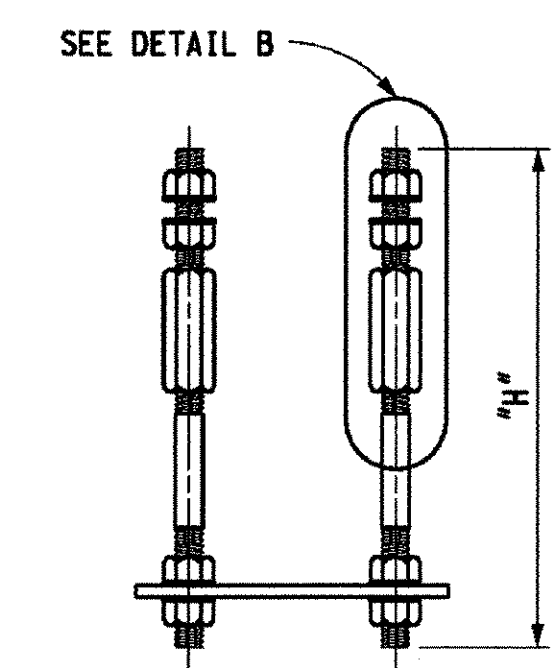

BEVEL DETAILS

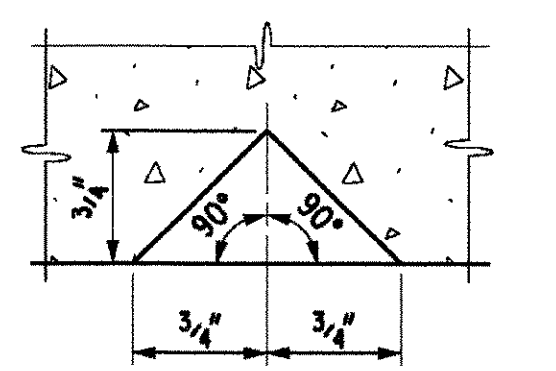

DOUBLE 3/4" Δ MOLDING

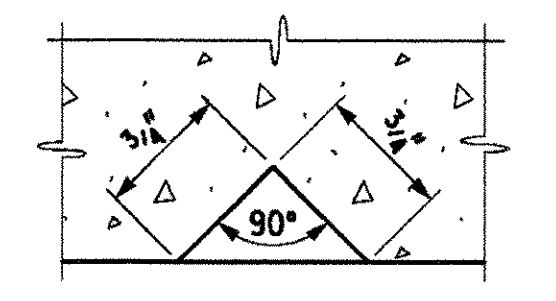

3/4" Δ MOLDING
 MOLDING DETAILS

DETAIL B
 LIGHT STANDARD ANCHOR BOLT ASSEMBLY

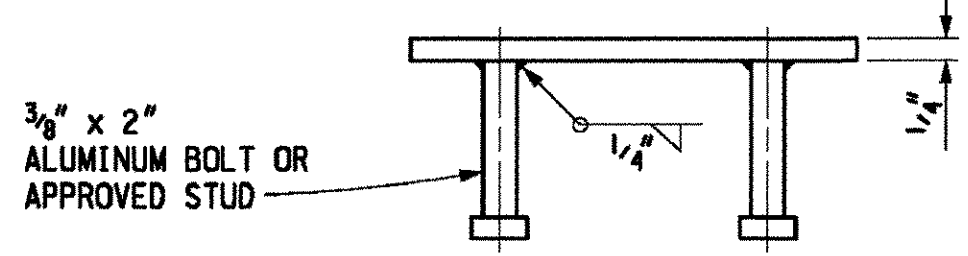
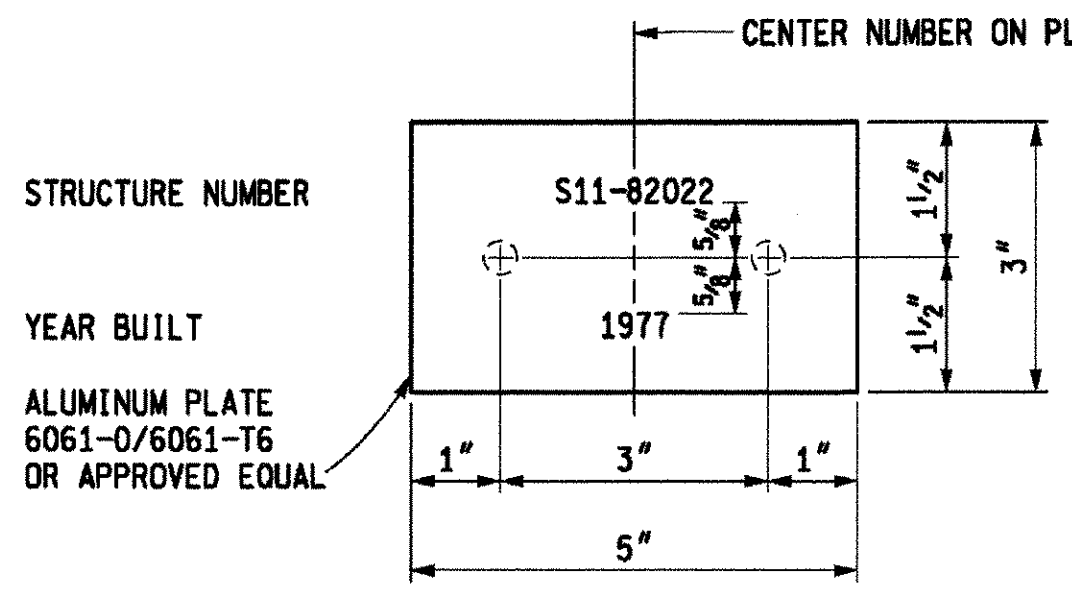

NAME PLATE

NOTES:
 DIE STAMP - 1/4" MINIMUM
 LETTERS AND NUMBERS SHALL BE 1/4" MINIMUM OR 3/8" MAXIMUM HEIGHT.
 DATE SHALL BE YEAR THAT SUPERSTRUCTURE WAS COMPLETED.

NOTES:
 DETAILS SHOWN ARE ACCORDING TO THE CURRENT AASHTO SPECIFICATIONS.
 LIGHT STANDARD ANCHOR BOLT ASSEMBLY STEEL PLATE SHALL BE ASTM A36.
 ALL STEEL SHALL BE HOT-DIP GALVANIZED ACCORDING TO THE CURRENT STANDARD SPECIFICATIONS.
 ANCHOR BOLTS, WASHERS, COUPLINGS AND NUTS FOR LIGHT STANDARDS SHALL BE ACCORDING TO THE CURRENT STANDARD SPECIFICATIONS.
 THE COUPLING SHALL BE RETAPPED AFTER GALVANIZING IN THE SAME MANNER AS SPECIFIED FOR NUTS.
 ALUMINUM PLATE SHALL MEET THE REQUIREMENTS OF ASTM B209.
 ALUMINUM BOLT SHALL MEET THE REQUIREMENTS OF ASTM F468.

	DEPARTMENT DIRECTOR Kirk T. Steudle	MICHIGAN DEPARTMENT OF TRANSPORTATION BUREAU OF HIGHWAY DEVELOPMENT STANDARD PLAN FOR	
	PREPARED BY DESIGN DIVISION DRAWN BY: B.L.T. CHECKED BY: V.Z.	APPROVED BY: _____ ENGINEER OF DELIVERY	MOLDING, BEVEL, LIGHT STD. ANCHOR BOLT ASSY., AND NAME PLATE DETAILS
	APPROVED BY: _____ ENGINEER OF DEVELOPMENT	3-30-2007 PLAN DATE	B-103-E
		F.H.W.A. APPROVAL	SHEET 1 OF 1
		CONTROL SECTION STU 82400	JOB NO. 86173A SHEET NO. 60