

TRAFFIC DATA
 POSTED SPEED 35 MPH
 DESIGN SPEED 45 MPH
 PRESENT ADT (1991) 5795
 FUTURE ADT (2010) 11705
 DESIGN LOADING HS20 &
 ALTERNATE MILITARY LOADING

PLAN INDEX	
SH. NO.	DESCRIPTION
1	TITLE SHEET
2	SUMMARY OF QUANTITIES
3	MAINTENANCE OF TRAFFIC
4-5	DRAINAGE PLAN
6-7	STRIPING AND SIGNING
8-9	GENERAL PLAN OF STRUCTURE
10	PROFILE GRADE
11	SPAN 1 - REMOVAL
11A	SPAN 16 - REMOVAL
12-13	ABUTMENT A - REMOVAL
14-15	ABUTMENT B - REMOVAL
16	GENERAL PLAN - SOUTH APPROACH
17	GENERAL PLAN - NORTH APPROACH
18-19	RETAINING WALLS STA 12+59 TO 16+51
20	RETAINING WALLS STA. 33+00 TO 34+50
21	NORTH/SOUTH APPROACH - DETAILS
22-24	STRUCTURAL STEEL DETAILS
25	BEARING DETAILS
26-27	DRAINAGE DETAILS
28	EXPANSION JOINT DETAILS
29	ABUTMENT A - FOOTING DETAILS
30	ABUTMENT A - WALL DETAILS
31	ABUTMENT B - FOOTING DETAILS
32	ABUTMENT B - WALL DETAILS
33-44	SUPERSTRUCTURE DETAILS
45-48	REINFORCEMENT BAR LIST
49-51	LIGHTING DETAILS
52-53	PEDESTRIAN FENCING DETAILS
54-57	SUBSTRUCTURE REPAIRS
57A	DRY FIRE PROTECTION LINE

MDOT STANDARD PLANS

Where the following items are called for on the plans they are to be constructed according to the standard plan given below opposite each item unless otherwise indicated.

- II-300 CONCRETE CURB AND CONCRETE CURB & GUTTER
- II-39K TRANSVERSE PAVEMENT JOINTS
- II-44G CONCRETE PAVEMENT REPAIR
- II-45E CONVENTIONAL PAVEMENT REINFORCEMENT
- II-45G CONVENTIONAL PAVEMENT REINFORCEMENT (WIRE FABRIC)
- III-67D GUARDRAIL ANCHORAGE - BRIDGE, DETAILS
- XI-101B DRAIN CASTING ASSEMBLY DETAILS

THESE STANDARD PLANS WILL NOT BE PRINTED.

CITY OF DETROIT
 IN CO-OPERATION WITH
MICHIGAN DEPARTMENT OF TRANSPORTATION
 AND
FEDERAL HIGHWAY ADMINISTRATION

PLANS OF PROPOSED BRIDGE REHABILITATION
 FEDERAL BRIDGE REPLACEMENT PROJECT NO. BHN 9482(050)
 MICHIGAN CRITICAL BRIDGE PROJECT NO. MSC 82022
 MOUNT ELLIOTT MOUND ROAD OVER GTWRR

WAYNE CO.
 CITY OF DETROIT
 PART 1 AND 2

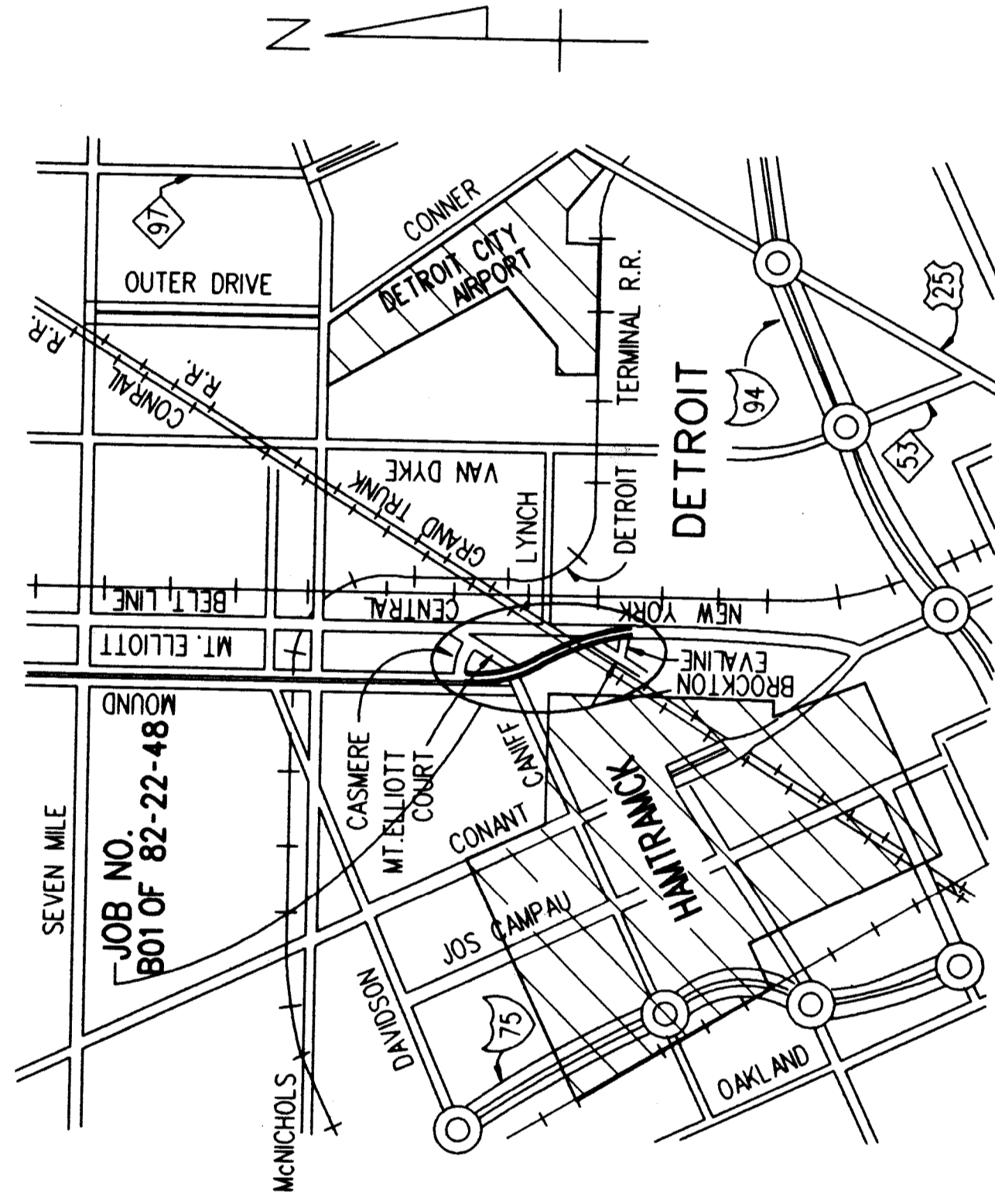

CITY OF DETROIT STANDARD PLANS

Where the following items are called for on the plans they are to be constructed according to the standard plan given below opposite each item unless otherwise indicated.

- 101-PLD MISC. ENCASED CONDUIT SECTION DETAILS
- 101A-PLD DETAIL FOR JOINING CONDUIT ENCASUREMENTS
- 114-PLD MULT. ST. LTG. CABLE CONNECTIONS, CLAMP-ON ARM & MISC. DETAILS
- 115-PLD CODE 009-00 ST. LTG. STD. DETAILS

THESE STANDARD PLANS PROVIDED IN SET.

GENERAL NOTES

The design of this structure, rehabilitation is based on current AASHTO Standard Specifications for Highway Bridges HS20 and alternate military loading. Live load plus impact deflection does not exceed 1/1000 of span length and 1/375 of cantilever arm. The load factor method of design was used for this structure.

Except where otherwise indicated on these plans, or in the proposal and supplemental specifications contained herein, all materials and workmanship shall be in accordance with the Michigan Department of Transportation Standard Specifications for Construction 1990 edition.

Public Lighting Department work to be done in accordance with P.L.D. Specifications and City of Detroit Division 15 Standards.

The stationing as shown on these plans is believed to be correct. It shall, however, be checked at the time of starting construction, and if the stationing shown on the plans is incorrect, it shall be reported to the Engineering office in Detroit, and the structure shall be staked out using the actual centerline as the control point.

All exposed concrete corners shown square on the plans shall be beveled with 1/2" triangular moldings except as otherwise noted.

The design of the structural members is based on material of the following grades and stresses:

Concrete:	Grade 35S	f'c =	3,000psi
Concrete:	Grade 45D	f'c =	4,000psi
Steel Reinforcement:	A36	fy =	60,000psi
Structural Steel:	A442 modified	fy =	36,000psi
Grade 50		fy =	50,000psi

UTILITIES

- DETROIT EDISON 1-800-477-4747
- MICHIGAN CONSOLIDATED GAS CO. 313-965-8080
- AMERITECH 313-221-6100
- DETROIT WATER & SEWER DEPARTMENT 313-267-7401
- MISSDIG 1-800-482-7171
- CITY OF DETROIT, PUBLIC LIGHTING DEPARTMENT 313-267-7306

CONTRACT FOR REHABILITATION OF MOUNT ELLIOTT-MOUND ROAD GRADE SEPARATION

LOCAL AUTHORITY APPROVAL
 CITY OF DETROIT
 DEPARTMENT OF PUBLIC WORKS

APPROVED BY *William J. Kelly* 7/1/94
 WILLIAM J. KELLY, P.E. DATE
 APPROVED BY *Clayton D. Howell* JUL 13 1994
 CLAYTON D. HOWELL DATE

PREPARED UNDER SUPERVISION OF

ROBERT ALICE P.E. REGISTERED PROFESSIONAL ENGINEER
 BAKER AND ASSOCIATES & WALTER TEAMER
 AND ASSOCIATES, INC. A JOINT ASSOCIATION
 ORGANIZATION
 118 SOUTH CLINTON ST.
 CHICAGO, ILLINOIS

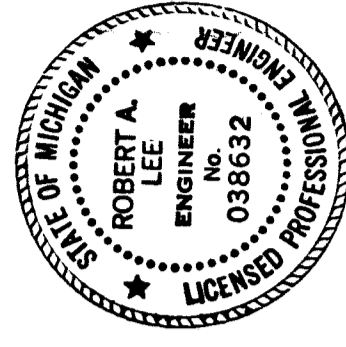

Robert A. Lee
 June 30, 1994

CONTROL SECTION	JOB NUMBER	PROJECT	DATE

SUMMARY OF QUANTITIES

WORK-ITEM CODE	DESCRIPTION	QUANTITY	UNITS
5030010	CONCRETE GRADE 355-SUBFOOTING	38	CYD
5030018	EPOXY MORTAR OR CONCRETE FOR PATCHING	100	CFT
5030023	SUBSTRUCTURE CONCRETE	394	CYD
5030024	SUPERSTRUCTURE CONCRETE	1723	CYD
5030030	STEEL REINFORCEMENT	36,088	LBS
5030031	STEEL REINFORCEMENT, EPOXY COATED	370,524	LBS
5030099	EXPANSION JOINT DEVICE	1,033	LFT
5030052	PENETRATING WATER REPELLENT TREATMENT	419	SYD
5080024	BRIDGE BARRIER RAILING, TYPE 5	162	LFT
5087002	BRIDGE BARRIER RAILING, TYPE 5(MOD) FOR RAILING REPLACEMENT	4,203	LFT
5087004	CONCRETE MEDIAN BARRIER (SP)	2,050	LFT
5090001	SCARIFYING	10,446	SYD
5090070	REMOVAL OF PORTION OF STRUCTURES (REHABILITATION)	1	LSUM
5090075	FALSE DECKING	4600	SYD
5090076	HYDRODEMOLISHING-FIRST PASS	10,466	SYD
5090077	HYDRODEMOLISHING-SECOND PASS	485	SYD
2090003	UNCLASSIFIED FOUNDATION EXCAVATION	531	CYD
5060001	JOINT WATERPROOFING	108	SFT
6230001	MOBILIZATION	1	LSUM
5030181	EXPANSION-ANCHORED BOLTS, 3/4"	98	EACH
5090030	EPOXY ANCHORING OF VERTICAL BAR, 1/2"	530	EACH
5090031	EPOXY ANCHORING OF VERTICAL BAR, 5/8"	1,467	EACH
5030310	CONSTRUCTING BRIDGE DECK SURFACE	9925	SYD
5030027	FORMING, FINISHING, AND CURING SUPERSTRUCTURE CONCRETE	1	LSUM
2070009	REMOVING BEAM GUARDRAIL	256	LFT
5090099	REPAIRING STRUCTURAL CRACKS	150	LFT
6210110	PEDESTRIAN FENCING-STRUCTURES	22,111	SFT
6290350	OVERLAY COLD PLASTIC PAVEMENT MARKING, 4" WHITE	4,323	LFT
6290351	OVERLAY COLD PLASTIC PAVEMENT MARKING, 4" YELLOW	4,600	LFT
6290361	OVERLAY COLD PLASTIC PAVEMENT MARKING, 24", STOP BAR	33	LFT
6290366	OVERLAY COLD PLASTIC PAVEMENT MARKING, RIGHT TURN ONLY	2	EACH
6290376	OVERLAY COLD PLASTIC PAVEMENT MARKING, RIGHT TURN ARROW SYMBOL	2	EACH
5140013	SEWER CLEAN OUT	2,150	LFT
5140014	CLEANING DRAINAGE STRUCTURE	15	EACH
5030200	BRIDGE END HEADER	108	LFT

Wick

SUMMARY OF QUANTITIES

WORK-ITEM CODE	DESCRIPTION	QUANTITY	UNITS
4520011	CONCRETE PAVEMENT REPAIR-REINFORCED 9"	454	SYD
5030140	DRAIN CASTING, TYPE 1	58	EACH
5100005	HANGER ASSEMBLY REMOVAL AND ERECTION	11	EACH
5100001	STRUCTURAL STEEL, FURNISHING AND FABRICATING	2,300	LBS
5040085	BUSHING	22	EACH
5100003	FIELD MEASUREMENT OF HANGER ASSEMBLY	11	EACH
5100016	TEMPORARY SUPPORT, SUSPENSION TYPE	11	EACH
5040002	STRUCTURAL STEEL FABRICATION AND ERECTION (PLATES)	200	LBS
5040045	CLEANING EXISTING STEEL STRUCTURE (TYPE 4)	1	LSUM
5040046	COATING EXISTING STEEL STRUCTURE (TYPE 4)	1	LSUM
5030131	LIGHT STANDARD ANCHOR ASSEMBLY, FURNISHED AND PLACED	23	EACH
5030171	CONDUIT, 3"	4365	LFT
6310054	MINOR TRAFFIC DEVICES	1	LSUM
6310057	SIGN, TYPE B TEMPORARY	189	SFT
6310025	BARRICADE, TYPE II	7	EACH
6310036	BARRICADE, TYPE III	8	EACH
6020122	FOUNDATION UNDERDRAIN, 8"	250	LFT
4000010	CHIPPING CONCRETE PAVEMENT FOR JOINTS	377	SYD
4000100	BITUMINOUS MIXTURE NO. 1500L, 20AAA	708	TON
4000006	BITUMINOUS PRIME COAT	429	GAL
2080021	EMBANKMENT (CIP)	1444	CYD
5010001	PERMANENT SHEET PILING	1488	SFT
5090007	HAND CHIPPING-OTHER THAN DECK	100	CFT
4500296	EXPANSION-ANCHORED LANE-TIES	272	EACH
6210004	TEMPORARY FENCE	1331	LFT
5090017	FORMING FOR PATCHES	300	SFT
6900090	JUNCTION BOX IN BARRIER WALL	23	EACH
6900612	250W HIGH PRESSURE SODIUM LUMINAIRE	24	EACH
6907002	REFURBISH EXISTING POLE	24	EACH
6910486	2 KV., 2-1/C #6 STREET LIGHTING CABLES & 1- #6 NEUTRAL	14100	LFT
4000020	REPAIRING PAVEMENT JOINTS AND CRACKS, DETAIL 7	1092	LFT

APPROXIMATELY 1500 T WEAVING COURSE ?

Wick Dressing

Wick Dressing

MICHIGAN DEPARTMENT OF TRANSPORTATION
 MOUNT ELLIOTT-MOUND ROAD BRIDGE
 IN THE CITY OF DETROIT
SUMMARY OF QUANTITIES

DESIGN SUPERVISING ENGINEER

APPROVED

NO. _____ DESCRIPTION _____ DATE _____ BY _____

REVISIONS

SOUD BOSS NAME RAL DATE 1/94
 DRAWN BY NAME RBC
 CHECKED BY NAME RAD DATE 1/94
 SHEET 2 OF 54

B01 of 82-22-48

CURVE DATA C3

PI STA 24+61.17
 Δ 54°15'00"
 D 8°00'
 R 716.20'
 L 678.12'
 T 366.89'
 E 88.51'

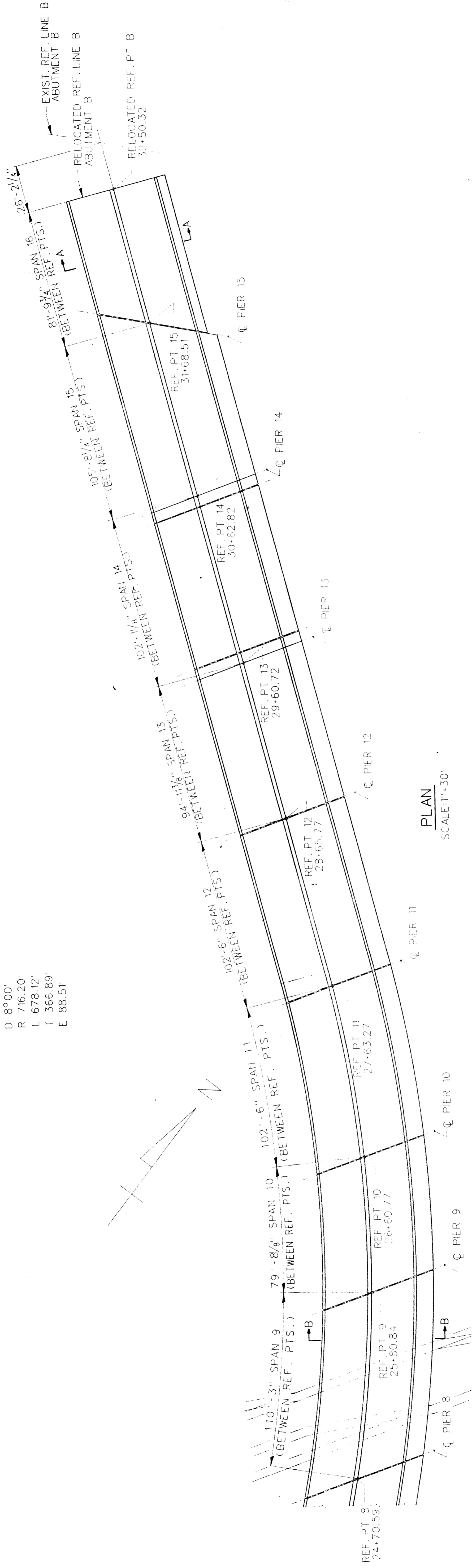

PLAN
 SCALE: 1"=30'

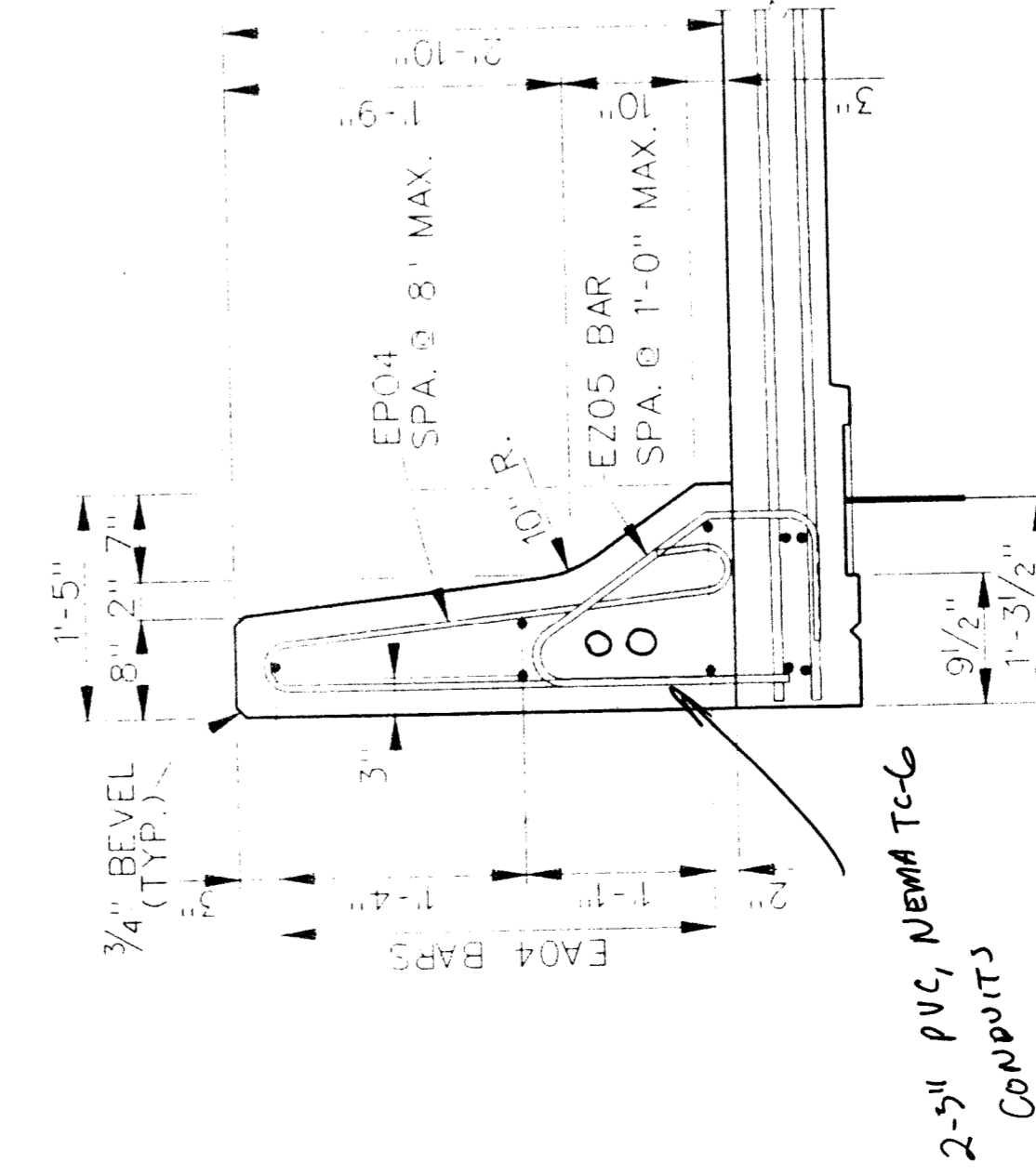

TYPICAL BARRIER SECTION

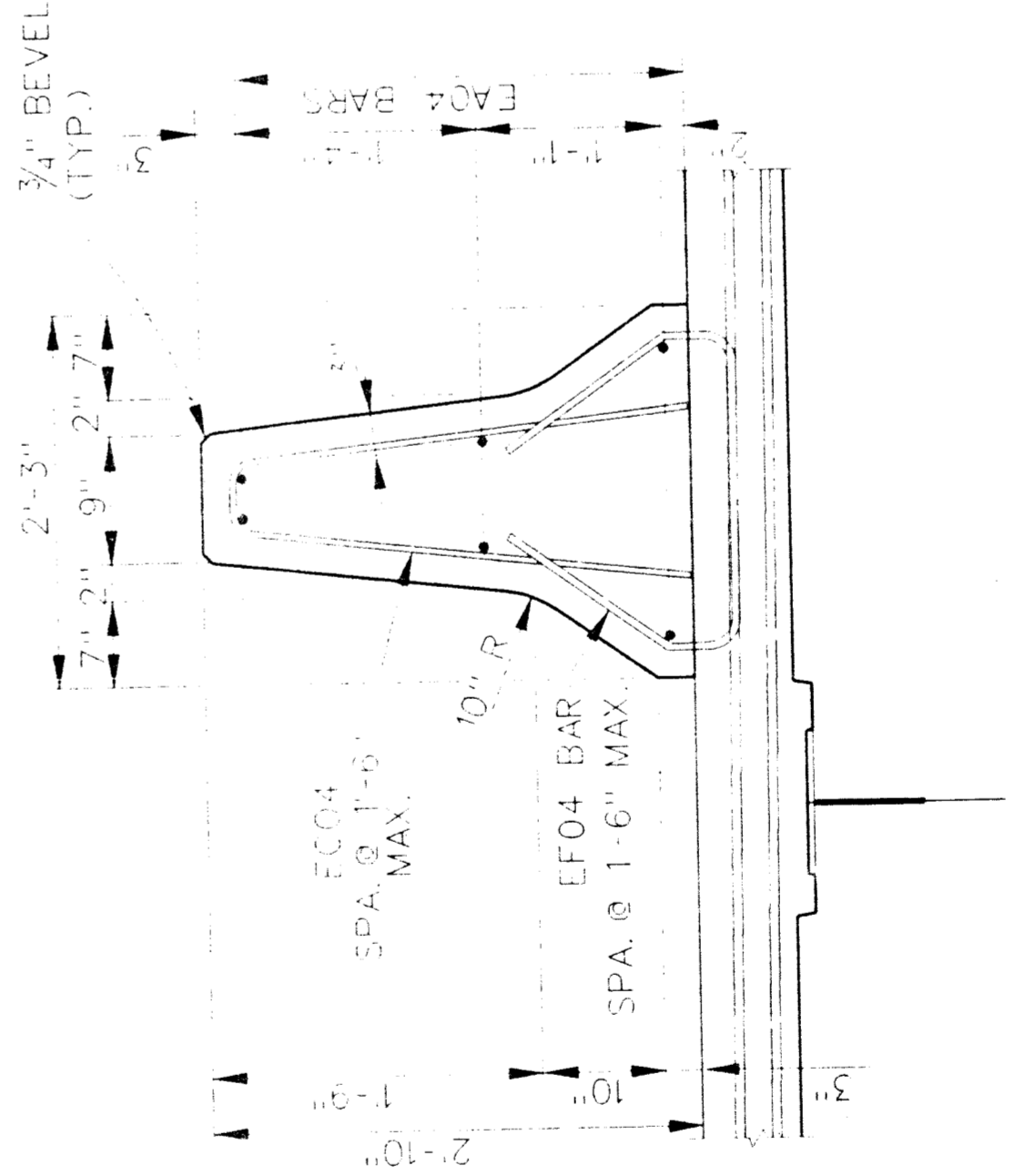

TYPICAL MEDIAN BARRIER SECTION

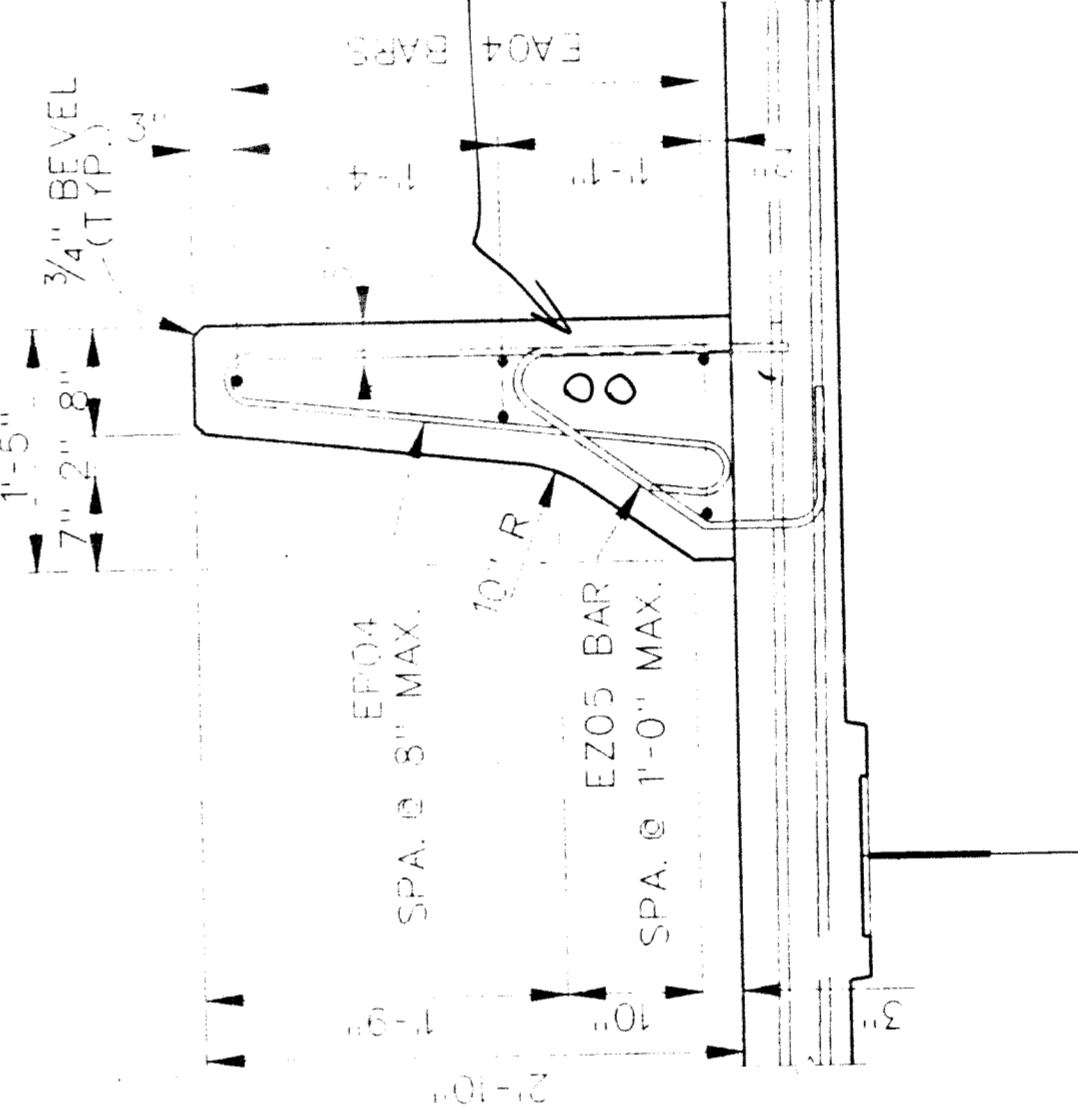

TYPICAL BARRIER SECTION
 AT SIDEWALK

NOTES:
 FOR SECTIONS A-A AND B-B, SEE SHEET 2 OF 4.
 FOR SECTION AT DECK JOINTS, SEE SHEET 4 OF 4.
 FOR ABUTMENT B LAYOUT, SEE SHEET 4 OF 4.

MICHIGAN DEPARTMENT OF TRANSPORTATION
 MOUNT ELLIOTT-MOUND ROAD BRIDGE
 IN THE CITY OF DETROIT
 GENERAL PLAN OF STRUCTURE

DESIGNER	NAME	DATE
DRAWN BY	NAME	DATE
CHECKED BY	NAME	DATE
SHEET	9	OF 54

B01 of 82-22-48

NO.	REVISION	DATE	BY

APPROVED
 DESIGN SUPERVISING ENGINEER

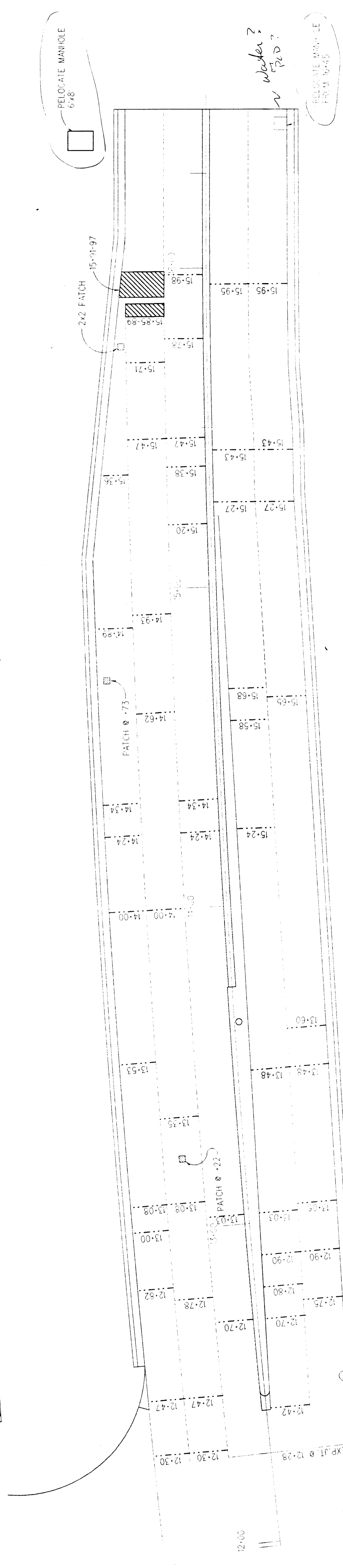

EXISTING PLAN

OR
 --- OR --- DENOTES AREAS IN NEED OF SLAB REPLACEMENT DUE TO CRACKS IN PAVEMENT.
 X --- LIGHT POLE

SEE DRAWING NO. 82-22-48 FOR BRIDGE TO BE RELOCATED TO BRIDGE

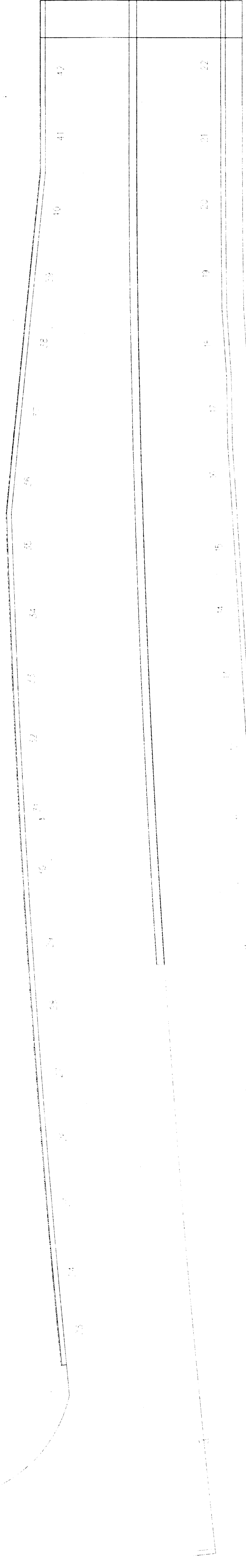

PROPOSED PLAN



BAKER AND ASSOCIATES
 WALTER TEAMER AND ASSOCIATES, INC.
 A JOINT ASSOCIATION
 18431 JAMES COUZENS DETROIT, MI 48235

MICHIGAN DEPARTMENT OF TRANSPORTATION
 MOUNT ELLIOTT-MOUND ROAD BRIDGE
 IN THE CITY OF DETROIT
 GENERAL PLAN SOUTH APPROACH

DESIGNED BY	NAME	DATE
CHECKED BY	NAME	DATE
APPROVED	NAME	DATE

DESIGN SUPERVISING ENGINEER

B01 of 82-22-48

NO.	DESCRIPTION	DATE	BY

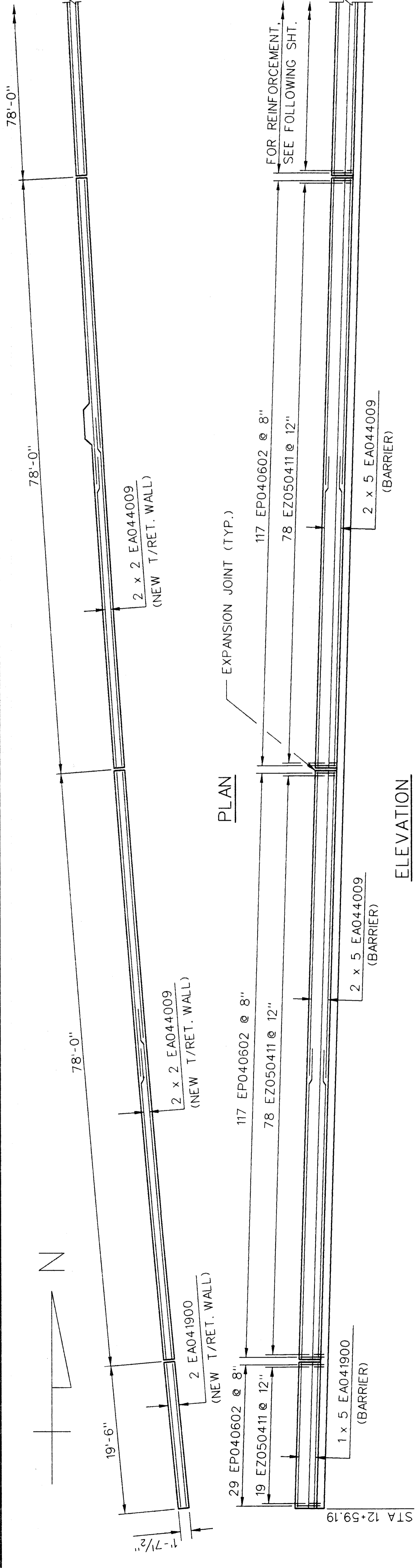

ELEVATION

RETAINING WALLS - S. APPROACH - WEST WALL

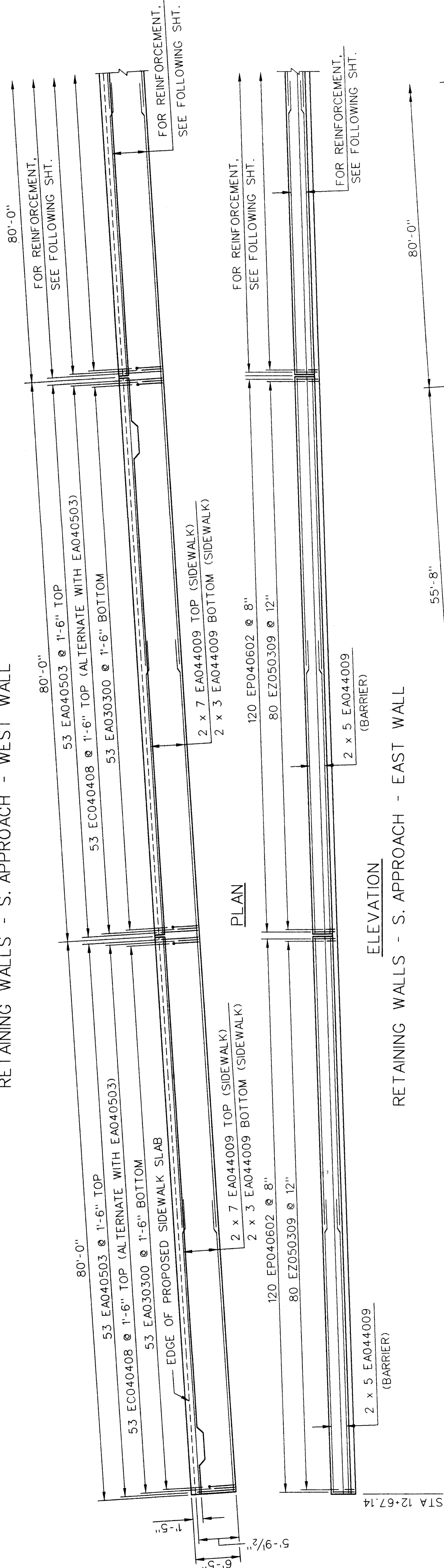

PLAN

ELEVATION

RETAINING WALLS - S. APPROACH - EAST WALL

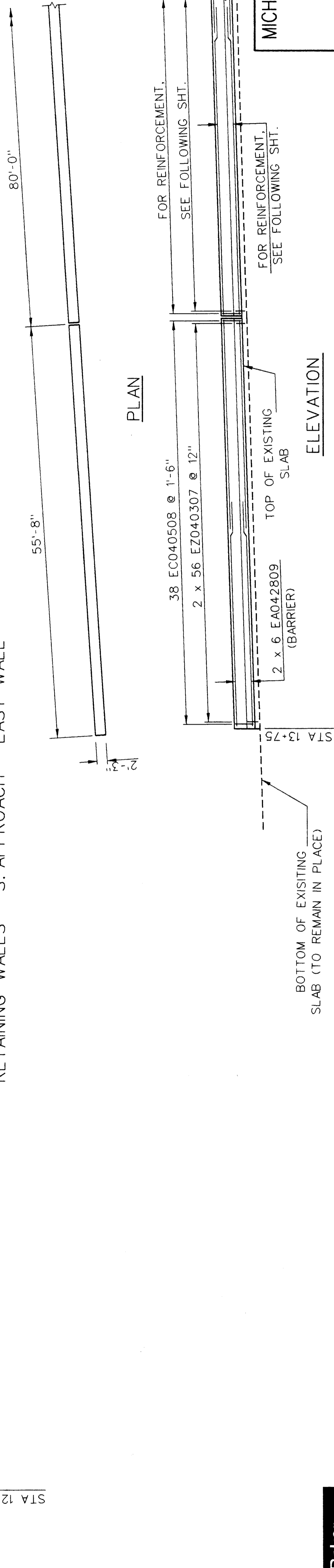

PLAN

ELEVATION

RETAINING WALLS - S. APPROACH - MEDIAN WALL

NO.	DESCRIPTION	REVISIONS	DATE	BY

Baker
WTA
 BAKER AND ASSOCIATES
 WALTER TEAMER AND ASSOCIATES, INC.
 A JOINT ASSOCIATION
 18431 JAMES COUZENS DETROIT, MI 48235

MICHIGAN DEPARTMENT OF TRANSPORTATION
 MOUNT ELLIOTT-MOUND ROAD BRIDGE
 IN THE CITY OF DETROIT
RETAINING WALLS
 STA. 12+59 TO 16+51
 B01 of 82-22-48

DESIGN SUPERVISING ENGINEER
 APPROVED

GROUP	NAME	DATE
GROUP BOSS	NAME	DATE 11/93
DRAWN BY	NAME	DATE 11/93
CHECKED BY	NAME	DATE 11/93
SHEET	NO.	OF 54

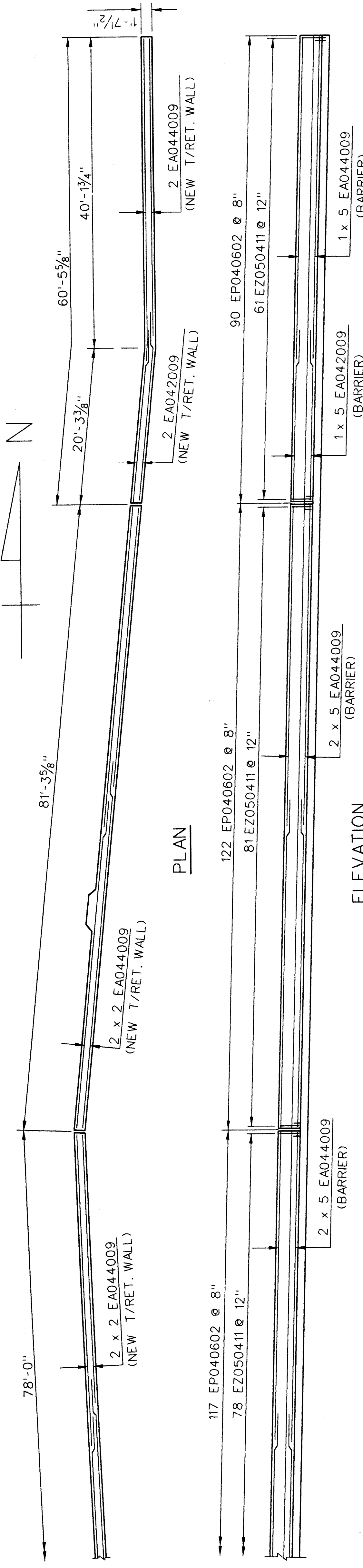

RETAINING WALLS - S. APPROACH - WEST WALL

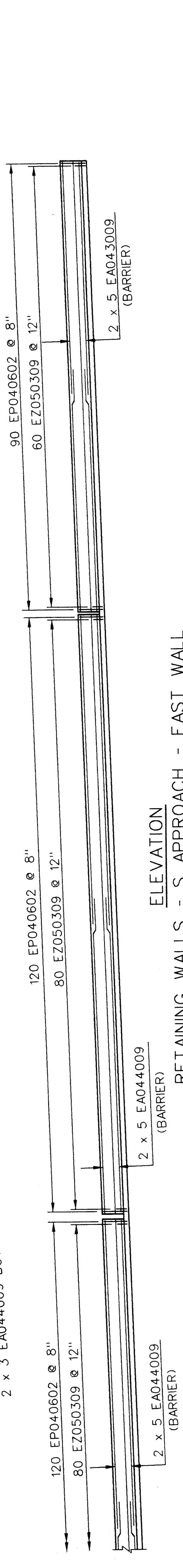
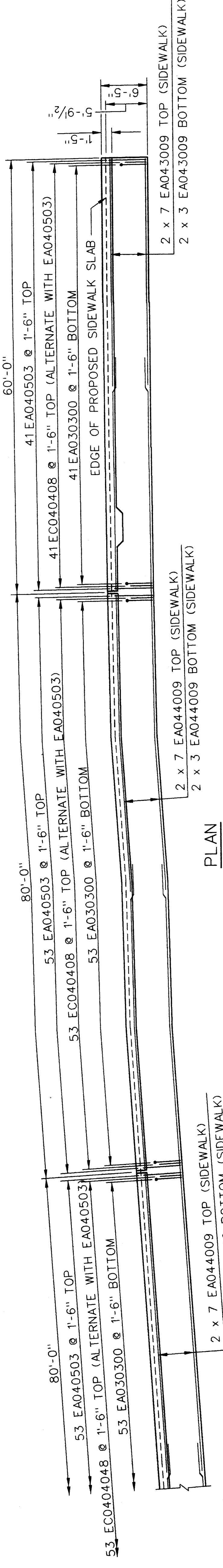

RETAINING WALLS - S. APPROACH - EAST WALL

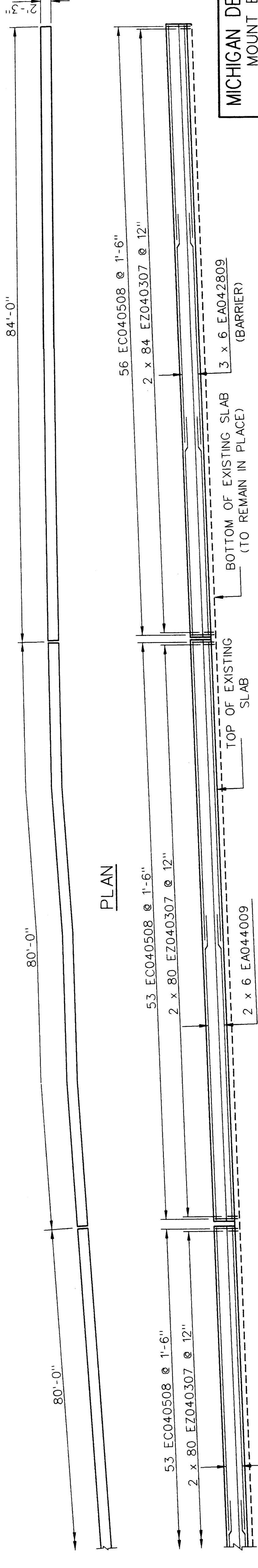

RETAINING WALLS - S. APPROACH - MEDIAN WALL

Baker
WTA
 BAKER AND ASSOCIATES
 WALTER TEAMER AND ASSOCIATES, INC.
 A JOINT ASSOCIATION
 18431 JAMES COUZENS DETROIT, MI 48235

MICHIGAN DEPARTMENT OF TRANSPORTATION
 MOUNT ELLIOTT-MOUND ROAD BRIDGE
 IN THE CITY OF DETROIT
 RETAINING WALLS
 STA. 12+59 TO 16+51

DESIGNED BY	NAME	DATE
CHECKED BY	NAME	DATE
DRAWN BY	NAME	DATE
SCALE	DATE	DATE

APPROVED
 DESIGN SUPERVISING ENGINEER

B01 of 82-22-48

NO.	DESCRIPTION	REVISIONS	DATE	BY

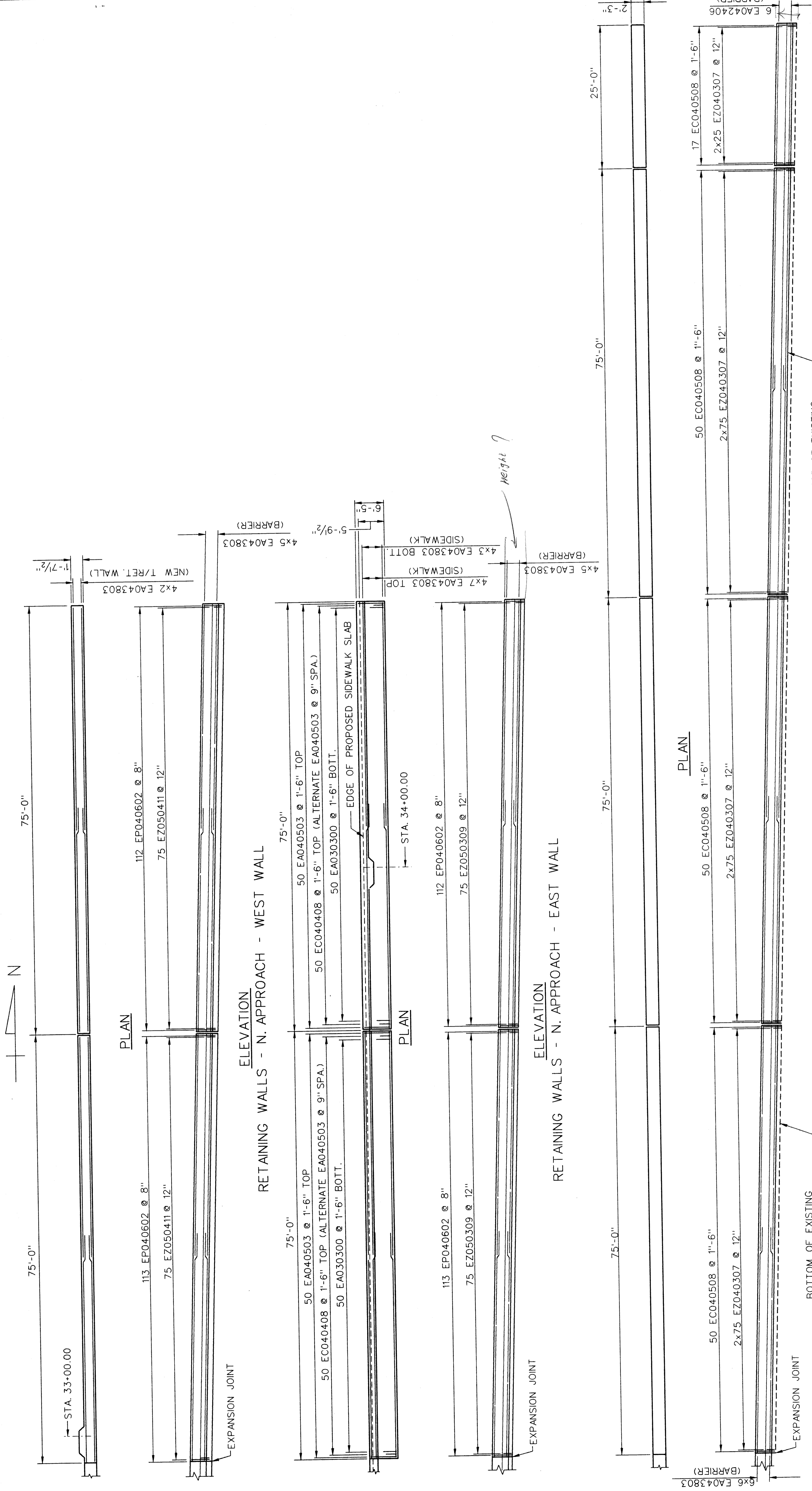

NO.	DESCRIPTION	DATE	BY

MICHIGAN DEPARTMENT OF TRANSPORTATION
 MOUNT ELLIOTT-MOUND ROAD BRIDGE
 IN THE CITY OF DETROIT
RETAINING WALLS
 STA. 33+00 TO 34+50

DESIGN SUPERVISING ENGINEER
 APPROVED

DATE	11/93
NAME	WTA
BY	WTA
DATE	11/94
NAME	WTA
BY	WTA
DATE	11/94
NAME	WTA
BY	WTA
DATE	11/94
NAME	WTA
BY	WTA

SHEET 19 OF 54
B01 of 82-22-48

Baker
WTA

BAKER AND ASSOCIATES
 WALTER TEAMER AND ASSOCIATES, INC.
 A JOINT ASSOCIATION
 18431 JAMES COUZENS DETROIT, MI 48235

NOTES:
 POUR SLAB AGAINST EXISTING PAVEMENT
 CUT EXISTING VERTICAL BARS 2" BELOW FINAL SLAB ELEVATION
 3/4" BEVEL ALL EXTERIOR EDGES
 ALL REINFORCING 2" CLEAR
 THE 1/2" ASPHALT OVERLAY SHALL NOT BE APPLIED TO THE SIDEWALK.
 EZ04 BARS IN MEDIAN AND EZ05 BARS IN EAST BARRIER TO BE EPOXY ANCHORED.
 THE TYPICAL WEST, TYPICAL MEDIAN, AND TYPICAL EAST (& SIDEWALK) BARRIER SECTIONS ARE APPLICABLE TO BOTH THE NORTH AND SOUTH ABUTMENTS.

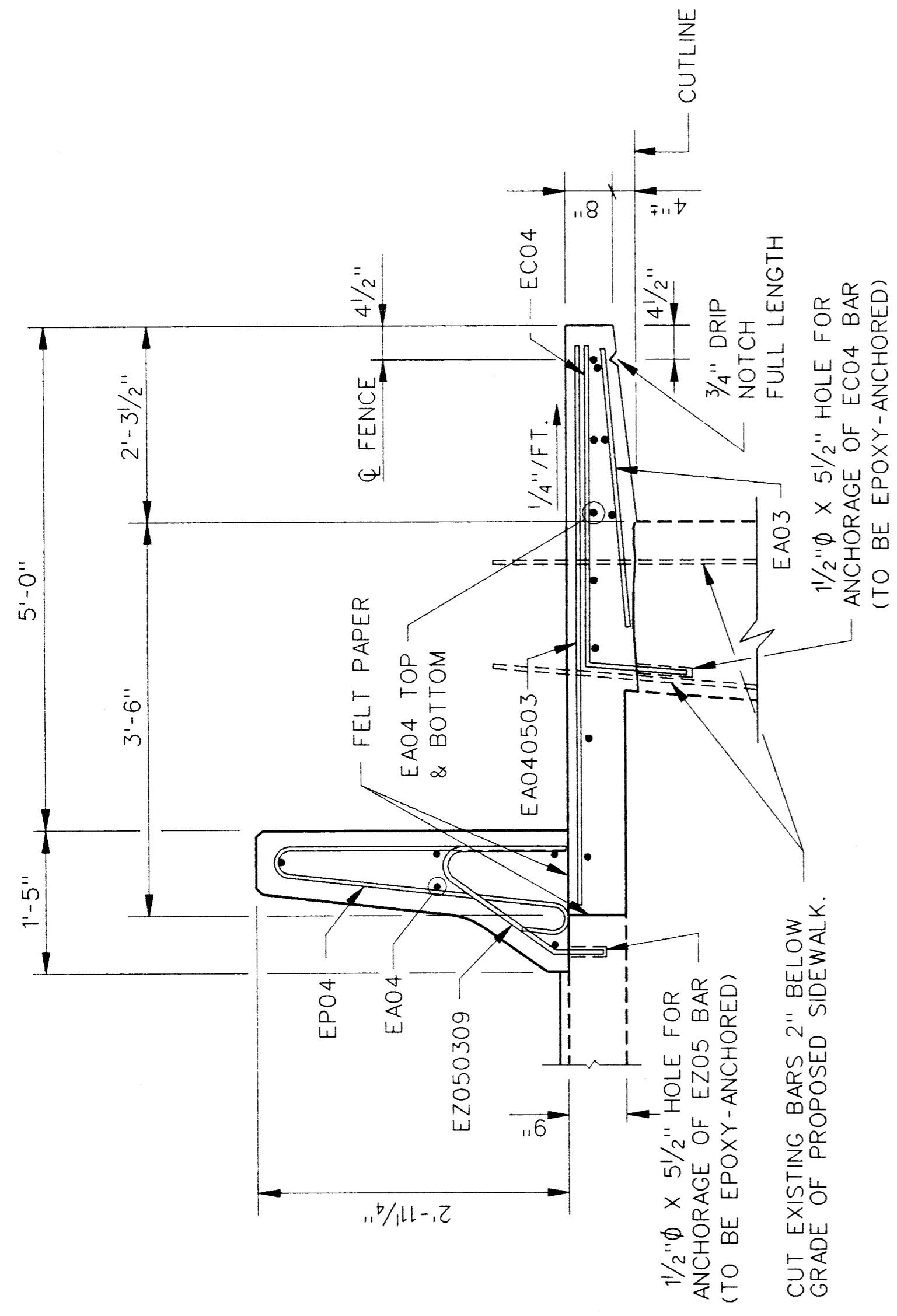

TYPICAL EAST BARRIER & SIDEWALK

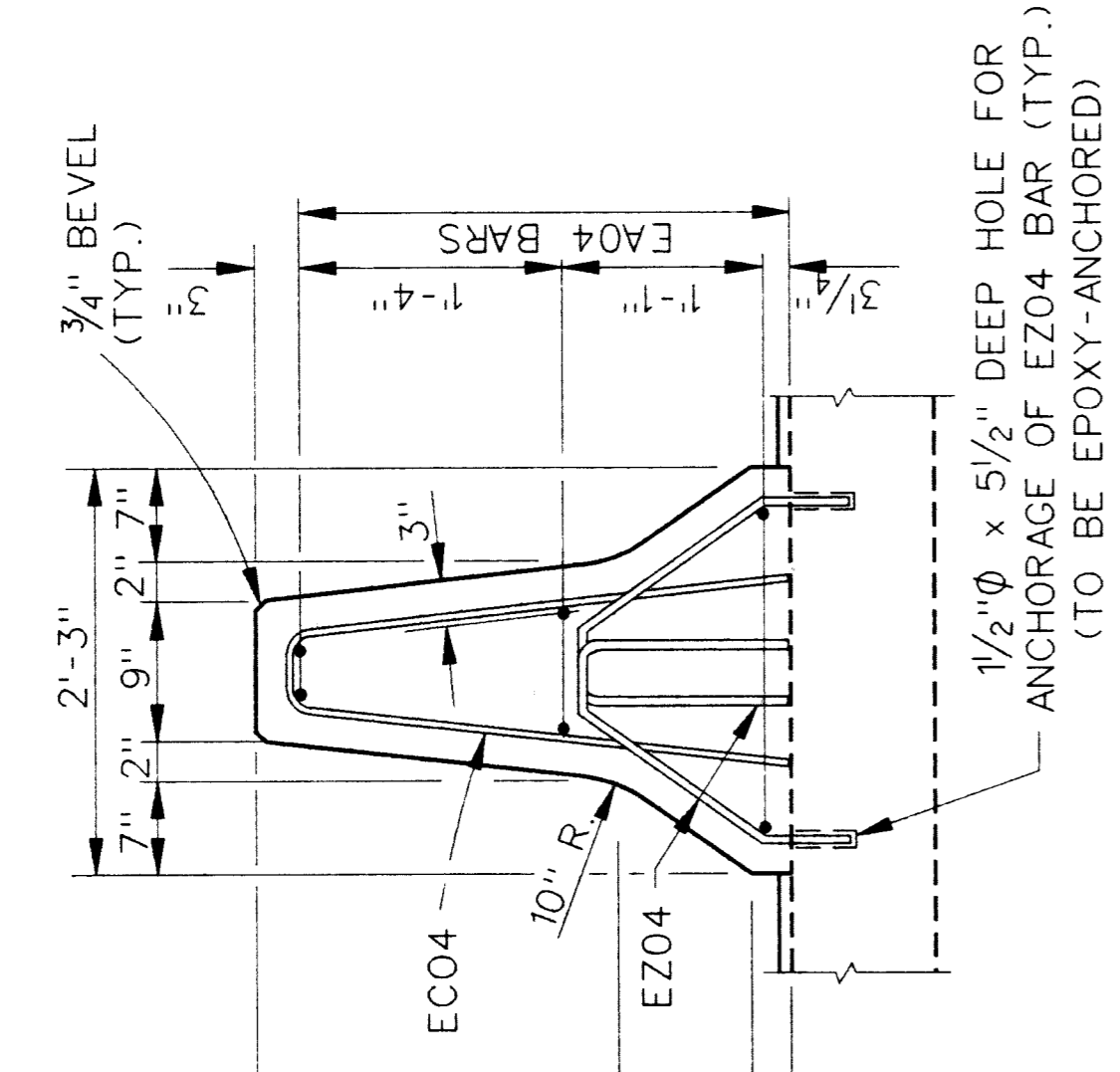

TYPICAL MEDIAN BARRIER SECTION ALONG APPROACHES

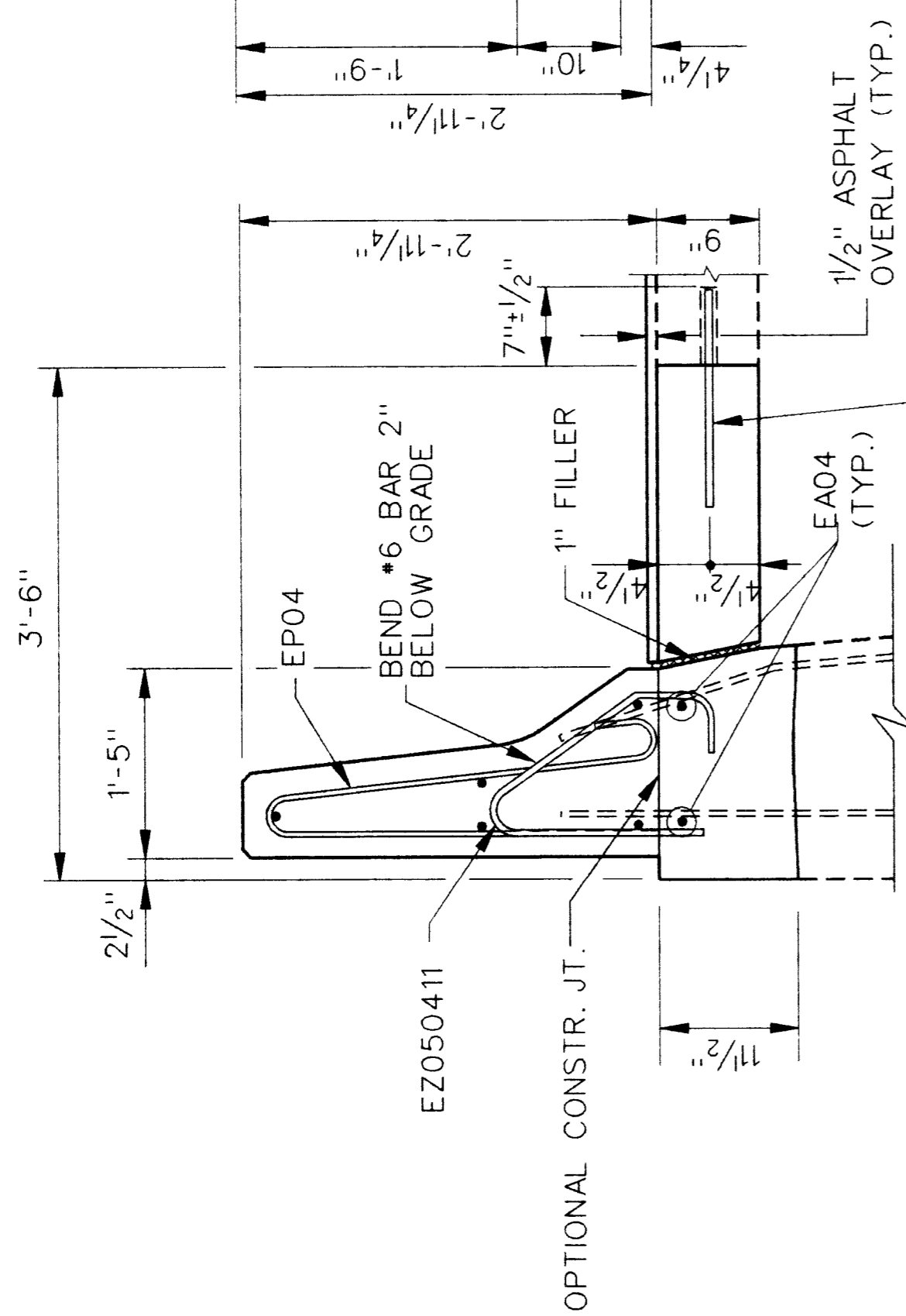

TYPICAL WEST BARRIER

DRILL 3/4" Ø HOLE INTO EXISTING PAVEMENT AND GROUT-IN-PLACE #5 x 1'-6" LONG EPOXY-COATED DEFORMED BAR. (BILLED WITH MISC. QUANT. BELOW)

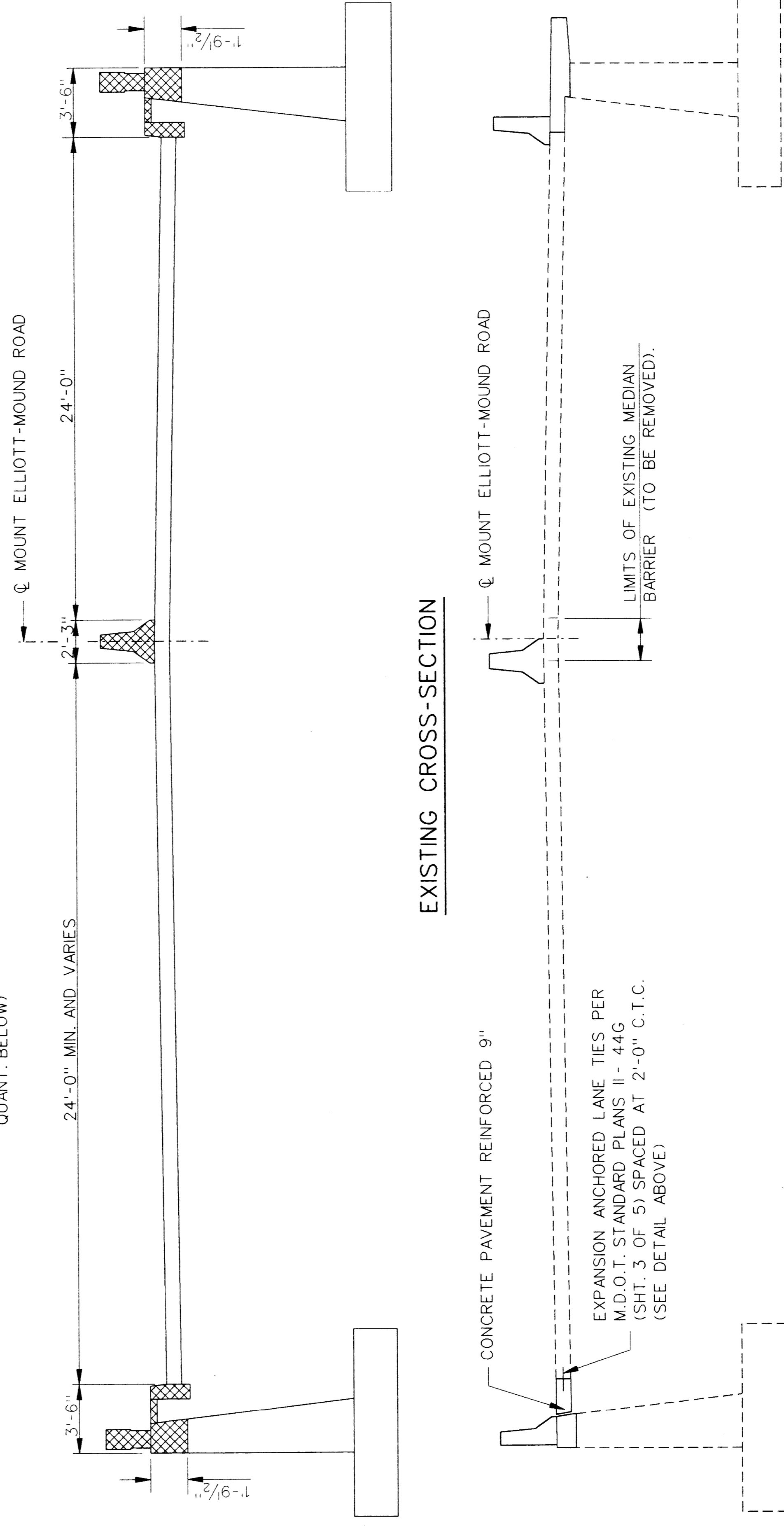

EXISTING CROSS-SECTION

PROPOSED CROSS-SECTION

MISCELLANEOUS QUANTITIES

ITEM	UNIT	AMOUNT
BRIDGE BARRIER RAILING, TYPE 5 (MOD.) FOR RAILING REPLACEMENT	LFT	1075
CONCRETE MEDIAN BARRIER (SP)	LFT	550
EPOXY ANCHORING OF VERTICAL BAR, 1/2"	EACH	1467
EPOXY ANCHORING OF VERTICAL BAR, 5/8"	EACH	530
EXPANSION-ANCHORED LANE TIES	EACH	272

LEGEND:
 HATCHED AREA DENOTES CONCRETE TO BE REMOVED, TO BE PAID AS "REMOVAL OF PORTION OF STRUCTURES (REHABILITATION)."

MICHIGAN DEPARTMENT OF TRANSPORTATION
 MOUNT ELLIOTT-MOUND ROAD BRIDGE
 IN THE CITY OF DETROIT

NORTH/SOUTH APPROACH - DETAILS

APPROVED

DESIGN SUPERVISING ENGINEER

B01 of 82-22-48

Baker
 WTA

BAKER AND ASSOCIATES
 WALTER TEAMER AND ASSOCIATES, INC.
 A JOINT ASSOCIATION
 18431 JAMES COUZENS DETROIT, MI 48235

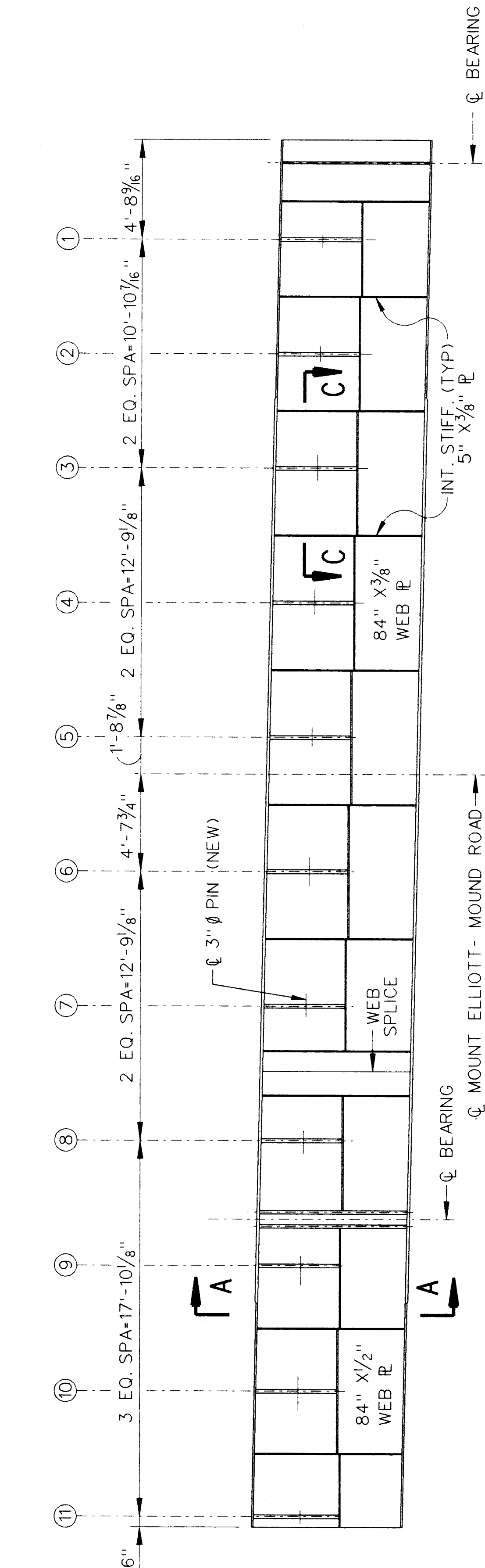

FLOORBEAM ELEVATION

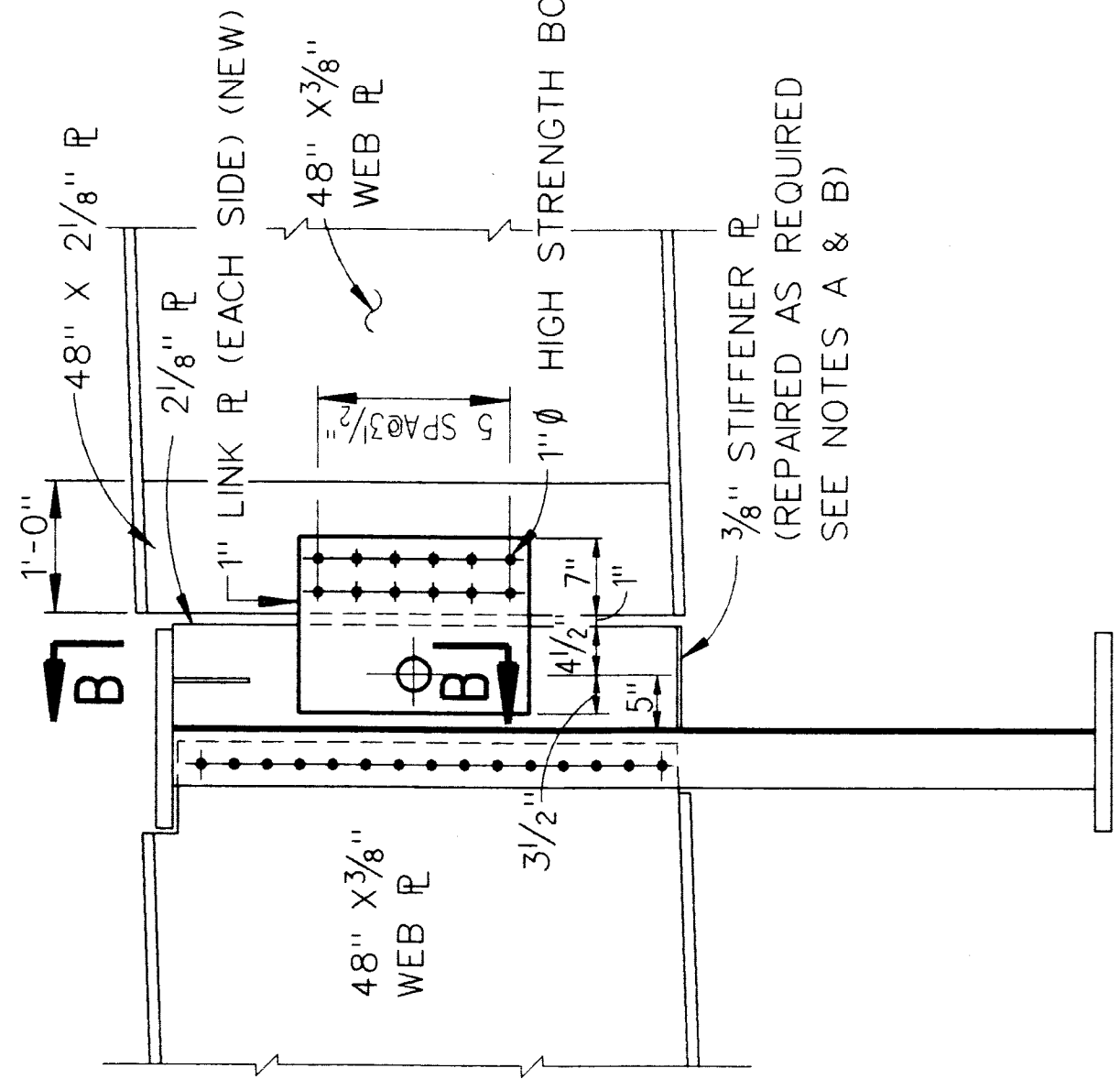

SECTION A-A

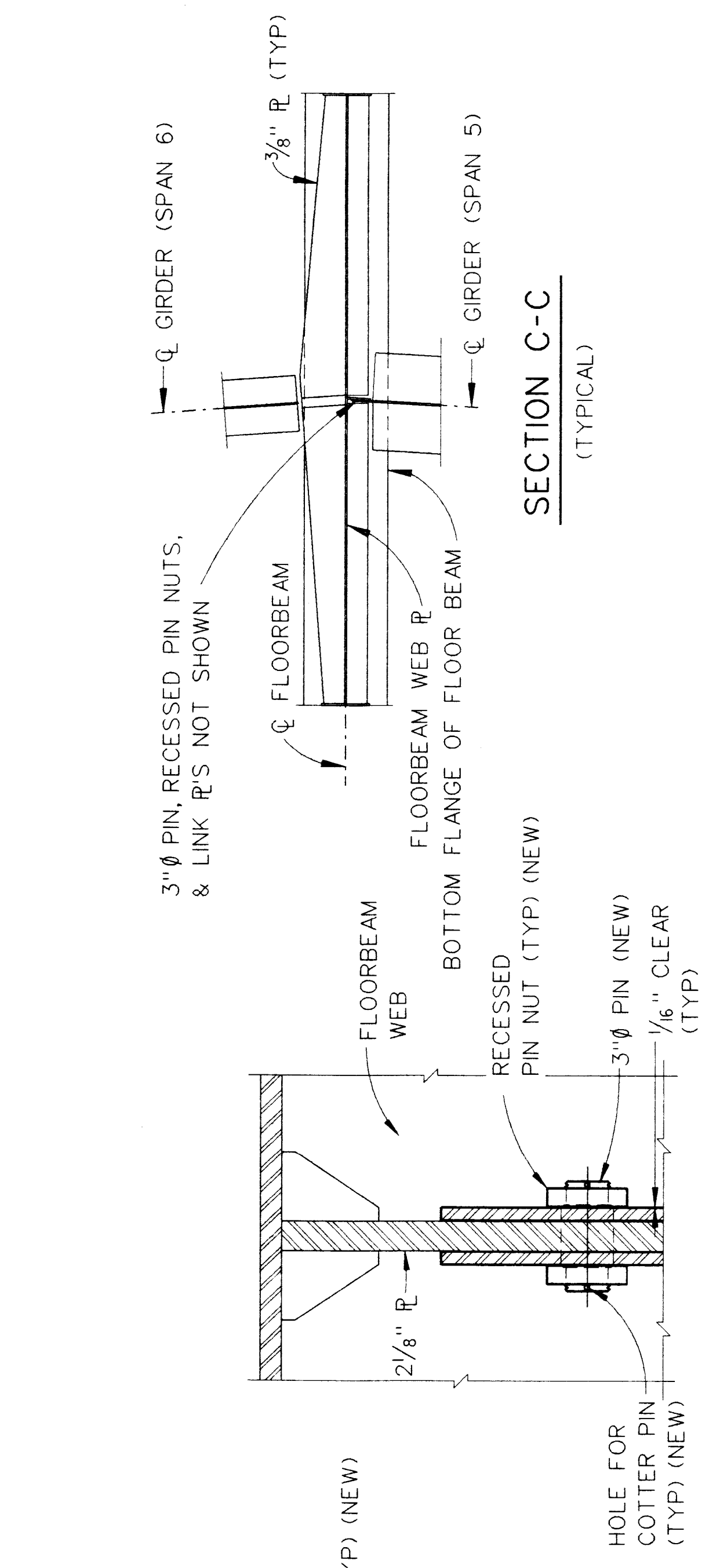

SECTION B-B

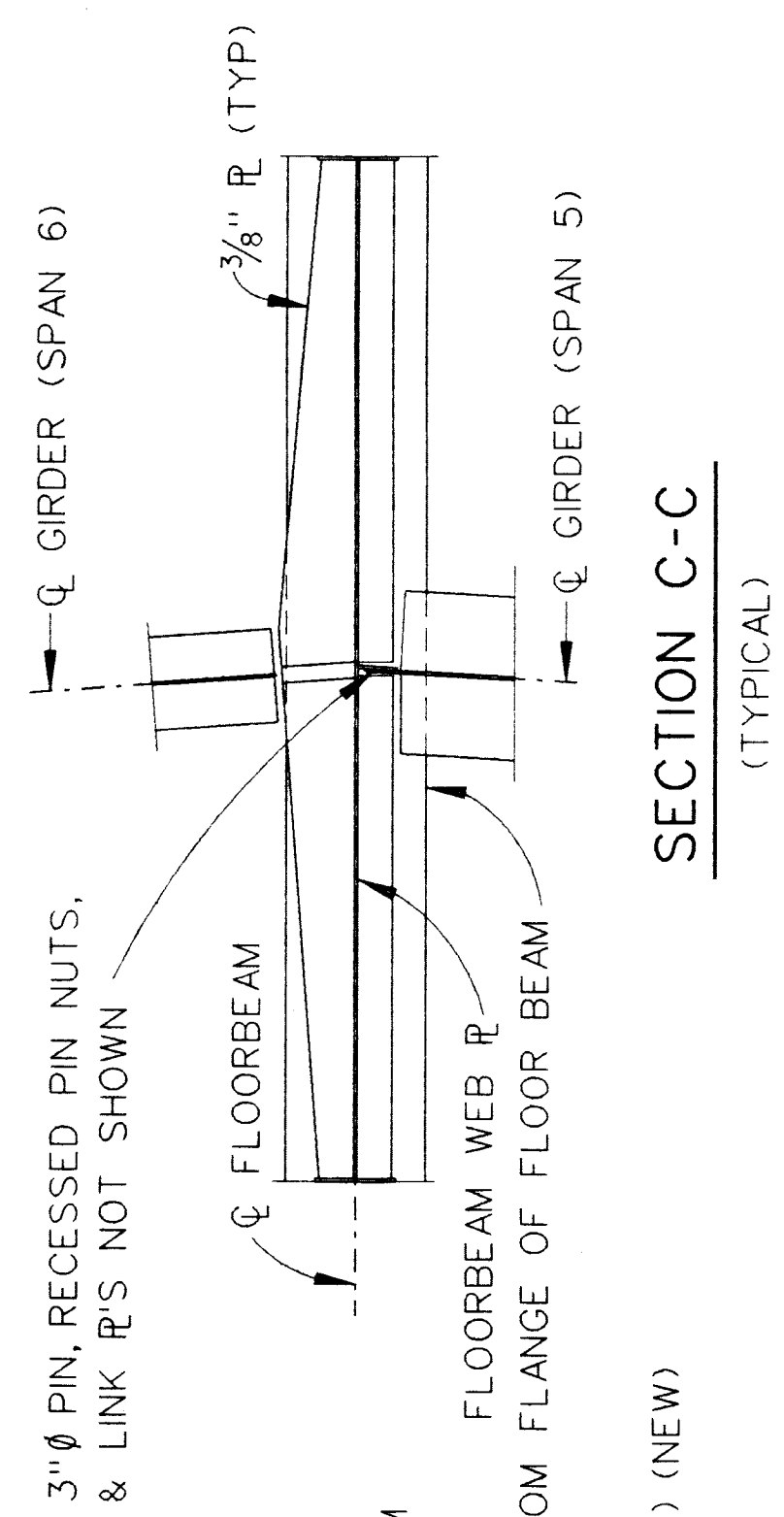

SECTION C-C
(TYPICAL)

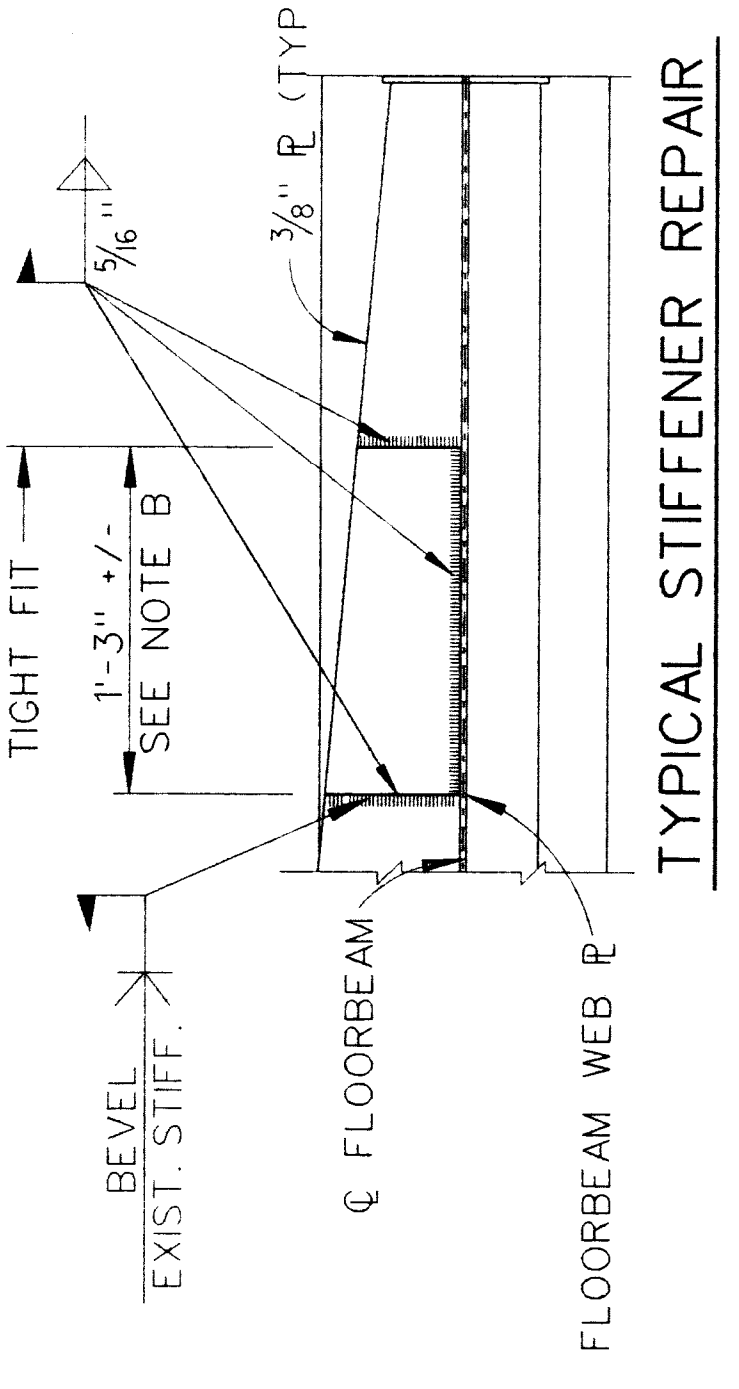

TYPICAL STIFFENER REPAIR

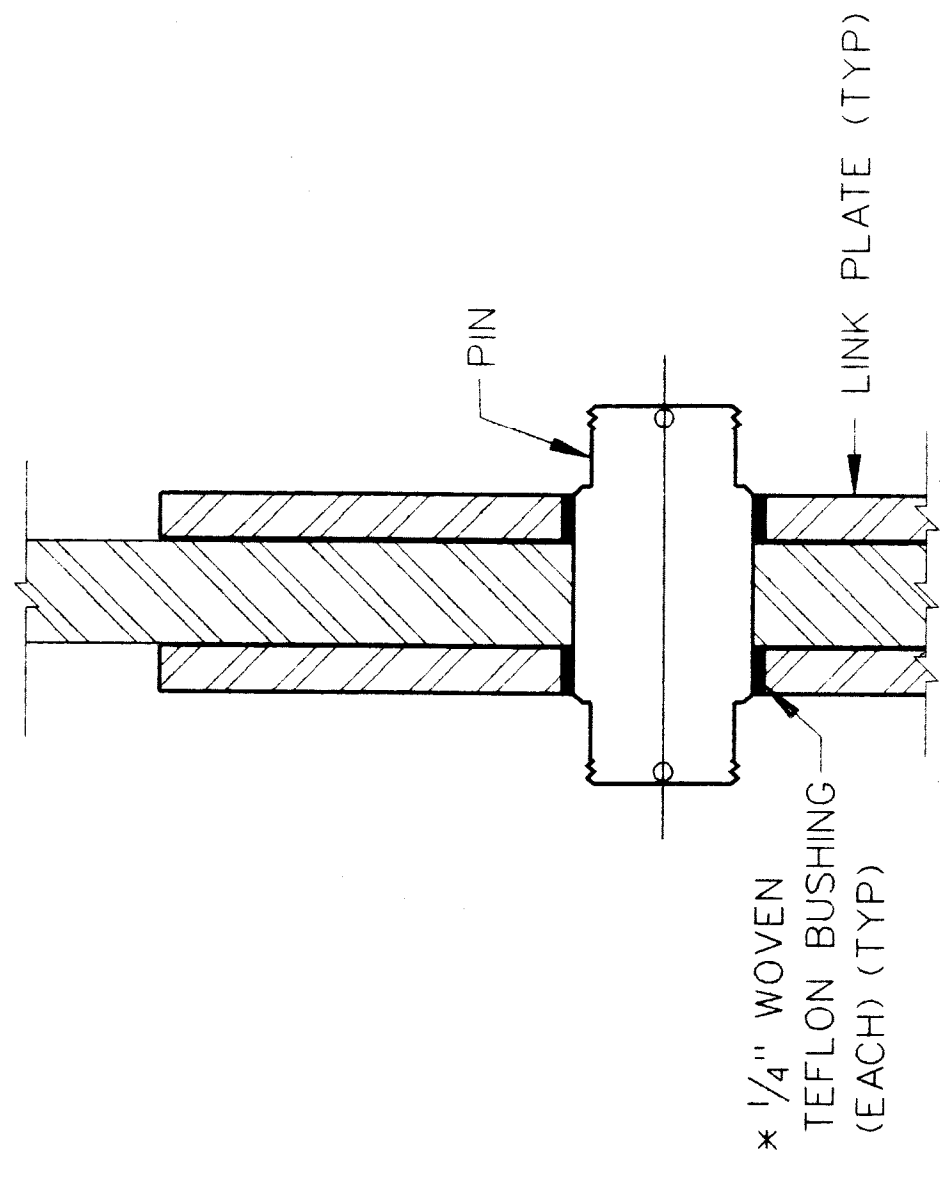

PIN DETAIL

NOTES:
 A. FIELD CUT EXISTING STIFFENER TO CLEAR NEW REPAIR MATERIAL, USING SAW, DRILL AND GRINDING. FLAME CUTTING WILL NOT BE PERMITTED WITHIN 2" OF GIRDER WEB. GRIND SURFACE AFTER CUTTING TO A SURFACE ROUGHNESS OF (Ra) 1000 OR LESS.
 B. LENGTH TO BE DETERMINED IN THE FIELD BY THE ENGINEER.

* SELF LUBRICATION FILAMENT WOUND EPOXY MATRIX BACKED DURAION BEARING OR METAL BACKED FIBER GLIDE BEARING OR EQUIVALENT.

NOTES

ALL STRUCTURAL STEEL SHALL BE FIELD PAINTED, THE AREA BEHIND AND AROUND THE HANGER SHALL BE PAINTED PRIOR TO INSTALLING THE NEW LINK PLATES AND PINS. PROPOSED LINK PLATES SHALL BE SHOP PAINTED, CLEANING, FIELD PAINTING, AND SHOP PAINTING SHALL BE DONE IN ACCORDANCE WITH THE SPECIAL PROVISIONS AND SUPPLEMENTAL SPECIFICATIONS.
 SEE SPECIAL PROVISIONS FOR PIN AND LINK PLATE MATERIAL, TEMPORARY SUPPORTS, AND REMOVAL AND ERECTION OF HANGER ASSEMBLY.
 THE CONTRACTOR SHALL TAKE FIELD MEASUREMENTS OF THE EXISTING HANGER ASSEMBLIES INDICATED ON THE PLANS PRIOR TO THE PREPARATION OF LINK PLATE AND PIN SHOP DRAWINGS. SEE SPECIAL PROVISION FOR PINS AND LINK PLATES.
 REPAIR OF COATING ON LINK PLATES SHALL BE DONE PRIOR TO ERECTION. PAID FOR AS "FIELD REPAIR OF DAMAGED COATING"
 WELDING ON EXISTING GIRDERS WILL NOT BE PERMITTED (EXCEPT AS NOTED).

WHICH BAY DR GIVE REFERENCE LOCAL TRACK

MISCELLANEOUS QUANTITIES		
ITEM	UNIT	AMOUNT
HANGER ASSEMBLY REMOVAL AND ERECTION	EACH	11
STRUCTURAL STEEL, FURNISHING AND FABRICATING (PIN & HANGER)	LBS	2300
BUSHING	EACH	22
FIELD MEASUREMENT OF HANGER ASSEMBLY	EACH	11
TEMPORARY SUPPORT, SUSPENSION TYPE	EACH	11
STRUCTURAL STEEL FABRICATION AND ERECTION (PLATES)	LBS	200

MICHIGAN DEPARTMENT OF TRANSPORTATION
 MOUNT ELLIOTT-MOUND ROAD BRIDGE
 IN THE CITY OF DETROIT
STRUCTURAL DETAILS

DESIGNED BY	NAME	RAJ	DATE	1/24
DRAWN BY	NAME	RAJ	DATE	1/24
CHECKED BY	NAME	RAW	DATE	1/24
SHEET	23	OF	54	

NO.	REVISION	DATE	BY

SUPERSTRUCTURE CONCRETE QUANTITIES

POUR	AMT (CYDS)
A	7.2
B	41.3
C	40.5
D	8.5
E	55.4
F	54.3
TOTAL CONC.: 207.2	

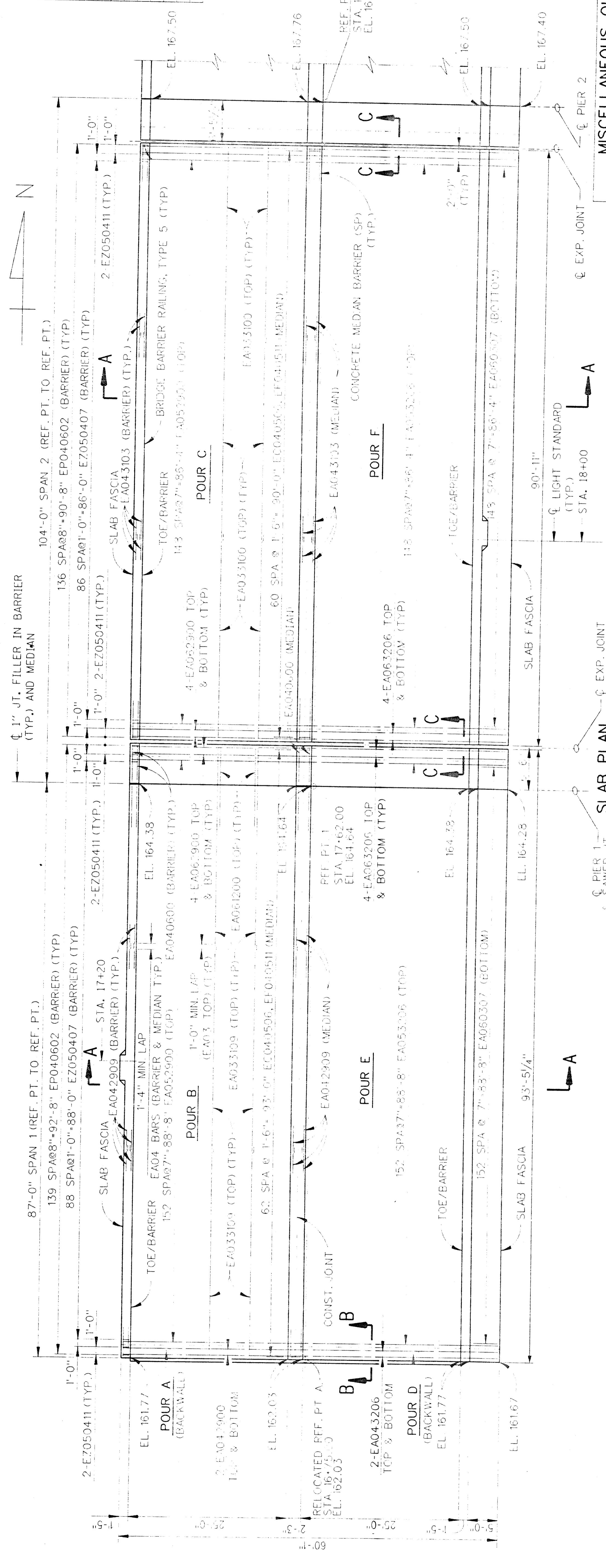

MISCELLANEOUS QUANTITIES

ITEM	UNIT	AMOUNT
FORMER, FINISHING AND CURING	SPAN 1 SPAN 2	
SUPERSTRUCTURE CONCRETE	LSUM	1
BRIDGE BARRIER RAILING, TYPE 5	LFT	196.9
BRIDGE BARRIER RAILING, TYPE 5	STO	93.4
HYDROLYSIS - FIRST PASS	STO	598.2
HYDROLYSIS - SECOND	STO	582.5
PASS	STD	6.9
BRAND CASING - TYPE 1	EACH	0
TELETYPE FEEDING-STRUCTURES	SFT	934

NOTES:
 WORK THIS SHEET WITH SHEETS 31 TO 45.

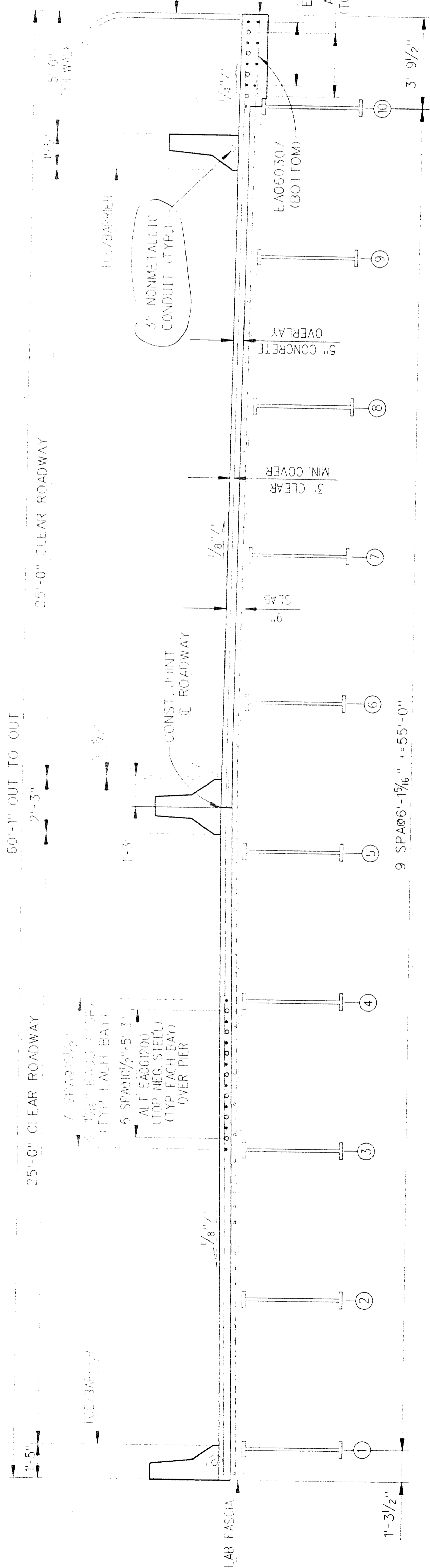

SECTION A-A

MICHIGAN DEPARTMENT OF TRANSPORTATION
 MOUNT ELLIOTT-MOUND ROAD BRIDGE
 IN THE CITY OF DETROIT
SUPERSTRUCTURE DETAILS

APPROVED: _____
 DESIGN SUPERVISING ENGINEER

NO. _____
 DESCRIPTION _____
 DATE _____
 BY _____

SQUAD	BOSS	NAME	P.N.	DATE
				6/24
				6/23

CHECKED BY	NAME	DATE
		1/24
		54

B01 of 82-22-48

Baker
WTA
 BAKER AND ASSOCIATES
 WALTER TEAMER AND ASSOCIATES, INC.
 A JOINT ASSOCIATION
 18431 JAMES COUZENS DETROIT, MI 48235

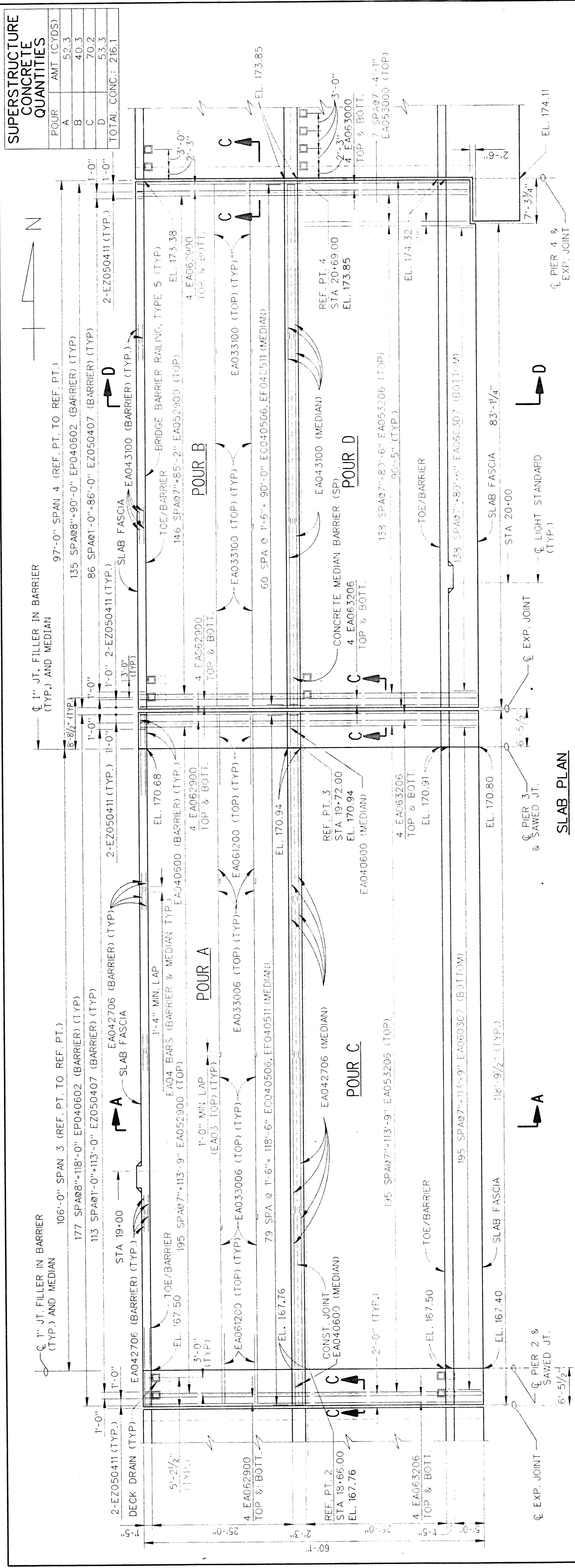

SUPERSTRUCTURE CONCRETE QUANTITIES

POUR	AMT (CYDS)
A	52.3
B	40.3
C	70.2
D	53.3
TOTAL CONC.: 216.1	

MISCELLANEOUS QUANTITIES

ITEM	UNIT	SPAN 3	SPAN 4	AMOUNT
FORMING, FINISHING AND CURING SUPERSTRUCTURE CONCRETE	LSUM	1	1	
BRIDGE BARRIER RAILING, TYPE 5 (MOD) FOR RAILING REPLACEMENT	LFT	237.5	180.8	
CONCRETE MEDIAN BARRIER (SP)	LFT	118.8	90.4	
SCAFFOLDING	SYD	760.9	579.3	
HYDRODEMOLISHING - FIRST PASS	SYD	760.9	579.3	
HYDRODEMOLISHING - SECOND PASS	SYD	43.8	6.7	
URBAN CASTINGS - TYPE 1	EACH	4	4	
PEDESTRIAL FENCING-STRUCTURES	SFT	1273	831	

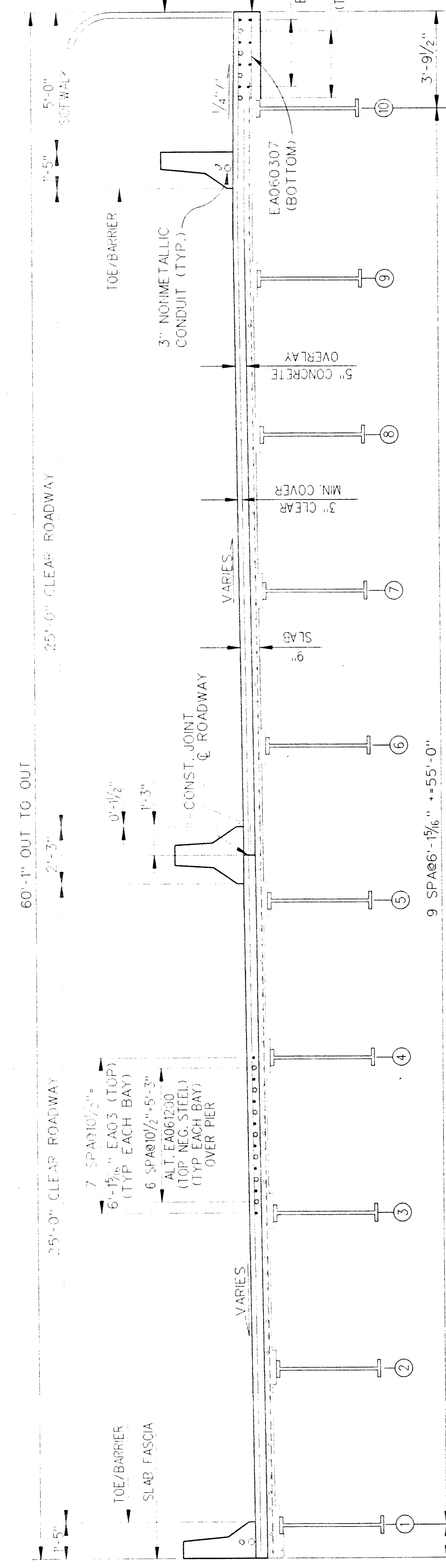

MICHIGAN DEPARTMENT OF TRANSPORTATION
MOUNT ELLIOTT-MOUND ROAD BRIDGE
IN THE CITY OF DETROIT
SUPERSTRUCTURE DETAILS

APPROVED _____
 DESIGN SUPERVISING ENGINEER

NO. _____ DESCRIPTION _____ REVISIONS _____ DATE _____ BY _____

DATE: 6/93
 NAME: WTA
 DATE: 6/93

DATE: 1/94
 NAME: WTA
 DATE: 1/94

SHEET: 31 OF 34

B01 of 82-22-48

NOTES
 WORK THIS SHEET WITH SHEETS 30 AND 32 THRU 35.

SECTION D-D

Baker
WTA
 BAKER AND ASSOCIATES
 WALTER TEAMER AND ASSOCIATES, INC.
 A JOINT ASSOCIATION
 18431 JAMES COUZENS DETROIT, MI 48235

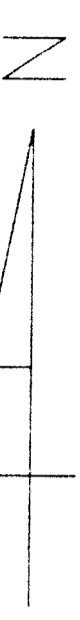

MISCELLANEOUS QUANTITIES		
ITEM	UNIT	AMOUNT
FORMING, FINISHING AND CURING SUPERSTRUCTURE CONCRETE	LSUM	1
BRIDGE BARRIER RAILING, TYPE 5 (MOD) FOR RAILING REPLACEMENT	LFT	246.3
CONCRETE MEDIAN BARRIER (SP)	LFT	122.5
SCAFFOLDING	SYD	882.3
HYDROEMULSION - FIRST PASS	SYD	882.3
HYDROEMULSION - SECOND PASS	SYD	40.6
DRAIN CASING - TYPE 1	EACH	6
PEDESTAL FINISHING STRUCTURES	SFT	1451
3" DIA. METAL CONDUIT	LFT	246.3

SUPERSTRUCTURE CONCRETE QUANTITIES		
TYPE	AMT (CYDS)	
A	53.4	
B	75.9	
TOTAL CONC.		129.3

NOTES:
 WORK THIS SHEET WITH SHEETS 30 & 31 AND 33 THRU 45.

MICHIGAN DEPARTMENT OF TRANSPORTATION
 MOUNT ELLIOTT-MOUND ROAD BRIDGE
 IN THE CITY OF DETROIT
SUPERSTRUCTURE DETAILS

DESIGNED BY	NAME	DATE
CHECKED BY	NAME	DATE
DRAWN BY	NAME	DATE
SCALE	SHEET	OF

APPROVED: _____
 DESIGN SUPERVISING ENGINEER

B01 of 82-22-48

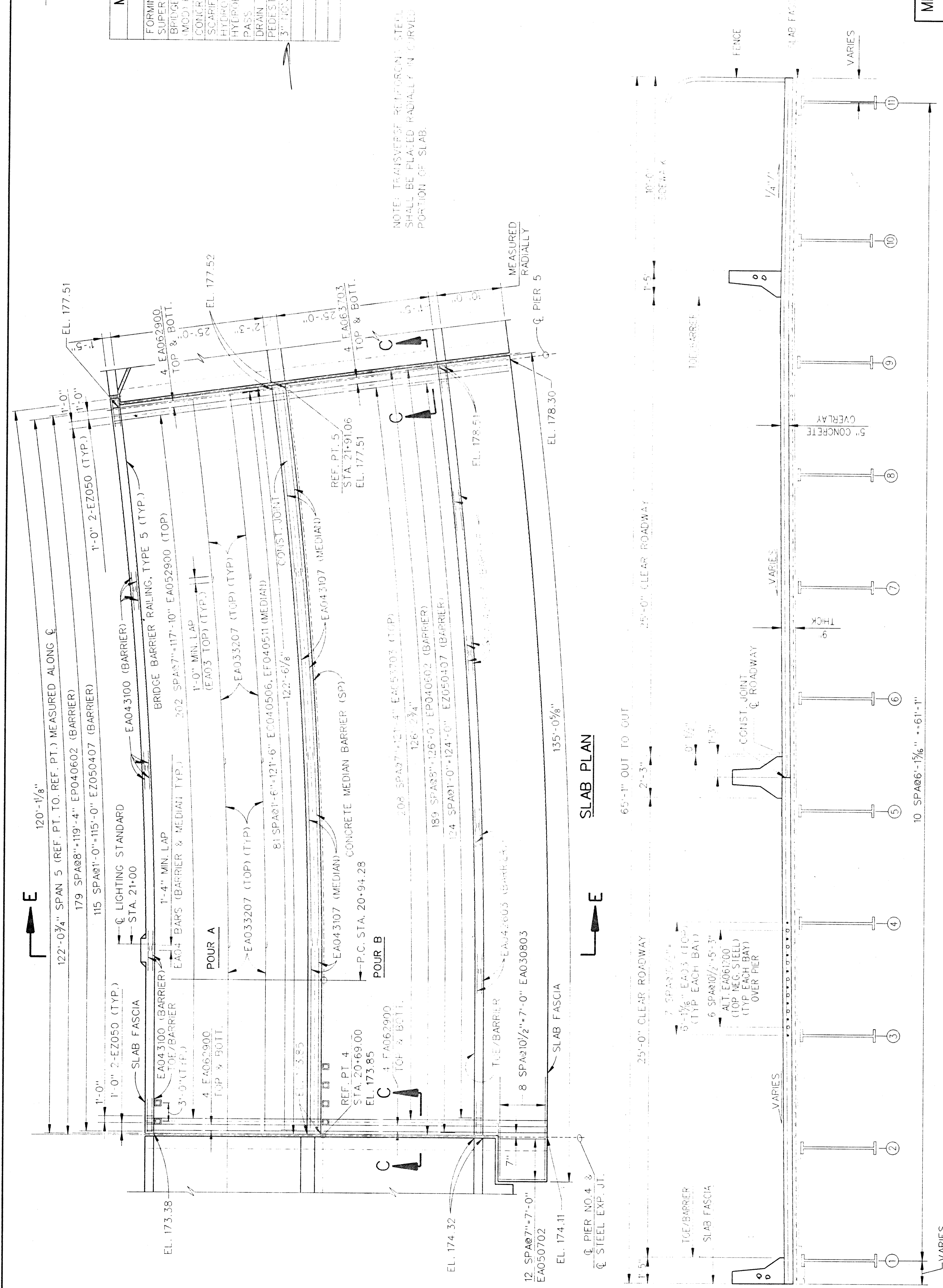

SECTION E-E

Baker
WTA
 BAKER AND ASSOCIATES
 WALTER TEAMER AND ASSOCIATES, INC.
 A JOINT ASSOCIATION
 18431 JAMES COUZENS DETROIT, MI 48235

NO.	DESCRIPTION	REVISIONS	DATE	BY

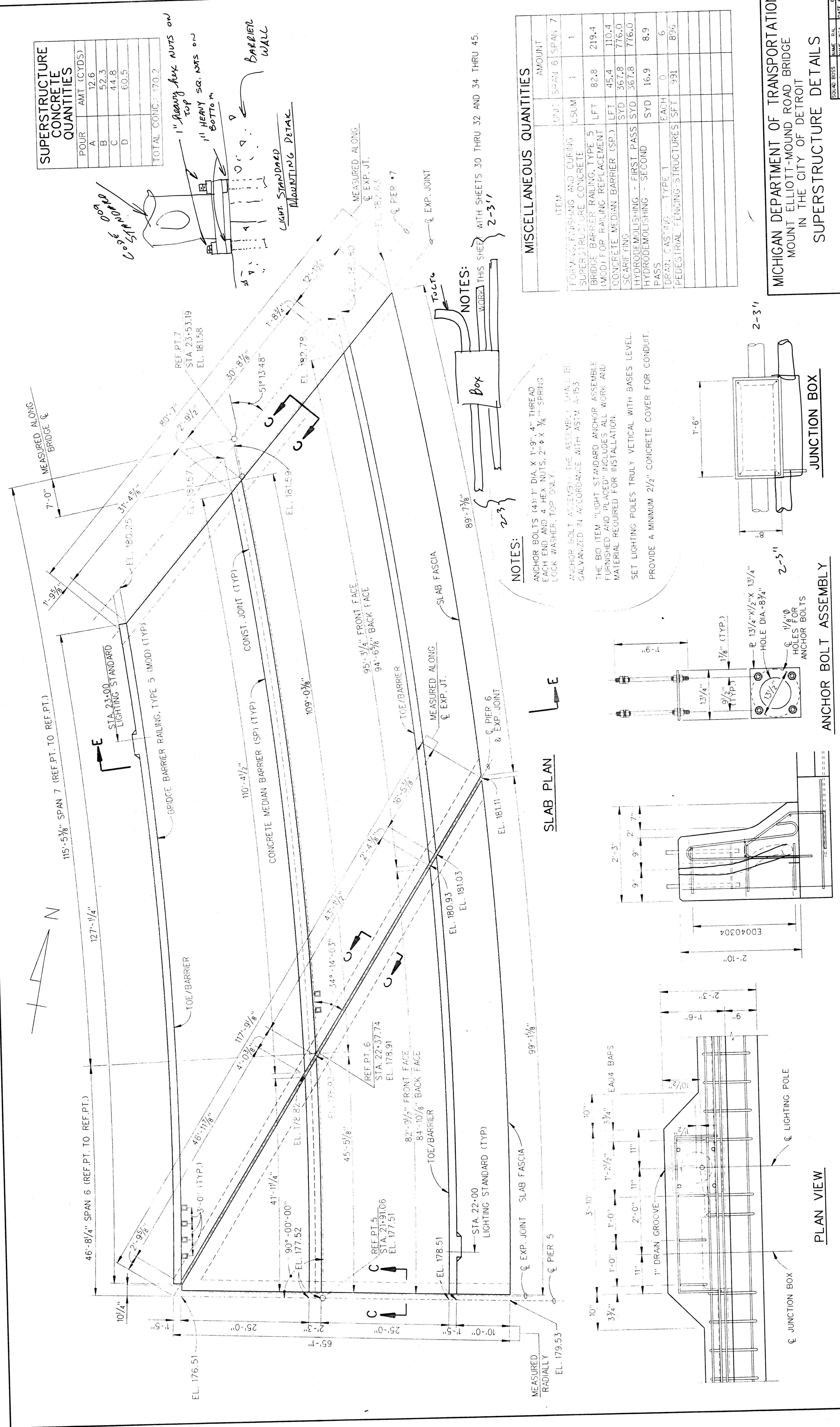

SUPERSTRUCTURE CONCRETE QUANTITIES

POUR	AMT (CYDS)
A	12.6
B	52.3
C	44.8
D	60.5
TOTAL CONC.: 170.2	

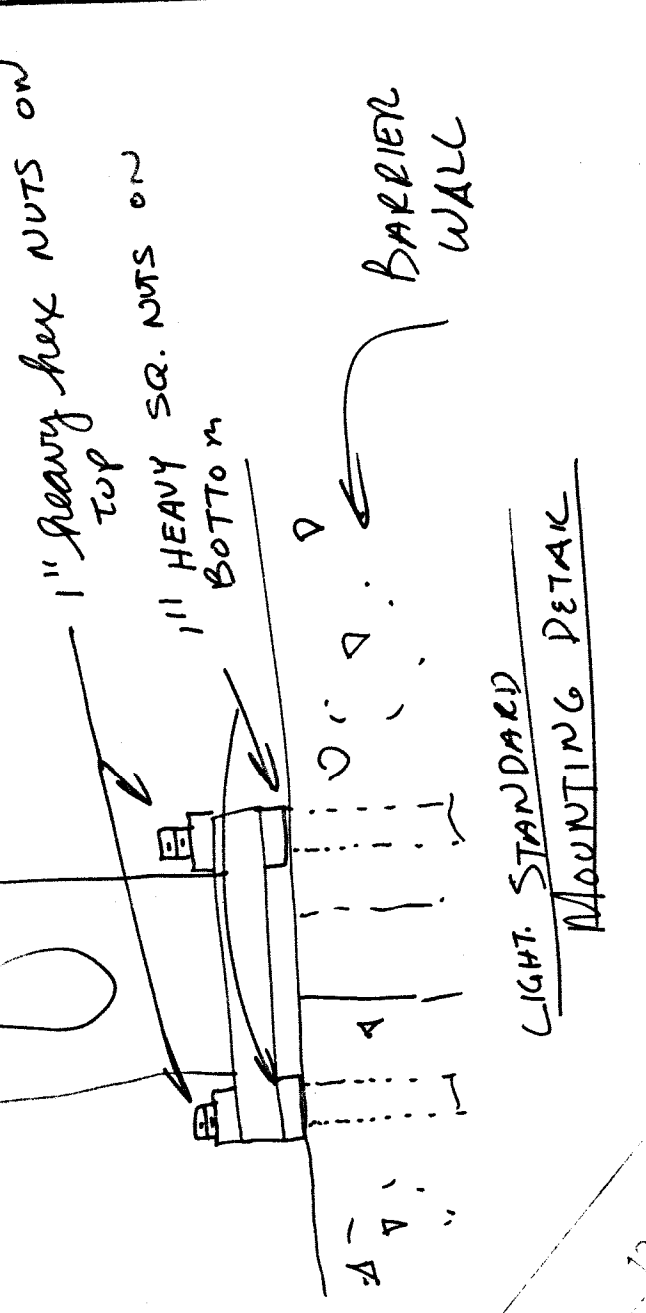

MISCELLANEOUS QUANTITIES

ITEM	UNIT	AMOUNT
FORMWORK, FINISHING AND CURING	LSUM	1
SUPERSTRUCTURE CONCRETE	LFT	82.8
BRIDGE BARRIER RAILING, TYPE 5 (MOD) FOR RAILING REPLACEMENT	LFT	45.4
CONCRETE MEDIAN BARRIER (SP.)	SYD	367.8
SCAFFOLDING	SYD	367.8
HYDRODEMOLISHING - FIRST PASS	SYD	16.9
HYDRODEMOLISHING - SECOND PASS	SYD	16.9
DRAIN CASTING - TYPE 1	EACH	0
PEDESTRIAL FENCING-STRUCTURES	SFT	991

NOTES:

- ANCHOR BOLTS (4) 1" DIA. X 1'-9", 4" THREAD EACH END AND 4" HEX NUTS, 2" X 3/8" SPRING LOCK WASHER, TOP ONLY.
- ANCHOR BOLT ASSEMBLY: THE ASSEMBLY SHALL BE GALVANIZED IN ACCORDANCE WITH ASTM A-153.
- THE BID ITEM "LIGHT STANDARD ANCHOR ASSEMBLY FURNISHED AND PLACED" INCLUDES ALL WORK AND MATERIAL REQUIRED FOR INSTALLATION.
- SET LIGHTING POLES TRULY VERTICAL WITH BASES LEVEL. PROVIDE A MINIMUM 2 1/2" CONCRETE COVER FOR CONDUIT.

SLAB PLAN

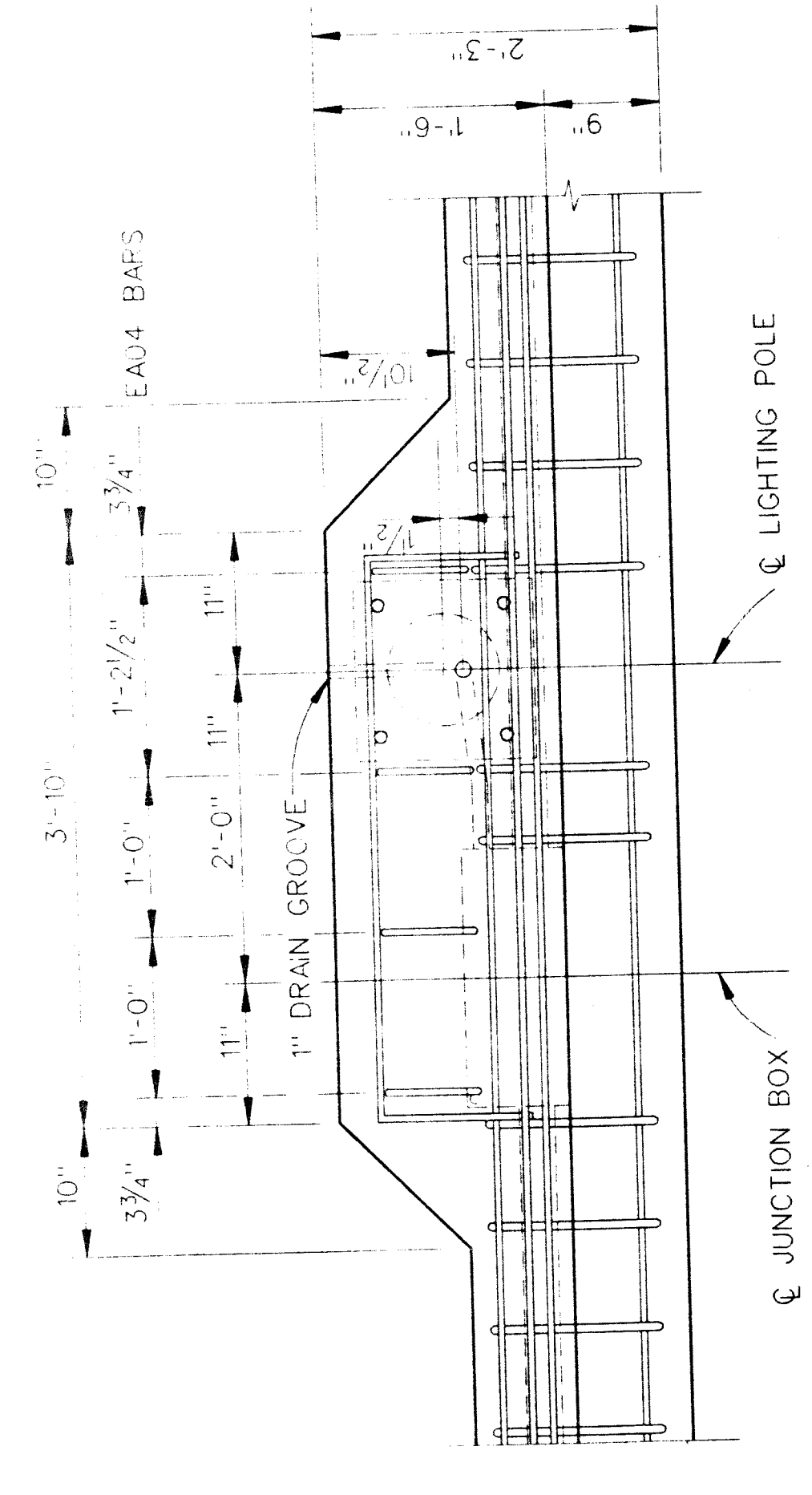

PLAN VIEW

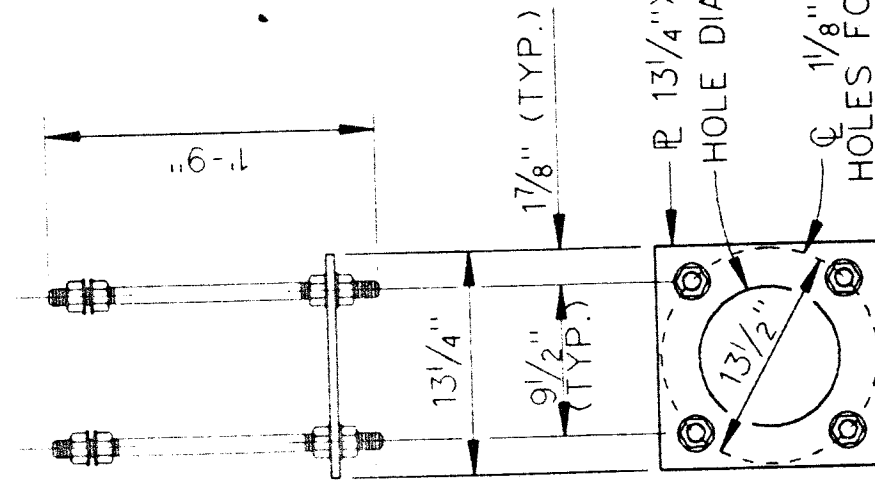

ANCHOR BOLT ASSEMBLY

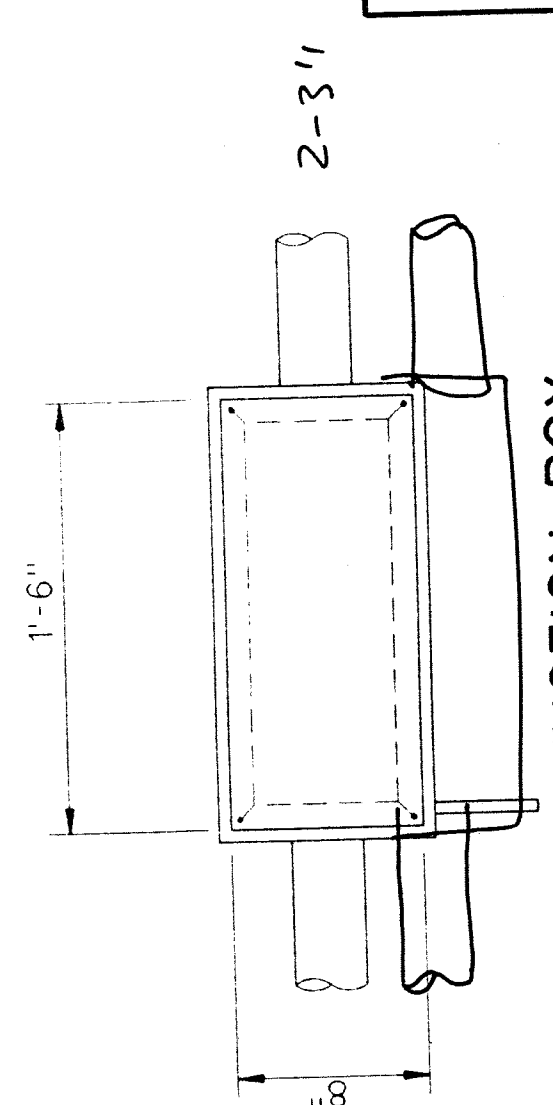

JUNCTION BOX

SECTION

MICHIGAN DEPARTMENT OF TRANSPORTATION
MOUNT ELLIOTT-MOUND ROAD BRIDGE
IN THE CITY OF DETROIT
SUPERSTRUCTURE DETAILS

APPROVED

NO.	DESCRIPTION	DATE	BY

DESIGN SUPERVISING ENGINEER

B01 of 82-22-48

MISCELLANEOUS QUANTITIES	
ITEM	UNIT AMOUNT
FORMING, FINISHING AND CURING SUPERSTRUCTURE CONCRETE	L SUM 1
BRIDGE BARRIER RAILING, TYPE 5 (MOD) FOR RAILING REPLACEMENT	LFT 247.1
CONCRETE MEDIAN BARRIER (SP.)	LFT 123.6
SCAFFOLDING	SYD 890.0
HYDRODEMOLISHING - FIRST PASS	SYD 890.0
HYDRODEMOLISHING - SECOND PASS	SYD 20.5
DRAIN CASTING - TYPE 1	EACH 12
FEEDERIAL FENCING-STRUCTURES	SFT 1238

SUPERSTRUCTURE CONCRETE QUANTITIES	
POUR	AMT. (CYDS)
A	54.3
B	74.2
TOTAL CONCR. 128.5	

NOTE:
 TRANSVERSE REINFORCING STEEL SHALL BE PLACED RADIALLY IN CURVED PORTION OF SLAB.
 LONGITUDINAL STEEL SHALL BE PLACED CONCENTRIC TO BRIDGE CENTER LINE.
 WORK THIS SHEET WITH SHEETS 30 THRU 34 AND 36 THRU 45.

SEE SHEET 25

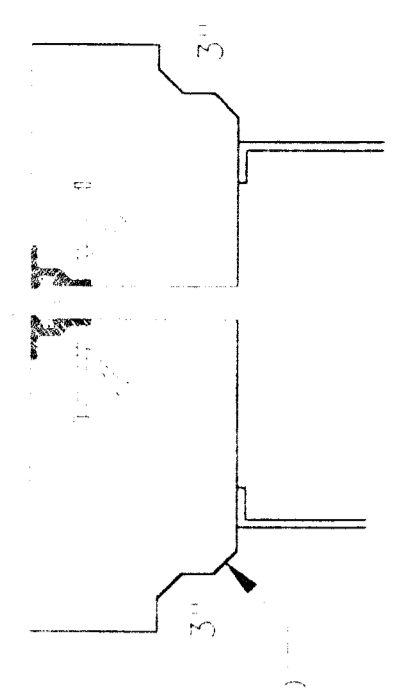

SECTION C-C

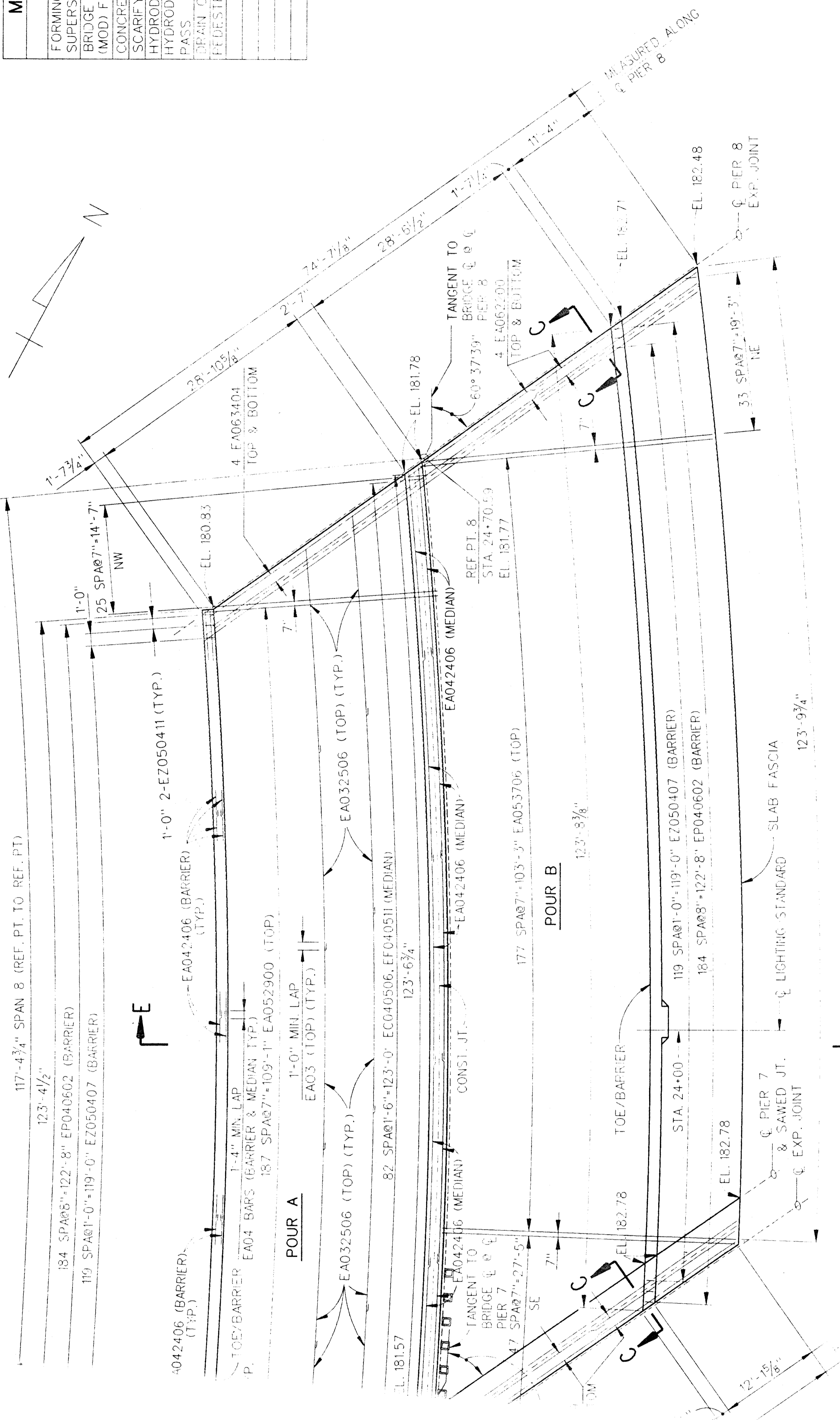

SLAB PLAN

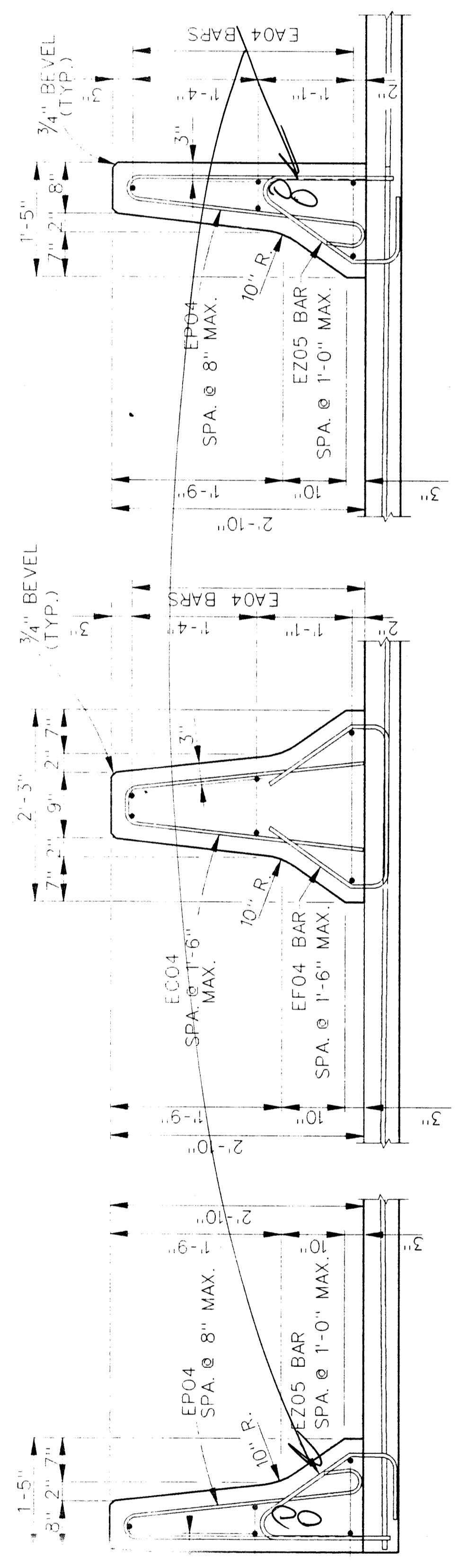

TYPICAL BARRIER SECTION AT SIDEWALK

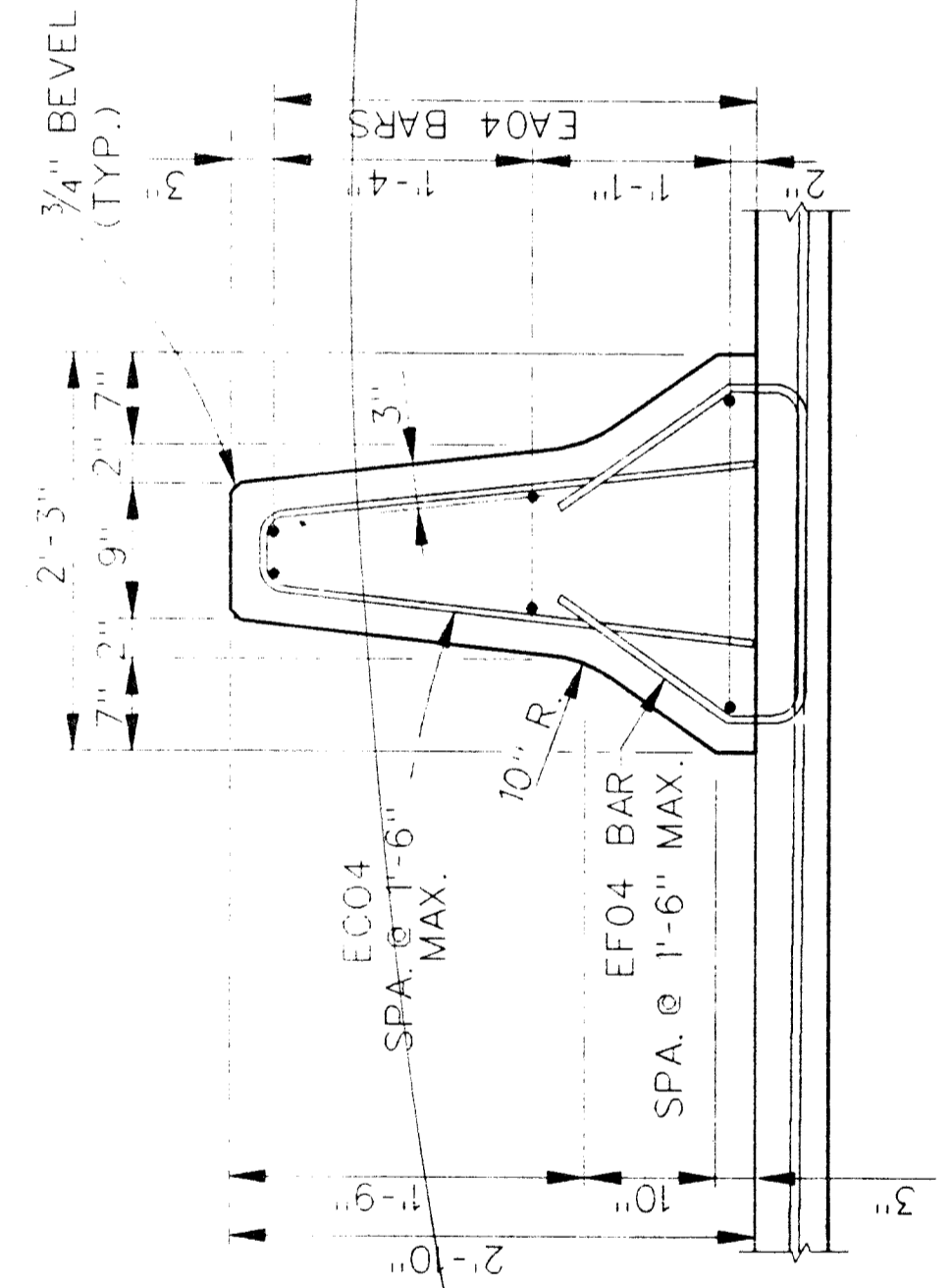

TYPICAL MEDIAN BARRIER SECTION

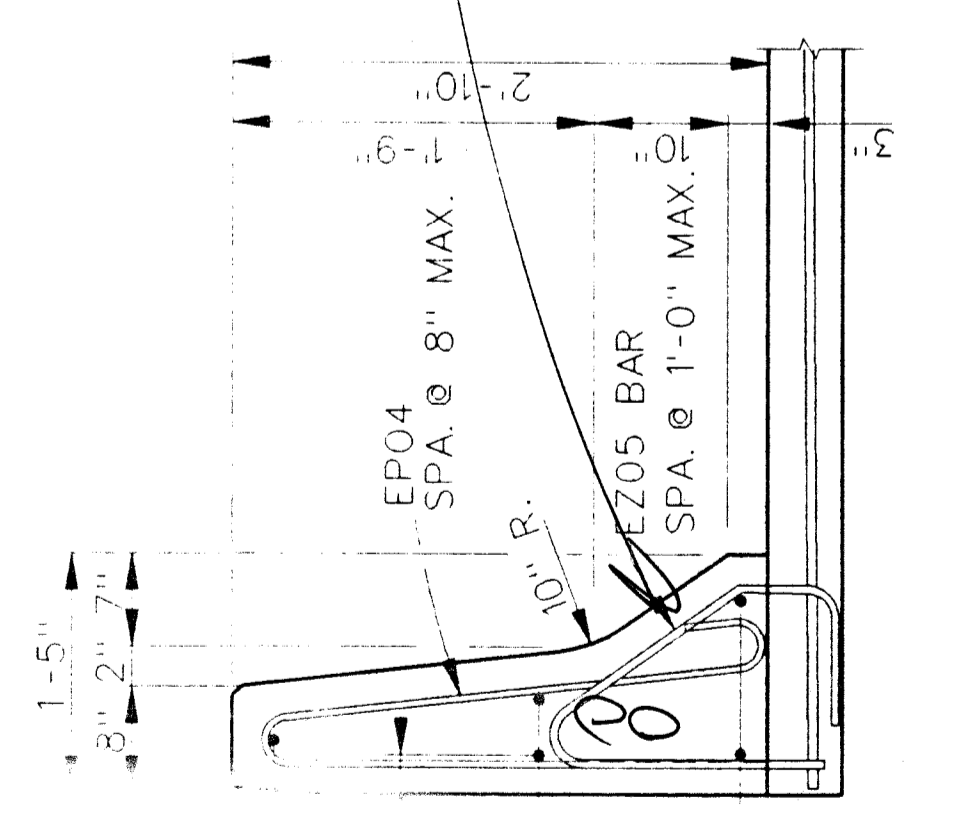

TYPICAL BARRIER SECTION

MICHIGAN DEPARTMENT OF TRANSPORTATION
 MOUNT ELLIOTT-MOUND ROAD BRIDGE
 IN THE CITY OF DETROIT
 SUPERSTRUCTURE DETAILS

DESIGNED BY	NAME	DATE
DRAWN BY	NAME	DATE
CHECKED BY	NAME	DATE
APPROVED	NAME	DATE

DESIGN SUPERVISING ENGINEER

NO.	REVISION	DATE	BY

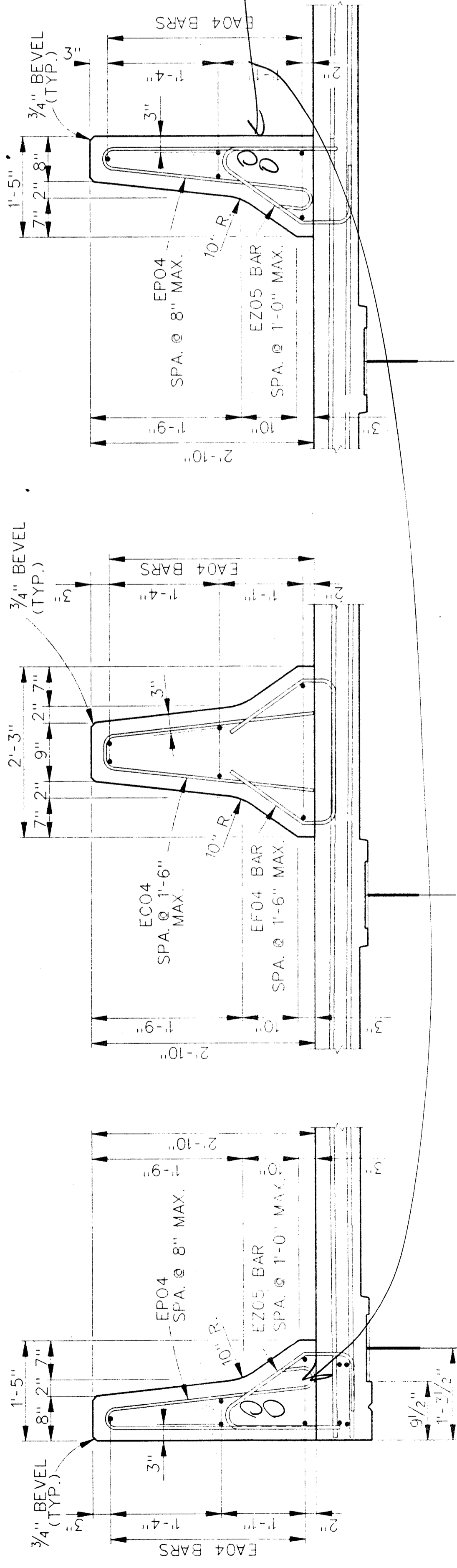

2-3" NEMA TC-6, PVC CONDUIT

SECTION GG

SECTION HH

SECTION II

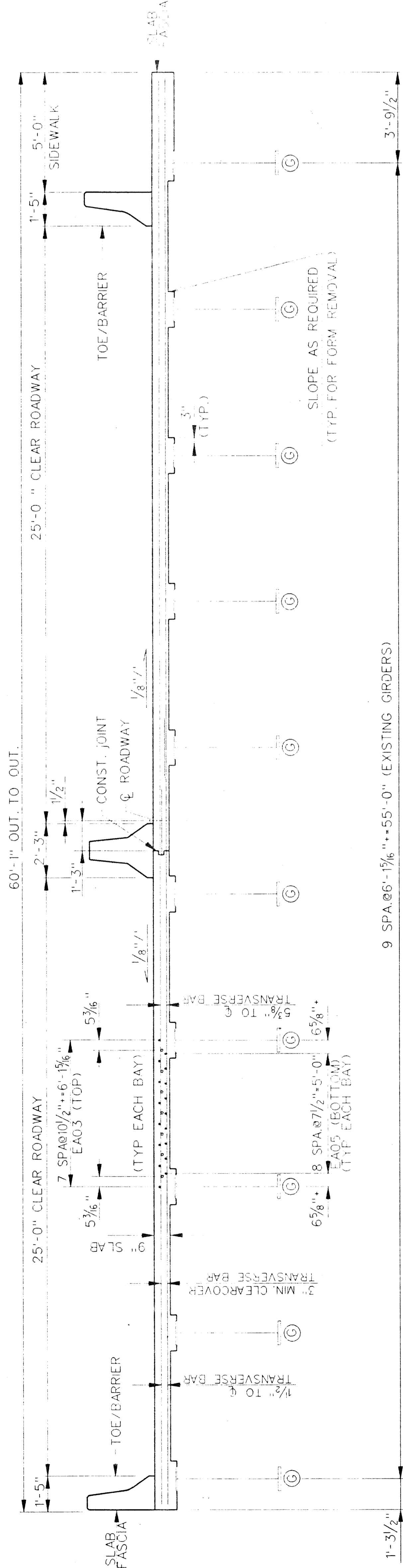

SECTION JJ

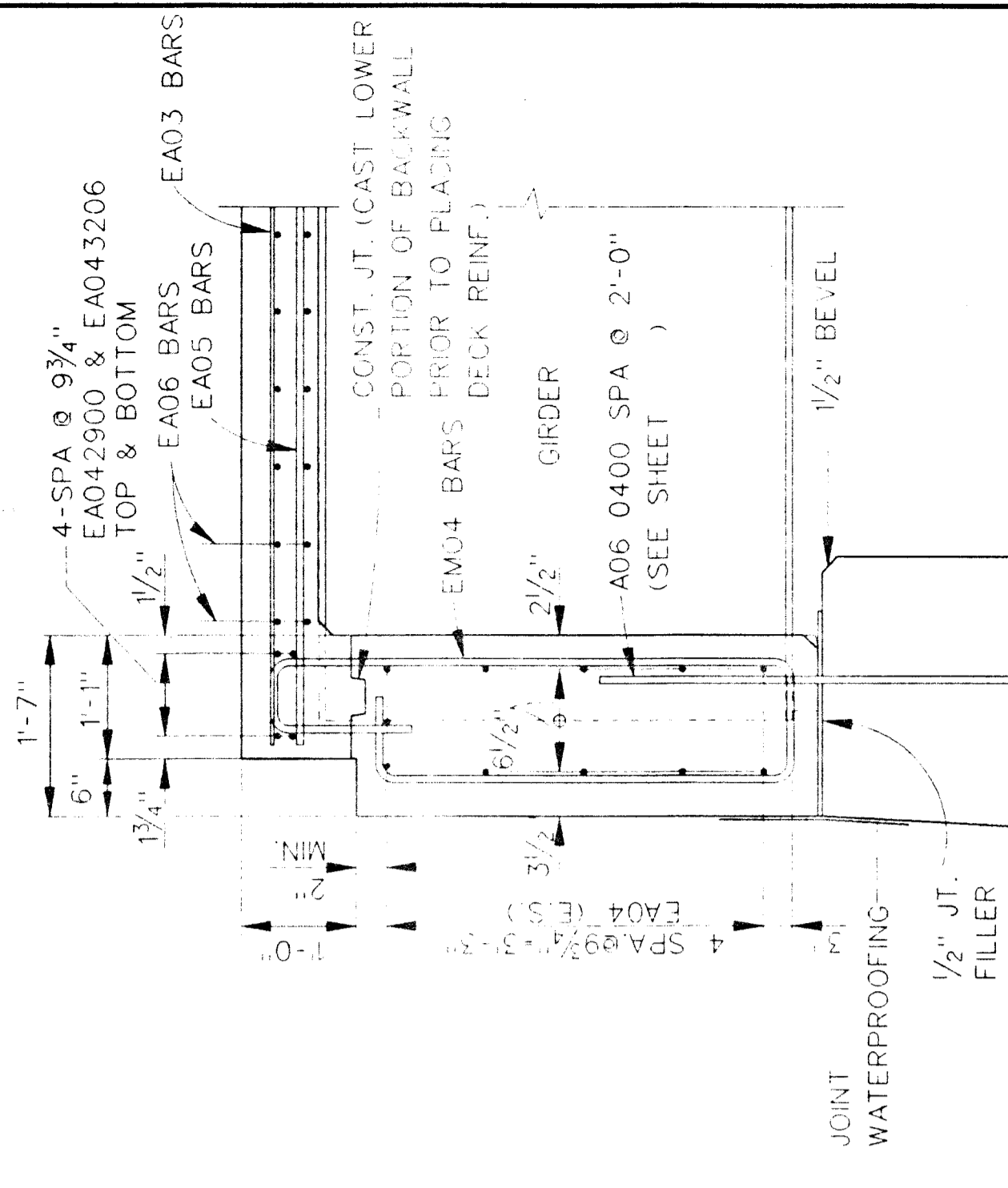

SECTION KK

SCALE: 3/4" = 1'-0"

MICHIGAN DEPARTMENT OF TRANSPORTATION
 MOUNT ELLIOTT-MOUND ROAD BRIDGE
 IN THE CITY OF DETROIT
 SUPERSTRUCTURE DETAILS

NO.	REVISIONS	DATE	BY



BAKER AND ASSOCIATES
 WALTER TEAMER AND ASSOCIATES, INC.
 A JOINT ASSOCIATION
 18431 JAMES COUZENS DETROIT, MI 48235

DESIGN SUPERVISING ENGINEER
 APPROVED
 SHEET 41 OF 54
 DATE 1/94
 DATE 1/93

BAR	DIMENSIONS								NO. REQ'D	TOTAL WT.
	A	B	C	D	E	F	G	H		
SOUTH APPROACH										
EA030300	3'-0"								253	285
EA040503	5'-3"								253	887
EA041900	19'-0"								7	89
EA042009	20'-9"								7	97
EA042809	28'-9"								30	575
EA043009	30'-9"								30	616
EA044009	40'-9"								207	5635
EC040408	0"	3'-6"	2 1/8"	1'-3 1/8"	1'-2"	0"	0"		253	789
EC040508	3"	6"	3"	2'-7"	2'-7"	2'-7"	2'-7"		200	822
EP040602	2'-5 3/4"	6 1/4"	2'-4"	3 3/4"	1 1/2"	2'-3 3/4"	2 3/4"	3"	1162	4787
EZ040307	1'-2 1/2"	4 1/2"	1'-3 3/4"	9 1/4"	0"	0"	9"		600	1434
EZ050309	1'-4 1/2"	3 3/4"	1'-3 3/4"	9 1/4"	0"	0"	9"	1'-1"	380	1486
EZ050411	1'-7"	3 3/4"	1'-3 3/4"	10"	10 1/2"	0"	9"		395	2025
TOTAL SOUTH APPROACH STEEL REINFORCEMENT										
TOTAL SOUTH APPROACH STEEL REINFORCEMENT, EPOXY COATED										
TOTAL SOUTH APPROACH STEEL REINFORCEMENT, EPOXY COATED										

BAR	DIMENSIONS								NO. REQ'D	TOTAL WT.
	A	B	C	D	E	F	G	H		
TOTAL STEEL REINFORCEMENT										
TOTAL STEEL REINFORCEMENT, EPOXY COATED										

BAR	DIMENSIONS								NO. REQ'D	TOTAL WT.
	A	B	C	D	E	F	G	H		
TOTAL STEEL REINFORCEMENT										
TOTAL STEEL REINFORCEMENT, EPOXY COATED										

BAR	DIMENSIONS								NO. REQ'D	TOTAL WT.
	A	B	C	D	E	F	G	H		
NORTH APPROACH										
EA030300	3'-0"								100	113
EA040503	5'-3"								100	351
EA042406	24'-6"								6	98
EA043803	38'-3"								124	3168
EC040408	0"	3'-6"	2 1/8"	1'-3 1/8"	1'-2"	0"	0"		100	312
EC040508	3"	6"	3"	2'-7"	2'-7"	2'-7"	2'-7"		167	632
EP040602	2'-5 3/4"	6 1/4"	2'-4"	3 3/4"	1 1/2"	2'-3 3/4"	2 3/4"	3"	450	1854
EZ040307	1'-2 1/2"	4 1/2"	1'-3 3/4"	9 1/4"	0"	0"	9"		500	1197
EZ050309	1'-4 1/2"	3 3/4"	1'-3 3/4"	9"	0"	0"	9"	1'-1"	150	587
EZ050411	1'-7"	3 3/4"	1'-3 3/4"	10"	10 1/2"	0"	9"		150	769
TOTAL NORTH APPROACH STEEL REINFORCEMENT										
TOTAL NORTH APPROACH STEEL REINFORCEMENT, EPOXY COATED										
TOTAL NORTH APPROACH STEEL REINFORCEMENT, EPOXY COATED										

BAR	DIMENSIONS								NO. REQ'D	TOTAL WT.
	A	B	C	D	E	F	G	H		
TOTAL STEEL REINFORCEMENT										
TOTAL STEEL REINFORCEMENT, EPOXY COATED										

BAR	DIMENSIONS								NO. REQ'D	TOTAL WT.
	A	B	C	D	E	F	G	H		
TOTAL STEEL REINFORCEMENT										
TOTAL STEEL REINFORCEMENT, EPOXY COATED										

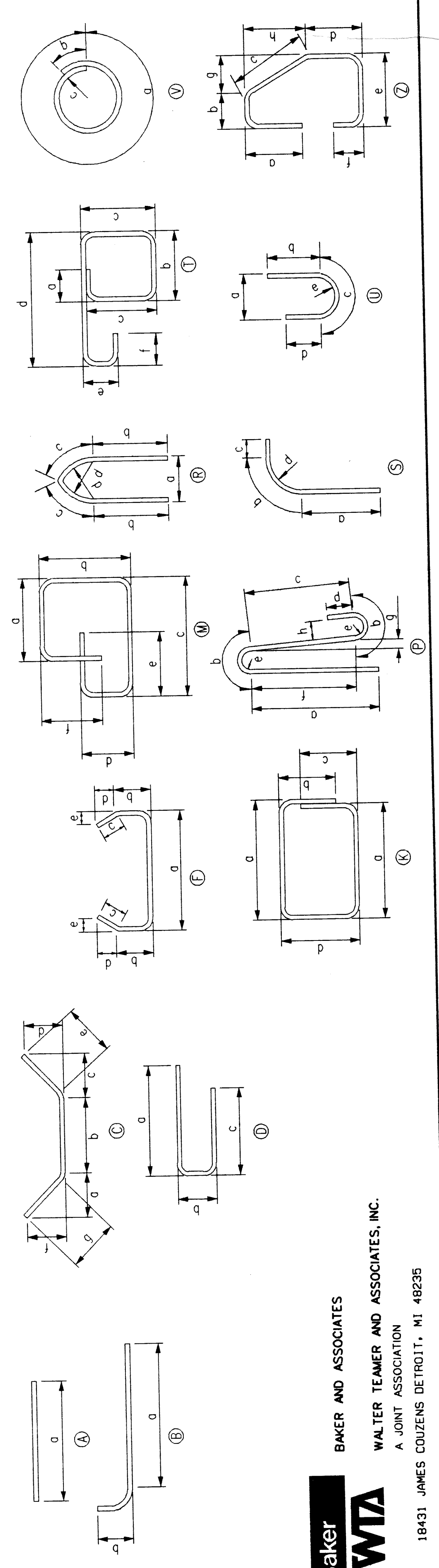

NOTES: ALL BENDS IN REINFORCING STEEL TO BE MADE ABOUT A PIN OF THE MINIMUM DIAMETER ALLOWED BY THE STANDARD SPECIFICATION.

TOLERANCES IN CUTTING AND BENDING BARS ARE AS ESTABLISHED IN MANUAL OF STANDARD PRACTICE OF THE REINFORCING STEEL INSTITUTE AND DETAILING MANUAL OF THE AMERICAN CONCRETE INSTITUTE.

WHERE FIELD CUTTING OF EPOXY BARS IS REQUIRED, THE CONTRACTOR SHALL REPAIR THE EPOXY COATING AT THE CUT END AS PROVIDED FOR IN SUPPLEMENTAL SPECIFICATION 5.03 (3 SERIES). (INCLUDED IN STEEL REINFORCEMENT, EPOXY COATED.)

REINFORCEMENT SHALL BE BUNDLED AND TAGGED AS TO THE LOCATION AS SHOWN ON THIS SHEET.

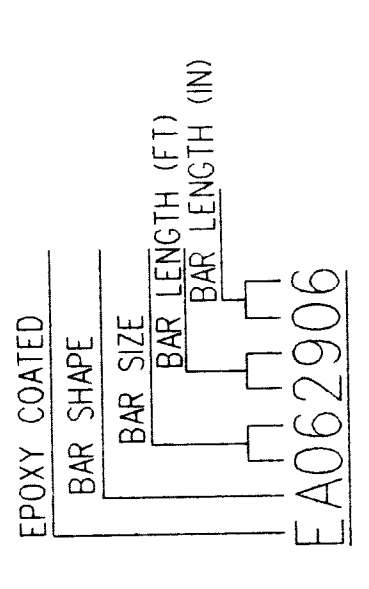

MICHIGAN DEPARTMENT OF TRANSPORTATION
 MOUNT ELLIOTT-MOUND ROAD BRIDGE
 IN THE CITY OF DETROIT
REINFORCEMENT BAR LIST

DESIGNED BY	NAME	DATE
CHECKED BY	NAME	DATE
SHEET	OF	
45	54	

APPROVED
 DESIGN SUPERVISING ENGINEER
 B01 OF 82-22-48

MAP 3
 CIRCUIT - CONNER 311
 SET - 50KVA
 LOAD - 19KVA
 SECTION - 23
 PAGE - 507

MISCELLANEOUS QUANTITIES

ITEM	QUANTITIES			
	UNIT	SHEET 1	SHEET 2	TOTAL
250 WATT HIGH PRESSURE SODIUM LUMINAIRE	EACH	15	8	23
REFURBISHING EXISTING POLE	EACH	16	8	24
3-INCH PVC, SCHEDULE 40 CONDUIT IN PARAPET	L.F.	2200	2100	4300
3-INCH PVC, SCHEDULE 40, DIRECT BURIAL CONDUIT	L.F.	300	20	500
#2 AWG, 2 KV CABLE	L.F.	7200	6900	14100
JUNCTION BOX IN BARRIER WALL	EACH	15	8	23

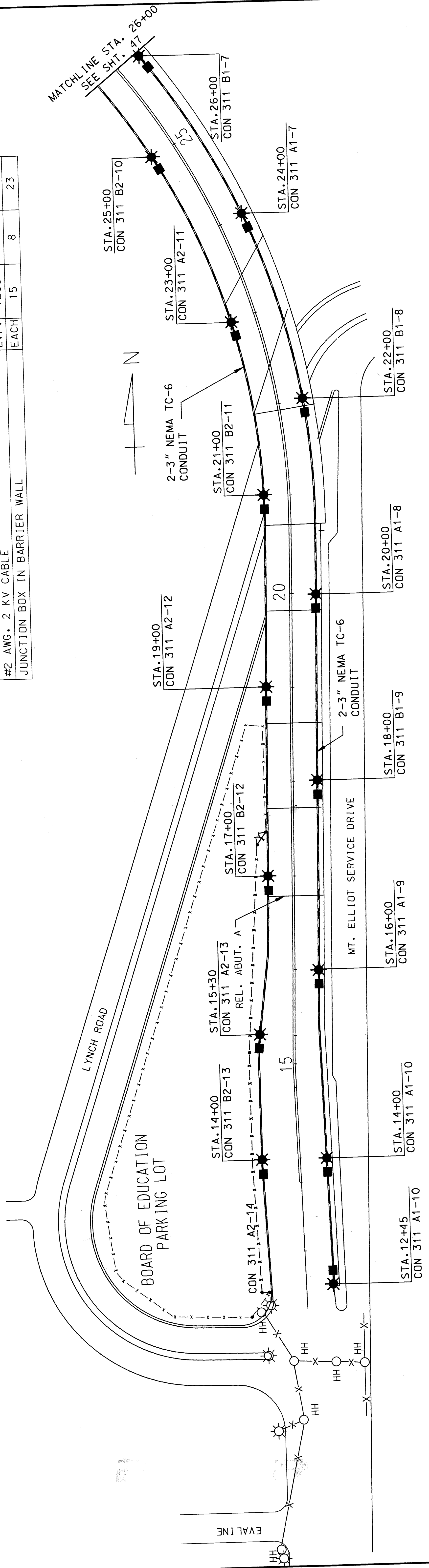

LEGEND

- BUILD 2-3 INCH, NEMA TC-6 PVC CONDUIT AND ENCASE IN BRIDGE BARRIER WALL. CONDUIT RUN BETWEEN JUNCTION BOXES TO BE 2-3 INCH; LATERAL TO LIGHT TO BE 1-3 INCH.
- ☼ REMOVE EXISTING CODE 009 STREET LIGHTING STANDARD, 6 FT. BRACKET ARM AND EXISTING 250 W. HPSV, 480 VOLT COBRA HEAD LUMINAIRE. RETURN STANDARD, BRACKET TO PLD FOR ISSUE OF A NEW STANDARD AND BRACKET ARM, AND RETURN LUMINAIRE TO PLD. INSTALL NEW CODE 009 STANDARD, BRACKET ARM AND PROVIDED 250 WATT HIGH PRESSURE SODIUM LUMINAIRE ON NEW BARRIER WALL WITH A 1 1/2 INCH BOLT CIRCLE FOUNDATION. DOUBLE-NUT THE STANDARD.
- JUNCTION BOX IN BARRIER, SEE BRIDGE DRAWING FOR DETAILS.
- _{HH} EXISTING HANDHOLE TO REMAIN
- X — EXISTING CONDUIT.
- ☼ EXISTING POLE TO REMAIN. (NO WORK REQUIRED)

GENERAL NOTES

- NO "FLEX CONDUIT" IS ALLOWED ON THE PLD SYSTEM.
- NO CONDUIT ENCASMENT IS TO BE POURED BEFORE IT IS INSPECTED BY THE PLD INSPECTOR (MR. KEN HARDWAY, PHONE 313-267-6043).
- CONTACT THE PLD SYSTEM OPERATOR AT 313-224-0500 FOR RED-TAG CLEARANCE 36 HOURS BEFORE WORKING ON ANY PLD CIRCUIT.



BAKER AND ASSOCIATES
 WALTER TEAMER AND ASSOCIATES, INC.
 A JOINT ASSOCIATION
 18431 JAMES COUZENS DETROIT, MI 48235

MICHIGAN DEPARTMENT OF TRANSPORTATION
 MOUNT ELLIOTT-MOUND ROAD BRIDGE
 IN THE CITY OF DETROIT
 LIGHTING DETAILS

APPROVED

DESIGN SUPERVISING ENGINEER

B01 of 82-22-48

DESIGNED BY	NAME	GS	DATE	1948
DRAWN BY	NAME	DIF	DATE	
CHECKED BY	NAME		DATE	
SHEET	NO.	OF	S4	

NO.	DESCRIPTION	DATE	BY

MAP 3
 CIRCUIT - CONNER 311
 SET - 50KVA
 LOAD - 19KVA
 SECTION - 23
 PAGE - 507

MATCHLINE STA. 26+00
 SEE SHT. 46

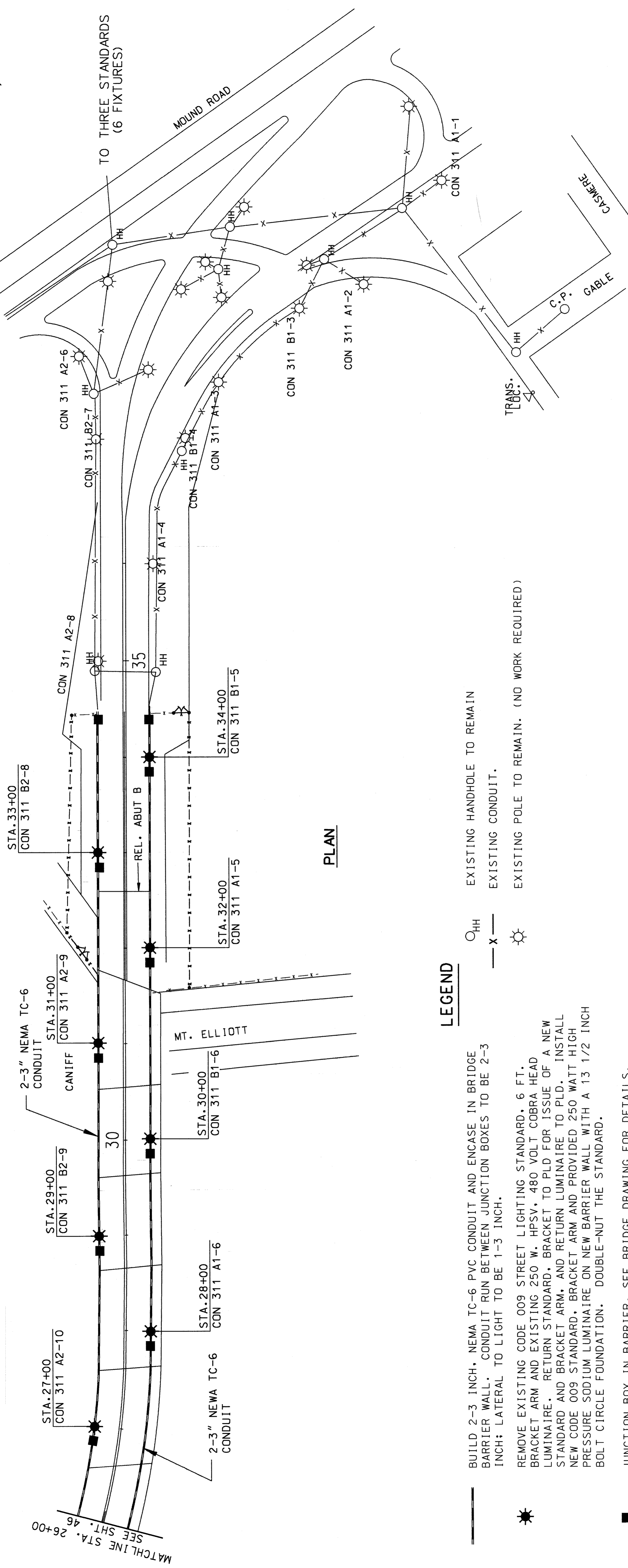

LEGEND

- BUILD 2-3 INCH, NEMA TC-6 PVC CONDUIT AND ENCASE IN BRIDGE BARRIER WALL. CONDUIT RUN BETWEEN JUNCTION BOXES TO BE 2-3 INCH; LATERAL TO LIGHT TO BE 1-3 INCH.
- ★ REMOVE EXISTING CODE 009 STREET LIGHTING STANDARD, 6 FT. BRACKET ARM AND EXISTING 250 W. HPSV, 480 VOLT COBRA HEAD LUMINAIRE. RETURN STANDARD, BRACKET TO PLD FOR ISSUE OF A NEW STANDARD AND BRACKET ARM, AND RETURN LUMINAIRE TO PLD. INSTALL NEW CODE 009 STANDARD, BRACKET ARM AND PROVIDED 250 WATT HIGH PRESSURE SODIUM LUMINAIRE ON NEW BARRIER WALL WITH A 13 1/2 INCH BOLT CIRCLE FOUNDATION. DOUBLE-NUT THE STANDARD.
- JUNCTION BOX IN BARRIER, SEE BRIDGE DRAWING FOR DETAILS.
- _{HH} EXISTING HANDHOLE TO REMAIN
- X — EXISTING CONDUIT.
- ☀ EXISTING POLE TO REMAIN. (NO WORK REQUIRED)

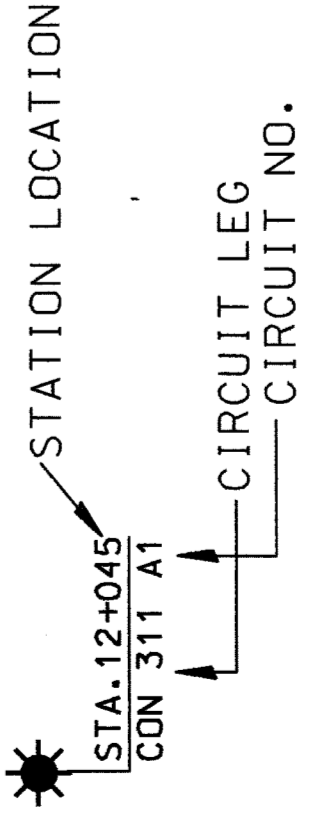

GENERAL NOTES

- NO "FLEX CONDUIT" IS ALLOWED ON THE PLD SYSTEM.
- NO CONDUIT ENCASMENT IS TO BE POURED BEFORE IT IS INSPECTED BY THE PLD INSPECTOR (MR. KEN HARDWAY, PHONE 313-267-6043).
- CONTACT THE PLD SYSTEM OPERATOR AT 313-224-0500 FOR RED-TAG CLEARANCE 36 HOURS BEFORE WORKING ON ANY PLD CIRCUIT.

Baker
WTA
 BAKER AND ASSOCIATES
 WALTER TEAMER AND ASSOCIATES, INC.
 A JOINT ASSOCIATION
 18431 JAMES COUZENS DETROIT, MI 48235

NO.	DESCRIPTION	DATE	BY

APPROVED
 DESIGN SUPERVISING ENGINEER

MICHIGAN DEPARTMENT OF TRANSPORTATION
 MOUNT ELLIOTT-MOUND ROAD BRIDGE
 IN THE CITY OF DETROIT
 LIGHTING DETAILS

SQUAD BOSS	NAME	DATE

DATE	DATE	DATE

B01 of 82-22-48

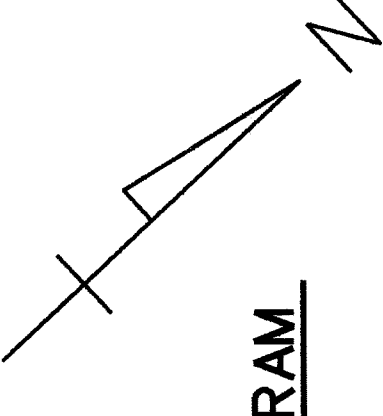
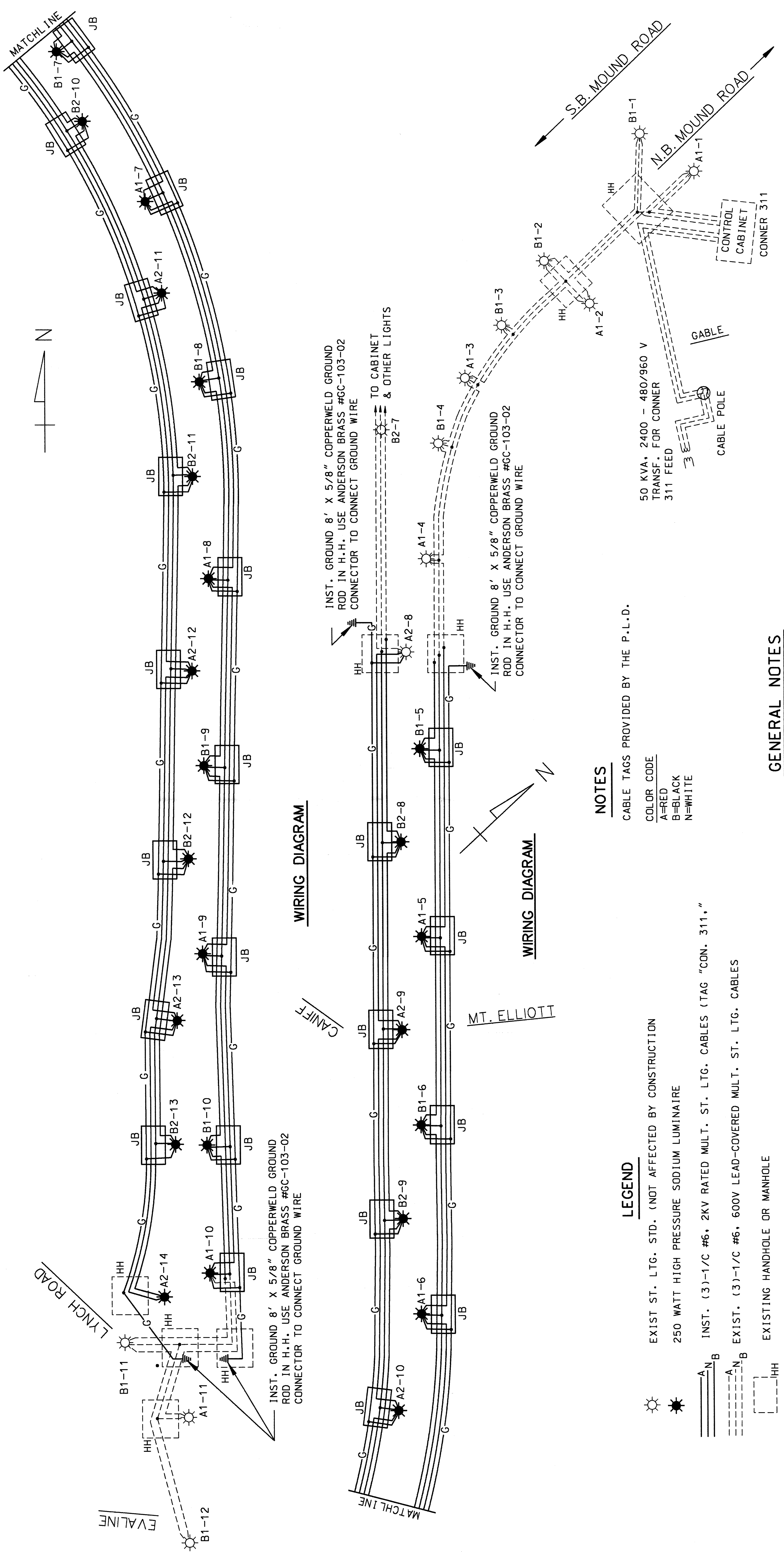

WIRING DIAGRAM

WIRING DIAGRAM

NOTES

CABLE TAGS PROVIDED BY THE P.L.D.

COLOR CODE
 A=RED
 B=BLACK
 N=WHITE

LEGEND

- EXIST. ST. LTG. STD. (NOT AFFECTED BY CONSTRUCTION)
- 250 WATT HIGH PRESSURE SODIUM LUMINAIRE
- INST. (3)-1/C #6, 2KV RATED MULT. ST. LTG. CABLES (TAG "CON. 311,"
- EXIST. (3)-1/C #6, 600V LEAD-COVERED MULT. ST. LTG. CABLES
- EXISTING HANDHOLE OR MANHOLE
- PROPOSED JUNCTION BOX IN NEW BARRIER WALL
- JB

GENERAL NOTES

NO "FLEX CONDUIT" IS ALLOWED ON THE PLD SYSTEM.
 NO CONDUIT ENCASMENT IS TO BE POURED BEFORE IT IS INSPECTED BY THE PLD INSPECTOR (MR. KEN HARDWAY, PHONE 313-267-6043).
 CONTACT THE PLD SYSTEM OPERATOR AT 313-224-0500 FOR RED-TAG CLEARANCE 36 HOURS BEFORE WORKING ON ANY PLD CIRCUIT.

50 KVA, 2400 - 480/960 V
 TRANSF. FOR CONNER
 311 FEED
 CABLE POLE
 GABLE

INST. GROUND 8' X 5/8" COPPERWELD GROUND ROD IN H.H. USE ANDERSON BRASS #GC-103-02 CONNECTOR TO CONNECT GROUND WIRE TO CABINET & OTHER LIGHTS

INST. GROUND 8' X 5/8" COPPERWELD GROUND ROD IN H.H. USE ANDERSON BRASS #GC-103-02 CONNECTOR TO CONNECT GROUND WIRE

INST. GROUND 8' X 5/8" COPPERWELD GROUND ROD IN H.H. USE ANDERSON BRASS #GC-103-02 CONNECTOR TO CONNECT GROUND WIRE

MICHIGAN DEPARTMENT OF TRANSPORTATION
 MOUNT ELLIOTT-MOUND ROAD BRIDGE
 IN THE CITY OF DETROIT
LIGHTING DETAILS

DESIGNED BY	DATE	BY
CHECKED BY	DATE	
APPROVED	DATE	
DESIGN SUPERVISING ENGINEER		

B01 of 82-22-48



BAKER AND ASSOCIATES
 WALTER TEAMER AND ASSOCIATES, INC.
 A JOINT ASSOCIATION
 18431 JAMES COUZENS DETROIT, MI 48235

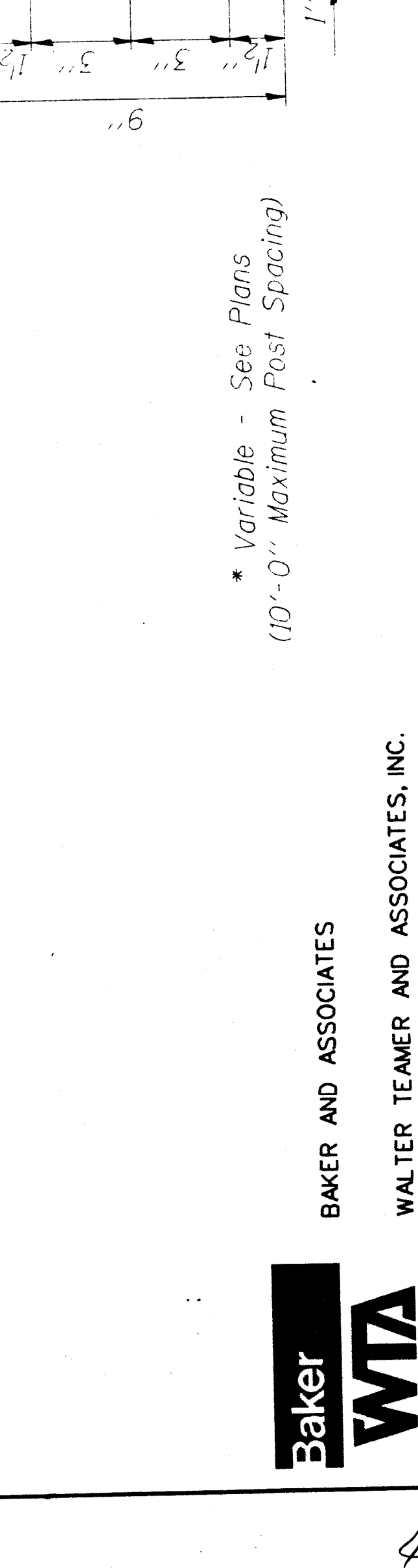
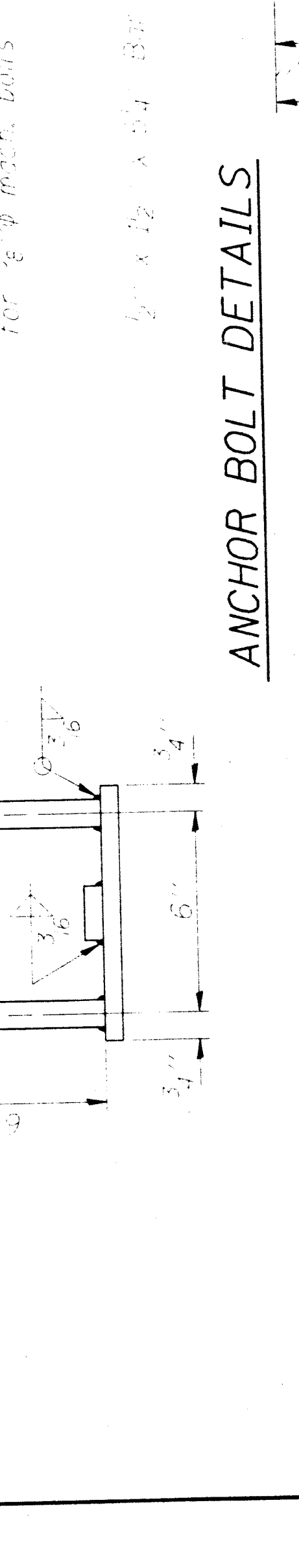
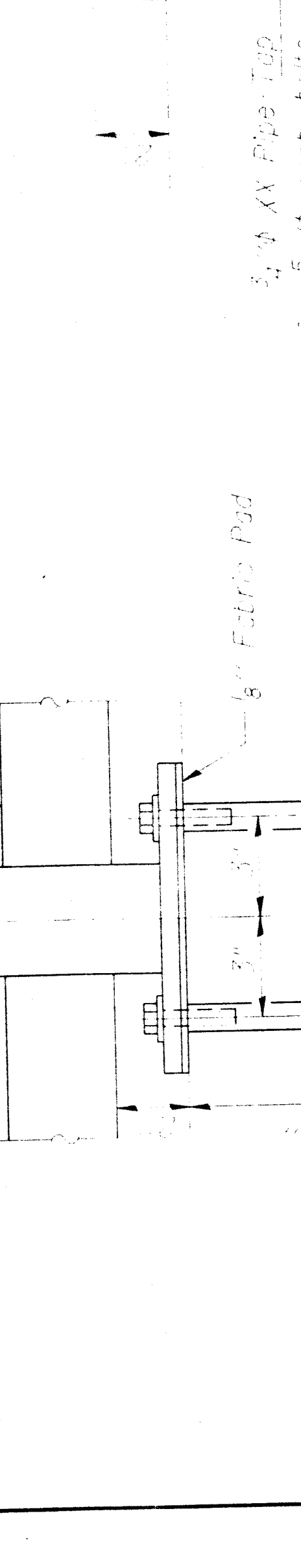
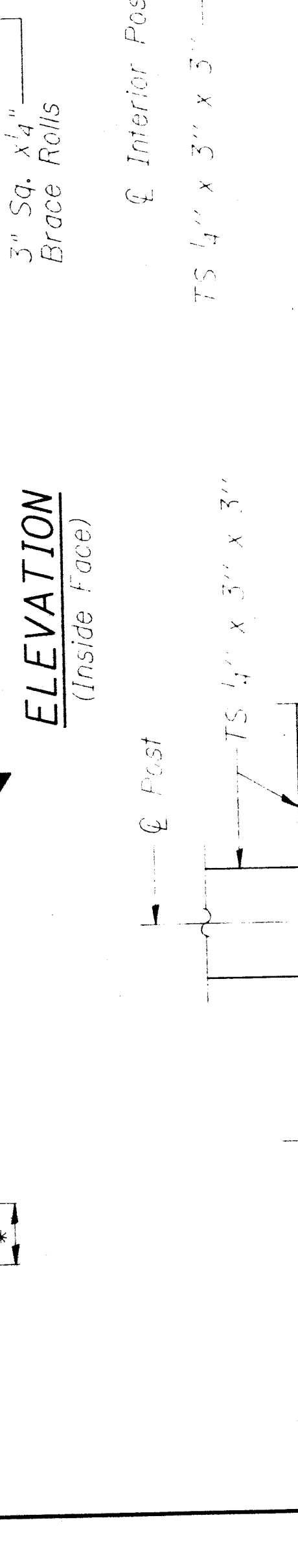
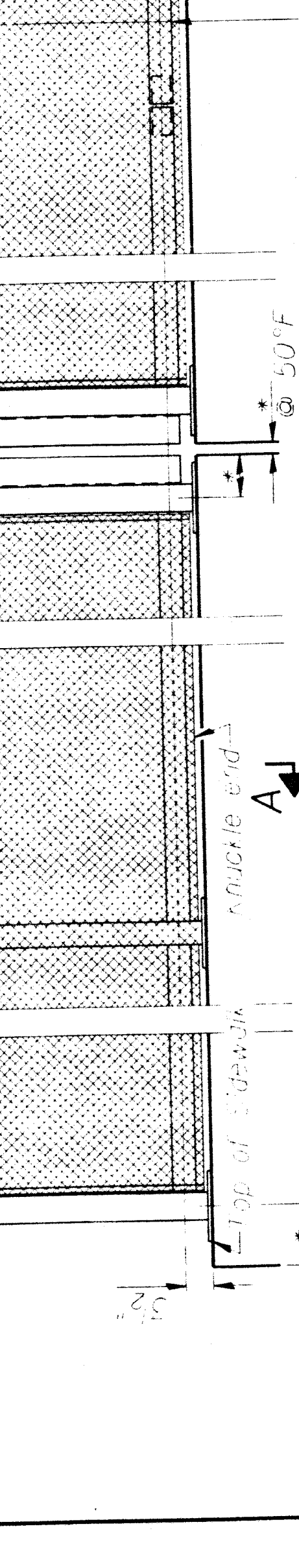
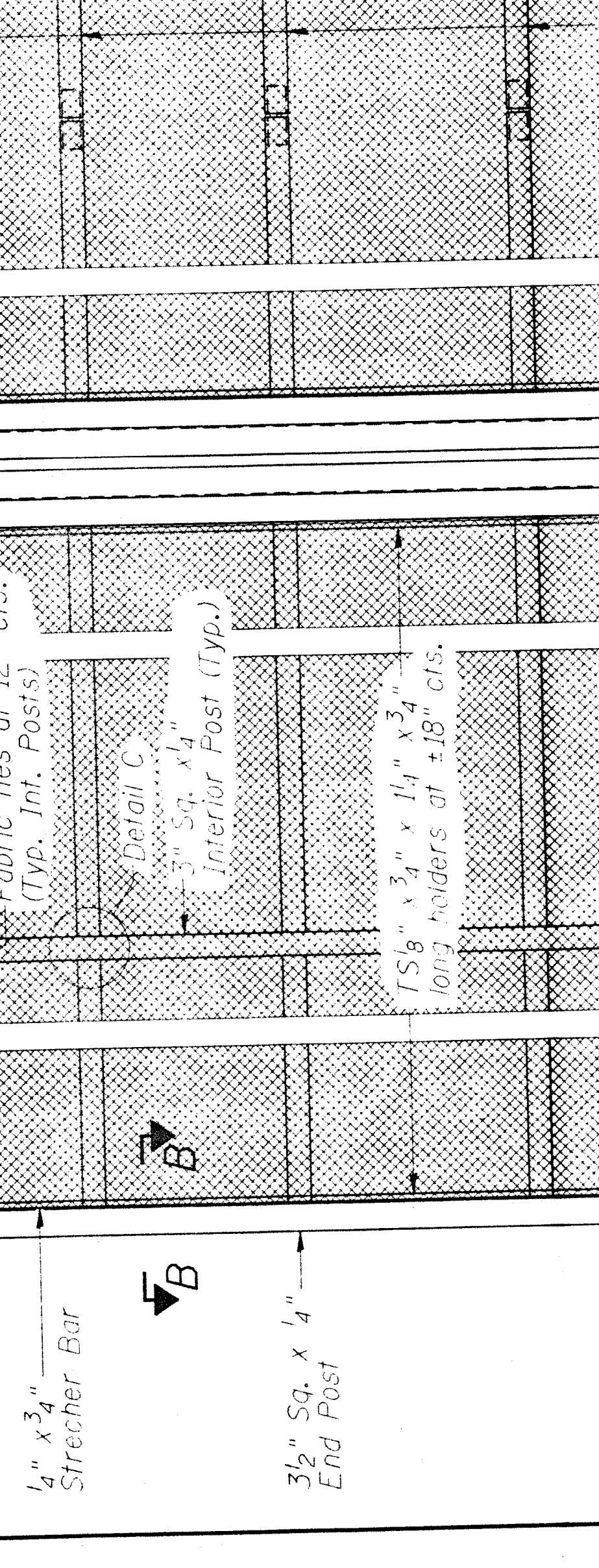
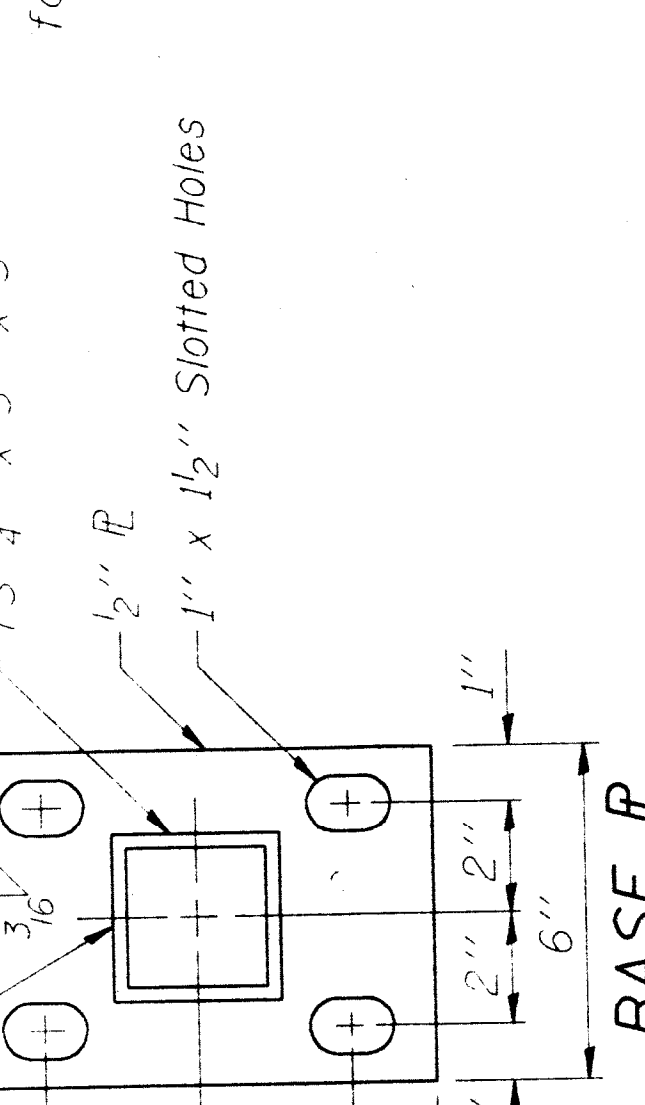
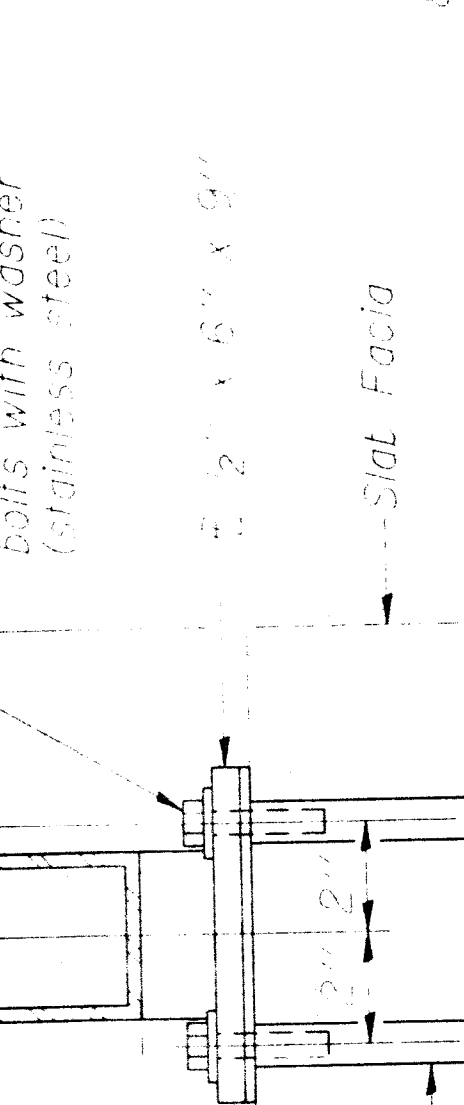
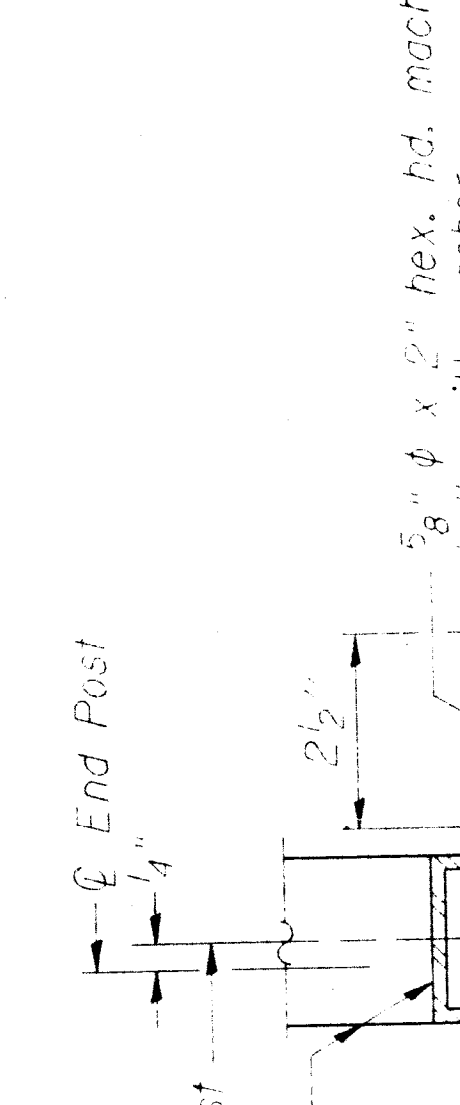
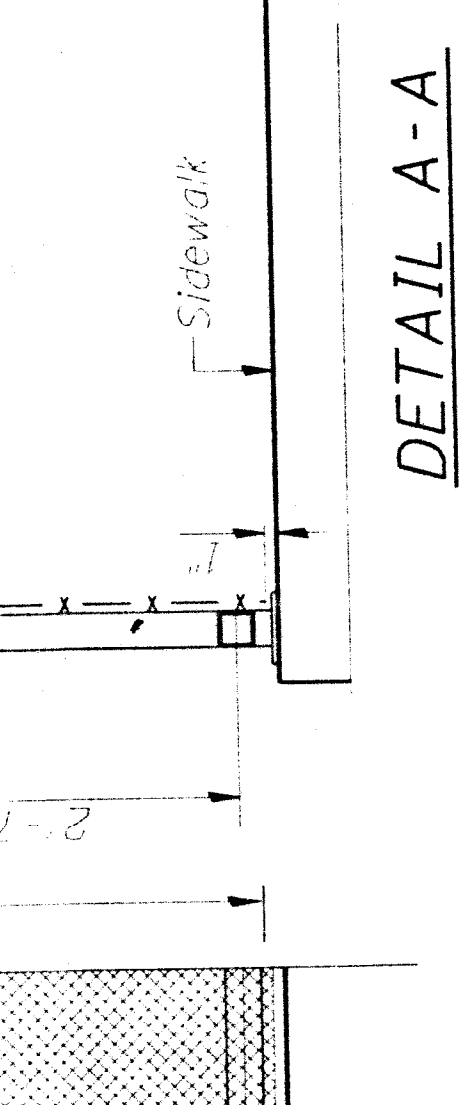
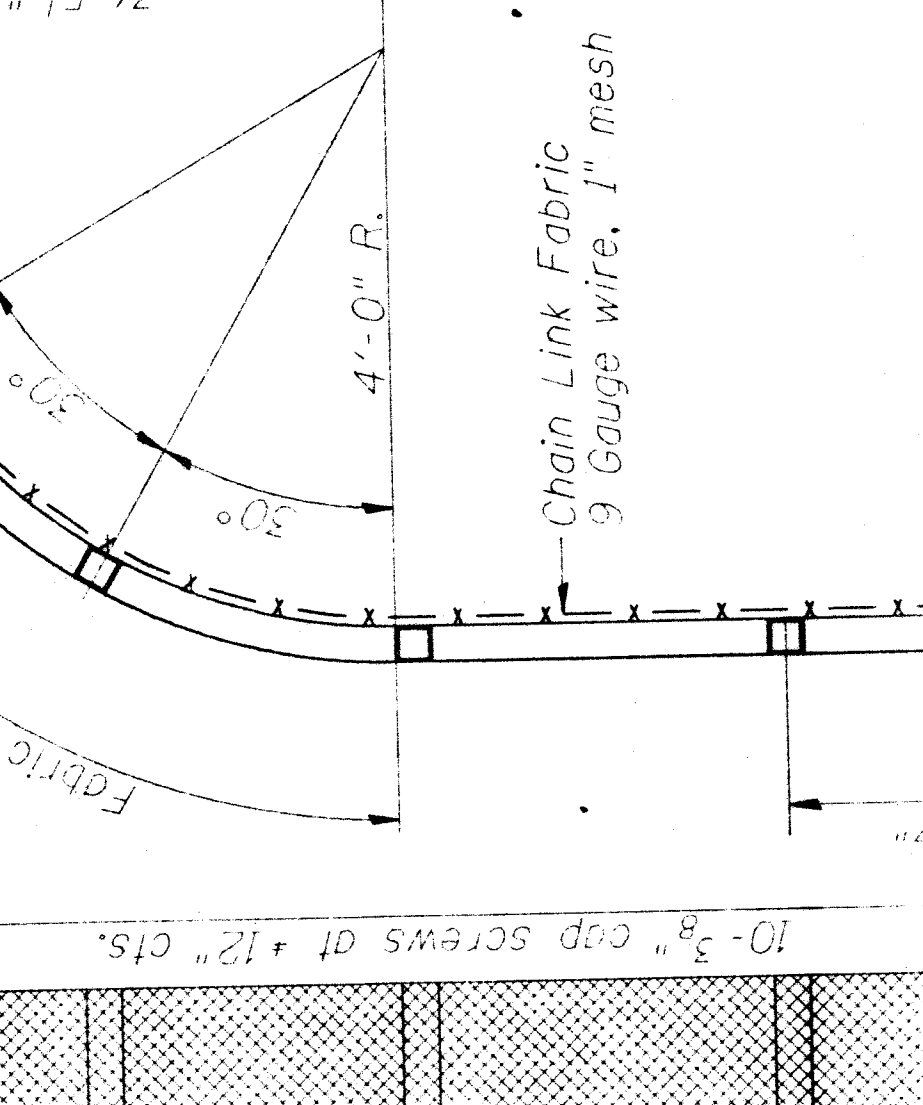
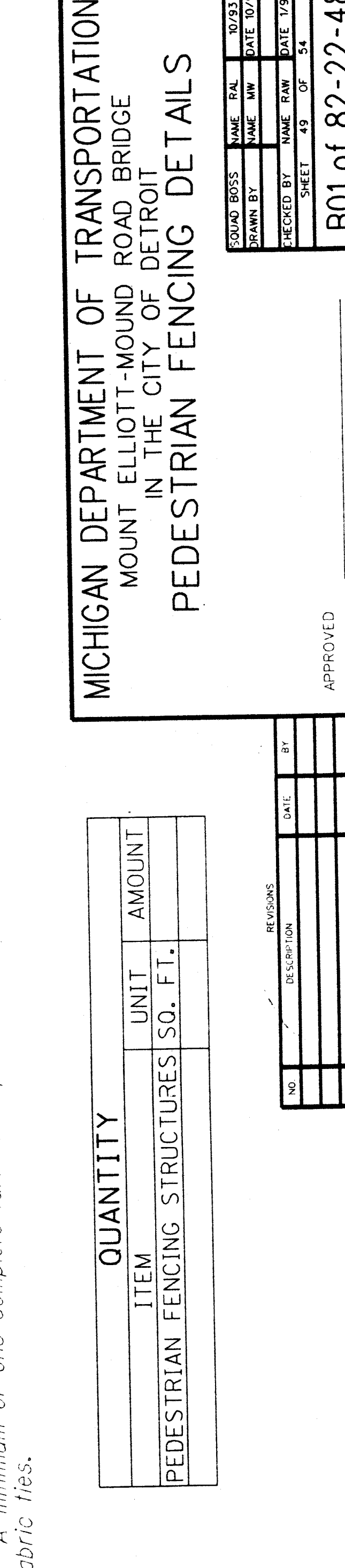
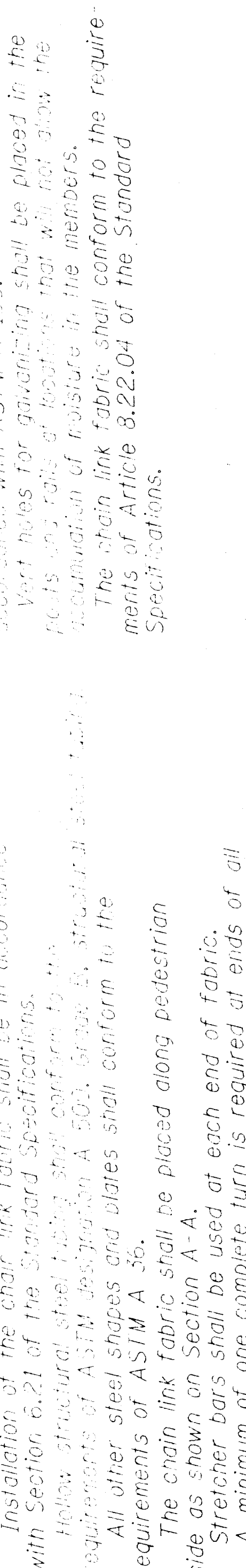
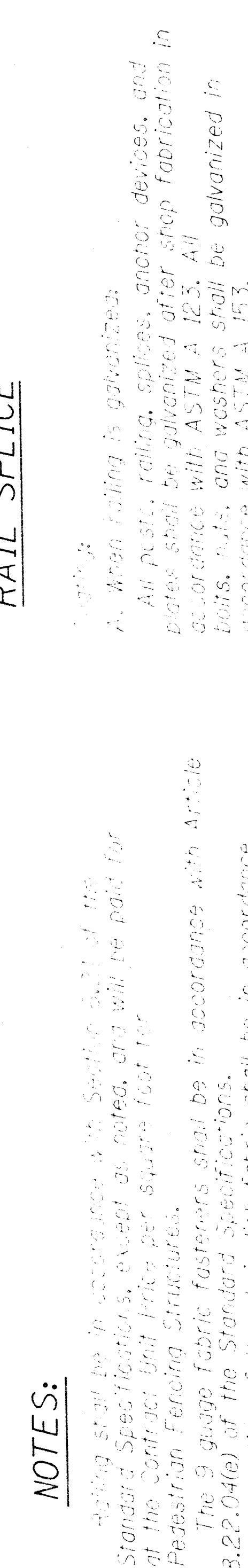
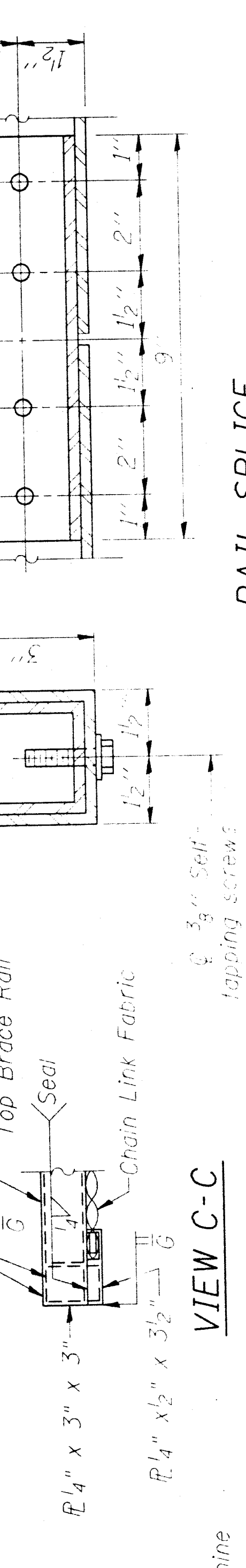
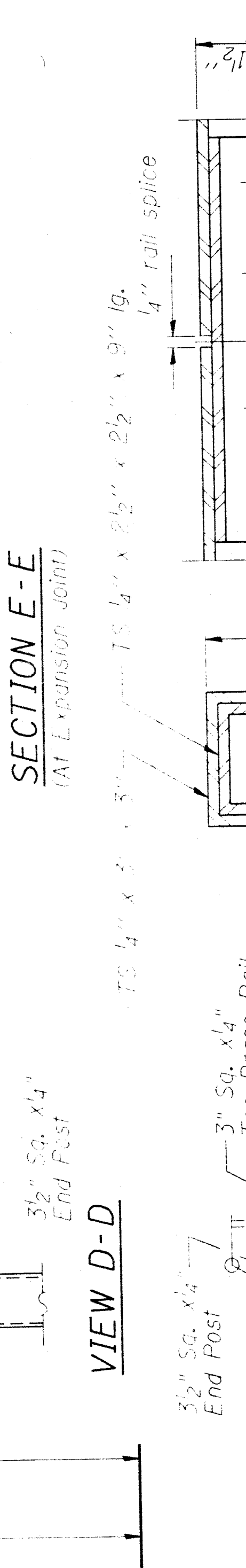
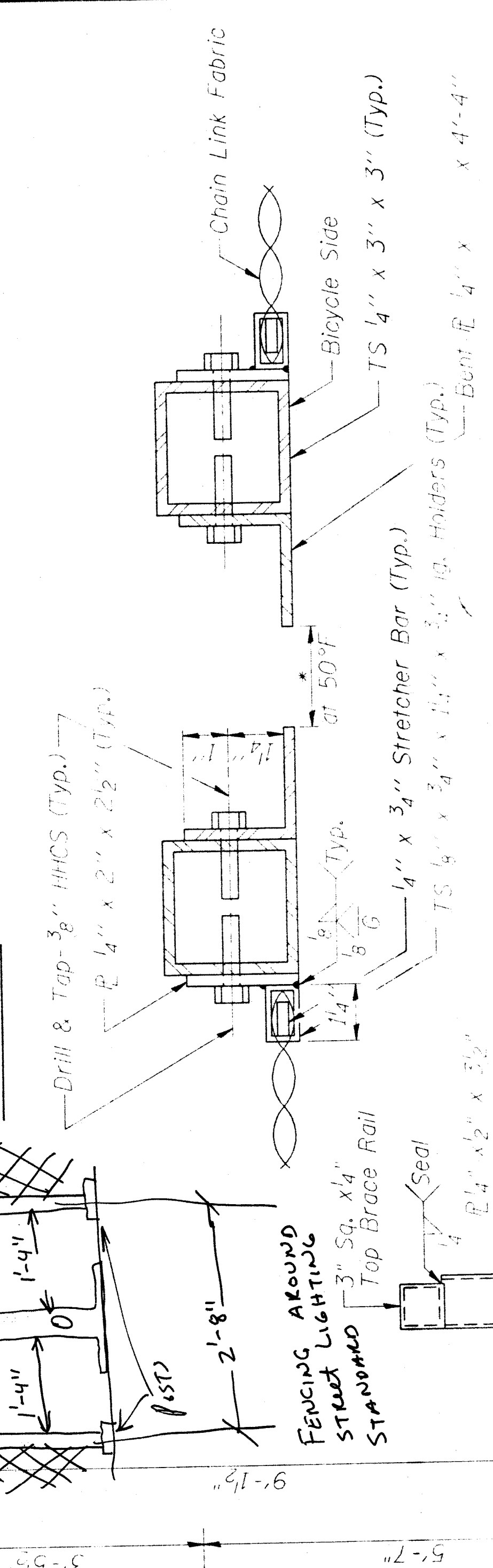
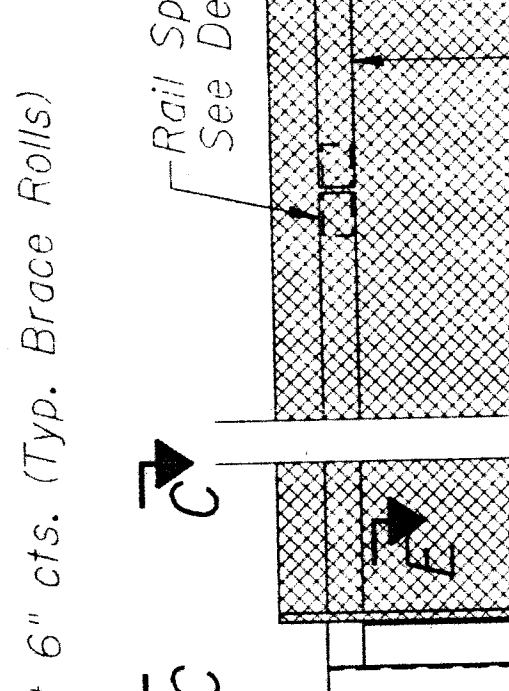
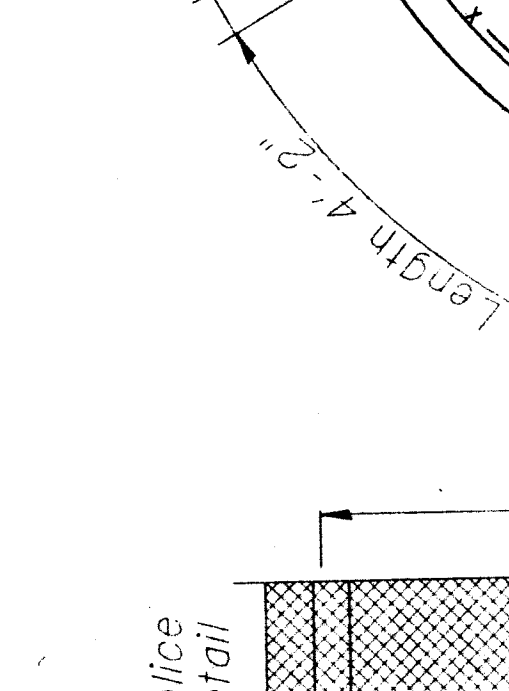
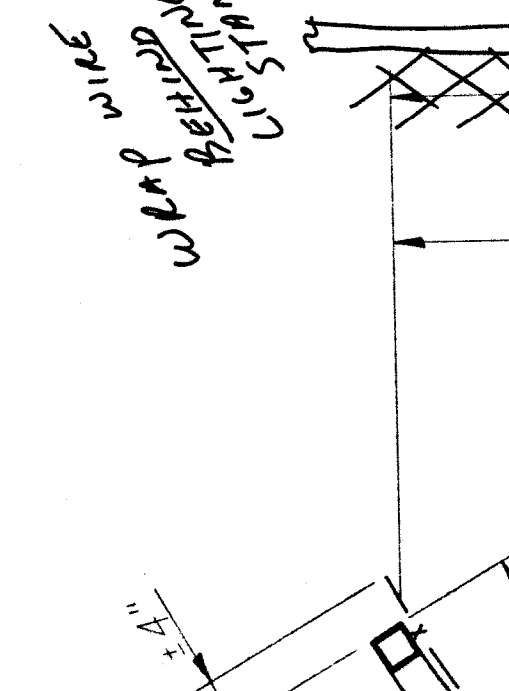
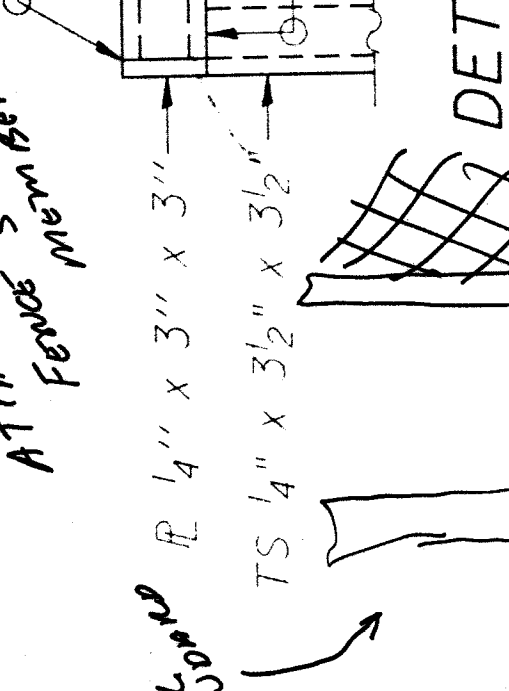
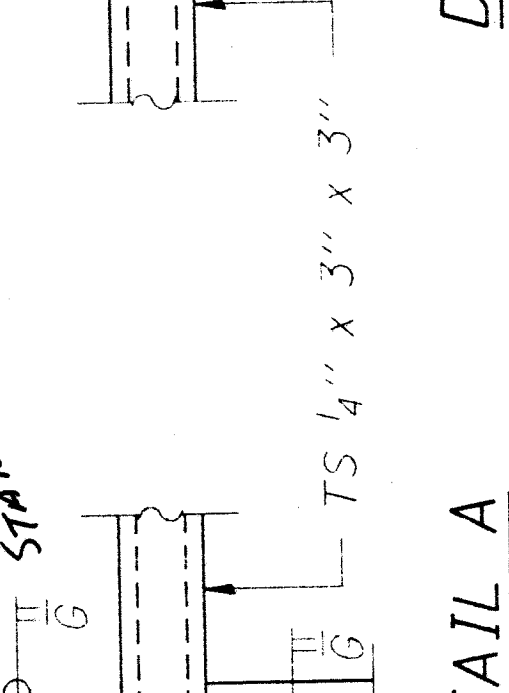
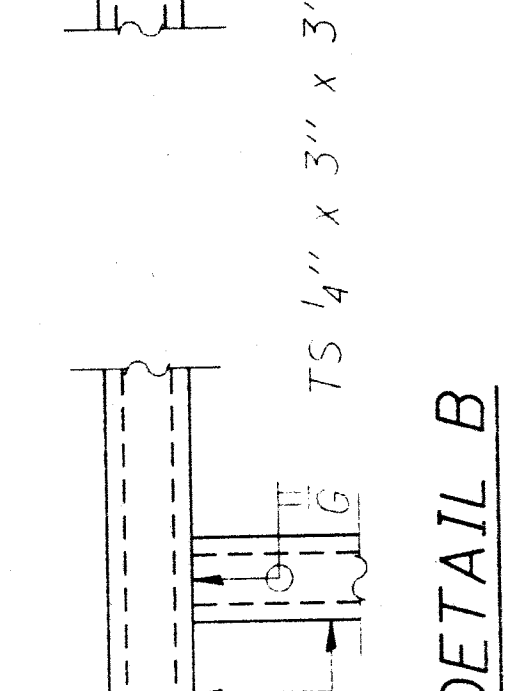
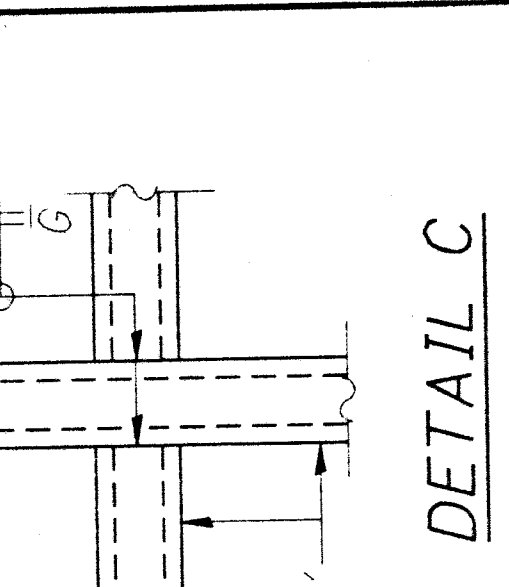
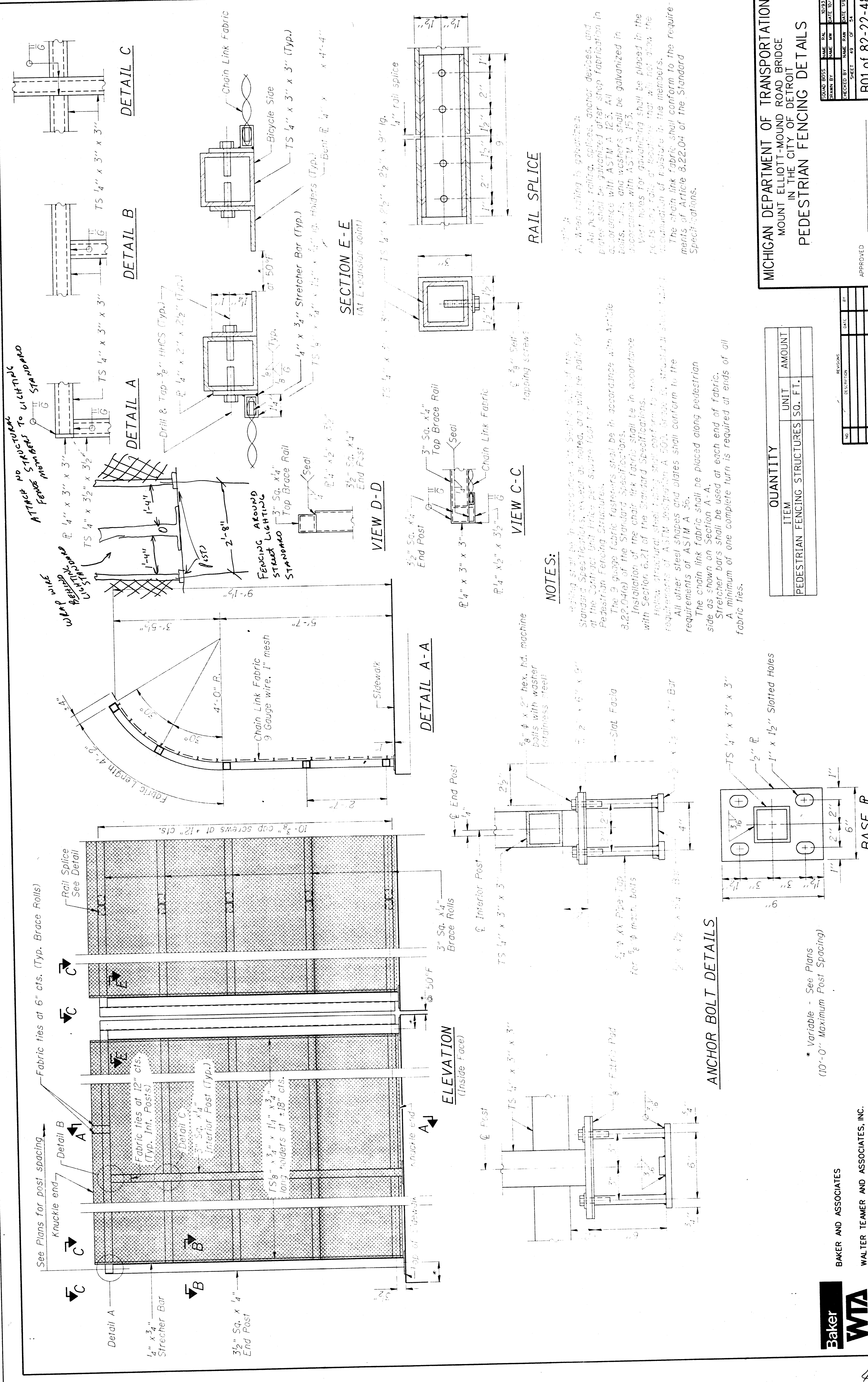

ANCHOR BOLT DETAILS

ANCHOR BOLT DETAILS

* Variable - See Plans
 (10'-0" Maximum Post Spacing)

RAIL SPLICE

RAIL SPLICE

RAIL SPLICE

NOTES:

1. When railing is galvanized:
 All posts, railings, splices, anchor devices, and plates shall be galvanized after shop fabrication in accordance with ASTM A 123. All bolts, nuts, and washers shall be galvanized in accordance with ASTM A 153.
 2. Vertical holes for galvanizing shall be placed in the rails and rail splices so that they will not show the accumulation of moisture in the members.
 3. The chain link fabric shall conform to the requirements of Article 8.22.04 of the Standard Specifications.

DETAILS

DETAILS

DETAILS

MICHIGAN DEPARTMENT OF TRANSPORTATION
 MOUNT ELLIOTT-MOUND ROAD BRIDGE
 IN THE CITY OF DETROIT
PEDESTRIAN FENCING DETAILS

QUANTITY	ITEM	UNIT	AMOUNT
	PEDESTRIAN FENCING STRUCTURES	SO. FT.	

NO.	REVISIONS	DATE	BY

APPROVED
 DESIGN SUPERVISING ENGINEER
B01 of 82-22-48

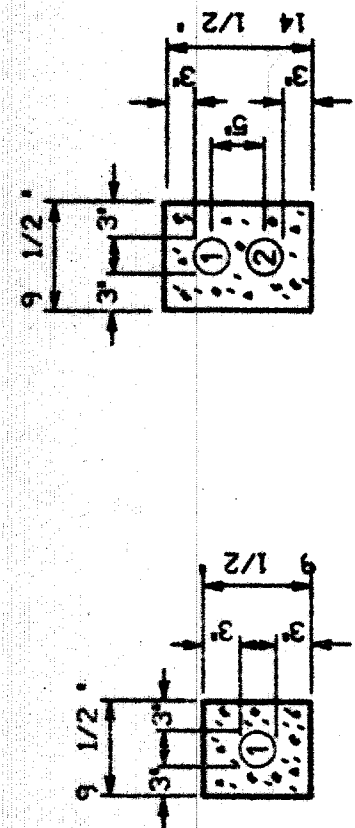

1-2 CONDUIT

2-2 CONDUITS

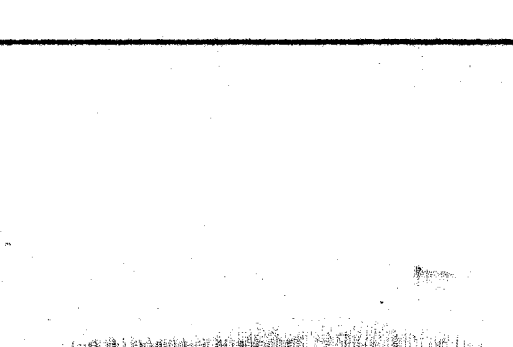
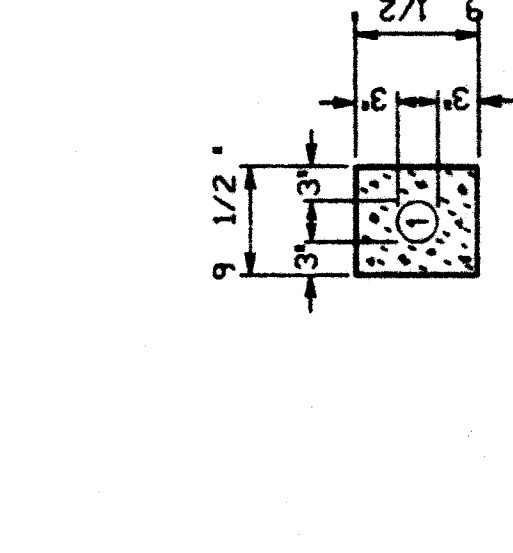
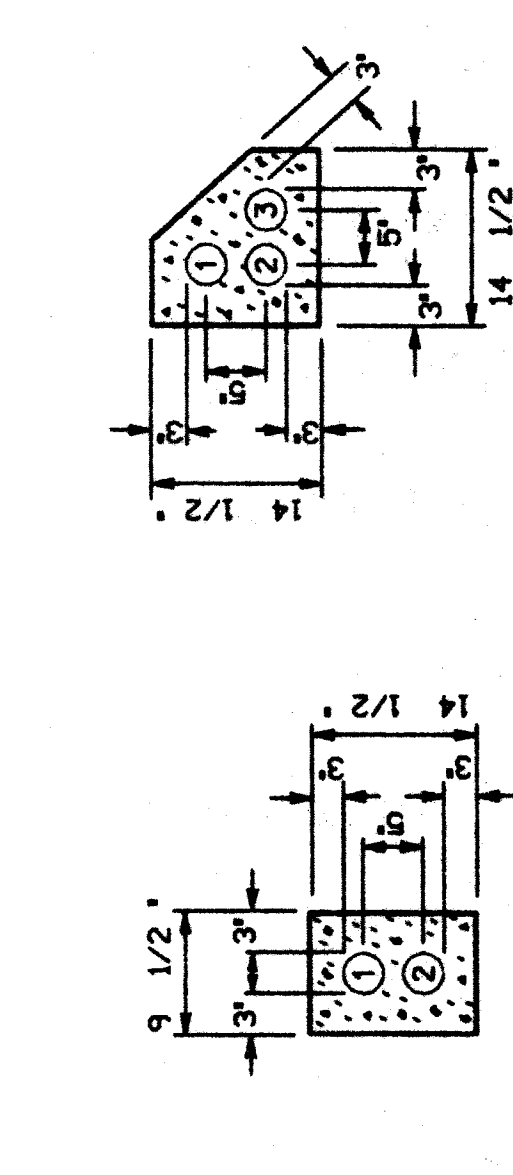
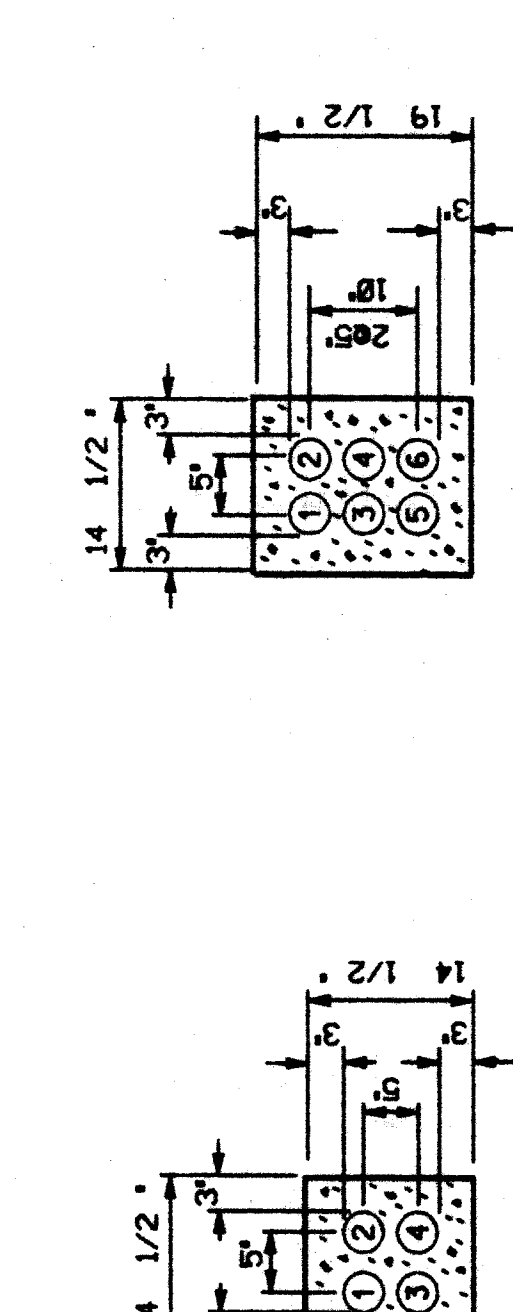

4-3 CONDUITS

6-3 CONDUITS

3-3 CONDUITS

2-3 CONDUITS

1-3 CONDUIT

2-4 CONDUITS

3-4 CONDUITS

4-4 CONDUITS

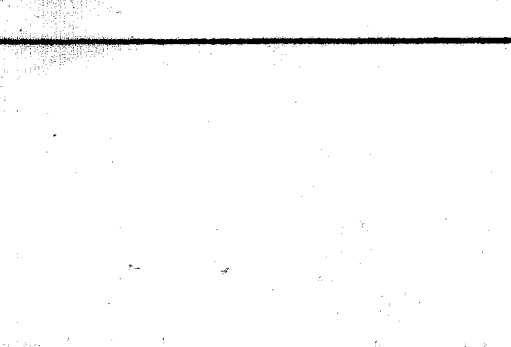
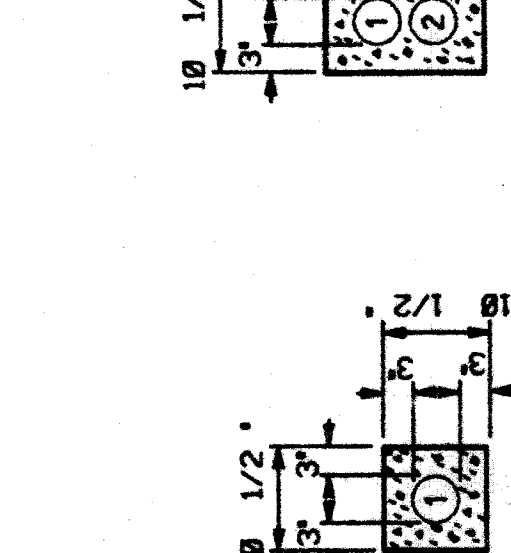
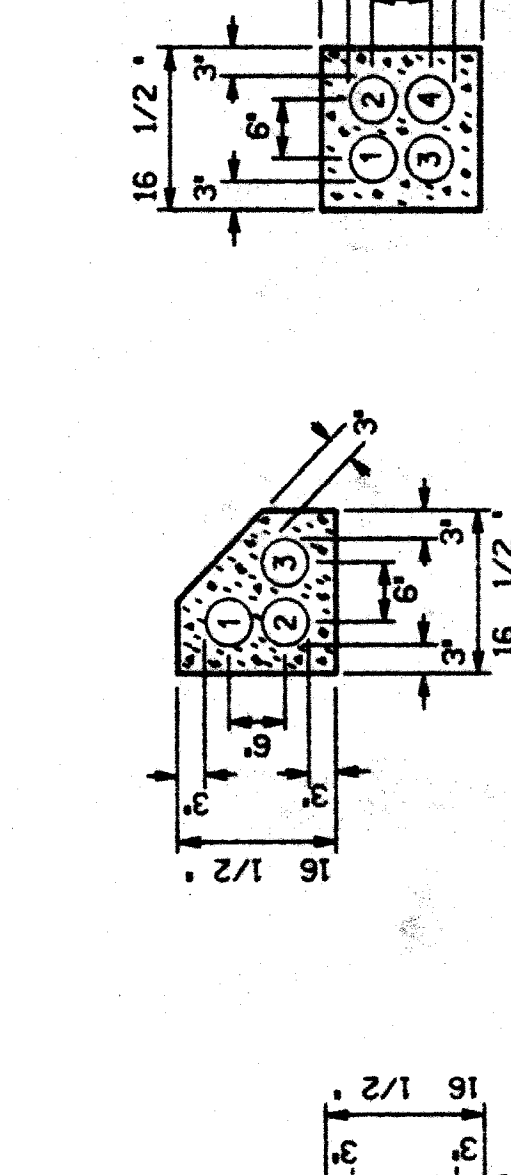
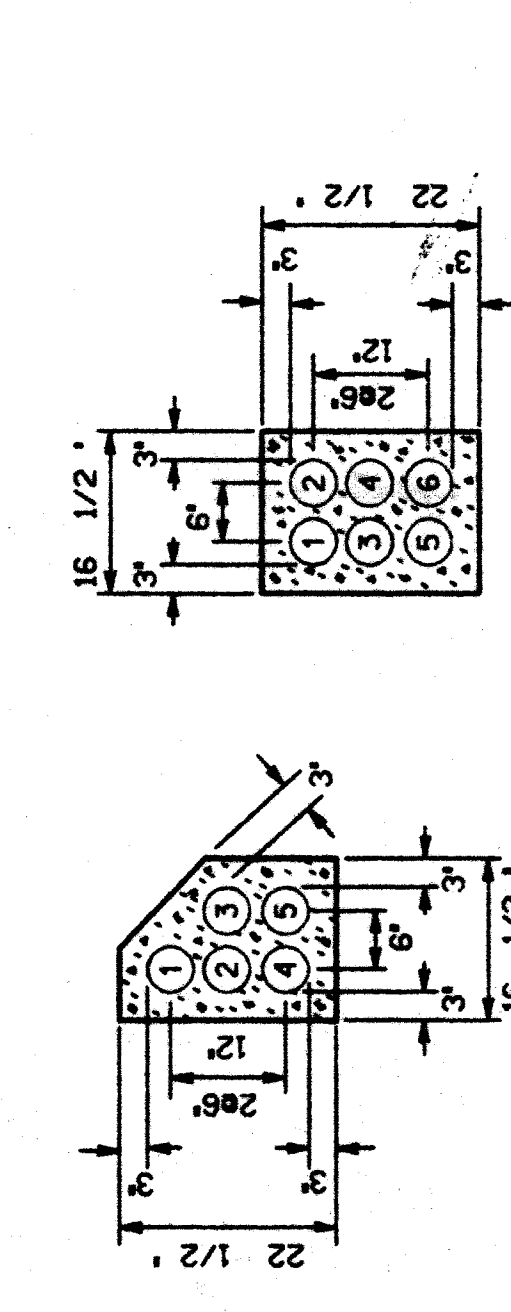

8-4 CONDUITS

9-4 CONDUITS

5-4 CONDUITS

6-4 CONDUITS

1-4 CONDUITS

2-4 CONDUITS

3-4 CONDUITS

4-4 CONDUITS

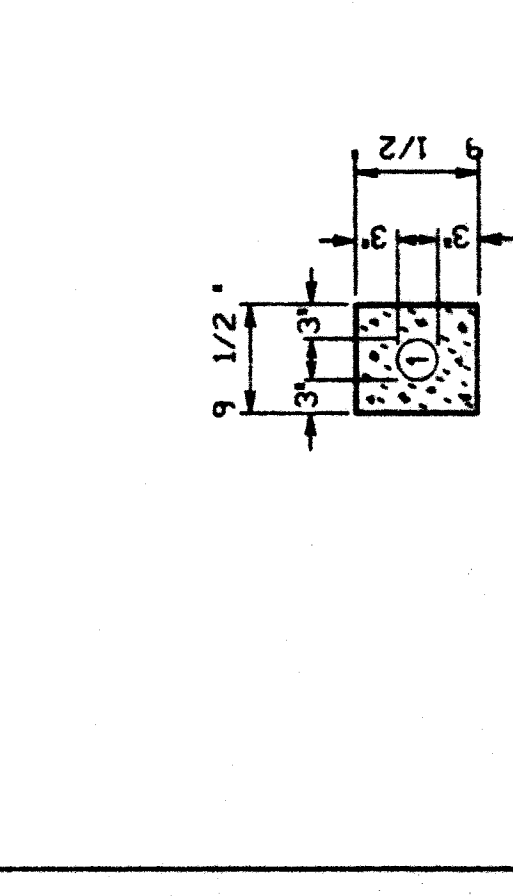
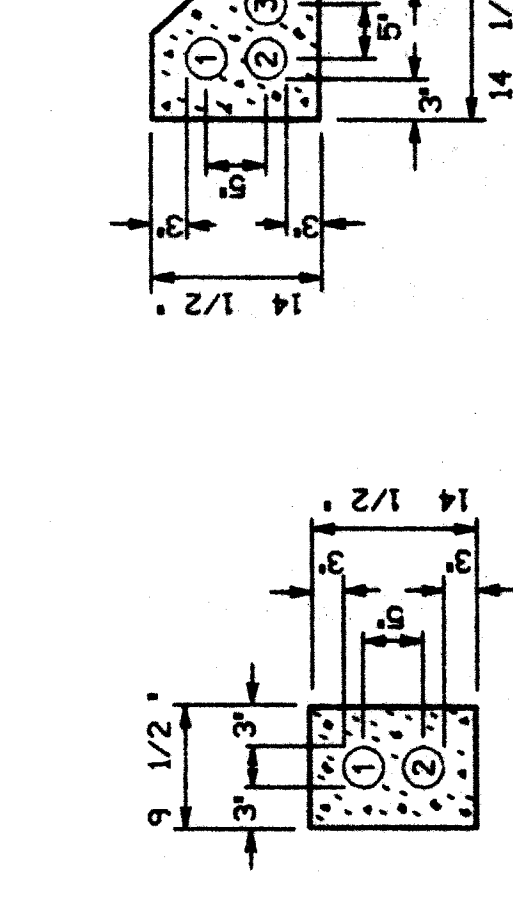
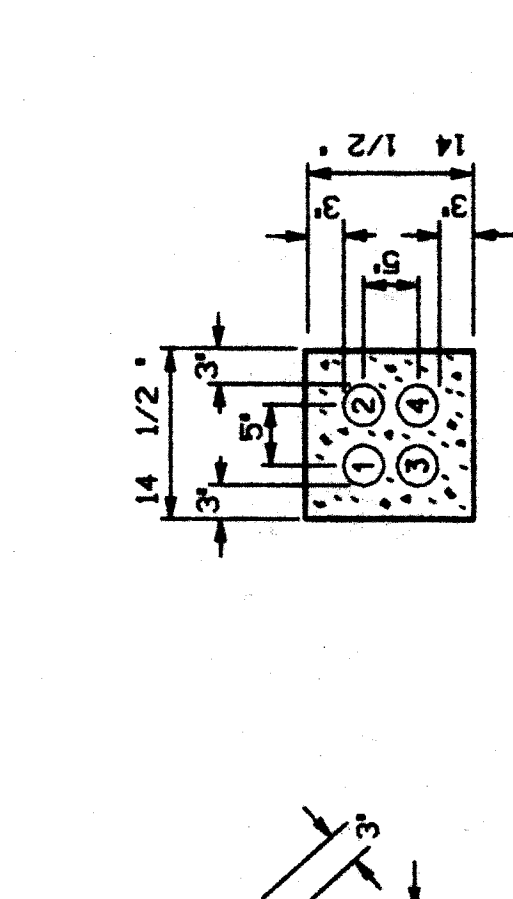
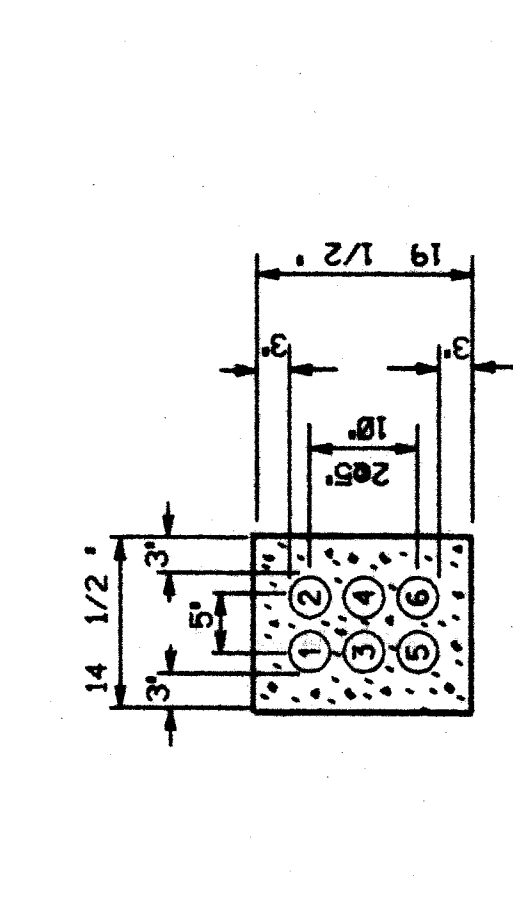
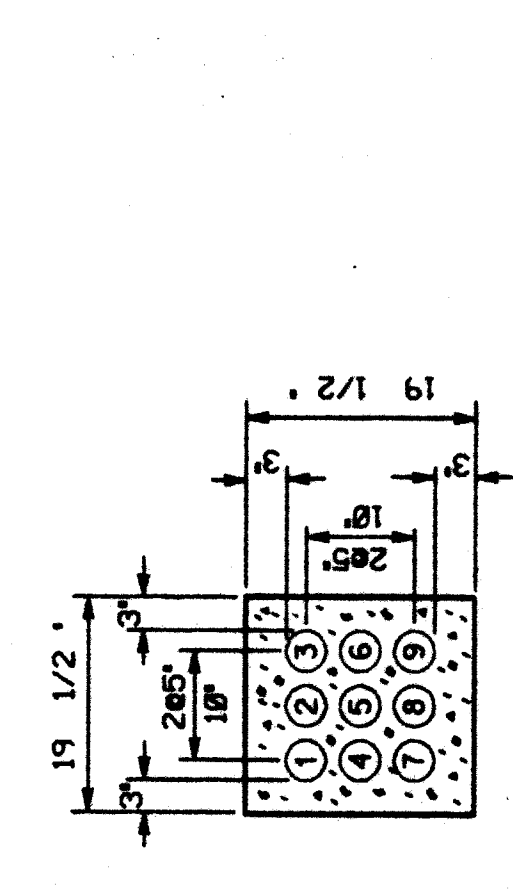
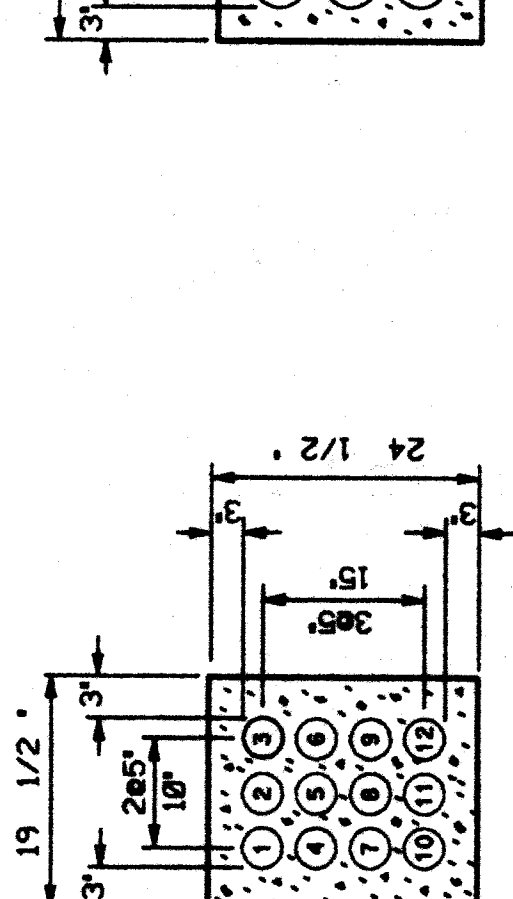

12-3 CONDUITS

9-3 CONDUITS

6-3 CONDUITS

3-3 CONDUITS

2-3 CONDUITS

1-3 CONDUIT

2-4 CONDUITS

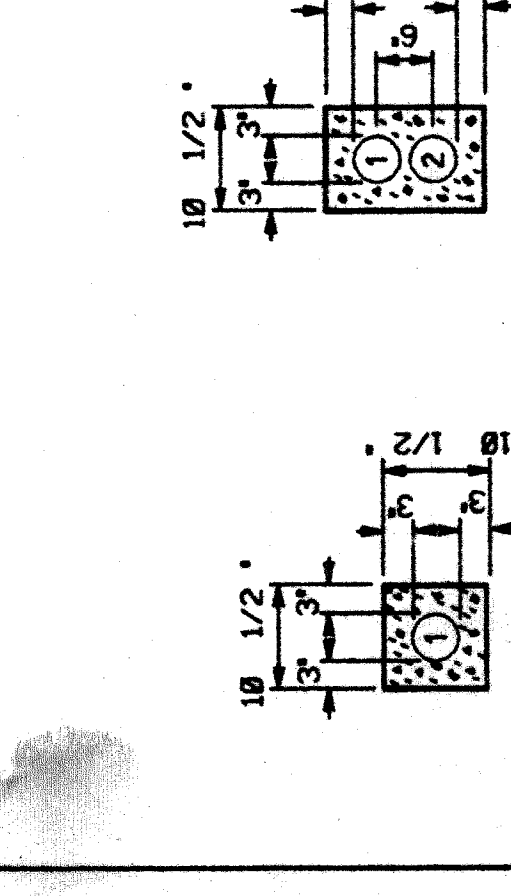
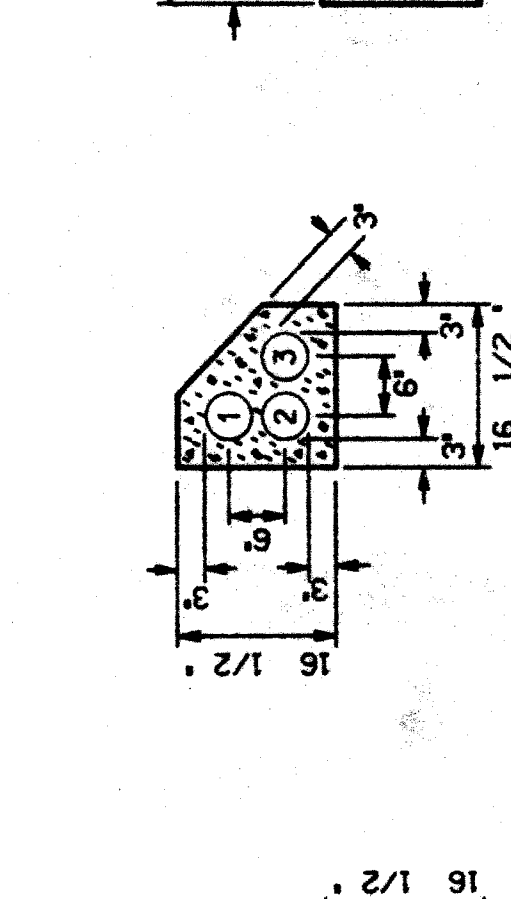
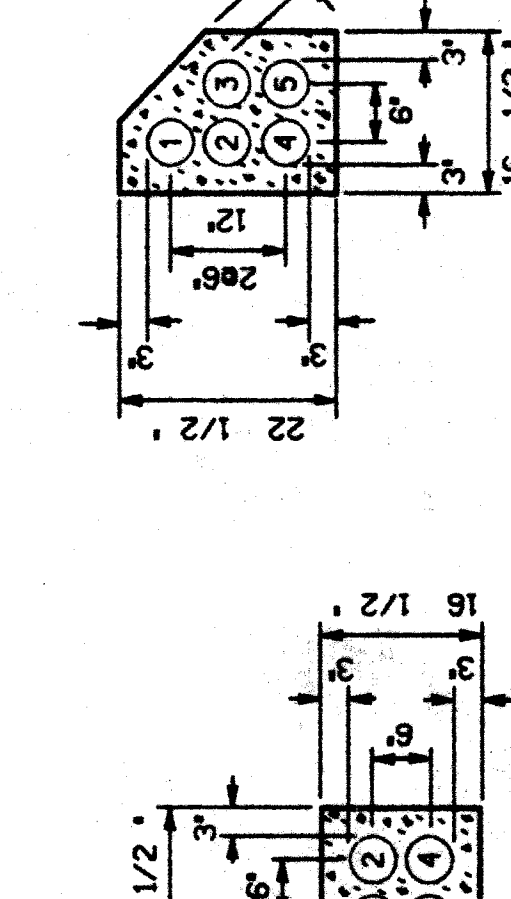
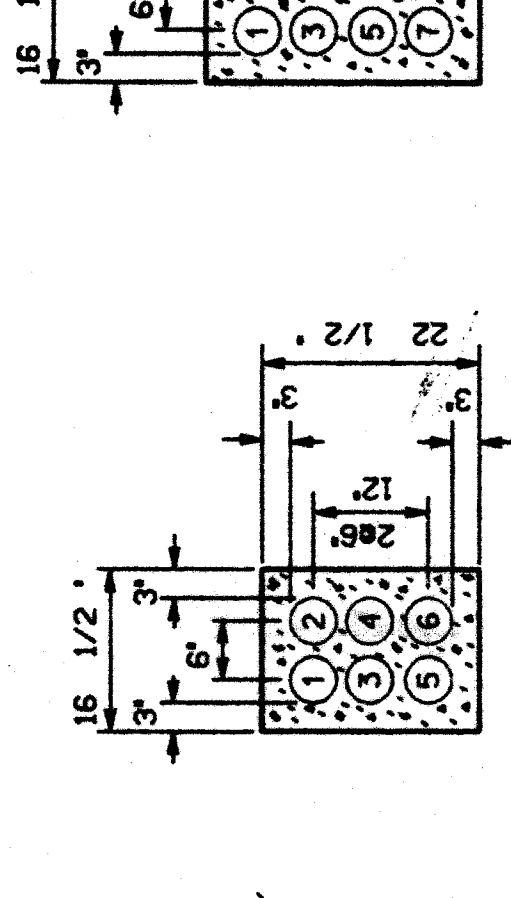
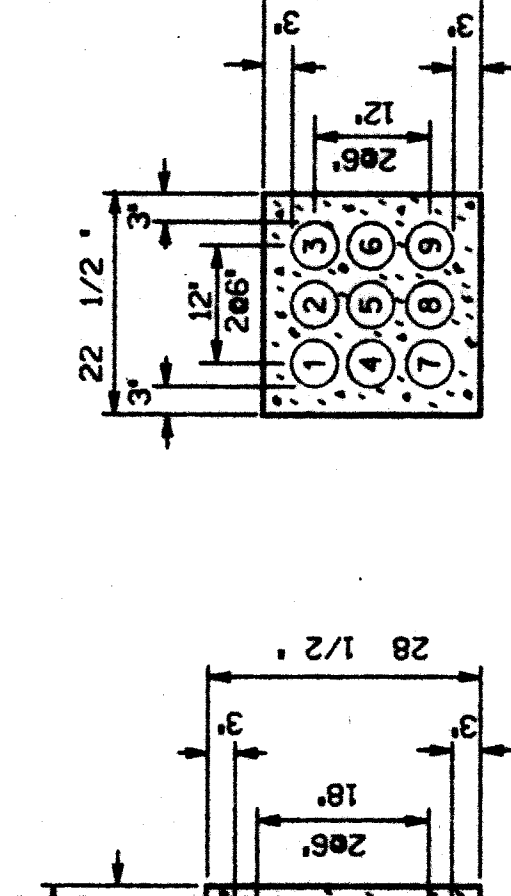
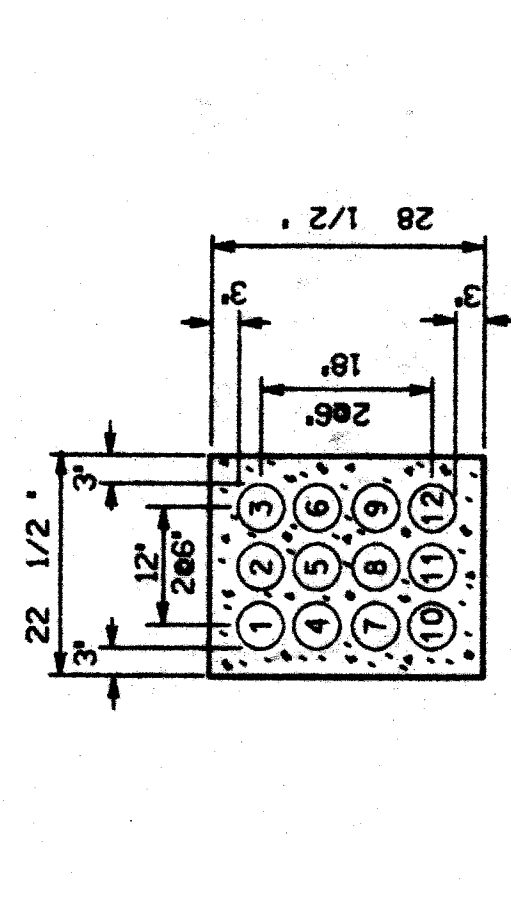

12-4 CONDUITS

9-5 CONDUITS

12-4 CONDUITS

12-4 CONDUITS

12-4 CONDUITS

12-4 CONDUITS

12-4 CONDUITS

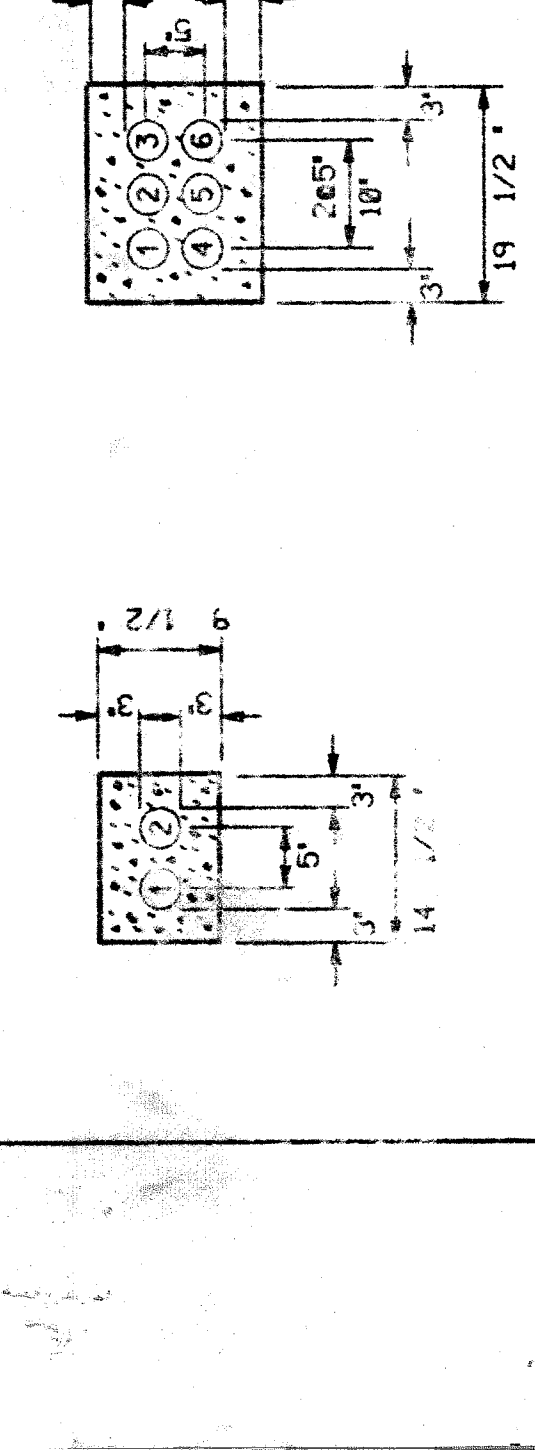
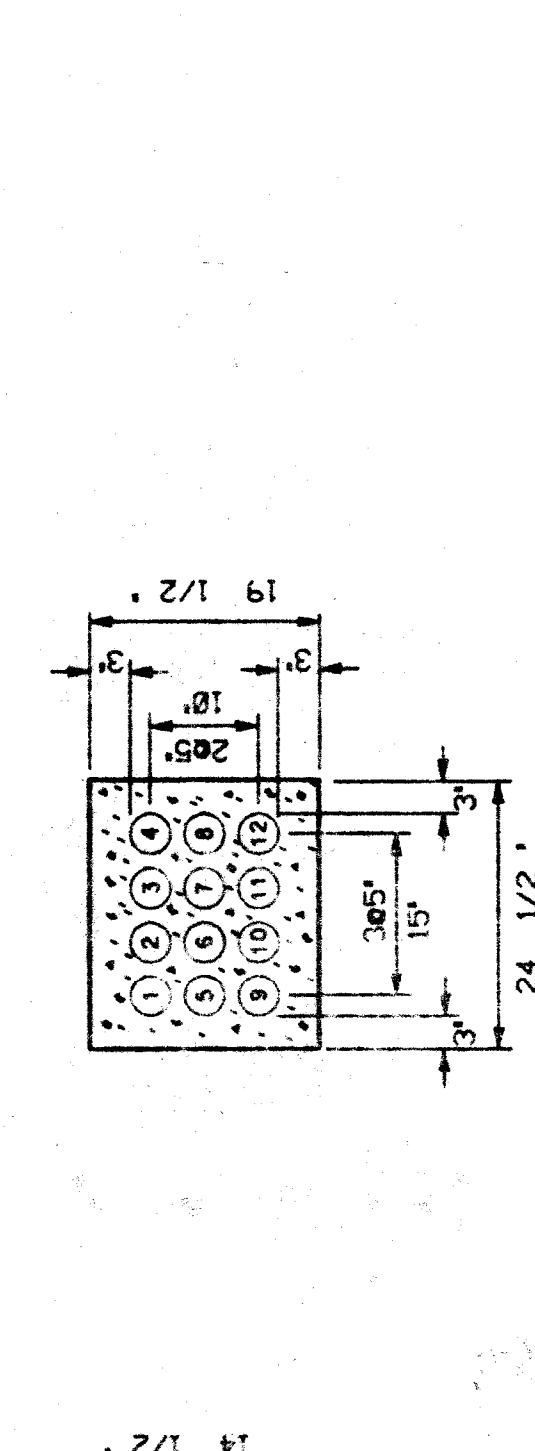
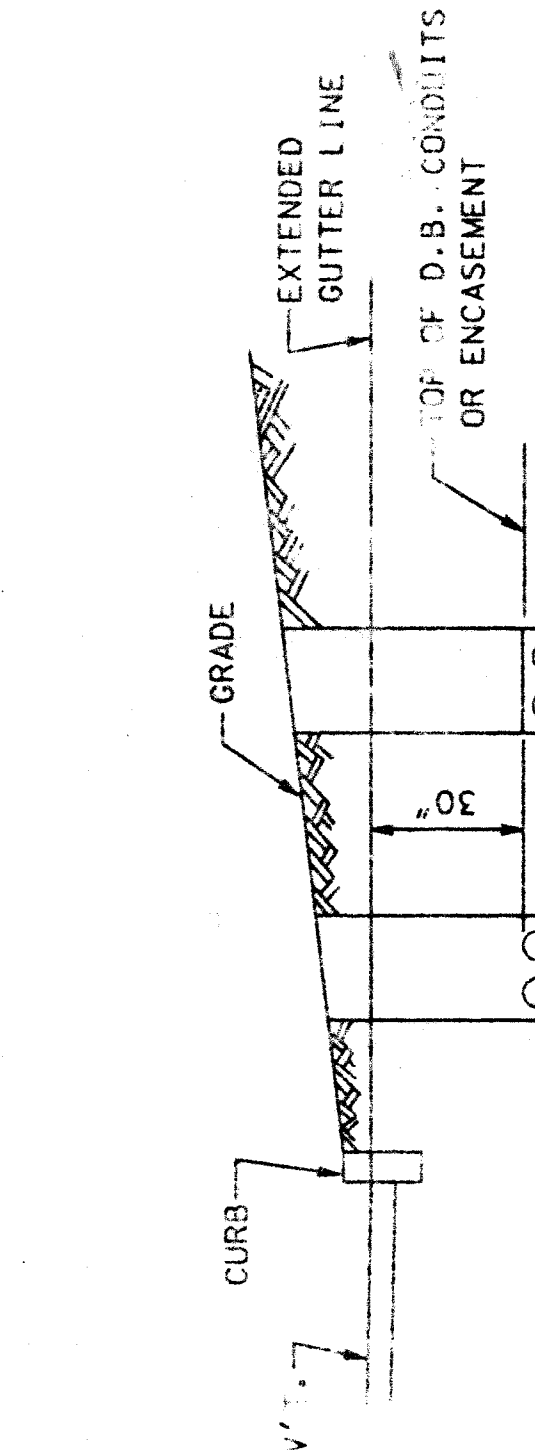

ALTERNATE ARRANGEMENT OF 3" CONDUIT
(TO SUIT FIELD CONDITIONS)
(TO BE APPROVED BY THE ENGINEER)

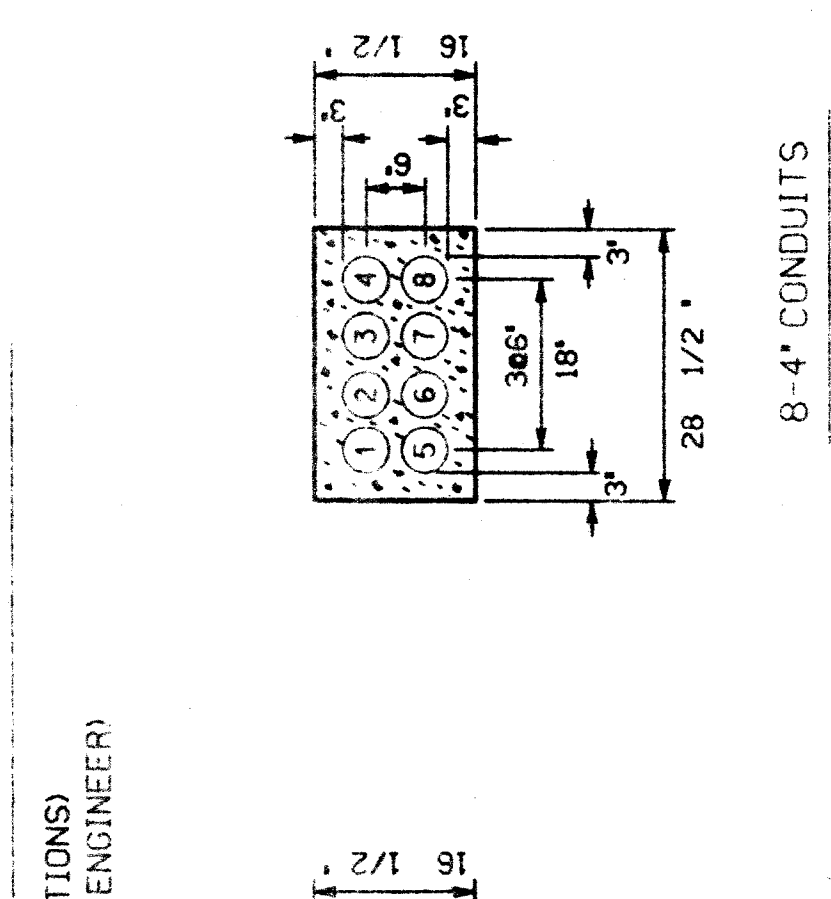

ALTERNATE ARRANGEMENT OF 4" CONDUIT
(TO SUIT FIELD CONDITIONS)
(TO BE APPROVED BY THE ENGINEER)

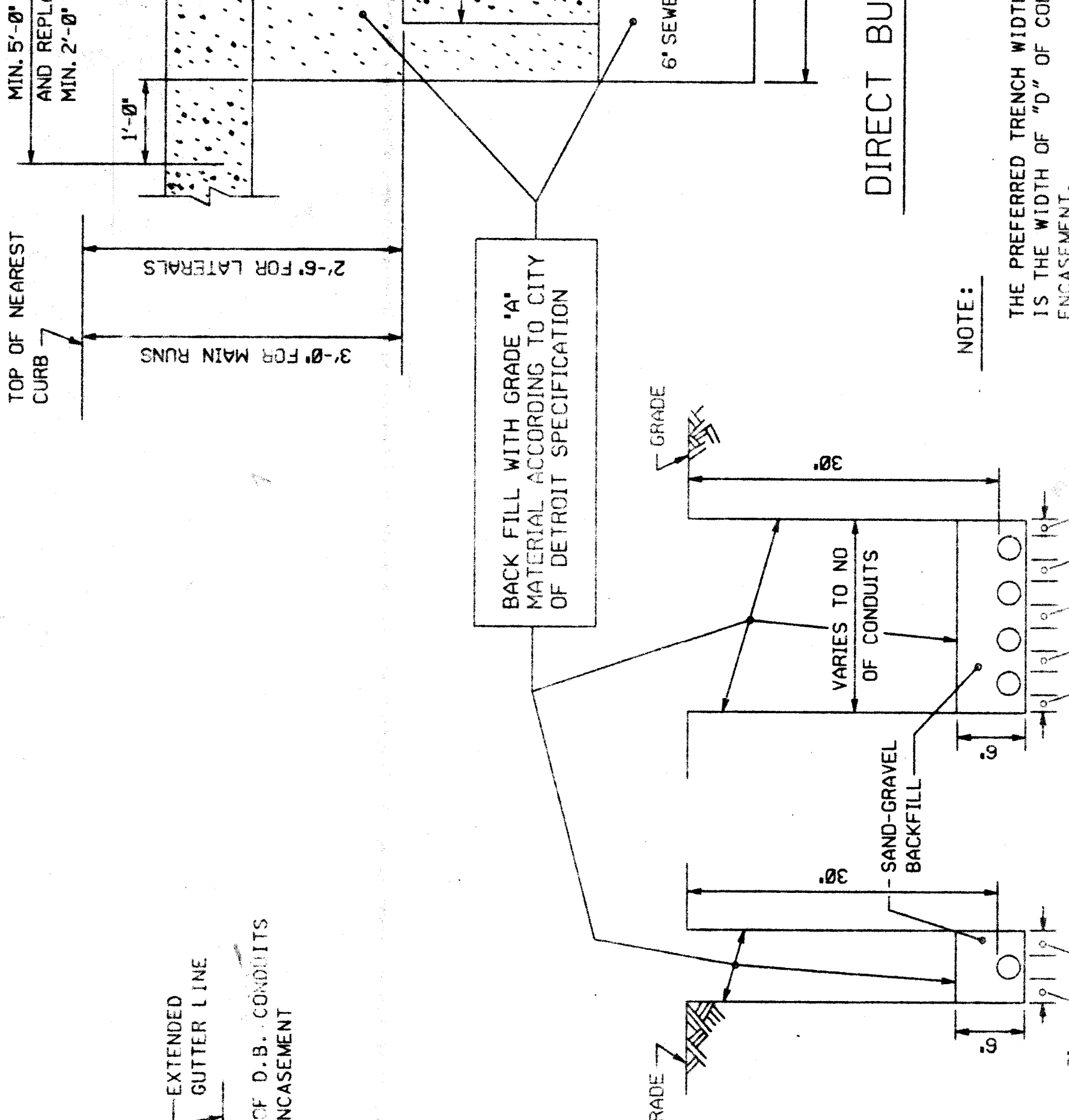
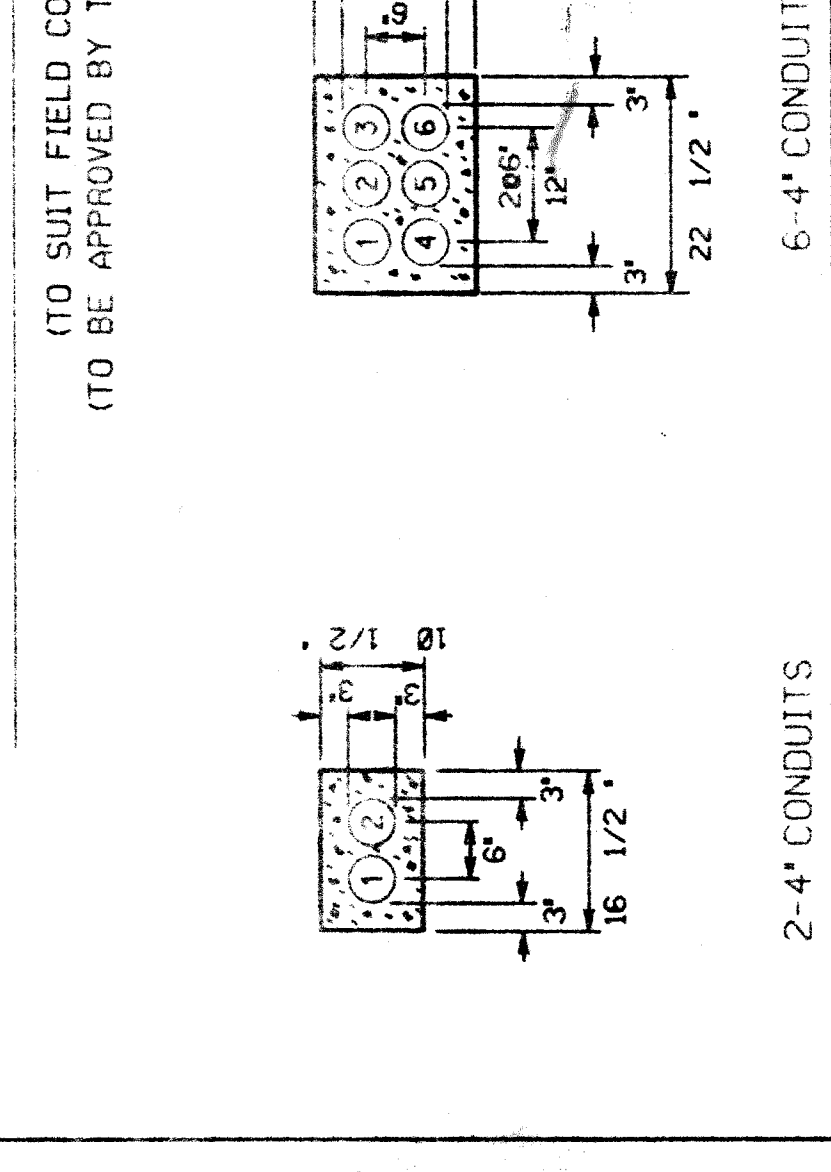

DIRECT BURIAL CONDUIT(S)

File No.	101
Sheet No.	
Date	
Checked by	PUBLIC LIGHTING DEPARTMENT
Approved by	CITY OF DETROIT
Drawn by	CEA
Checked	
Approved	
Date	
Drawn No.	16580
of	
File No.	48221
City	DETROIT, MICH.
Consulting Engineer	CONSULTING ENGINEERING ASSOCIATES INC.
Address	16580 Wyoming

DETAIL FOR JOINING CONDUIT ENCASEMENTS

DATE	DESCRIPTION	CHG. BY

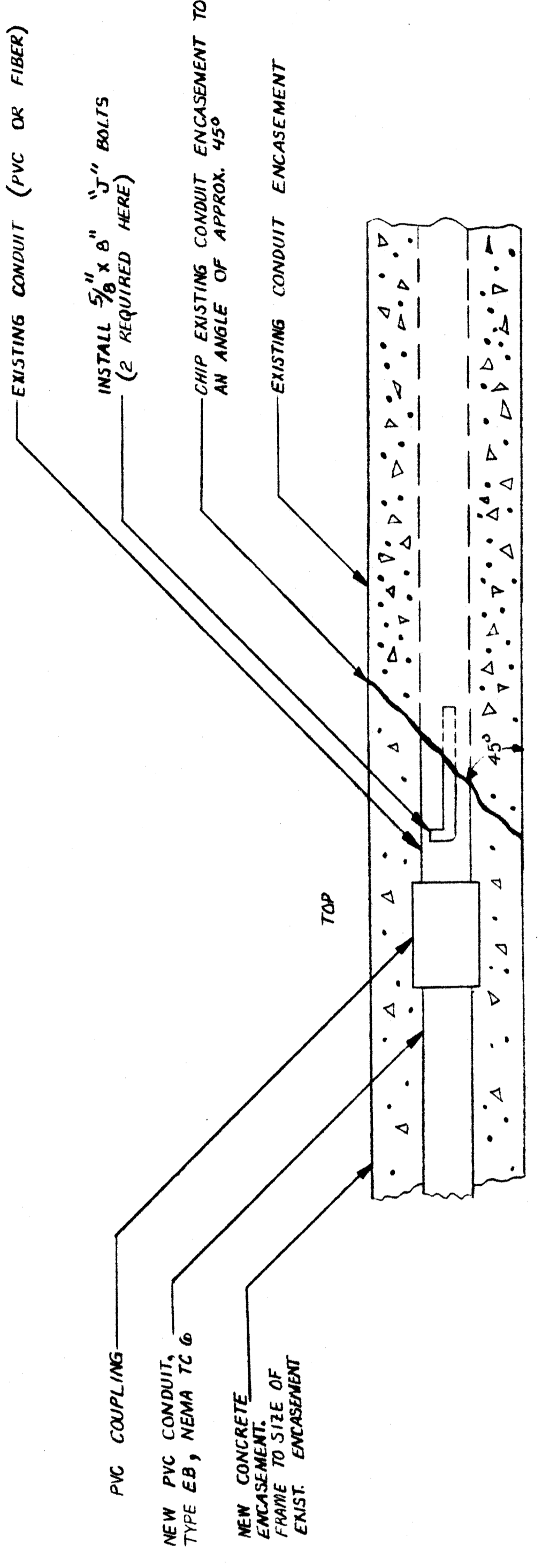

DETAIL A
(N.T.S.)
SIDE VIEW OF A SINGLE CONDUIT ENCASEMENT

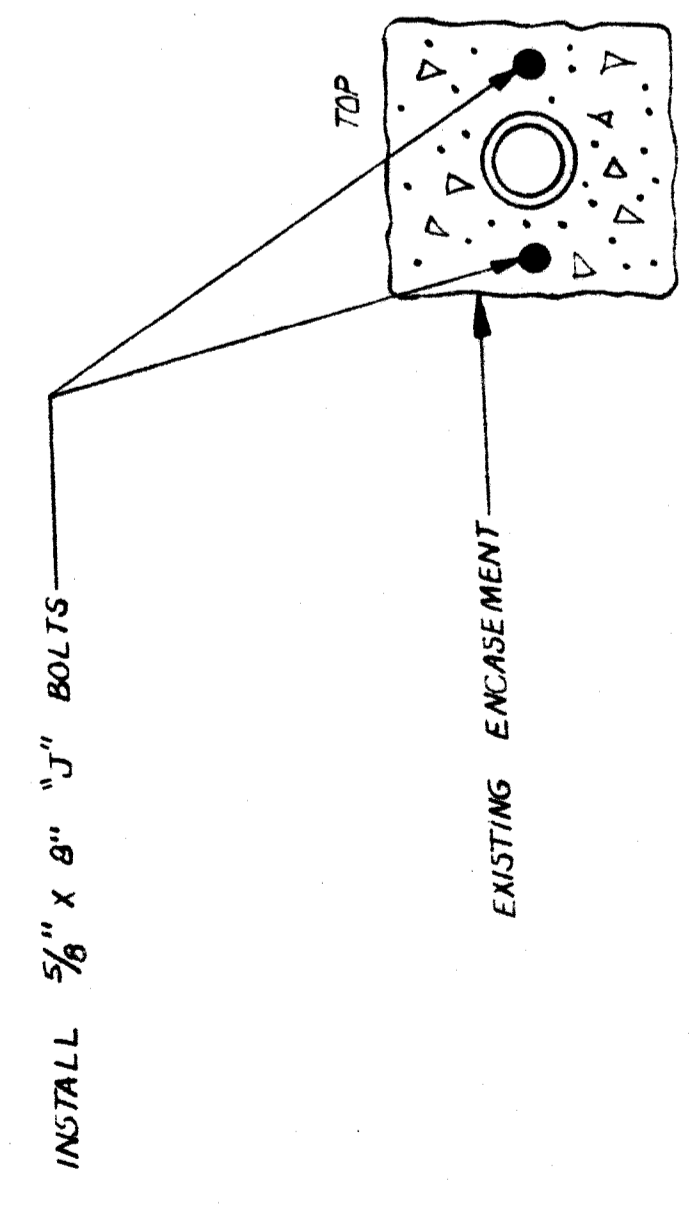

DETAIL A
(N.T.S.)
END VIEW OF CONDUIT ENCASEMENT SHOWING APPROX. LOCATION OF "J" BOLTS

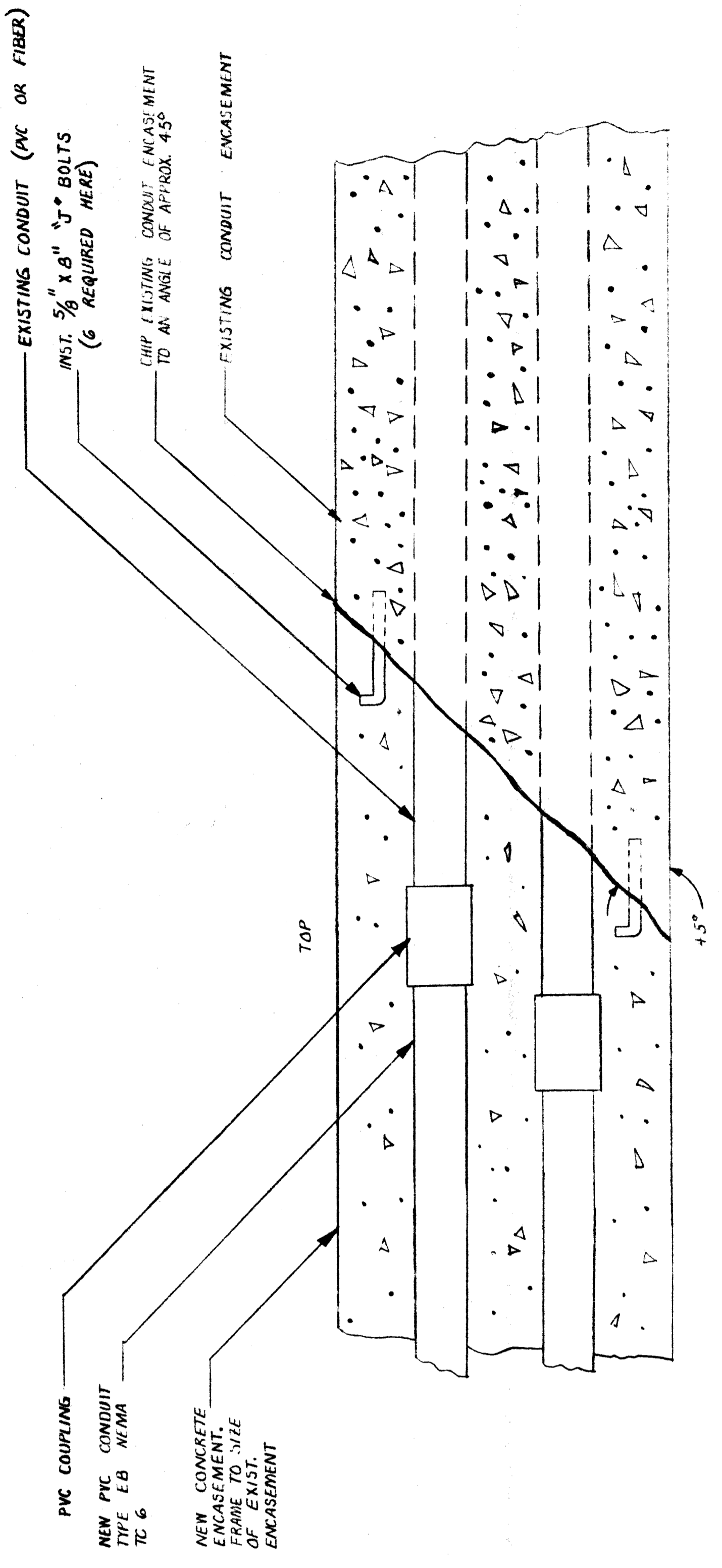

DETAIL B
(N.T.S.)
SIDE VIEW OF A MULTIPLE CONDUIT ENCASEMENT

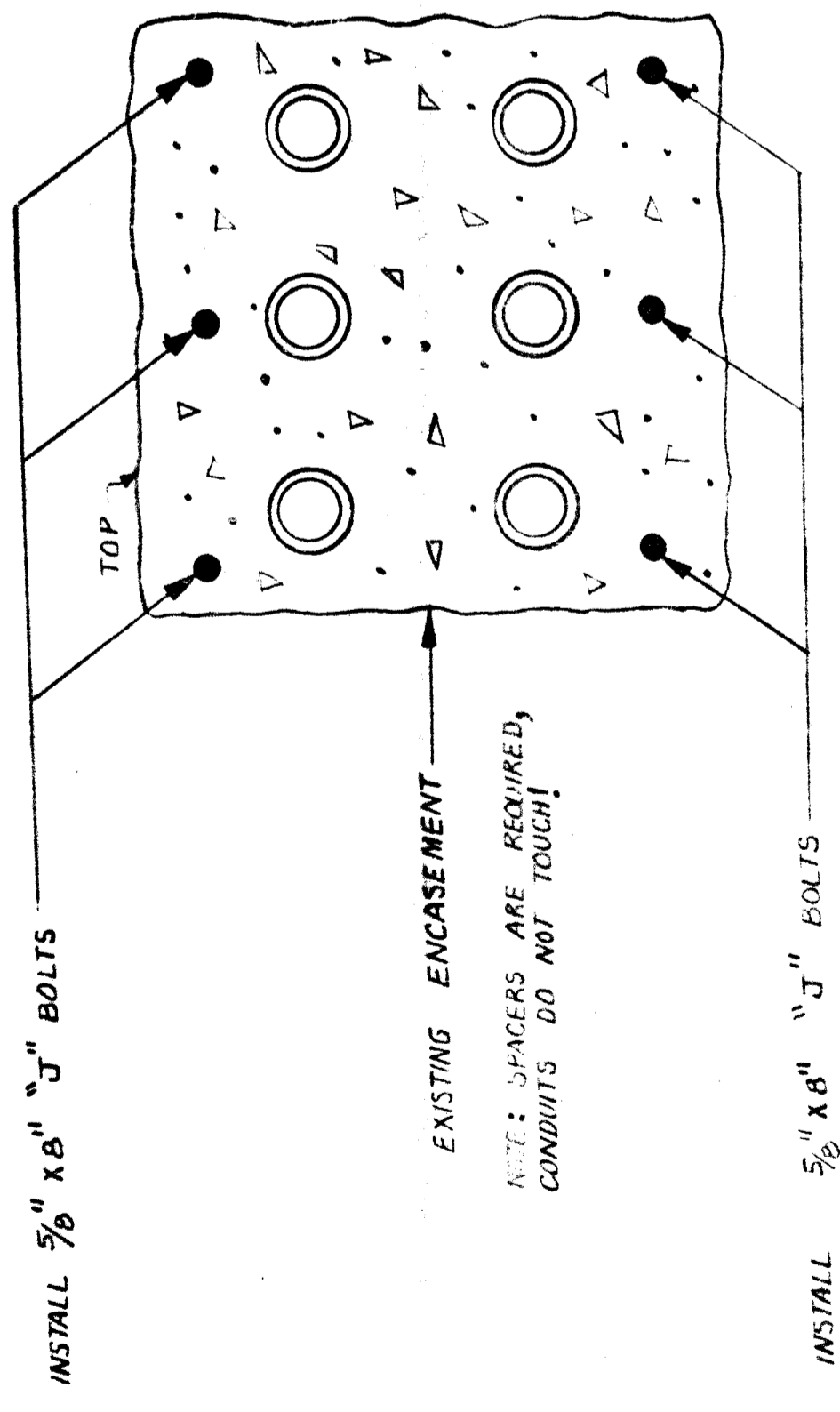

DETAIL B
(N.T.S.)
END VIEW OF CONDUIT ENCASEMENT SHOWING APPROX. LOCATION OF "J" BOLTS (6 REQUIRED)

NOTE: TO TERMINATE A NEW CONDUIT BANK FOR FUTURE EXTENSION, REFER TO E.L.D. DRAWING # 44 0308

INSTALL "HEB" FUSEHOLDER (SELECT BASED ON WIRE SIZE) WITH 10A FUSE. FUSE TO BE CAPTIVE ON LOAD (LUMINAIRE) END. INSULATE ENDS CAREFULLY.

LAMP CORDS - MINIMUM SIZE #8 AWG. STRANDED, ONE BLACK, ONE WHITE. OR IDENTIFIED CONDUCTOR IS NEUTRAL.

CORD SPLICE - USE A KEARNEY SPLIT BOLT OR A CRIMP CONNECTOR. APPLY ONE LAYER OF AQUASEAL, FOLLOWED BY TWO LAYERS 1/2 TAPE.

TRON-HEB 30A. FUSE

TAG TAP 1, TAP 2, ETC. AS PER DIAGRAM

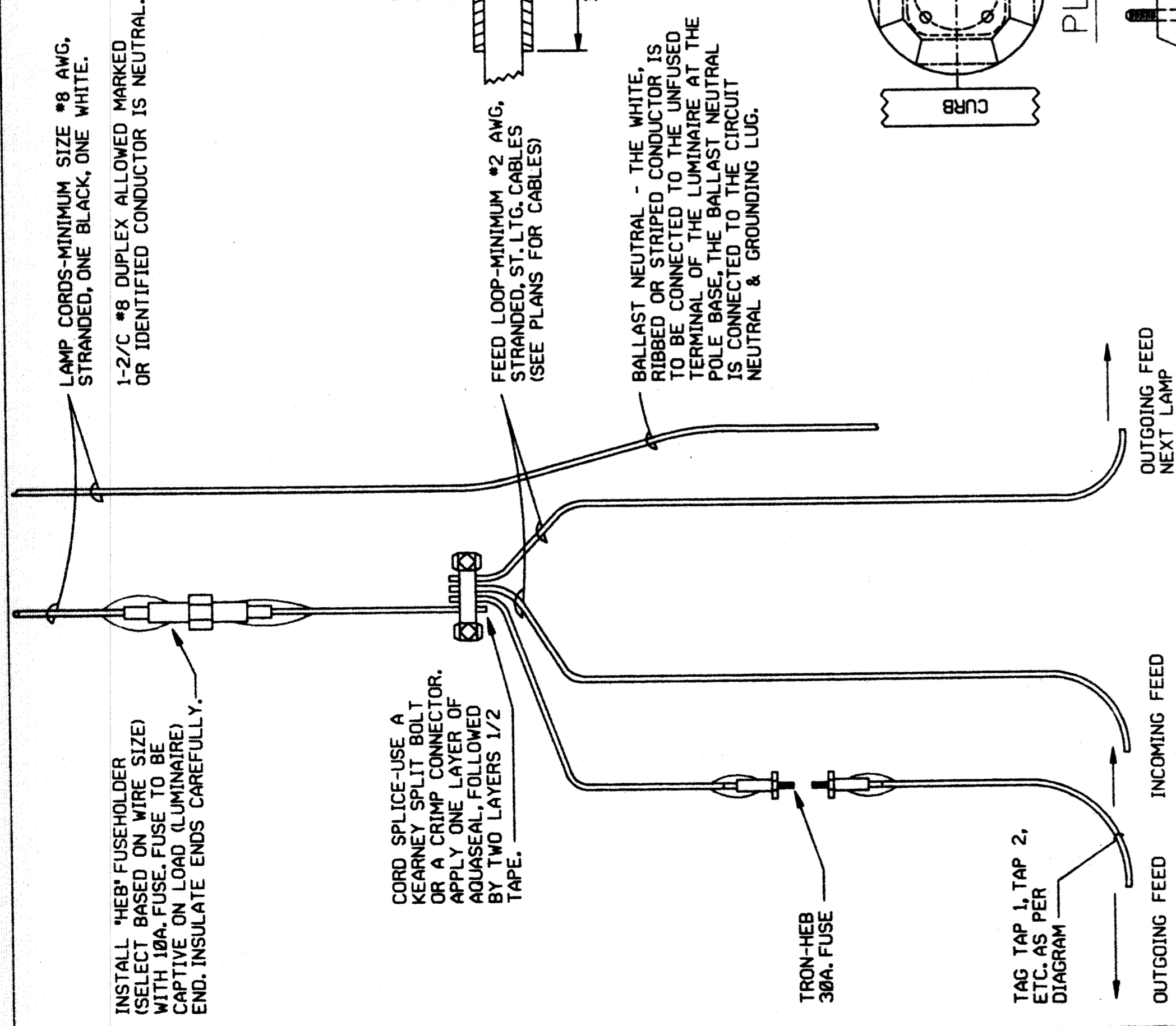

MULTIPLE STREET LIGHTING CONNECTION IN POLE BASE
N.T.S.

CLAMP SIZE TABLE

TYPE	POLE DIAMETER
A	3.6"-4.5"
B	6.1"-6.9"
C	7.5"-8.5"

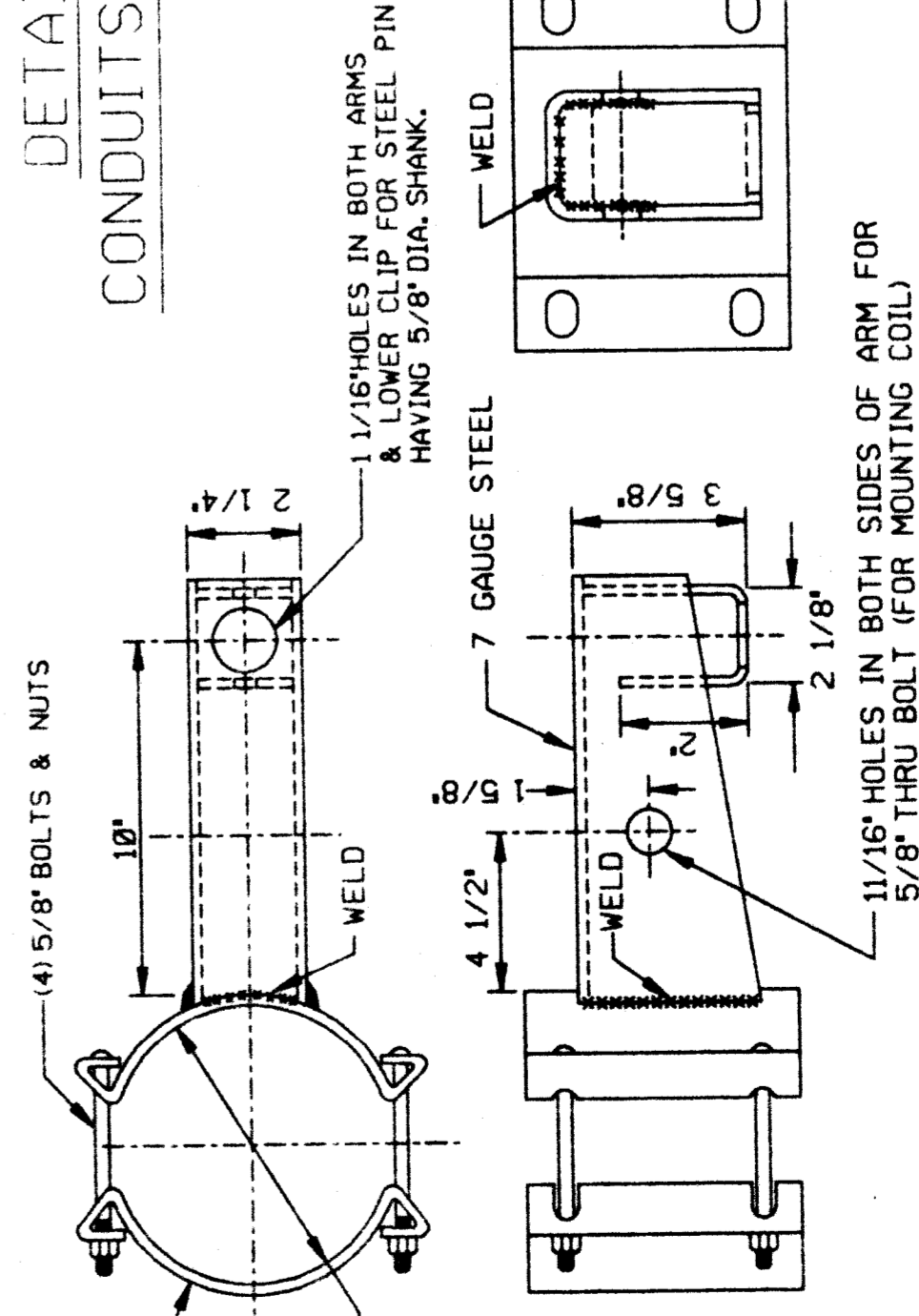

* FINISH SHALL BE HOT DIP GALVANIZED AFTER FABRICATION

CLAMP FEEDER ARM
N.T.S.

MULTIPLE STREET LIGHTING CABLE END
DETAIL OF SEALING OF CABLE END
N.T.S.

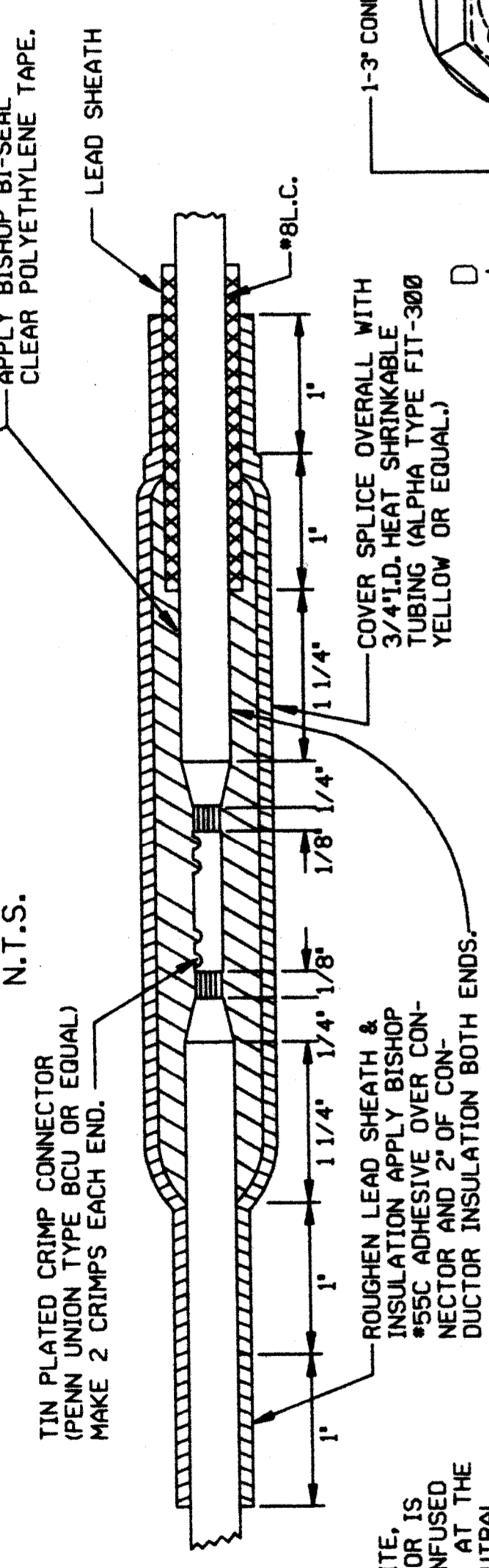

MULTIPLE STREET LIGHTING SPLICE DETAIL A
#8 L.C. TO #2 ST. LTG.
N.T.S.

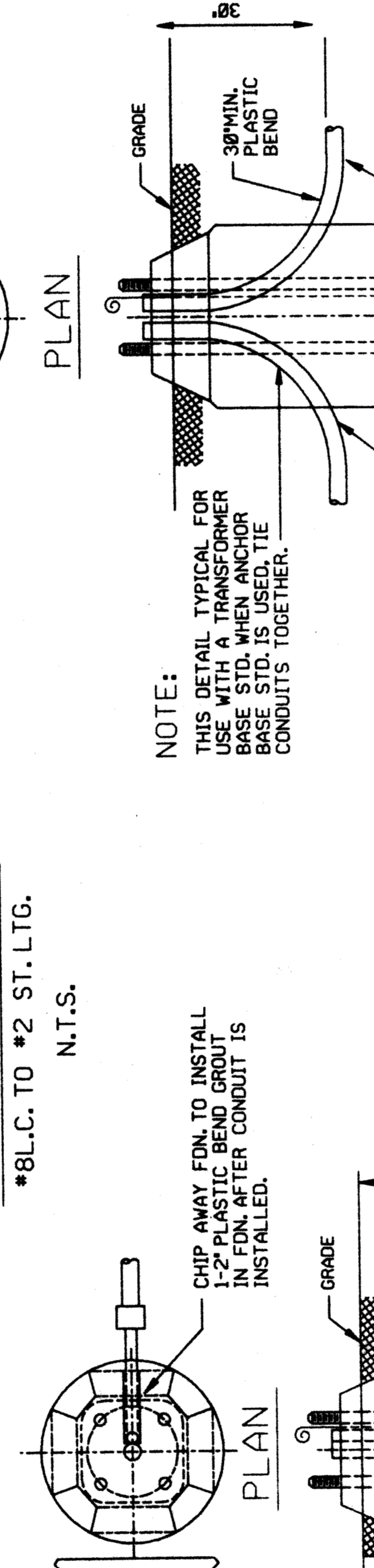

DETAIL OF INSTALLING CONDUITS IN & OUT OF NEW FDN.
N.T.S.

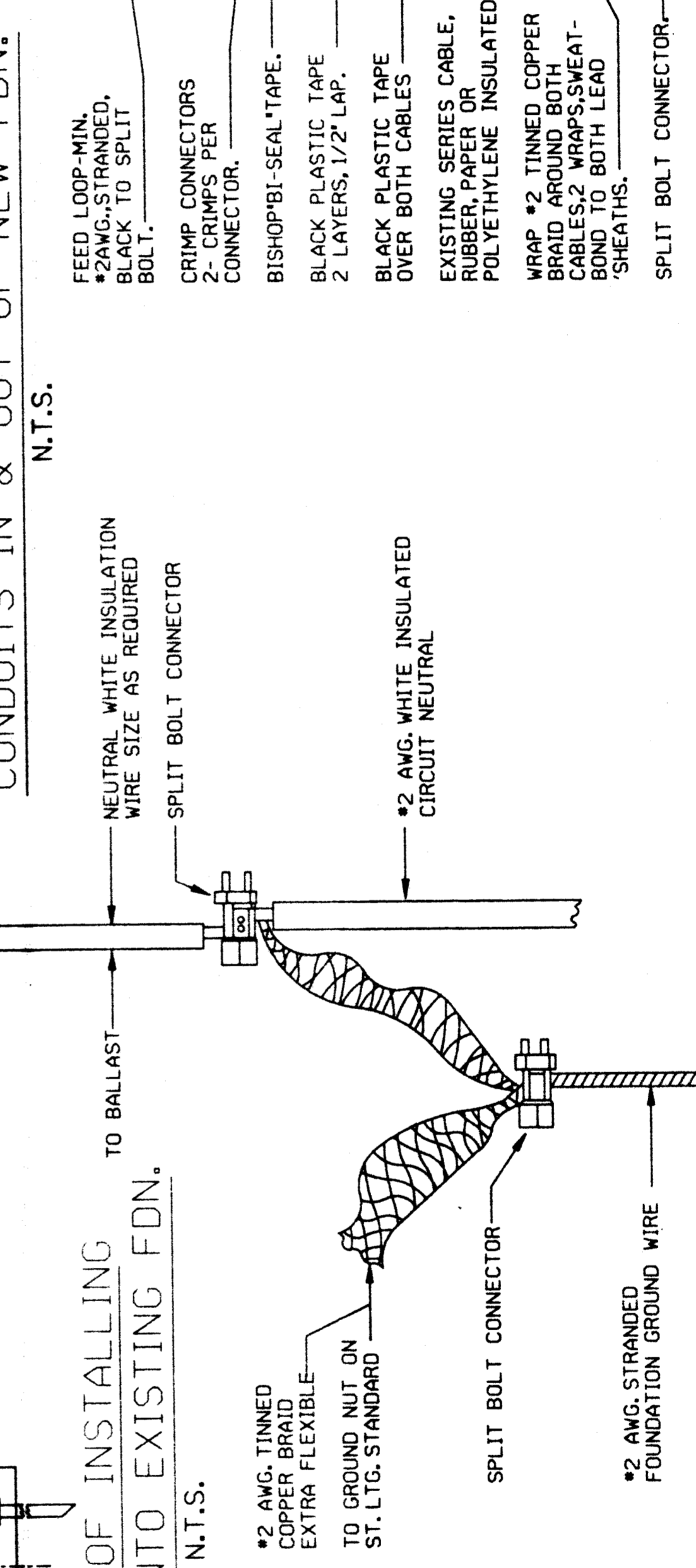

GROUND CONNECTION
N.T.S.

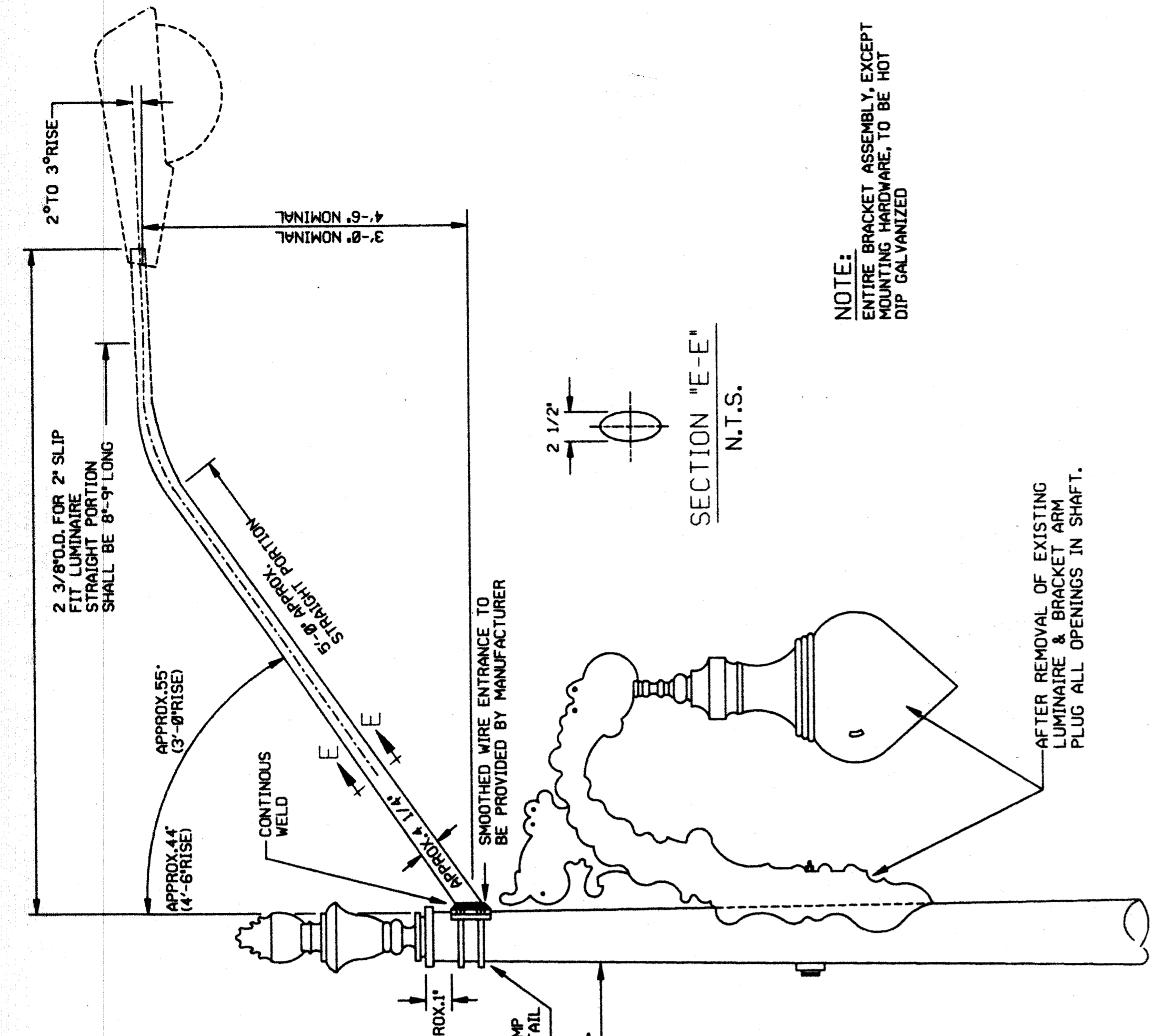
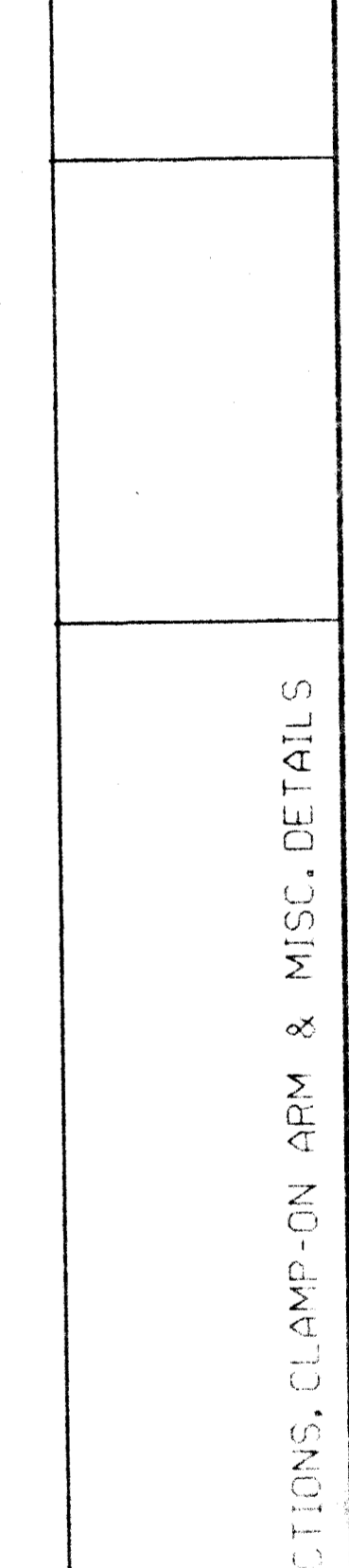

SECTION "E-E"
N.T.S.

CLAMP ON BRACKET ARM ELEVATION
N.T.S.

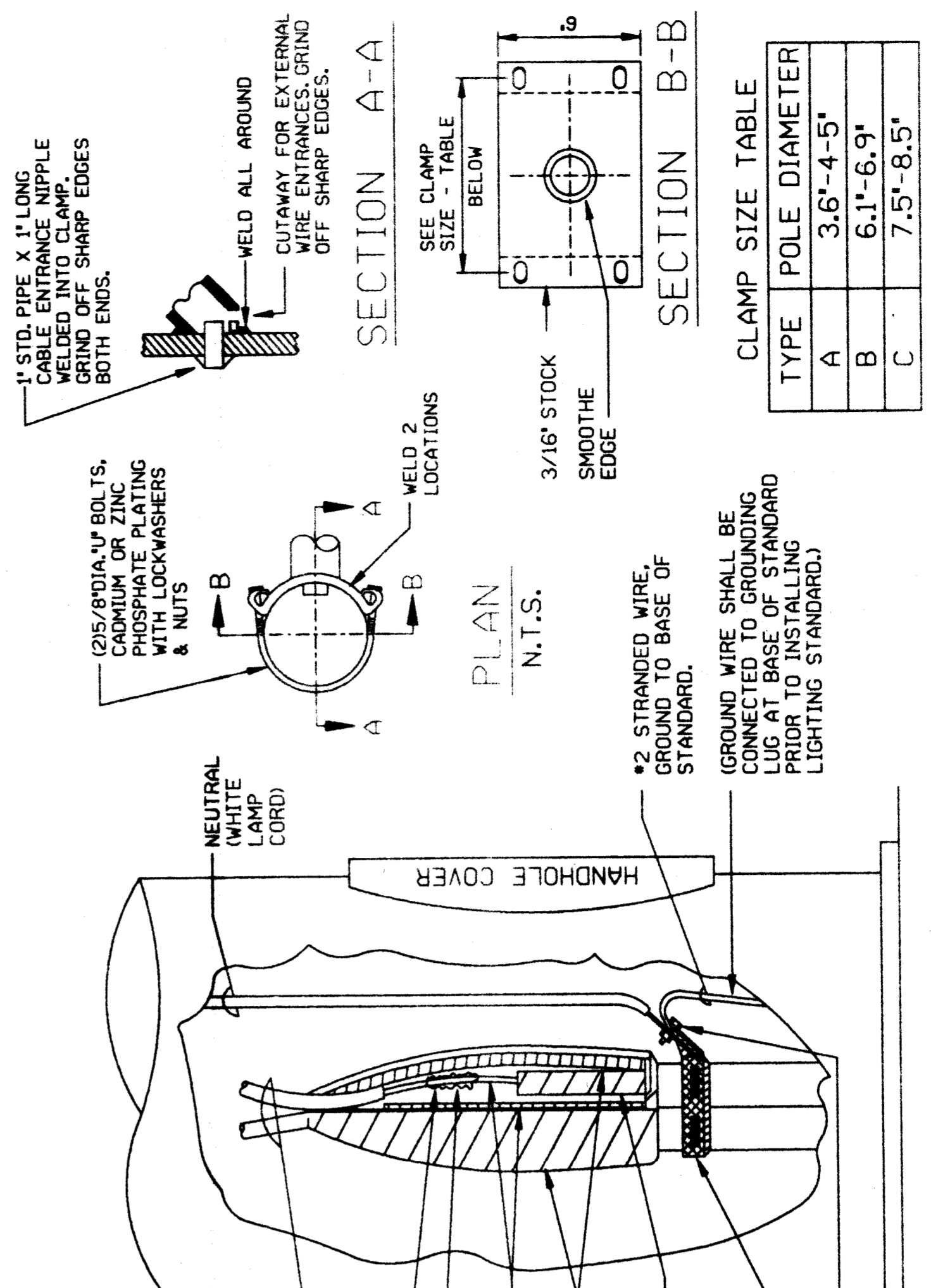

SERIES-TO-MULTIPLE LIGHTING CONVERSION POLE BASE CONNECTIONS
N.T.S.

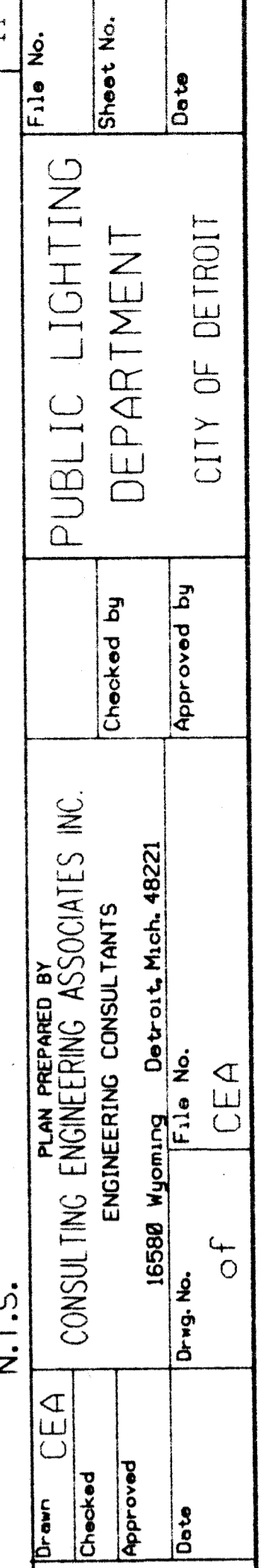

PLAN PREPARED BY
CEA
CONSULTING ENGINEERING ASSOCIATES INC.
ENGINEERING CONSULTANTS
16580 Wyoming Detroit, Mich. 48221
Drwg. No. of File No. Date

Checked by
CEA

Approved by
CEA

Checked by
CEA

Approved by
CEA

PIPE CLAMP DETAILS
N.T.S.

TYPE	POLE DIAMETER
A	3.6"-4.5"
B	6.1"-6.9"
C	7.5"-8.5"

File No. 114
Sheet No. 114
Date

Date	Description	Chkd. by

MULTI-ST. LTG. CABLE CONNECTIONS, CLAMP-ON ARM & MISC. DETAILS

PUBLIC LIGHTING DEPARTMENT
CITY OF DETROIT

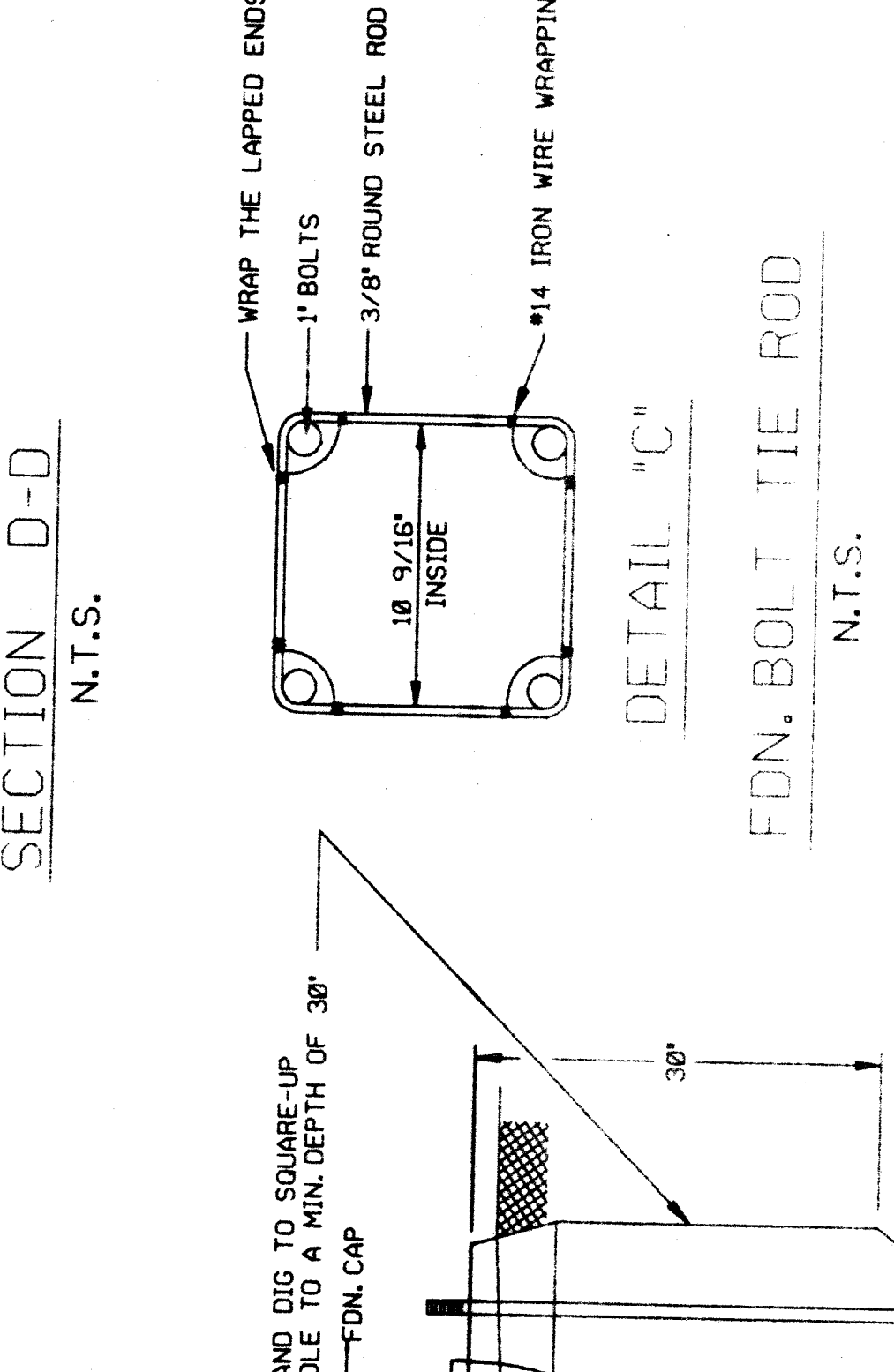
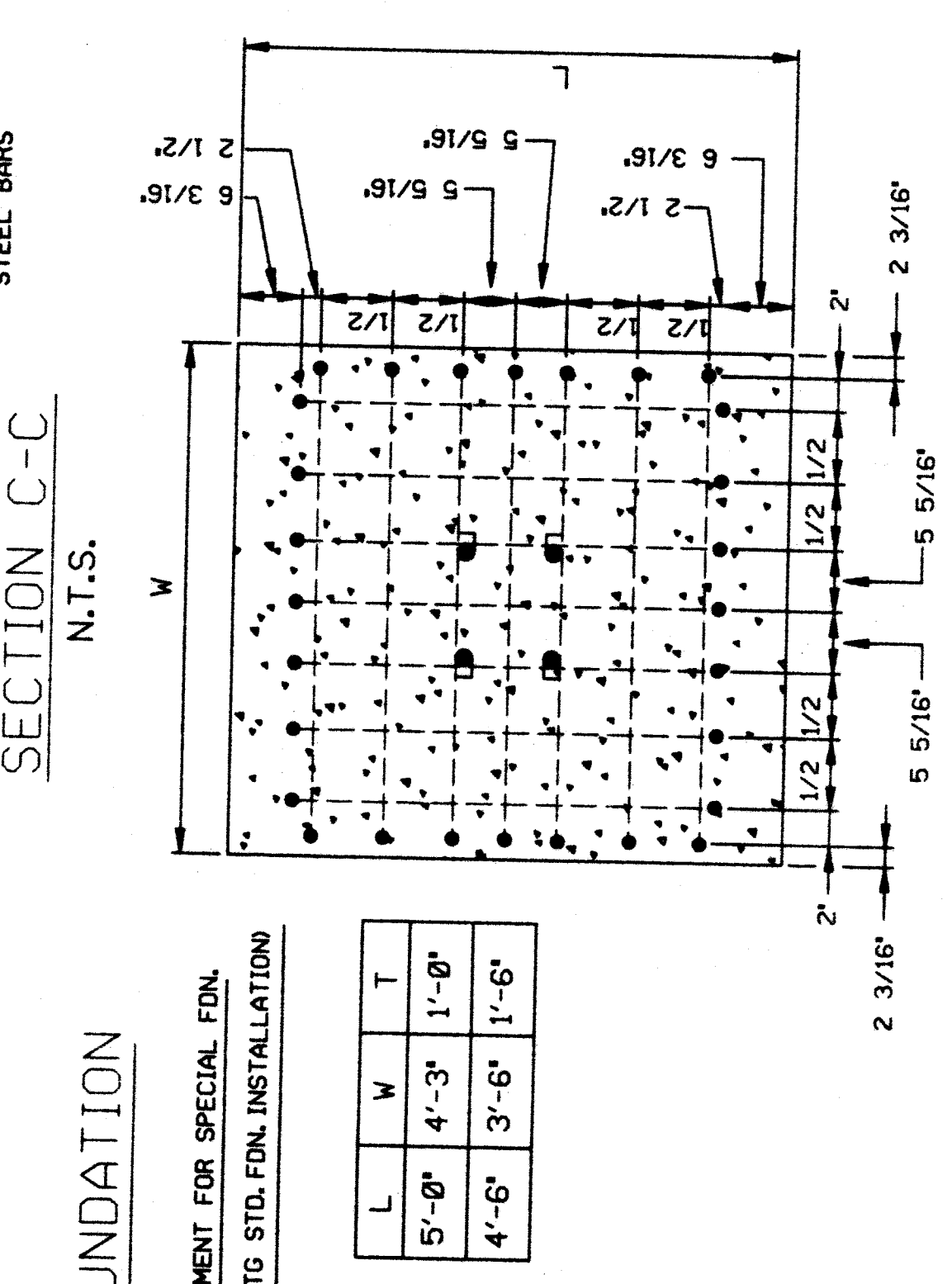
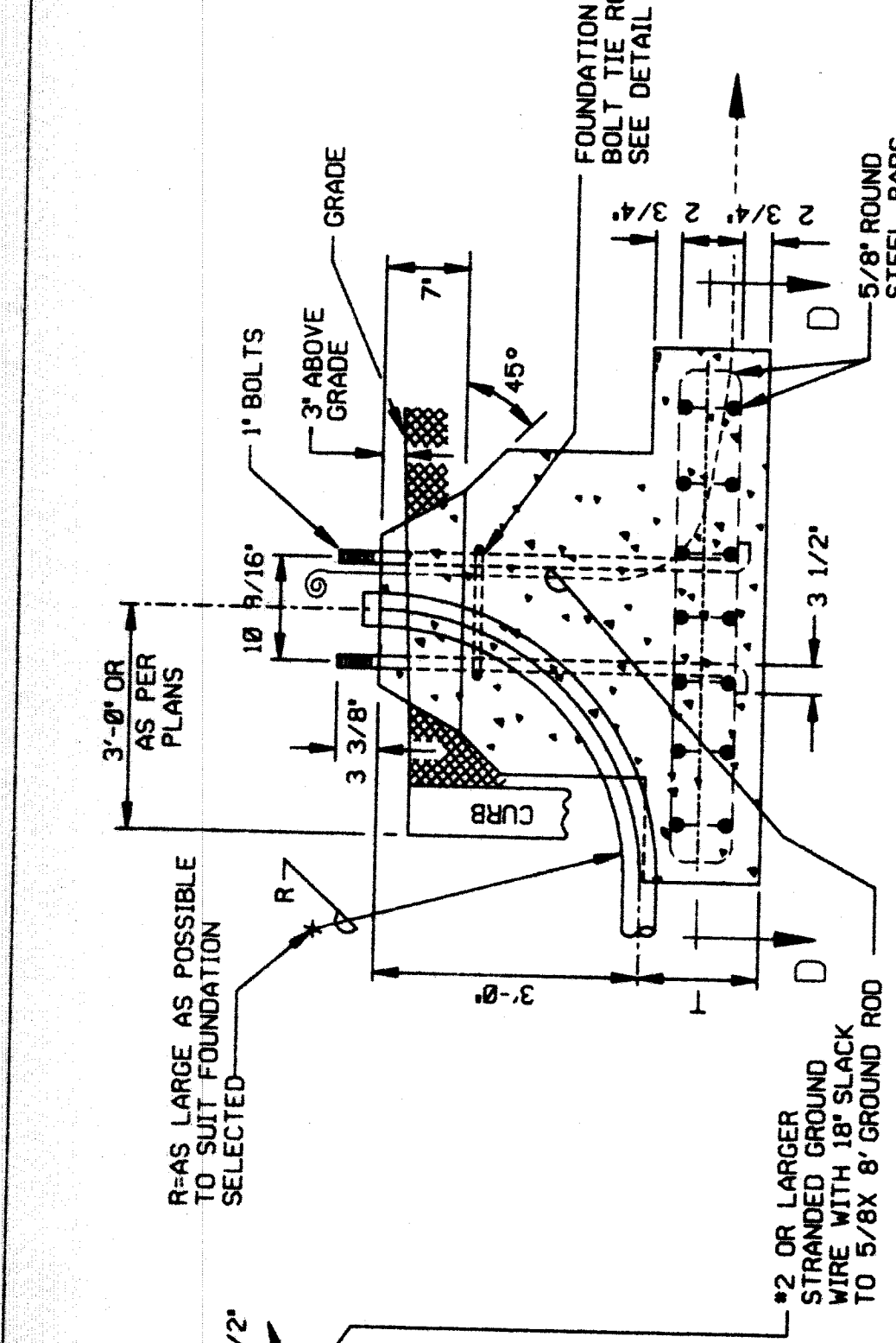

ALL FOUNDATION CAPS SHALL HAVE A SMOOTH FINISH WITH BEVELED EDGES & SHALL BE SHAPED TO ALLOW COMPLETE DRAINAGE OF WATER. ANCHOR BOLT PROJECTIONS ABOVE CAP SHALL BE CLEANED OF ALL CONCRETE & FULLY USABLE THEIR FULL LENGTH.

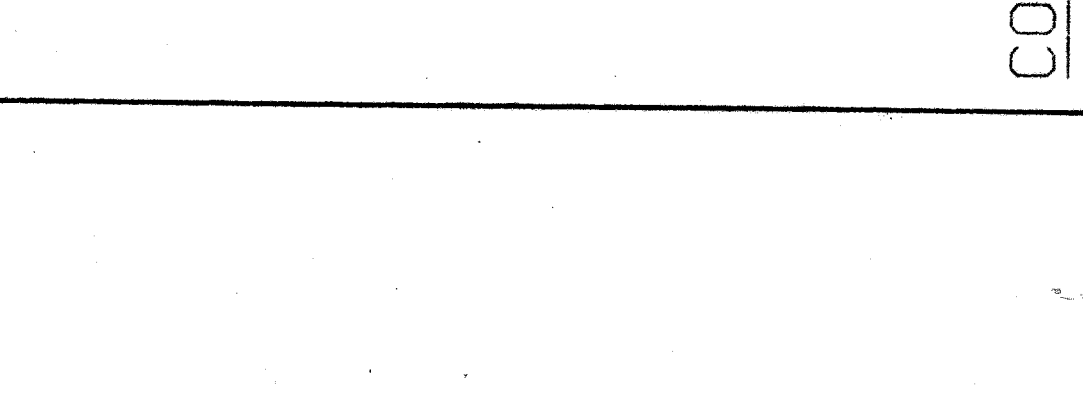
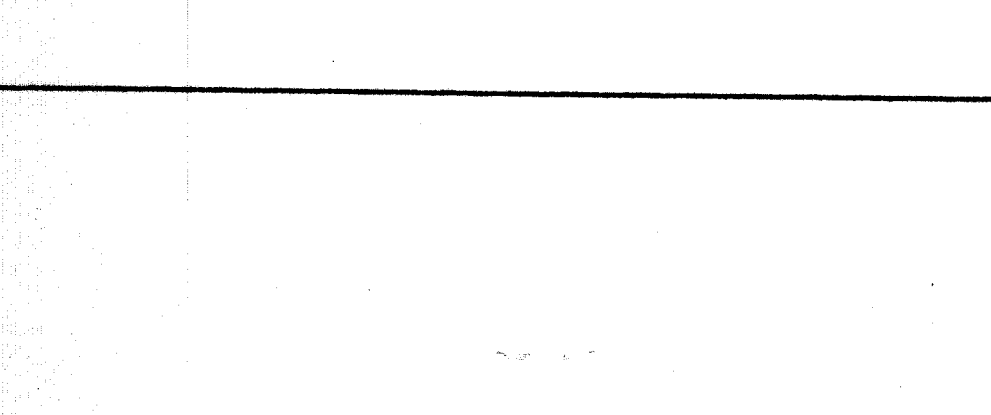
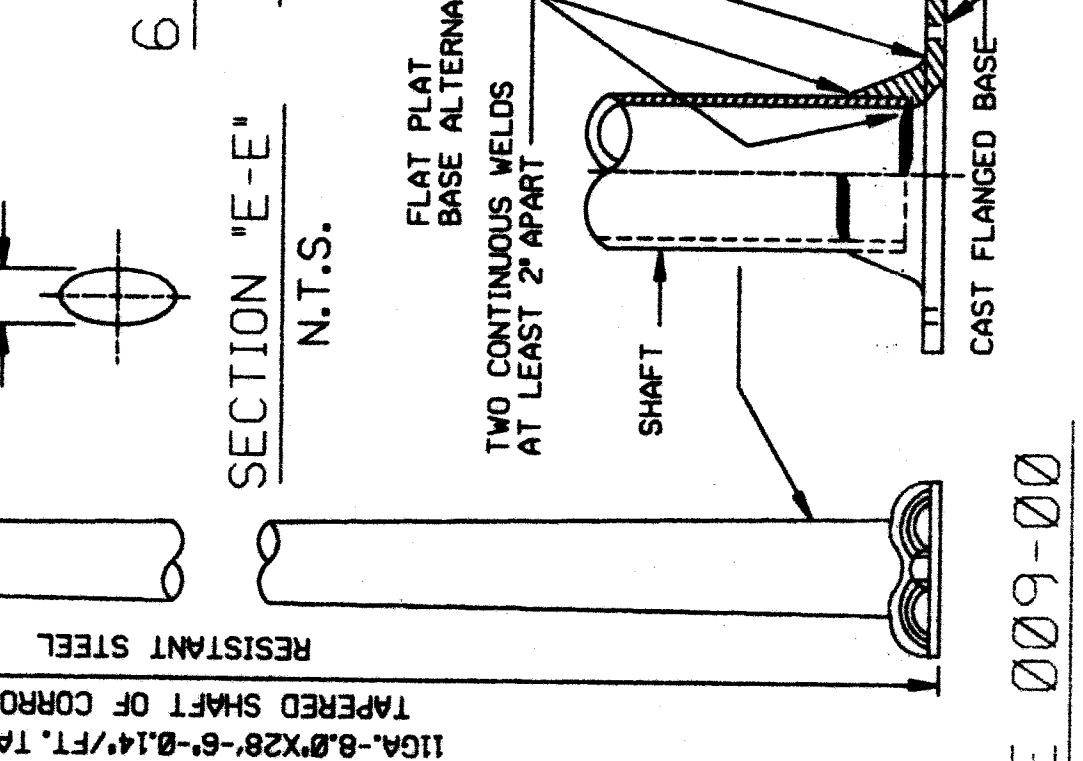
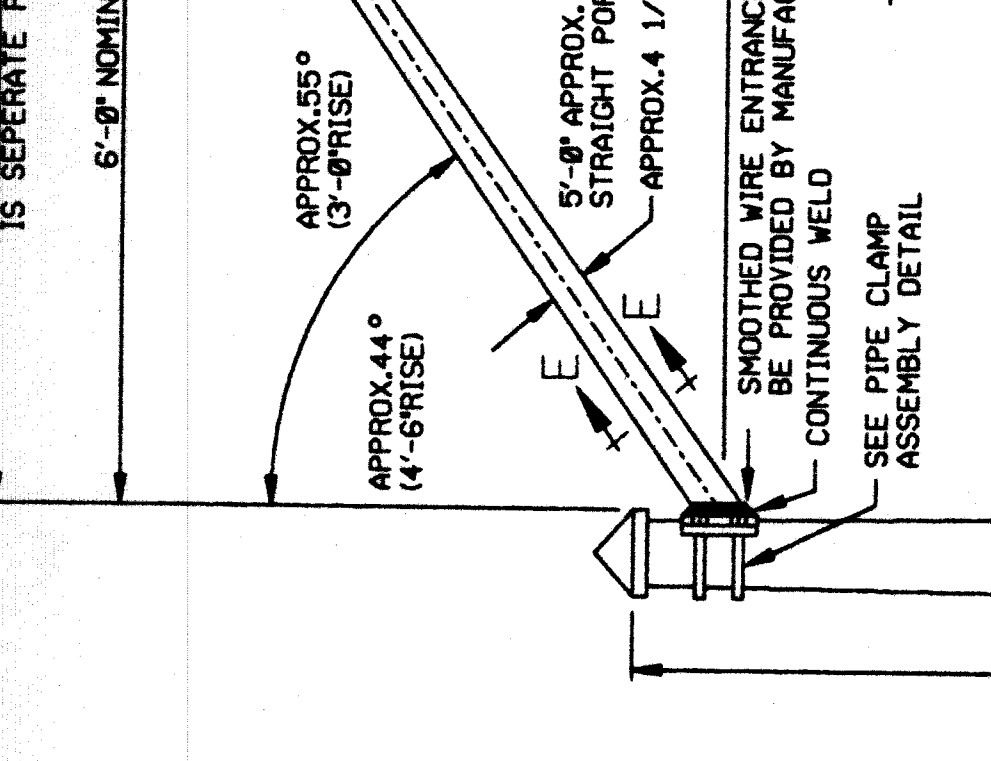
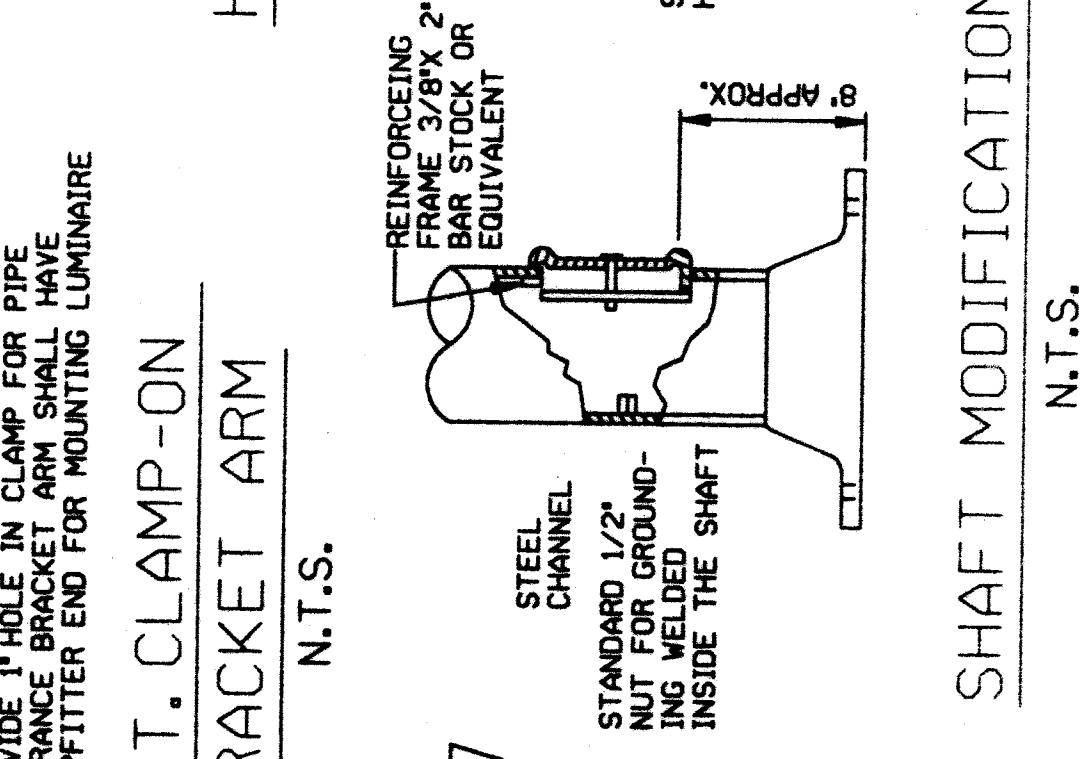
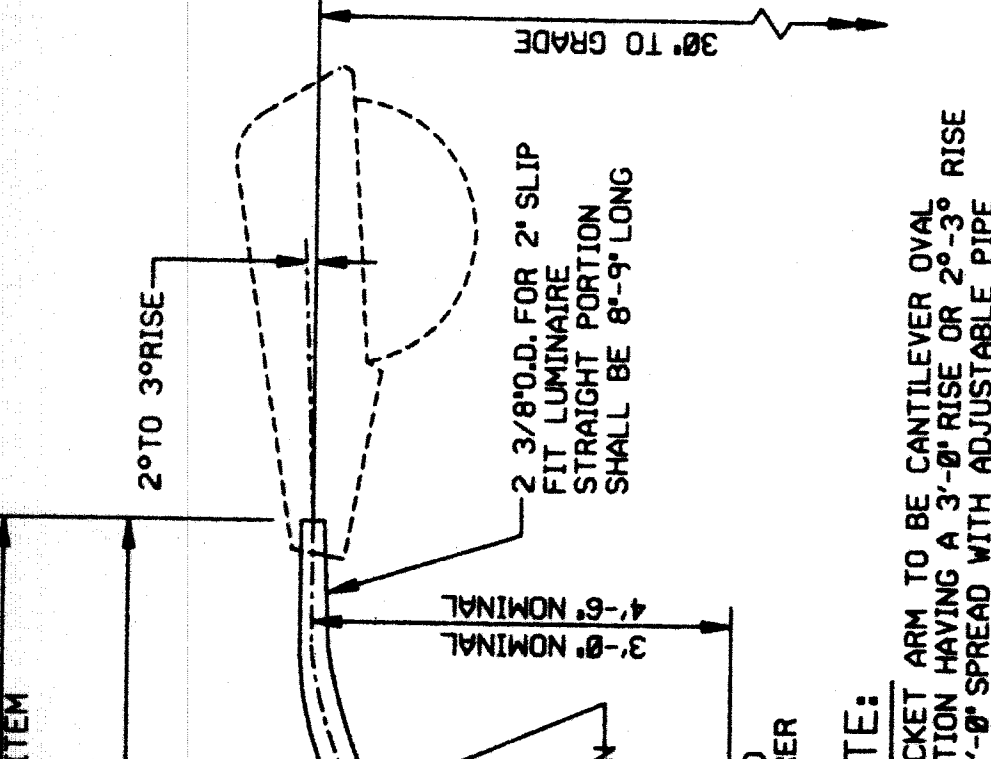
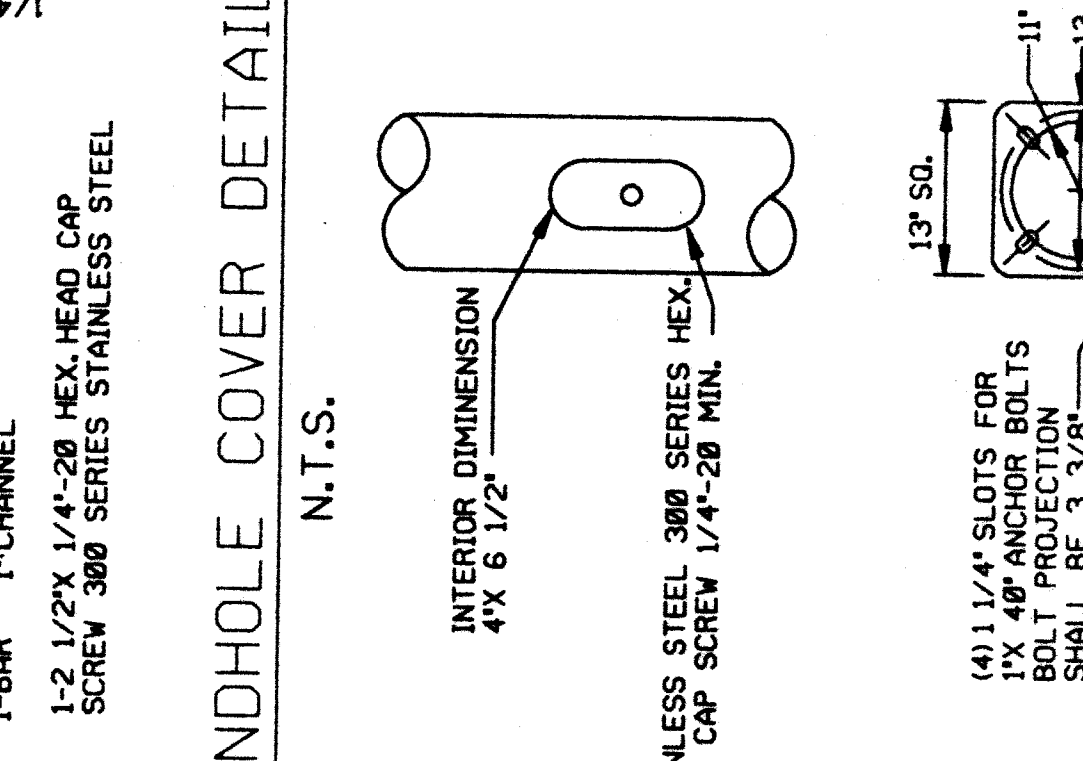
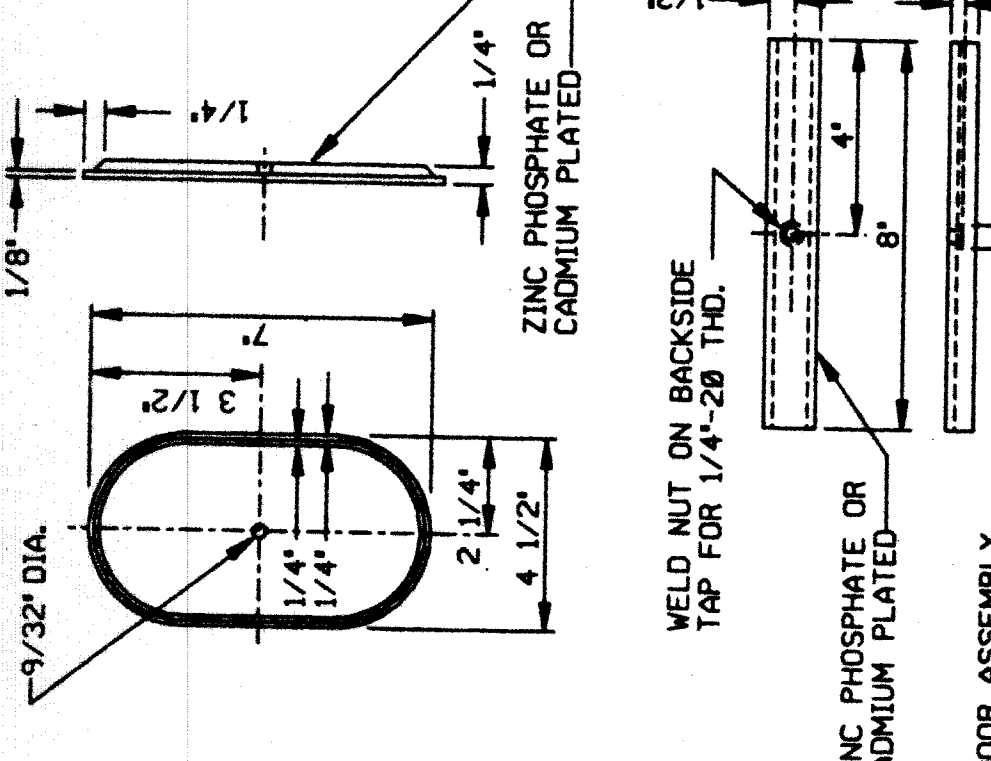
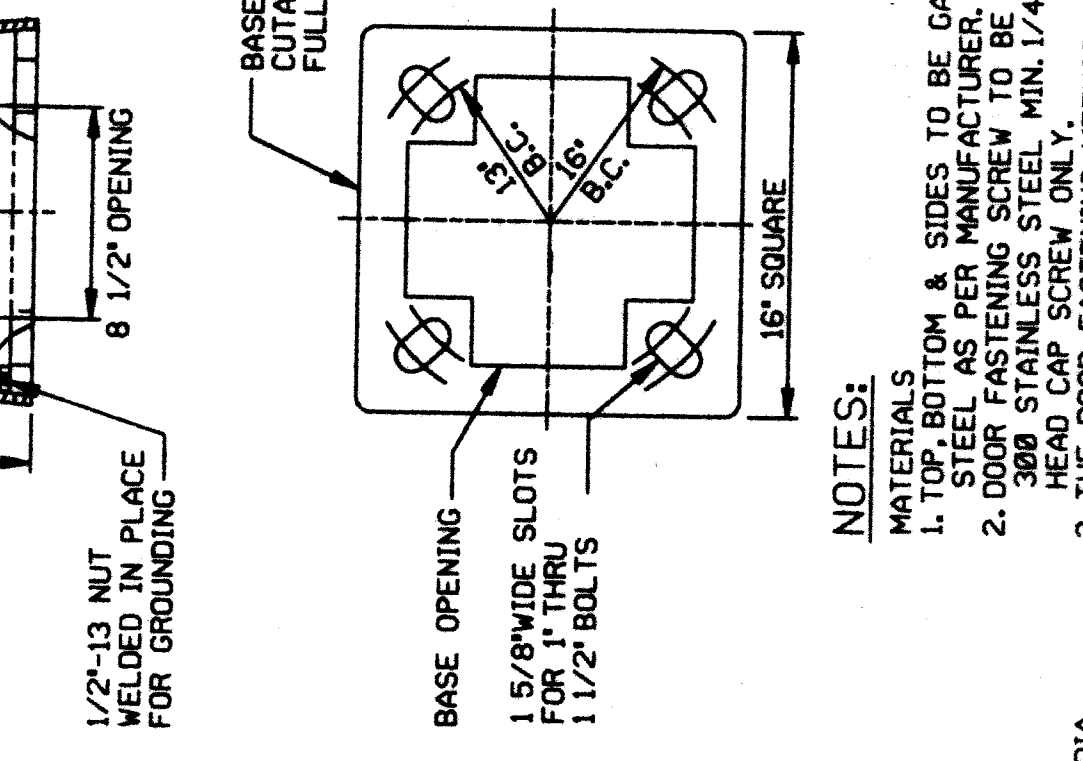
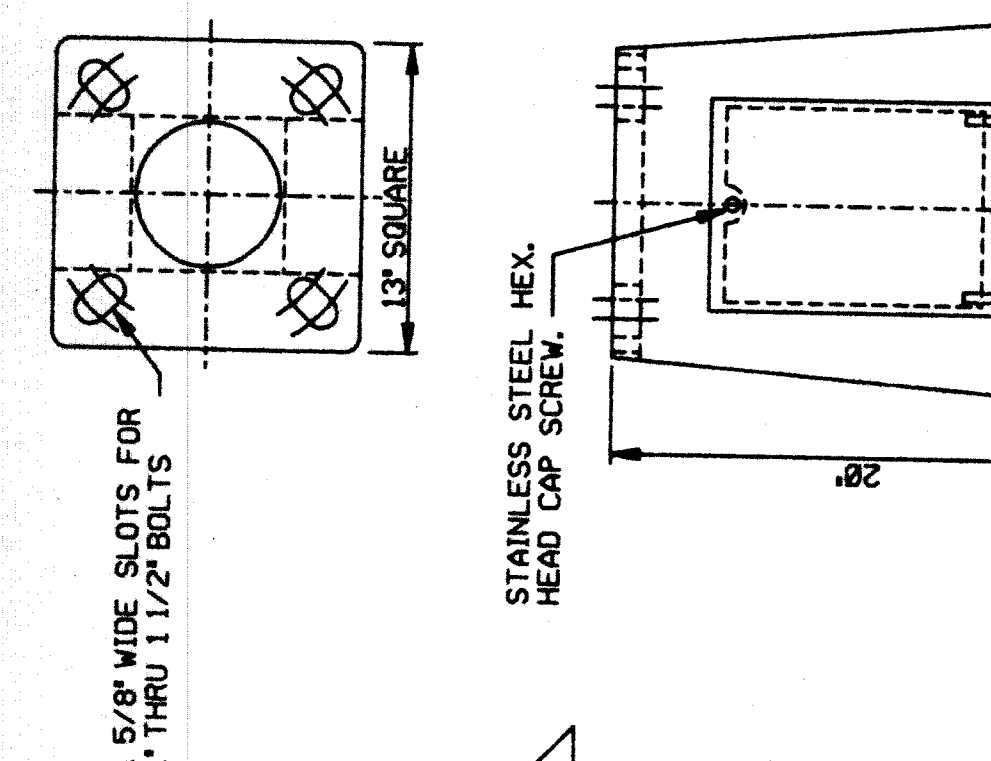
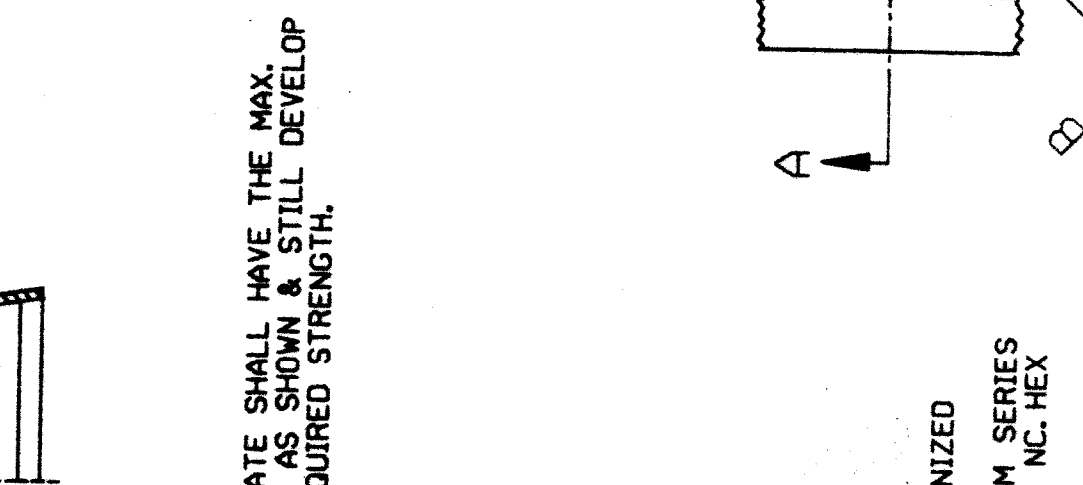
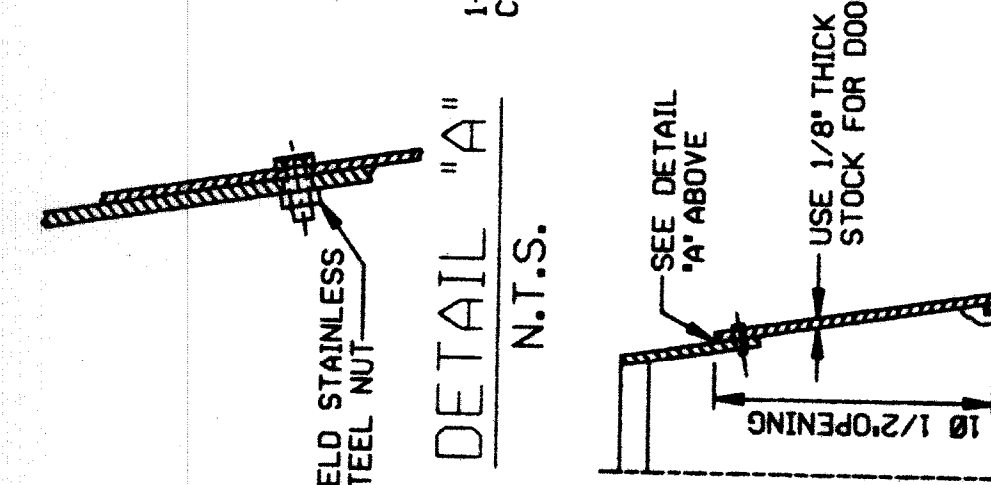
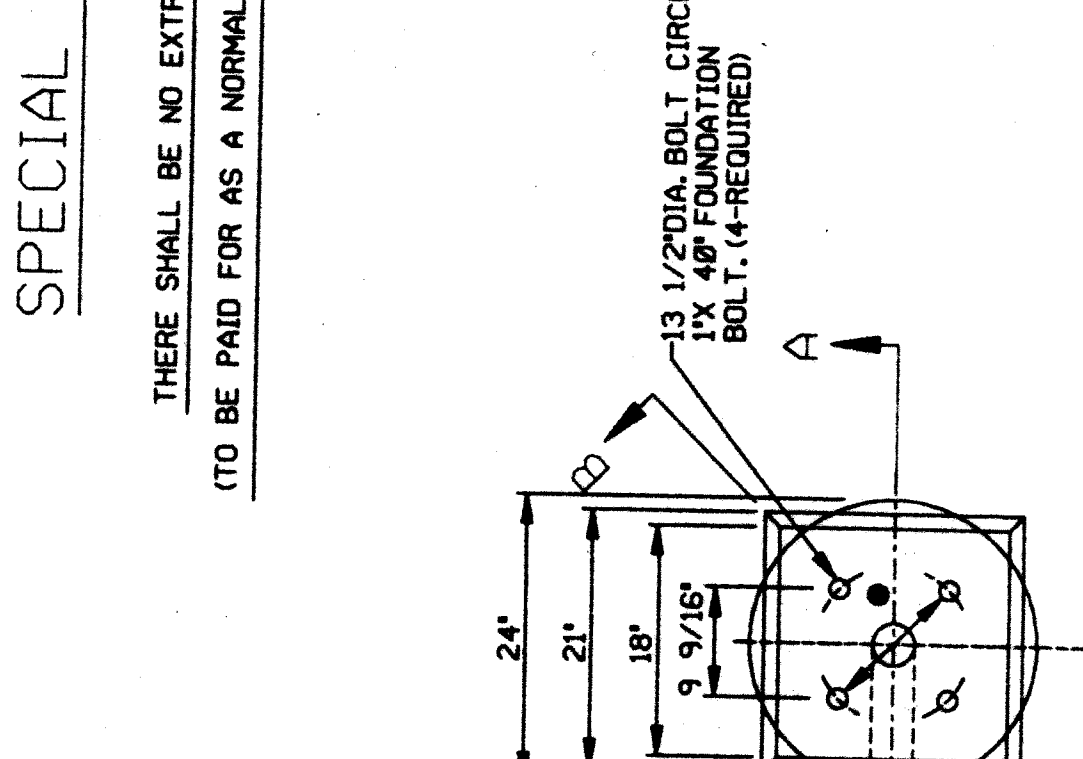
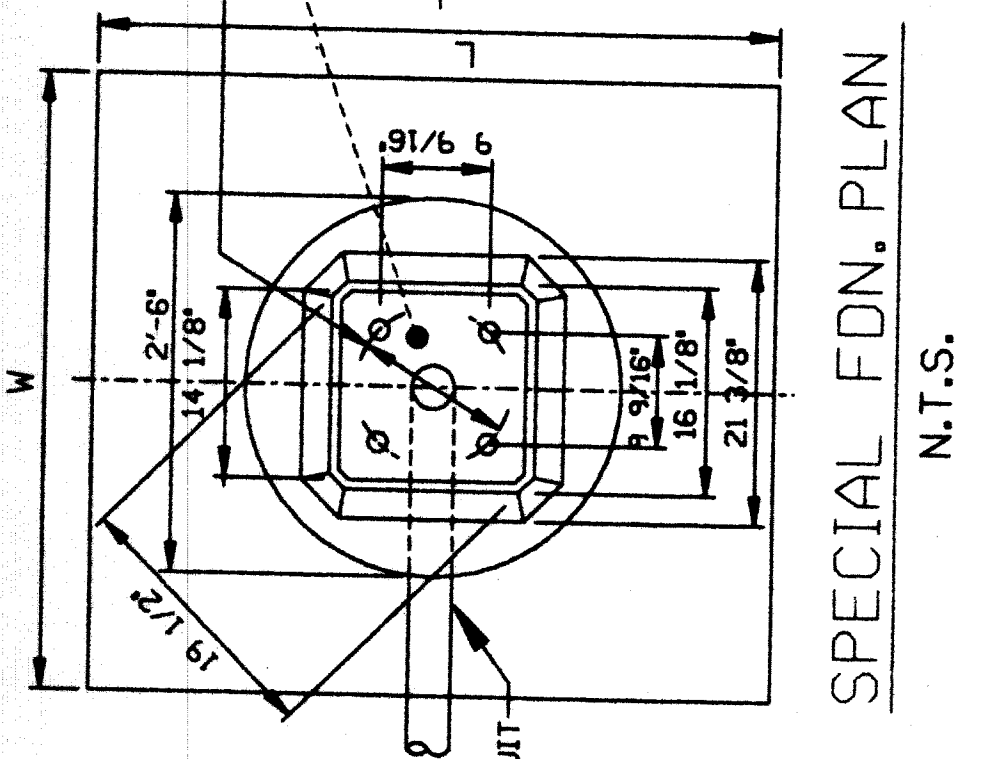

THERE SHALL BE NO EXTRA PAYMENT FOR SPECIAL FDN. (TO BE PAID FOR AS A NORMAL ST. LITG. STD. FDN. INSTALLATION)

NOTES:
MATERIALS:
1. TOP, BOTTOM & SIDES TO BE GALVANIZED STEEL AS PER MANUFACTURER.
2. DOOR FASTENING SCREW TO BE ASTM SERIES 308 STAINLESS STEEL MIN. 1/4\"-28 NC. HEX HEAD SCREWS.
3. THE DOOR FASTENING METHOD SHALL USE ONLY ONE HEX. HEAD CAP SCREW SERIES 308 STAINLESS STEEL. MULTIPLE SCREWS WILL NO LONGER BE ALLOWED TO INSURE PROPER FIELD INSTALLATION AND OPERATION.

P.L.D. UNIVERSAL STEEL TRANSFORMER BASE N.T.S.

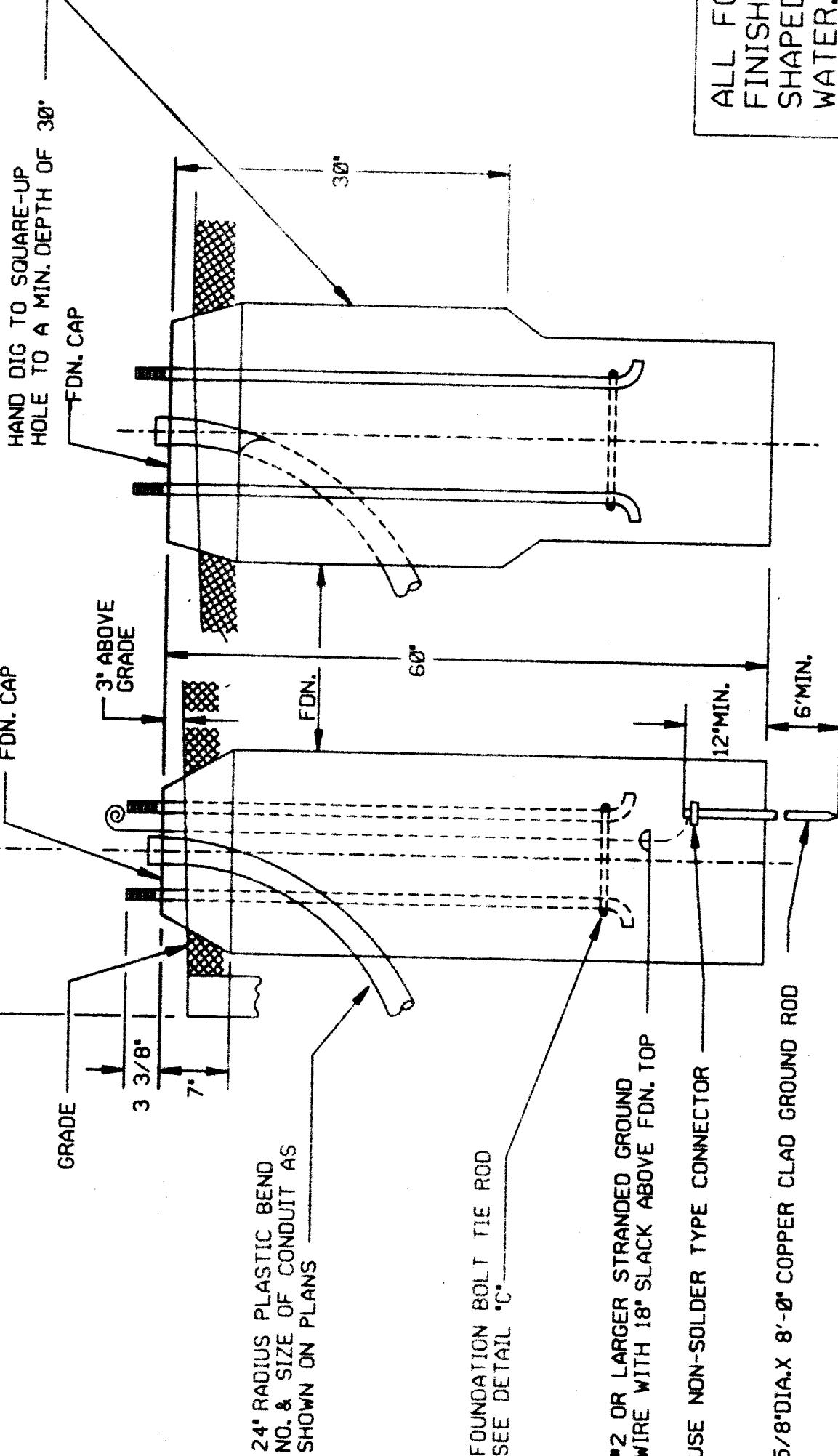

SECTION A-A N.T.S.

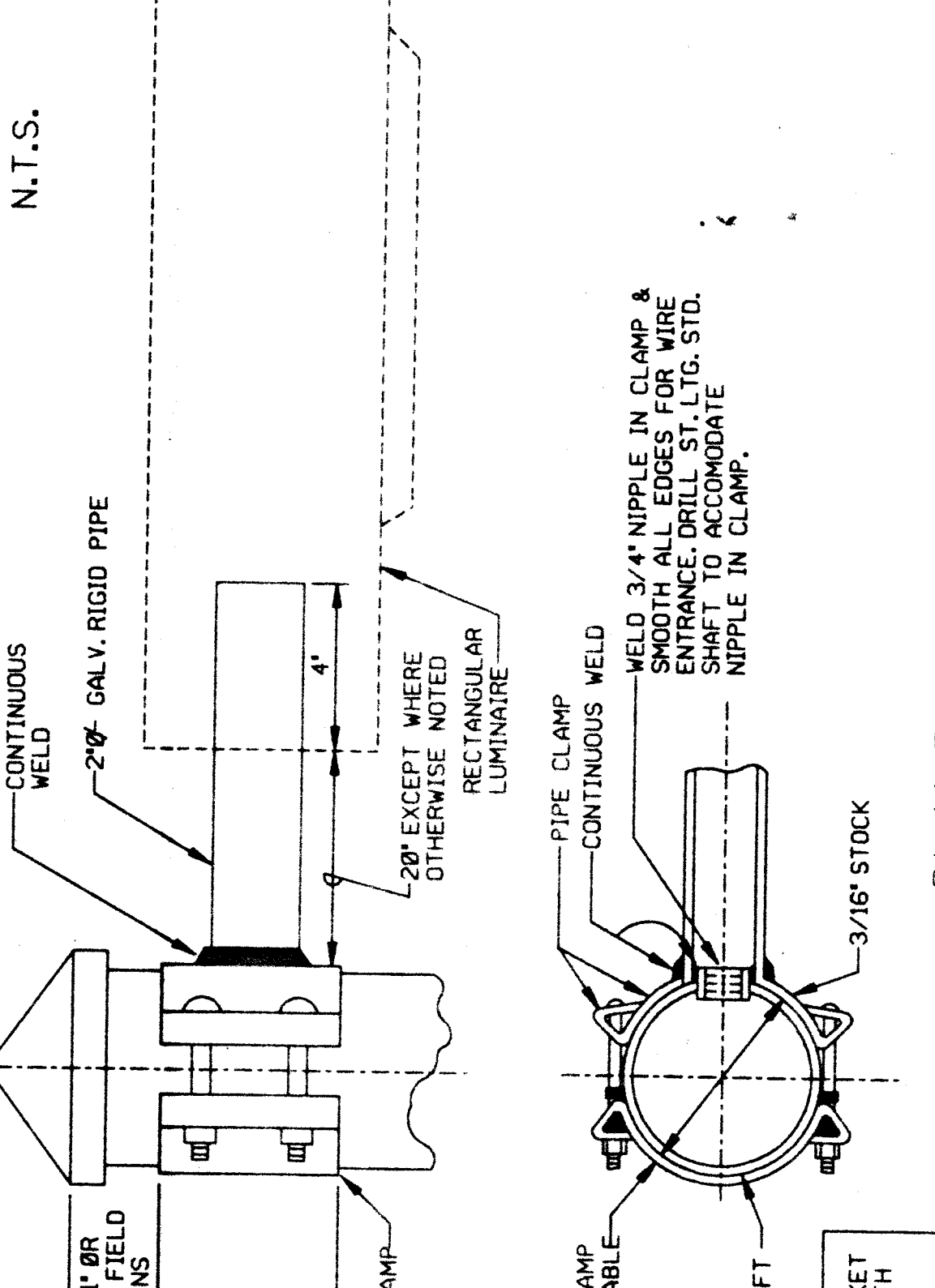

SECTION B-B N.T.S.

ANCHOR BASE STD. FOUNDATION

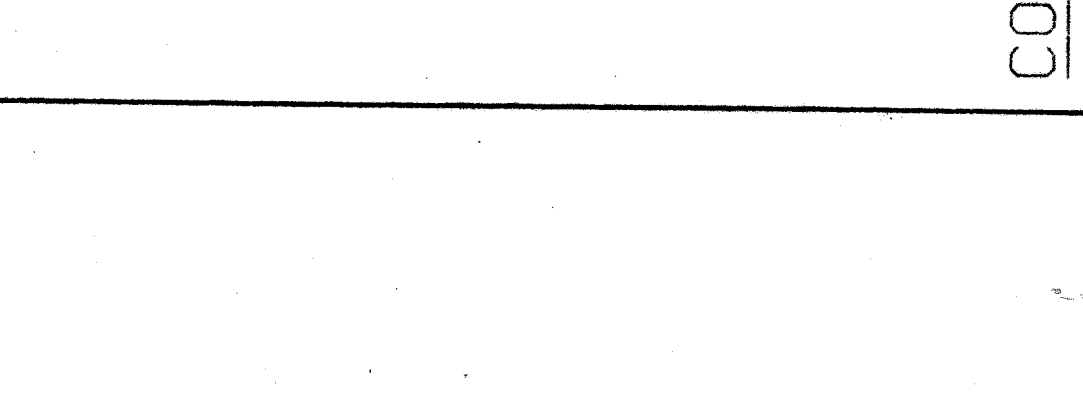
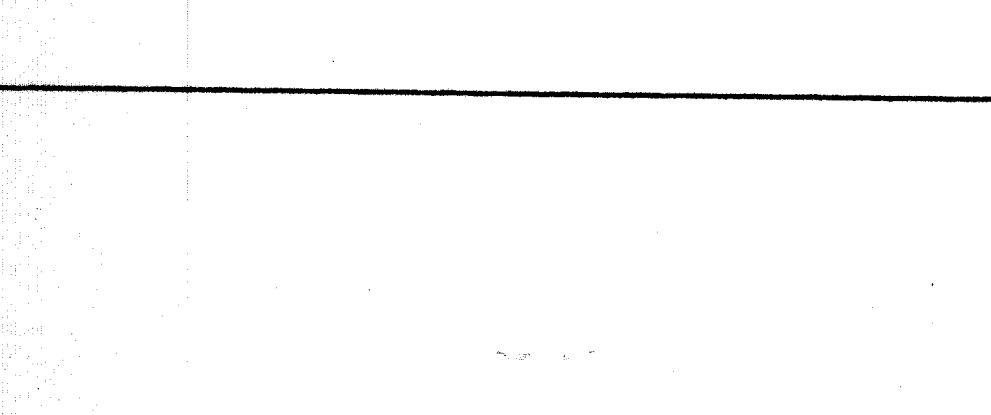
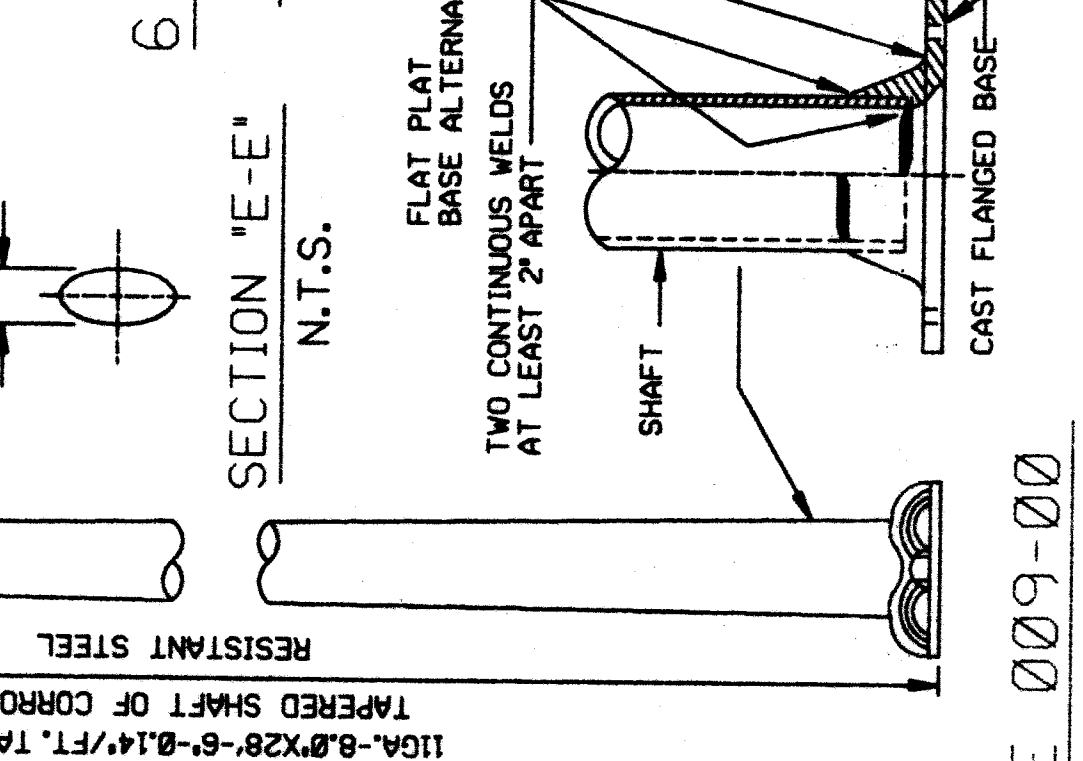
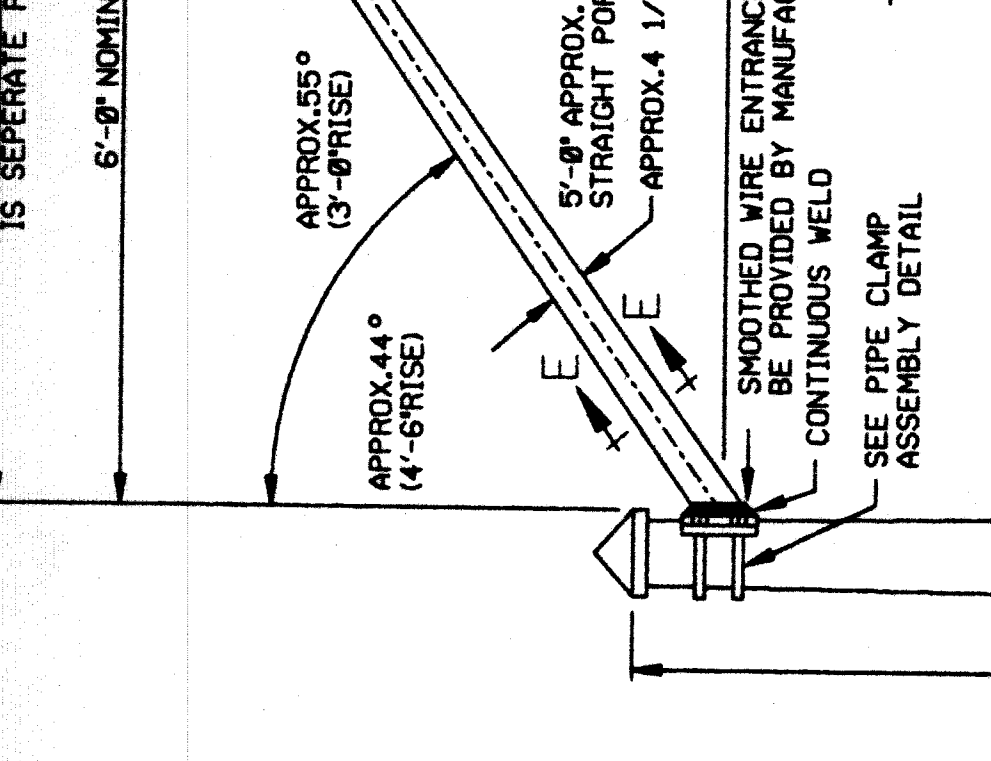
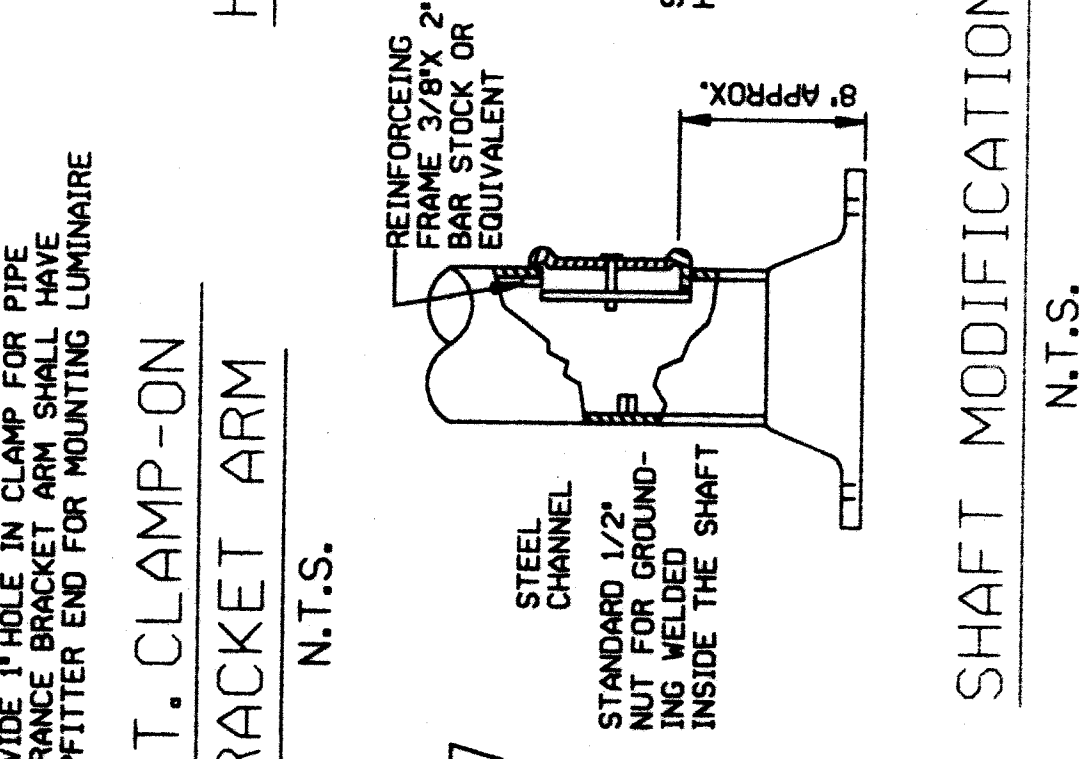
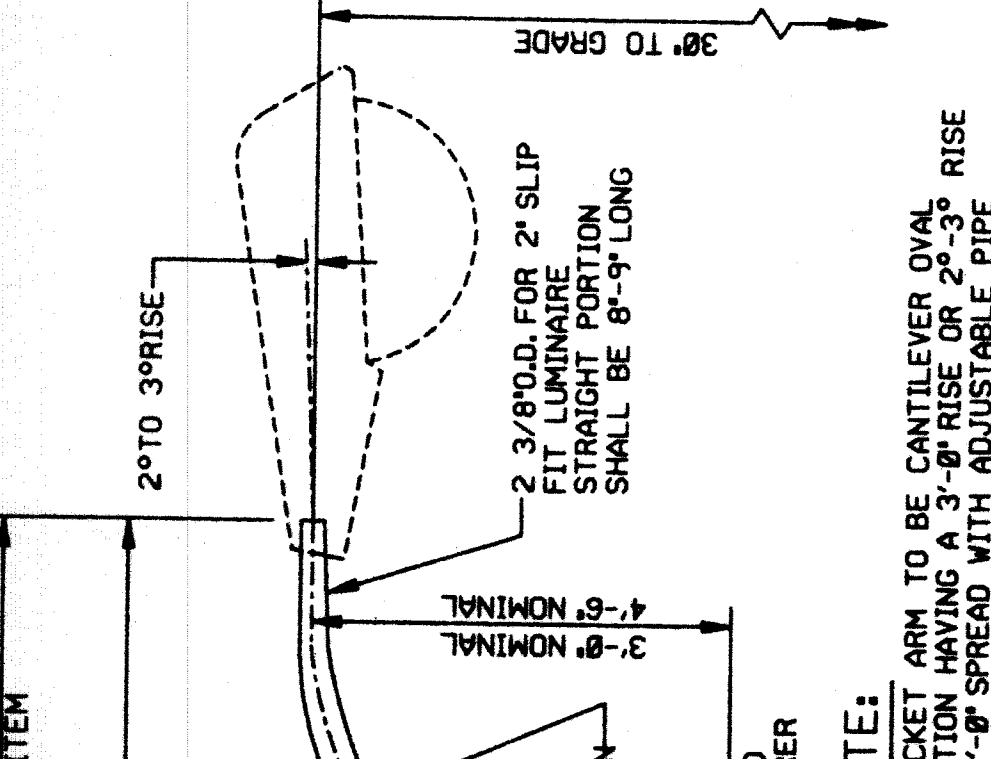
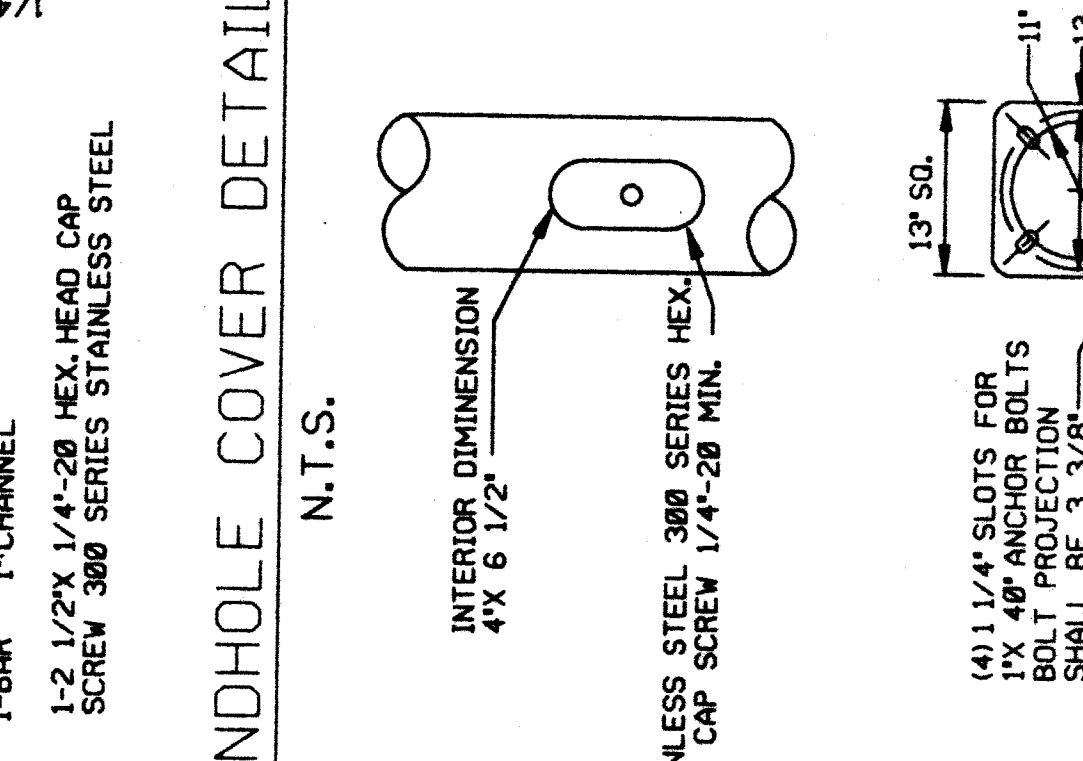
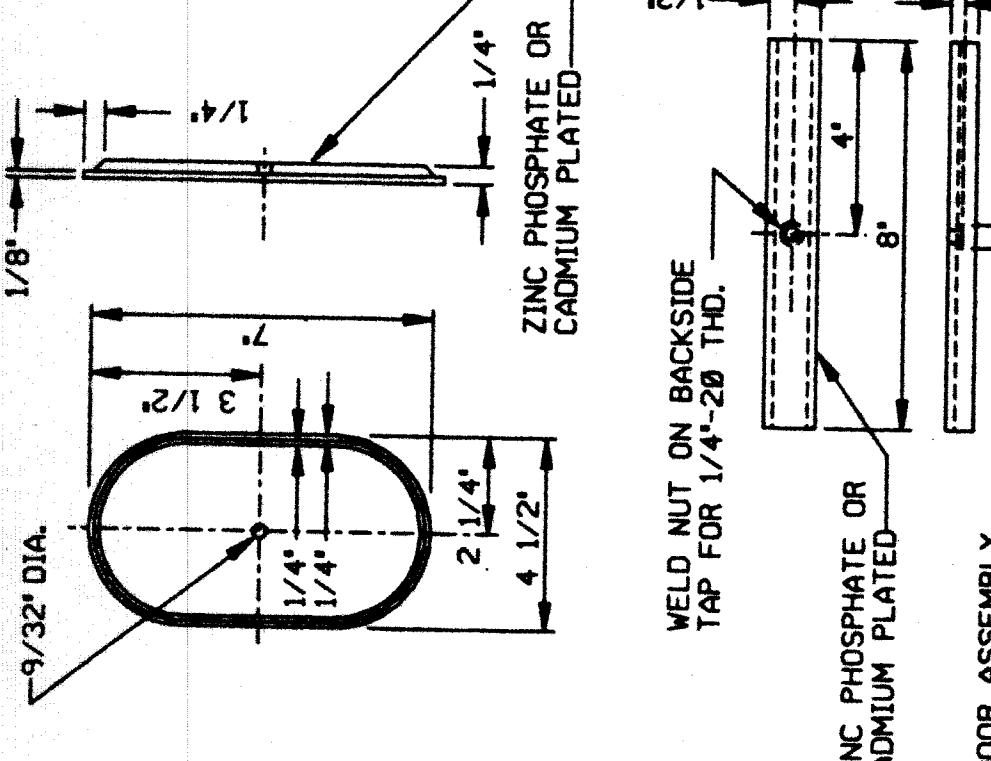

CODE 009-00 STREET LIGHTING STANDARD N.T.S.

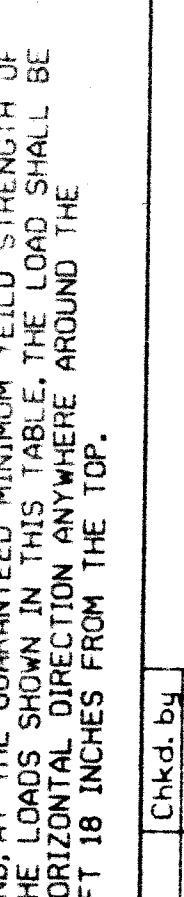
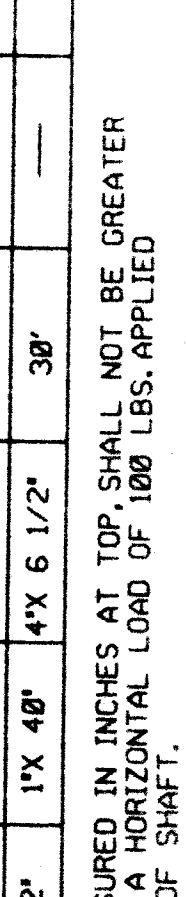
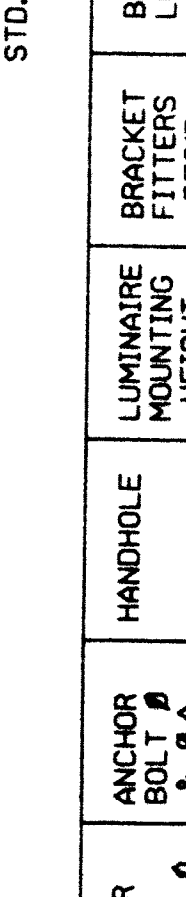
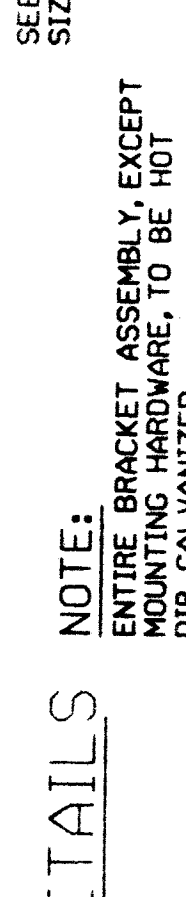
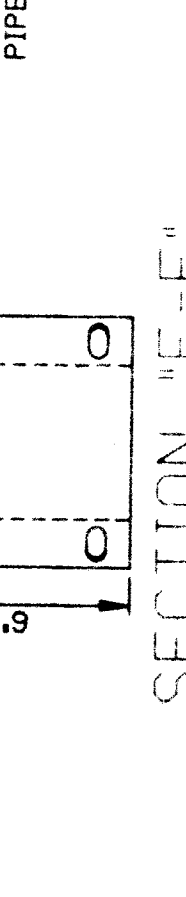
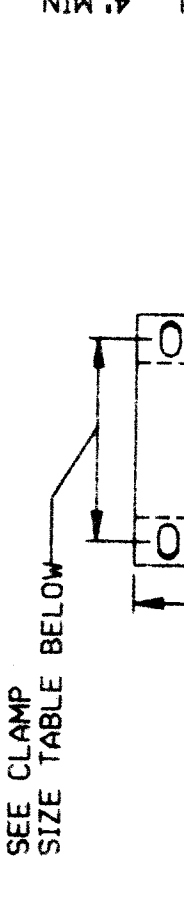
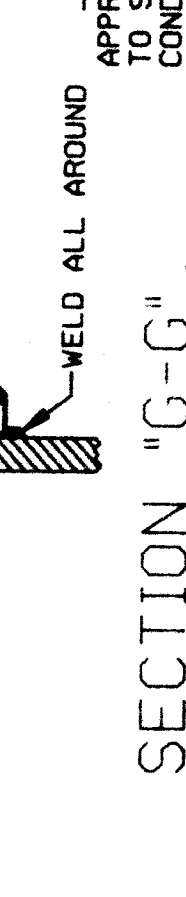
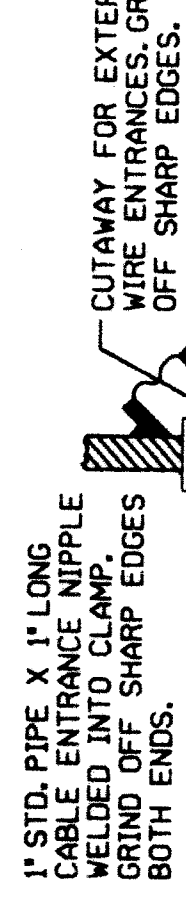

TYPE	POLE DIAMETER
A	3.6\"-4.5\"
B	6.1\"-6.9\"
C	7.5\"-8.5\"

PIPE CLAMP DETAILS N.T.S.

STD. CODE NO.	SHAFT LENGTH	SHAFT DEFLECTION	MINIMUM LOAD	ANCHOR BOLT # & DIA.	ANCHOR BOLT CIRCLE D	HANDHOLE	LUMINAIRE MOUNTING HEIGHT	BRACKET FITTERS REQ'D	BRACKET LENGTH
009-00	28'-6"	2.9"	880#	1\" x 48"	4\" x 6 1/2"	38"	—	—	6'

SHAFT DEFLECTION: SHAFT DEFLECTION MEASURED IN INCHES AT TOP SHALL NOT BE GREATER THAN THAT SHOWN FROM A HORIZONTAL LOAD OF 100 LBS. APPLIED 18 INCHES BELOW TOP OF SHAFT.

SHAFTS SHALL WITHSTAND AT THE GUARANTEED MINIMUM YIELD STRENGTH OF THE SHAFT MATERIAL, THE LOADS SHOWN IN THIS TABLE. THE LOAD SHALL BE APPLIED IN A SINGLE HORIZONTAL DIRECTION ANYWHERE AROUND THE CIRCUMFERENCE OF SHAFT 18 INCHES FROM THE TOP.

SHAFT LOADING

SHAFT DEFLECTION

MINIMUM LOAD

ANCHOR BOLT # & DIA.

ANCHOR BOLT CIRCLE D

HANDHOLE

LUMINAIRE MOUNTING HEIGHT

BRACKET FITTERS REQ'D

BRACKET LENGTH

CLAMP SIZE TABLE

USE	VOLT	ITEM	RATING	NO.	CONDUCTOR	SYNTHETIC RUBBER	IMPRG- YLENE	POLYETH- CHLORINYL-	SHIELD OVER INSULATED CONDUCTORS	TAPE OVER INSULATED CONDUCTORS	IMPRG- NATED PAPER BELT	JACKET	LEAD SHEATH	COVERING OVER LEAD	STEEL ARMOR	COVERING OVER STEEL TAP	COVERING OVER POLYETHYLENE
				1	2-6 AWG. H.D. UNCOATED SOLID COPPER	A.S.T.M. B1											
				2	4/0-2/0 AWG. H.D. UNCOATED SOLID COPPER	A.S.T.M. B1											
				3	2- AWG. H.D. UNCOATED SOLID COPPER	A.S.T.M. B1											
				4	2- AWG. H.D. UNCOATED SOLID COPPER	A.S.T.M. B1											
				5	4/0-2/0 AWG. H.D. UNCOATED SOLID COPPER	A.S.T.M. B1											
				6	SPECIAL EVENT FEEDER	2000V.											
				7	MULTI-ST. L.T.O.	2000V.											
				8	TRAFFIC SIGNAL SECONDARY	2000V.											
				9	RECEPTACLE BRACKET & LAMP POST WIRE	600V.											
				10	2/C 8 AWG UNCOATED SOFT 7/STR. COPPER	600V.											
				11	3/C 350 MCM UNCOATED SOFT PER CONDUCTOR	5000V.											
				12	3/C 2/0 AWG. UNCOATED SOFT PER CONDUCTOR	5000V.											
				13	3/C 350 MCM UNCOATED SOFT PER CONDUCTOR	5000V.											
				14	3/C 350 MCM UNCOATED SOFT PER CONDUCTOR	7000V.											
				15	3/C 2AWG. UNCOATED SOFT PER CONDUCTOR	7000V.											
				16	3/C 350 MCM UNCOATED SOFT PER CONDUCTOR	7000V.											
				17	1/C 8 AWG. UNCOATED SOFT PER CONDUCTOR	7500V.											
				18	1/C 8 AWG. UNCOATED SOFT PER CONDUCTOR	7500V.											
				19	3/C 350 MCM UNCOATED SOFT PER CONDUCTOR	24000V.											
				20	3/C 350 MCM UNCOATED SOFT PER CONDUCTOR	24000V.											
				21	3/C 2/0 AWG. UNCOATED SOFT PER CONDUCTOR	24000V.											
				22	MULTI-SIGNAL CABLE UNCOATED SOFT PER CONDUCTOR												
				23	MULTI-SIGNAL CABLE UNCOATED SOFT PER CONDUCTOR												
				24	8/0 SERIES IN DUCT TINNED COPPER	7500V.											
				25	OVERHEAD FLEXIBLE TRAINER CLASS G OR LARGER, SOFT CONDUCTING												

ACCORDING TO SPECIFICATIONS

ALL MULTIPLE STREET LIGHTING, TRAFFIC SIGNAL SECONDARY AND SPECIAL EVENT CABLES INSTALLED IN CONDUIT SHALL BE AS PER THE FOLLOWING:
 CONDUCTORS: COATED, STRANDED COPPER CONDUCTOR PER ASTM B-8 AND B-189. INSULATION: MEETS OR EXCEEDS ALL REQUIREMENTS OF LATEST EDITION OF ICEA S-68-516, NEMA WC 8 FOR ETHYLENE-PROPYLENE RUBBER INSULATION AND ASTM D2802-78 AND UL STANDARD 44. JACKETS: MEETS OR EXCEEDS ALL REQUIREMENTS OF LATEST EDITION OF ICEA S-68-516, NEMA WC 8 FOR HEAVY DUTY CHLOROSULFONATED-POLYETHYLENE. LISTED BY UNDERWRITERS LABORATORIES INC. AS TYPE RHM OR RHW.
 NOTE: PRIOR TO PLACING ORDER FOR PURCHASE OF THIS CABLE, A SAMPLE LENGTH OF CABLE MUST FIRST BE SUBMITTED TO P.L.D. FOR THEIR APPROVAL.

COLOR CODED AS FOLLOWS:
 RED - A CIRCUIT
 BLACK - B CIRCUIT
 WHITE - NEUTRAL