

APPROVED BY CITY ENGINEERING DEPARTMENT

RECOMMENDED FOR APPROVAL
STRUCTURAL ENGINEER
DATE

RECOMMENDED FOR APPROVAL
ENGINEER OF INSPECTION
DATE

APPROVED
ELMORE M. KENNEDY-DEPUTY DIRECTOR
DATE

APPROVED
CLYDE R. HOPKINS-DIRECTOR
DATE



PREPARED UNDER THE SUPERVISION OF
BHAGU PATEL, P.E. REG. NO. 28263
DATE

CITY OF DETROIT
CITY ENGINEERING DEPARTMENT
COLEMAN A. YOUNG, MAYOR
PLANS FOR PROPOSED
RANDOLPH STREET PEDESTRIAN BRIDGE
FOR
DEPARTMENT OF PUBLIC WORKS
CITY BRIDGE NO. BP-27
CONSULTANT PROJECT NO. 8612



CIVIL

C-1 SITE PLAN
1-1 TRAFFIC CONTROL PLAN-STAGE 1
1-2 TRAFFIC CONTROL PLAN-STAGE 2
1-3 TRAFFIC CONTROL PLAN-STAGE 3
1-4 TRAFFIC CONTROL PLAN-STAGE 4

ARCHITECTURAL

A-1 GENERAL PLAN OF STRUCTURE
A-2 GENERAL PROFILE OF STRUCTURE AND ELEVATION
A-3 SECTIONS AND ELEVATIONS
A-4 FENCING GRILLAGE DETAILS
A-5 PANEL DETAILS
A-6 PANEL DETAILS

STRUCTURAL

S-1 PIER 1 DETAILS
S-2 PIER 2 DETAILS
S-3 PIER 3 DETAILS
S-4 PIER 4 DETAILS
S-5 PIER 4 DETAILS
S-6 STRUCTURAL STEEL DETAILS
S-7 STRUCTURAL STEEL DETAILS
S-8 STRUCTURAL STEEL DETAILS
S-9 SUPERSTRUCTURE AND STRUCTURAL STEEL DETAILS
S-10 BEARING DETAILS
S-11 DECK DRAIN DETAILS
S-12 STRUCTURAL STEEL DETAILS
S-13 DECK DRAIN DETAILS
S-14 RENAISSANCE PLAZA RECONSTRUCTION DETAILS
S-15 RENAISSANCE PLAZA RECONSTRUCTION DETAILS
S-16 RENAISSANCE PLAZA RECONSTRUCTION DETAILS
S-17 RENAISSANCE PLAZA RECONSTRUCTION DETAILS
S-18 RENAISSANCE PLAZA RECONSTRUCTION DETAILS
S-19 JOINT DETAILS
S-20 SOIL BORING LOG SHEET

ELECTRICAL

E-1 ELECTRICAL SITE PLAN
E-2 NOTES AND DETAILS
E-3 DETAILS
E-4 ELECTRICAL WIRING DIAGRAM

INDEX OF DRAWINGS

REVISION	DATE

SIGN LEGEND

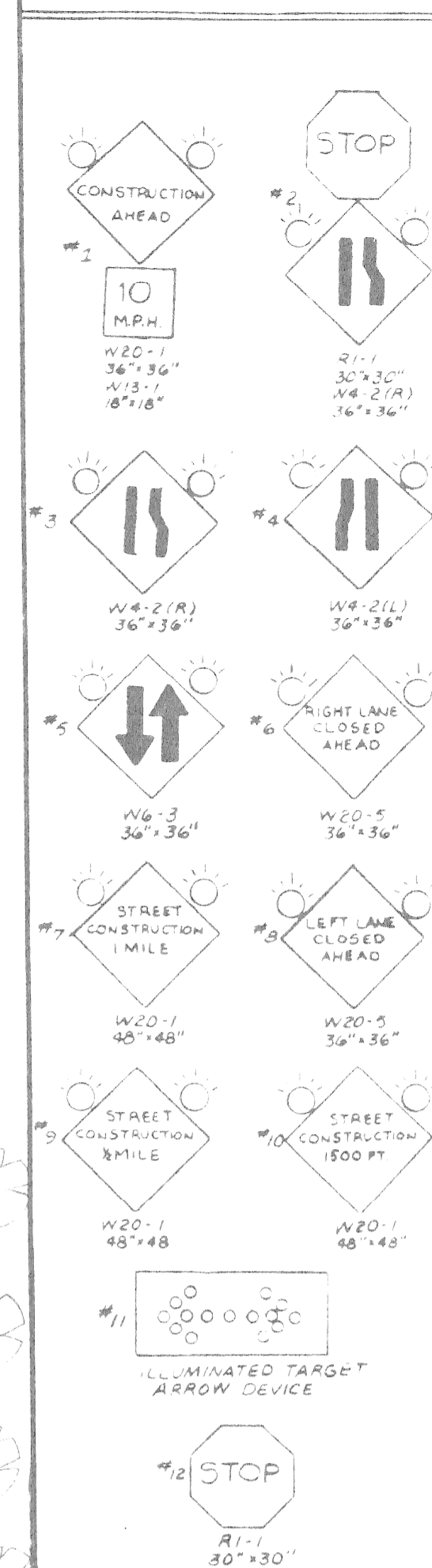

REVISIONS:
 DATE: _____
 BY: _____
 FOR: _____

CITY OF DETROIT
 CITY ENGINEERING DEPARTMENT
 CITY BRIDGE No. **BP-27**

Project: **MADISON INTERNATIONAL OF MICHIGAN**
 Sheet Title: **RANDOLPH STREET PEDESTRIAN BRIDGE TRAFFIC CONTROL PLAN-STAGE 4 PLACING OF GIRDERS**

Engineers: Architects, Planners
 1420 Washington Blvd.
 Detroit, Michigan 48226

DESIGN BY: **K.B.U.**
 DRAWN BY: **K.B.U.**
 CHECKED BY: **R.M.A.**
 DATE: **11-6-89**
 PROJECT NO: **8612**
 SHEET NO: **T-4**

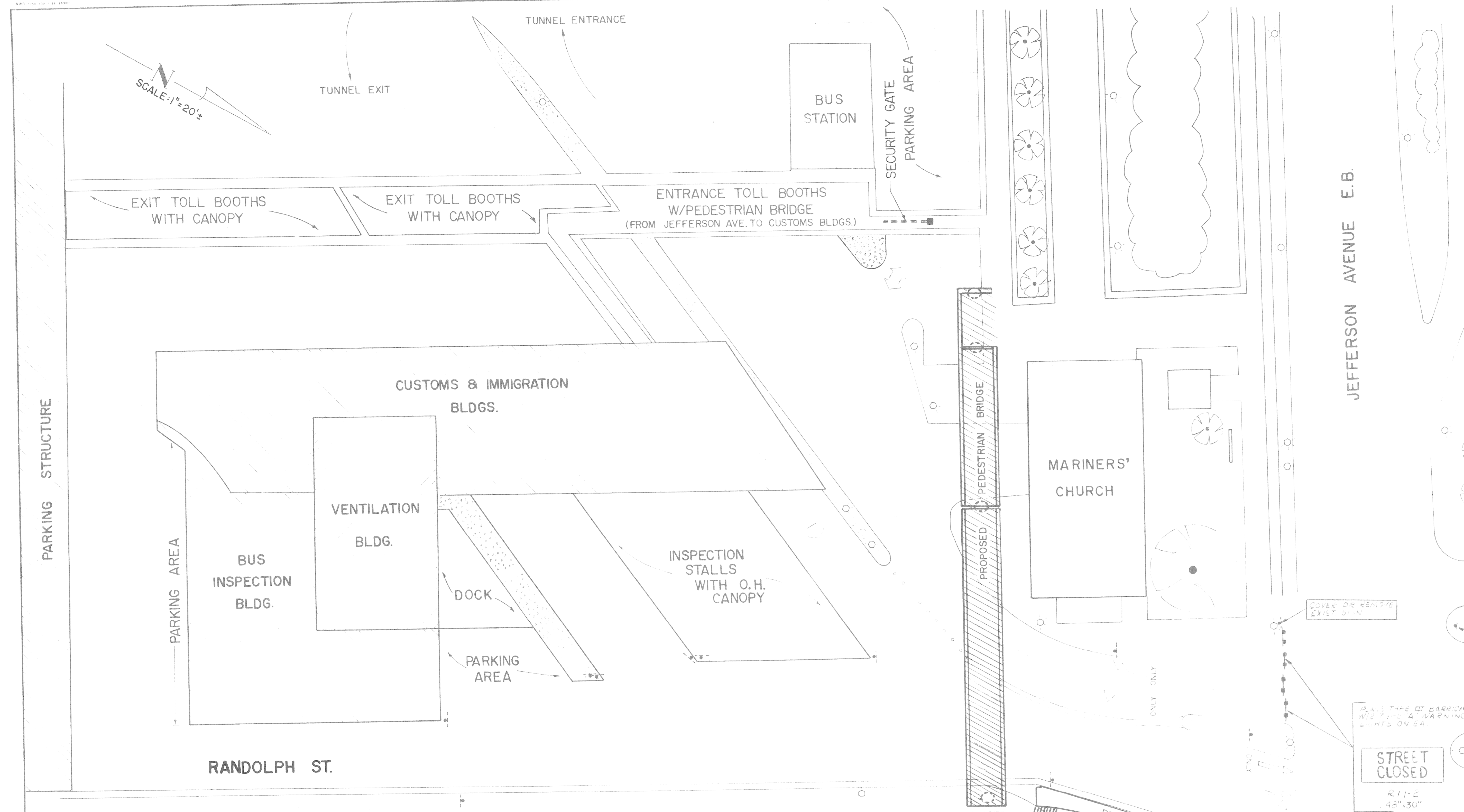

- GENERAL NOTES:**
- TRAFFIC SHALL BE MAINTAINED BY THE CONTRACTOR IN ACCORDANCE WITH THE MICHIGAN MANUAL OF UNIFORM TRAFFIC CONTROL DEVICES AND THE MICHIGAN DEPARTMENT OF TRANSPORTATION'S STANDARD SPECIFICATIONS FOR HIGHWAY CONSTRUCTION.
 - DRAWING IS FOR TRAFFIC CONTROL AND GENERAL REFERENCE ONLY AND NOT FOR SCALING PURPOSES.
 - ALL WORK SHOULD BE DONE DURING WEEKDAY DURING NON-RUSH HOURS. THESE HOURS ARE TO BE COORDINATED BETWEEN DETROIT AND CANADA TUNNEL CORPORATION OFFICIALS, CUSTOMS OFFICIALS, CITY OFFICIALS AND THE CONTRACTOR.
 - TUNNEL SHALL BE CLOSED DURING OPERATION OF PLACING GIRDERS WHICH CROSSES RANDOLPH STREET. THIS OPERATION SHALL BE DONE AT NIGHT AND IS TO BE COORDINATED BETWEEN CUSTOMS OFFICIALS, DETROIT AND CANADA TUNNEL CORPORATION OFFICIALS, CITY OFFICIALS AND THE CONTRACTOR. TUNNEL CAN BE CLOSED FOR A HALF AN HOUR (1/2 HOUR) MAXIMUM.
 - ONLY PERTINENT, EXISTING TRAFFIC CONTROL SIGNS ARE SHOWN ON THIS PLAN.
 - EACH TRAFFIC CONTROL STAGE CORRESPONDS WITH THE CONSTRUCTION OF THE CROSS-HATCHED PIERS, RAMPS, STAIRS OR GIRDERS.
 - TRAFFIC CONTROL STAGES ONLY SUGGEST ORDER OF CONSTRUCTION. ACTUAL ORDER OF CONSTRUCTION IS TO BE COORDINATED BETWEEN CUSTOMS OFFICIALS, DETROIT AND CANADA TUNNEL CORPORATION OFFICIALS, CITY OFFICIALS AND THE CONTRACTOR. NUMERICAL ORDER OF TRAFFIC CONTROL STAGES SHOULD ORANGE ACCORDINGLY.
 - THE MAXIMUM SPACING BETWEEN CHANNELIZING DEVICES SHOULD BE APPROXIMATELY EQUAL IN FEET TO THE SPEED LIMIT PER MICHIGAN UNIFORM TRAFFIC CONTROL STANDARDS.
 - PAVEMENT MARKINGS NO LONGER APPLICABLE WHICH MIGHT CREATE CONFUSION IN THE MINDS OF VEHICLE OPERATORS SHALL BE REMOVED OR OBLITERATED AS SOON AS PRACTICABLE, AND REPAIRED AFTER BRIDGE CONSTRUCTION IS COMPLETED. TEMPORARY MARKINGS SHALL BE USED AS SHOWN ON THE DRAWINGS.
 - EXISTING SIGNS NO LONGER APPLICABLE SHALL BE COVERED OR REMOVED AND UNCOVERED OR REPLACED PRIOR TO THE START OF THE NEXT TRAFFIC CONTROL STAGE.
 - GATE LOCATED AT TOP OF EXISTING STAIRS WEST OF RENAISSANCE CENTER BERM SHOULD BE USED TO STOP PEDESTRIANS FROM USING THESE STAIRS AT THE DISCRETION OF THE CONTRACTOR. PERMISSION IS TO BE COORDINATED BETWEEN RENAISSANCE CENTER OFFICIALS AND THE CONTRACTOR.
 - NO STANDING ON RENAISSANCE DRIVE, BY VEHICLES, SHALL BE ENFORCED AT AREAS CONCERNED DURING TRAFFIC CONTROL.

EXISTING STANDARDS NOTES:

- EXISTING SIGNAGE SHALL BE 2' HIGH X 10' WIDE OR PLACED AT TUNNEL ENTRANCE IN CANADA PRIOR TO THE TIME THE TUNNEL IS CLOSED AND MAINTAINING OF TIME IS TO BE COORDINATED BETWEEN DETROIT AND CANADA TUNNEL CORPORATION OFFICIALS. EXISTING SIGNAGE SHALL BE 2' HIGH X 10' WIDE.

EXISTING	DESCRIPTION	SYMBOL	REQUIRED	DESCRIPTION
○	LIGHT POLE	○	○	PIER
+	TRAFFIC SIGN	+	+	TRAFFIC SIGN
□	TRUCK	□	□	ILLUMINATED ARROW PANEL
○	PAVEMENT ISLAND	○	○	GLAZED BIRMS PLACED AT 10 FT INTERVALS
→	PAVEMENT MARKING	→	→	10 FT IMPACT GEMSTONE BARRIER
→	VEHICLE PAINT	→	→	VEHICLE PAINT DURING CONSTRUCTION
→		→	→	DOUBLE YELLOW TEMPORARY MARKINGS
→		→	→	SINGLE YELLOW (REMOVED) TEMPORARY MARKINGS
→		→	→	SINGLE YELLOW (OPTION) TEMPORARY MARKINGS
→		→	→	TYPE II IMPROVEDS
→		→	→	TYPE III IMPROVEDS
→		→	→	SOLID WHITE MARKING

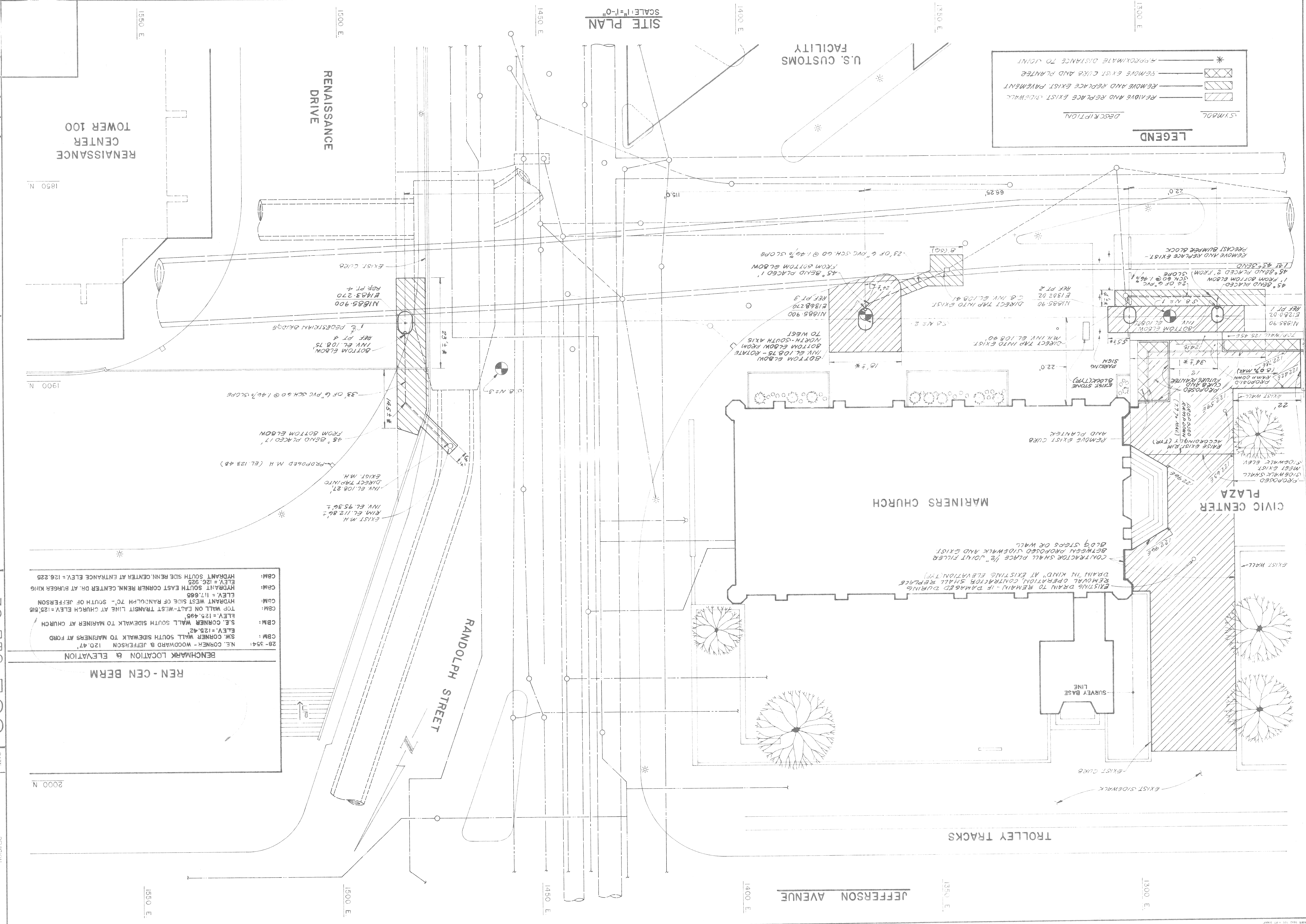

1850 N.
 1900 N.
 1950 N.
 2000 N.

SCALE: 1"=10'

PLAN

A-1
SHEET NO.
8612
PROJECT NO.
NOVEMBER, 1979
DATE

DESIGN BY
R.J.C./K.C.H.
DRAWN BY
K.C.H.
CHECKED BY
F.A.

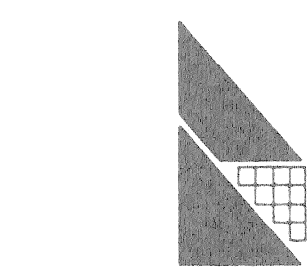

MADISON INTERNATIONAL OF MICHIGAN
Engineers, Architects, Planners
Detroit, Michigan 48226

Project
Sheet Title
RANDOLPH STREET
PEDESTRIAN BRIDGE
GENERAL PLAN OF STRUCTURE

CITY OF DETROIT
CITY ENGINEERING DEPARTMENT
CITY BRIDGE NO. BP-27

REVISION
DATE
NOV. 28 1979
BY
R.J.C./K.C.H.
CHECKED BY
F.A.

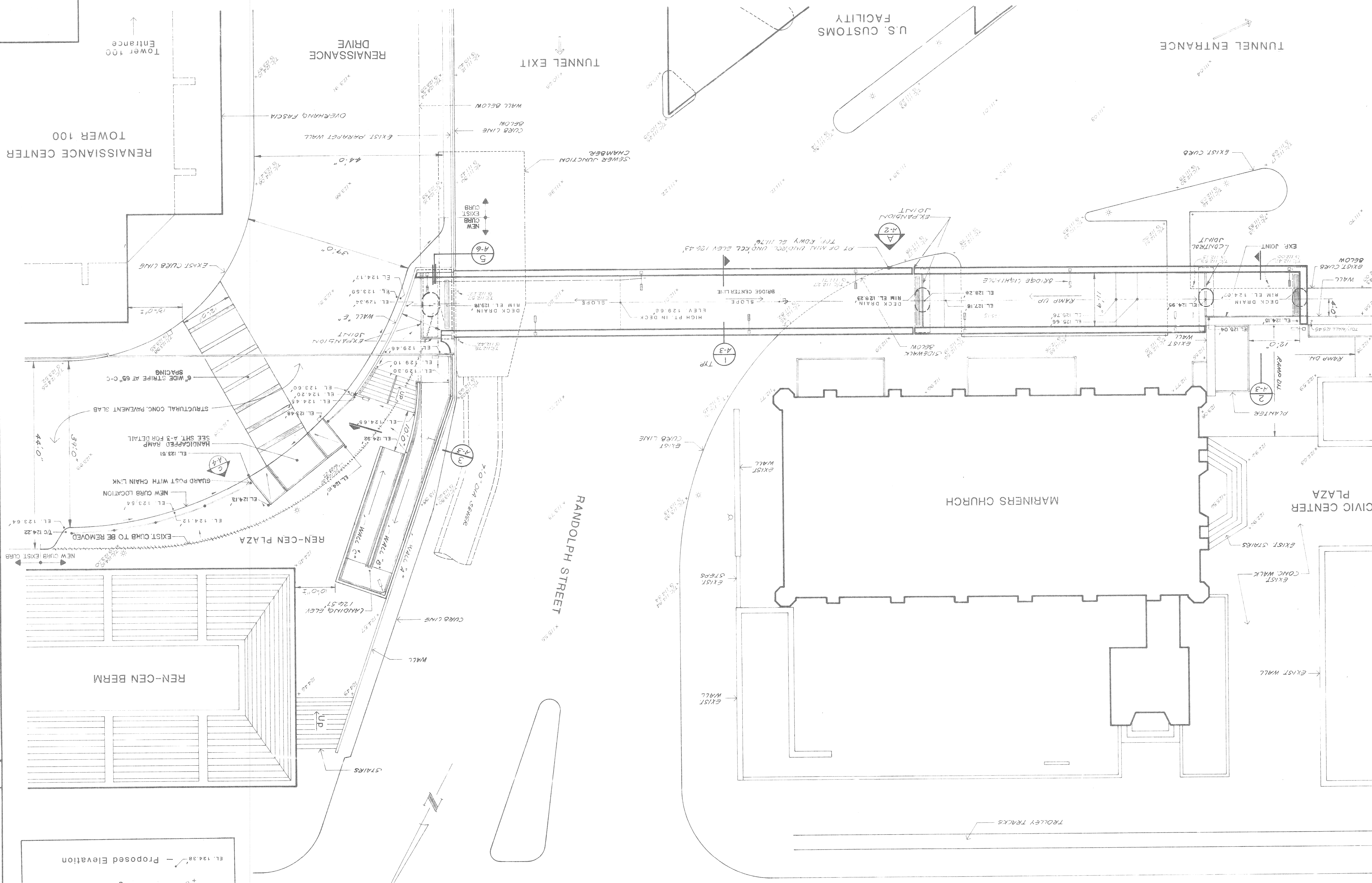

LEGEND
- Existing Elevation
- Proposed Elevation

DESIGN BY
KCH/PDA

DRAWN BY
KCH/PDA

CHECKED BY
KCH/PDA

DATE
NOVEMBER, 89

PROJECT NO.
8612

SHEET NO.
A-2

MADISON MADISON
INTERNATIONAL OF MICHIGAN
Engineers, Architects, Planners
Detroit, Michigan 48226

Project
**RANDOLPH STREET
PEDESTRIAN BRIDGE**

Sheet Title
**GENERAL PROFILE OF STRUCTURE
AND ELEVATION**

CITY OF
DETROIT

CITY
ENGINEERING
DEPARTMENT

CITY BRIDGE
No. BP-27

REVISION	DATE
SCALE: 1" = 10'	NOV 89
SCALE: 1" = 10'	NOV 89
SCALE: 1" = 10'	NOV 89
SCALE: 1" = 10'	NOV 89

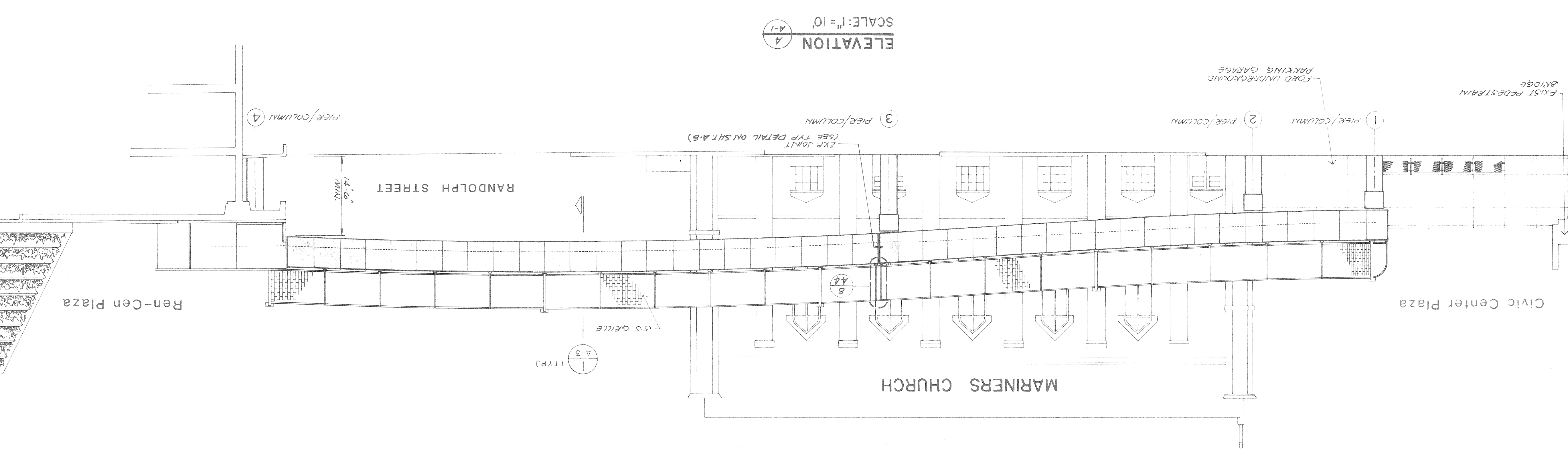
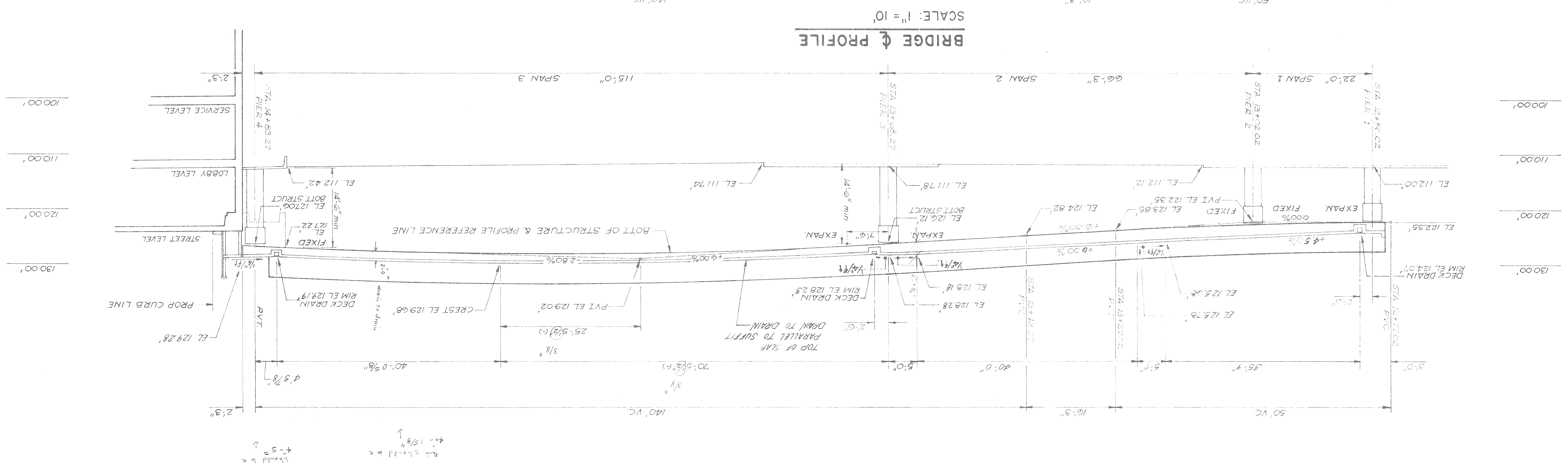

CIVIC CENTER PLAZA
 REN-CEN PLAZA
 MARINERS CHURCH
 RANDOLPH STREET
 EXIST. PEDESTRIAN BRIDGE
 FORD UNDERGROUND PARKING GARAGE
 SCALE: 1" = 10'
 ELEVATION A
 SCALE: 1" = 10'
 PROFILE REFERENCE LINE/SOFT LINE
 SCALE: 1" = 10'

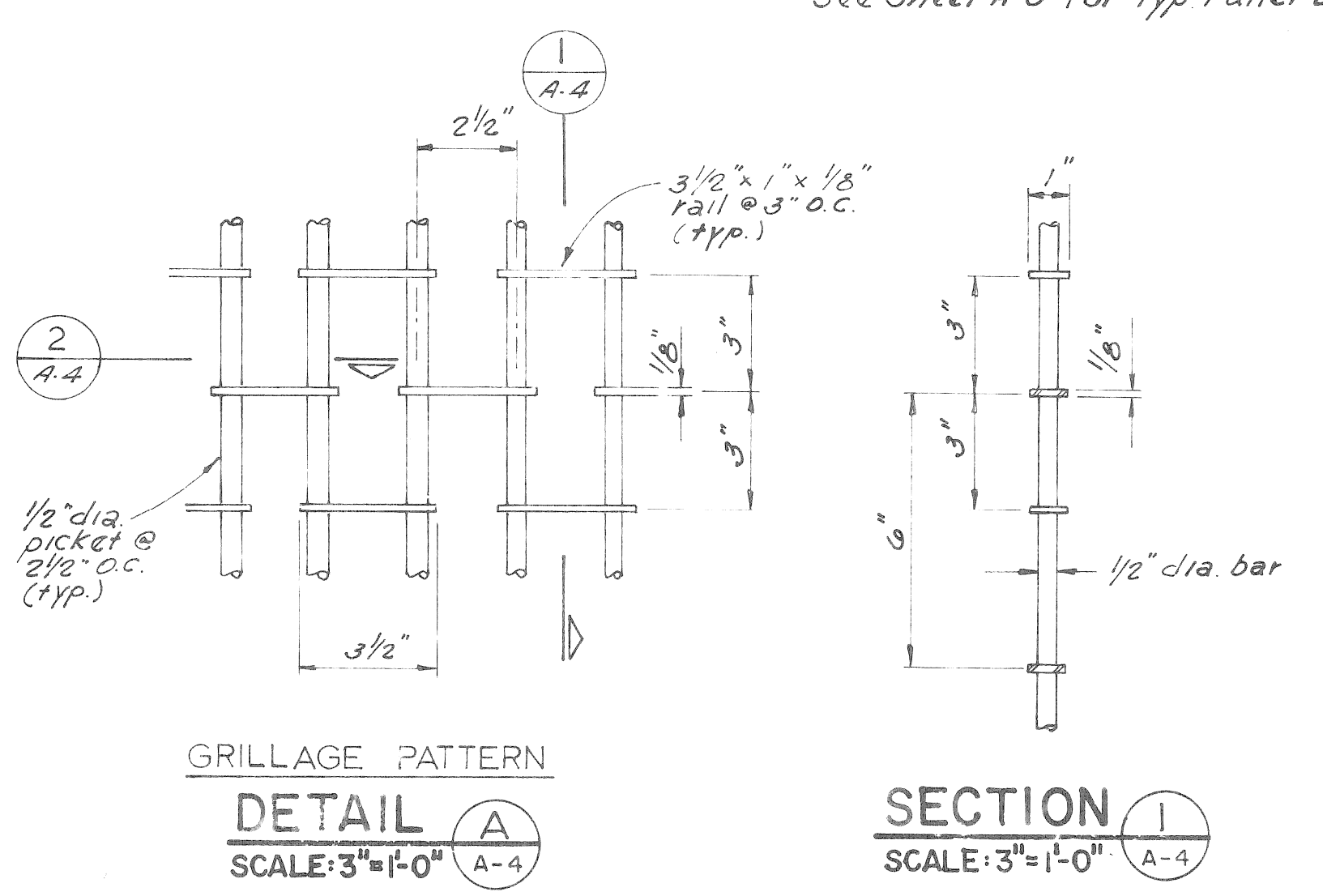
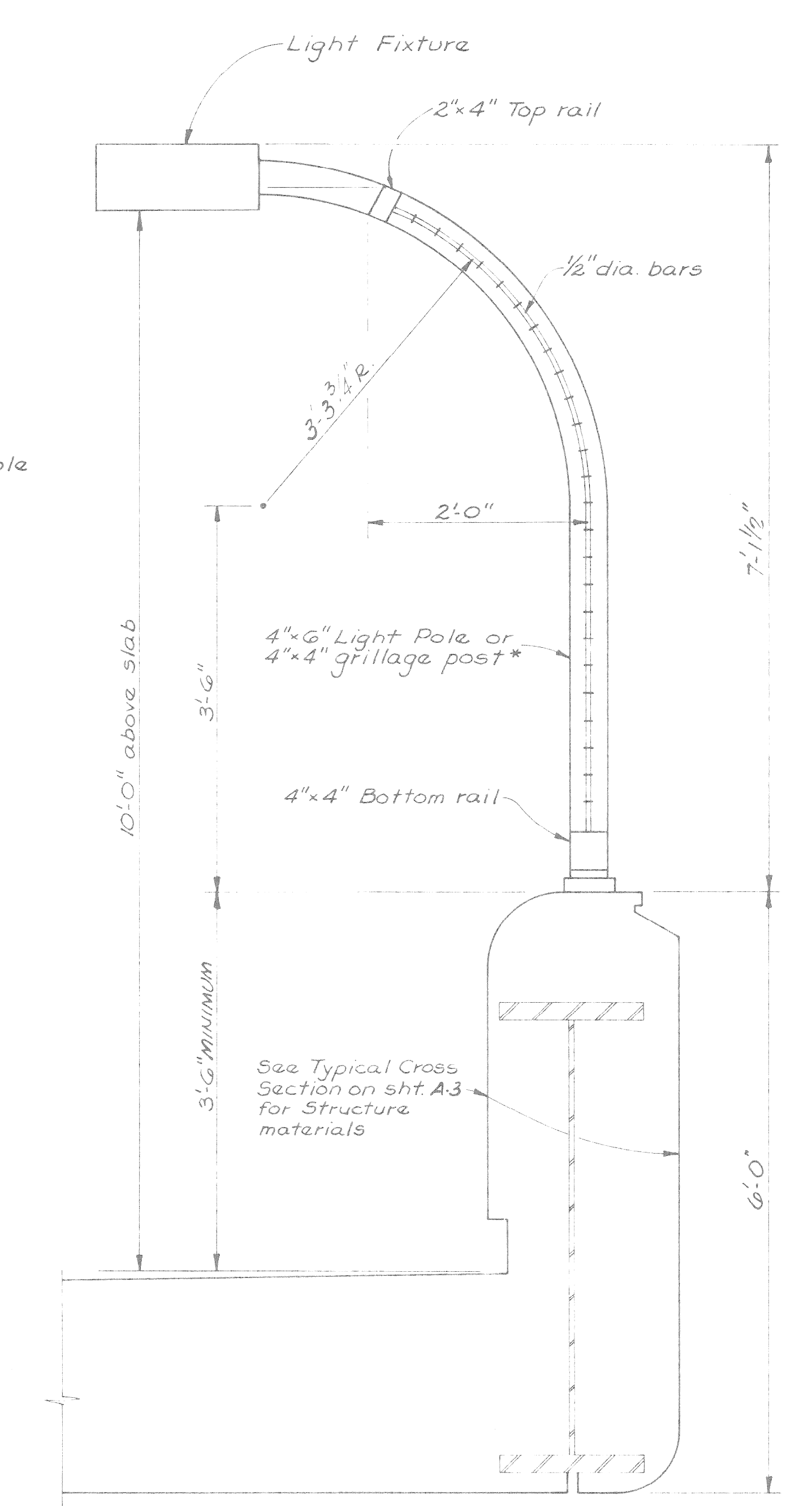
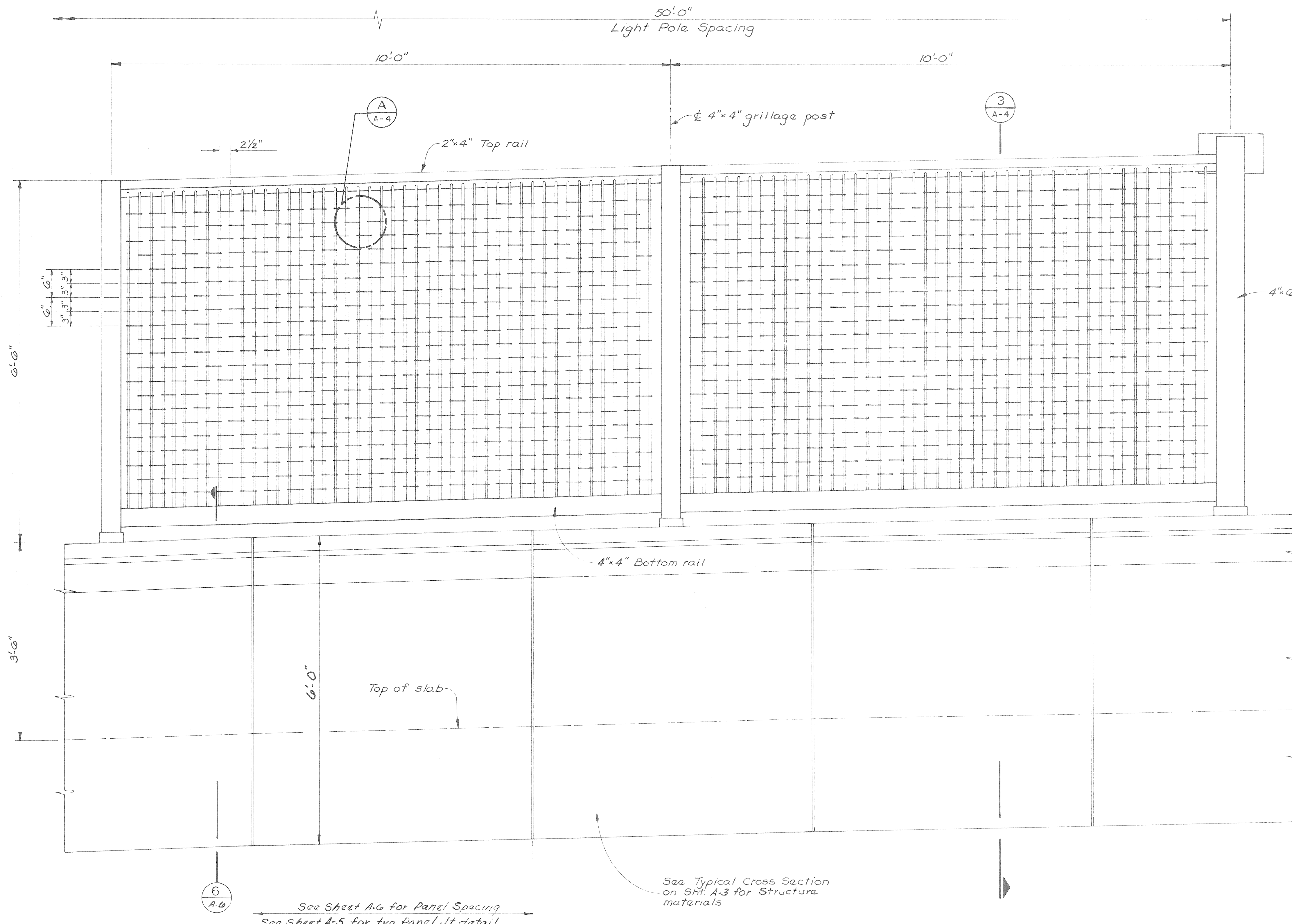

TYPICAL PARTIAL ELEVATION
SCALE: 1"=1'-0"

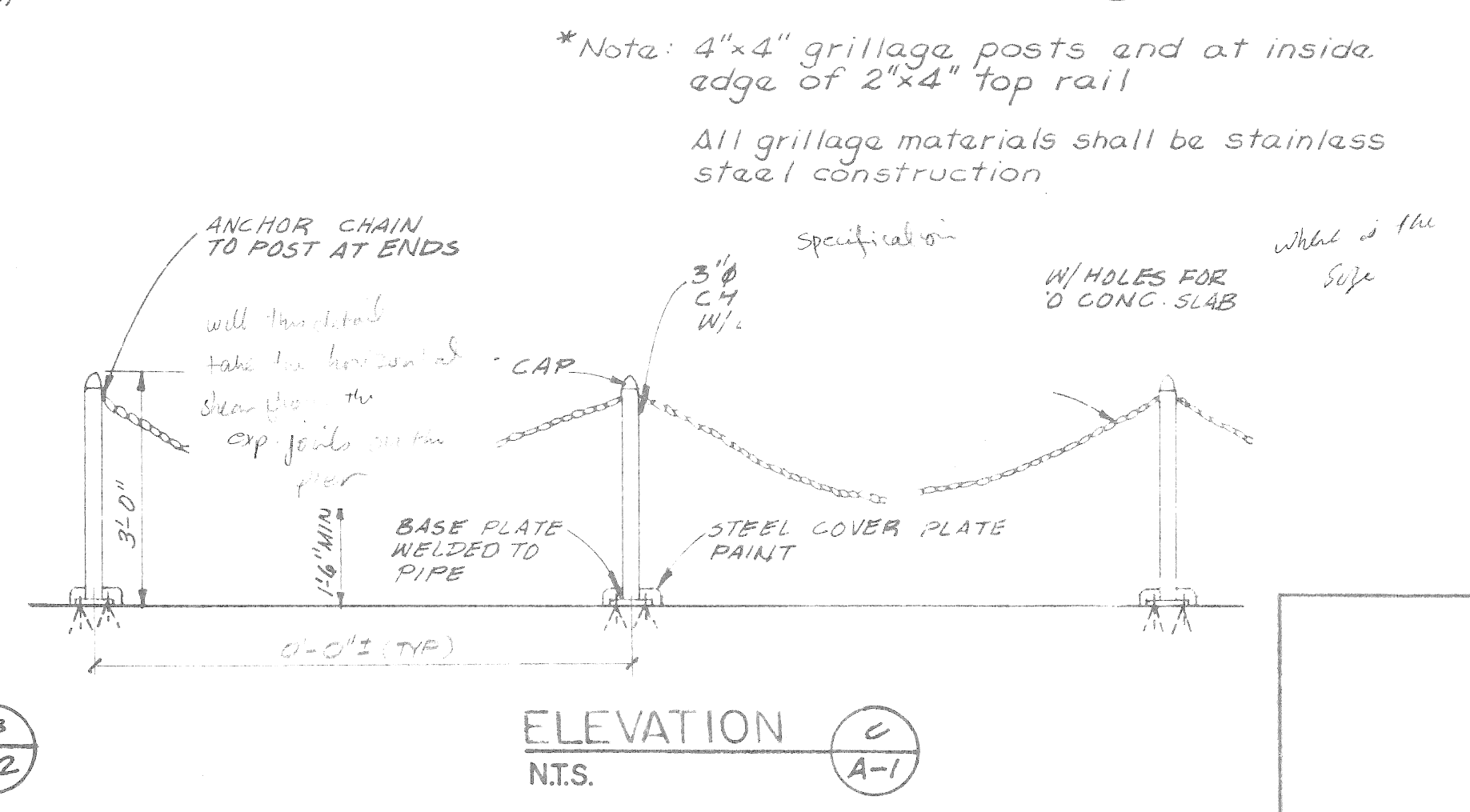
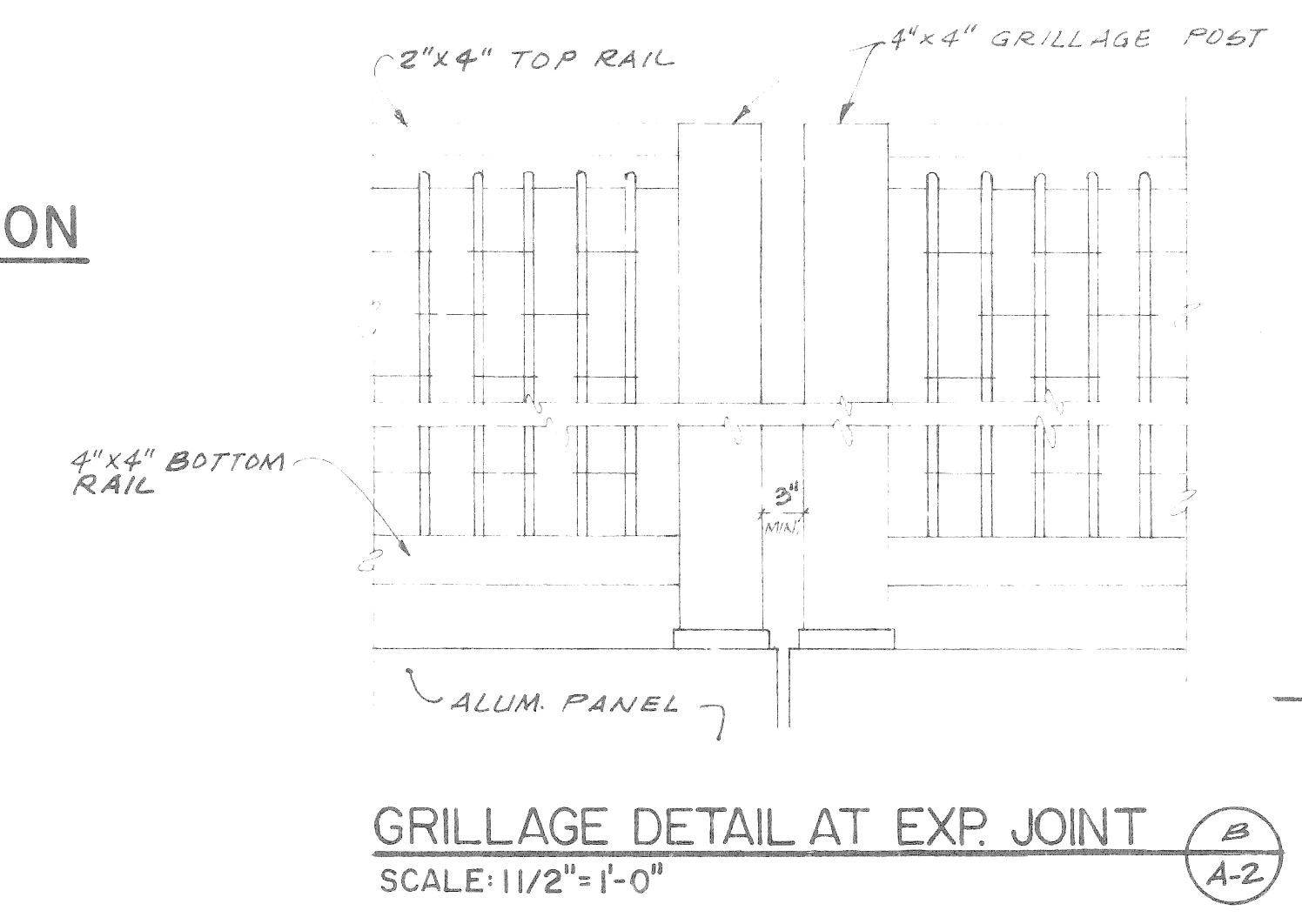

*Note: 4"x4" grillage posts and at inside edge of 2"x4" top rail

All grillage materials shall be stainless steel construction.

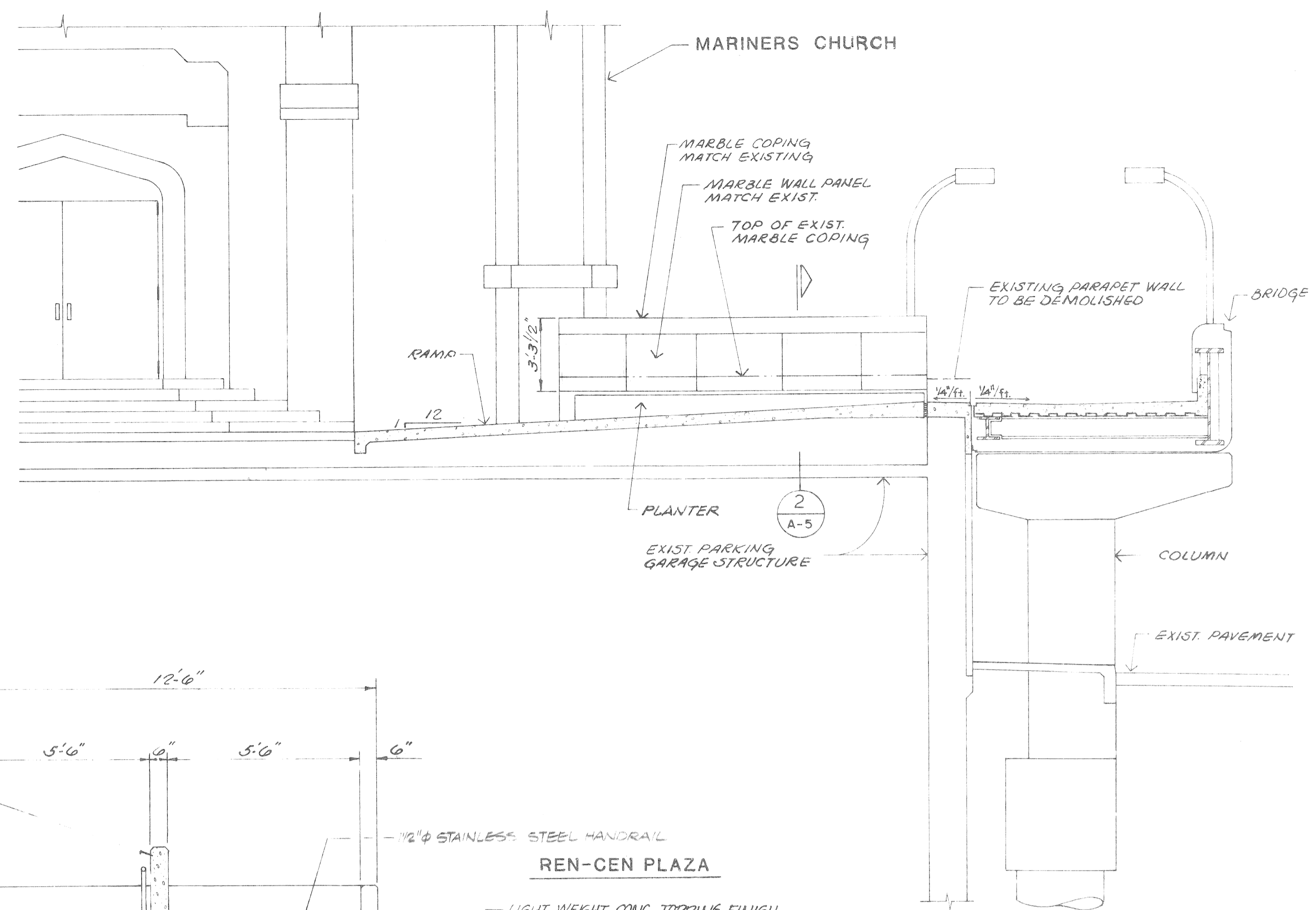

SECTION 2
SCALE: 1/4" = 1'-0"
A-1

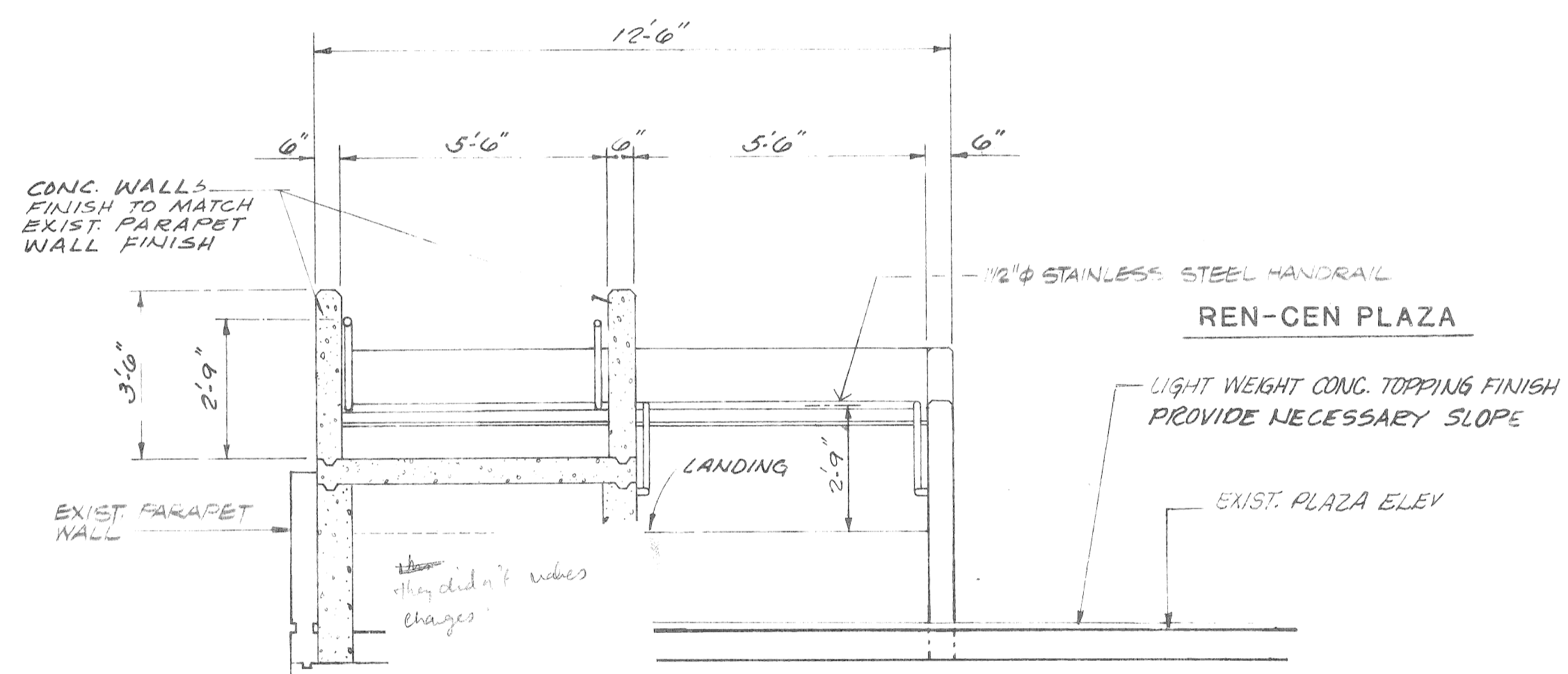

SECTION 3
SCALE: 3/8" = 1'-0"
A-1

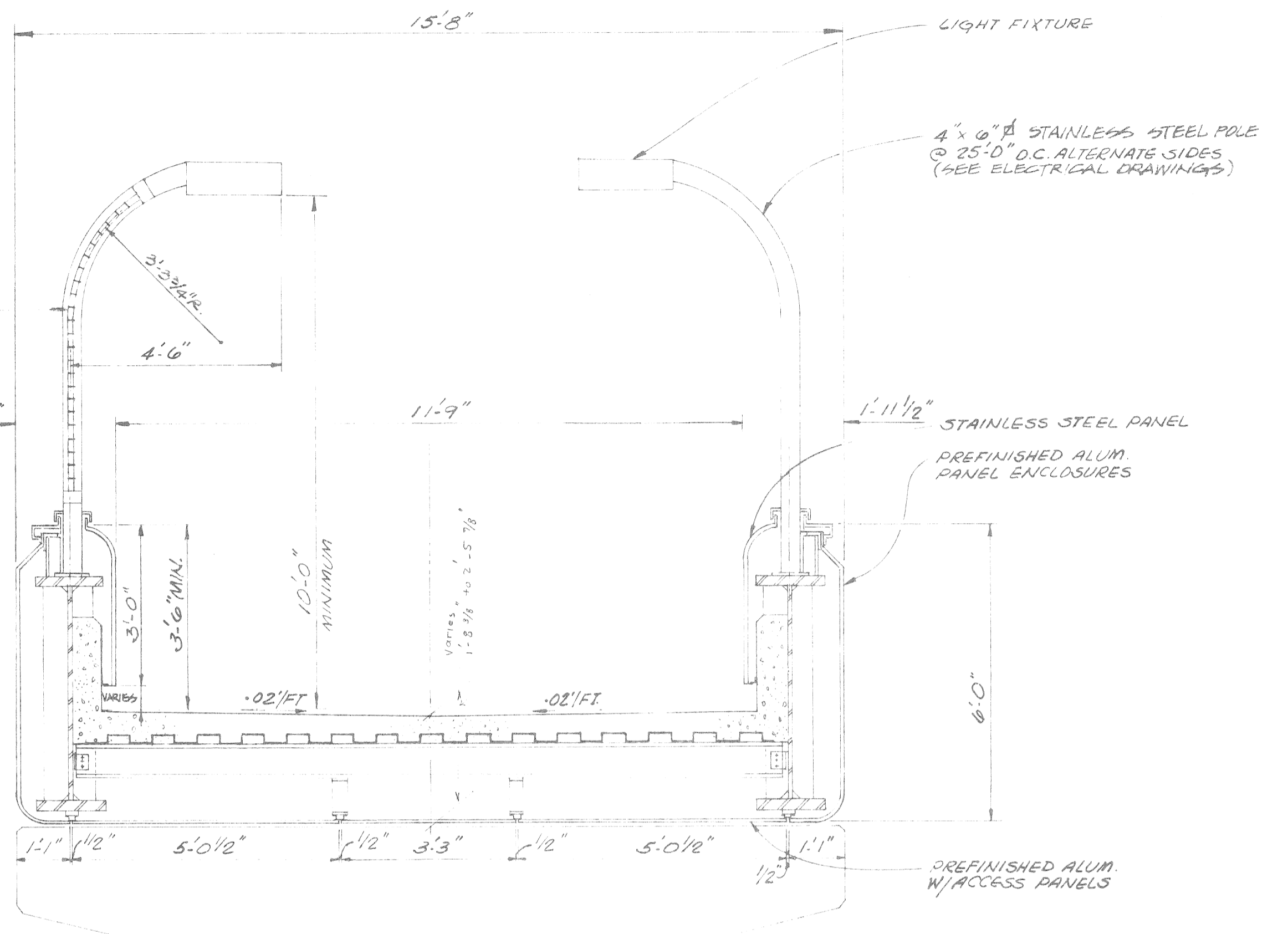

TYPICAL CROSS-SECTION 1
SCALE: 1/2" = 1'-0"
A-1, A-2

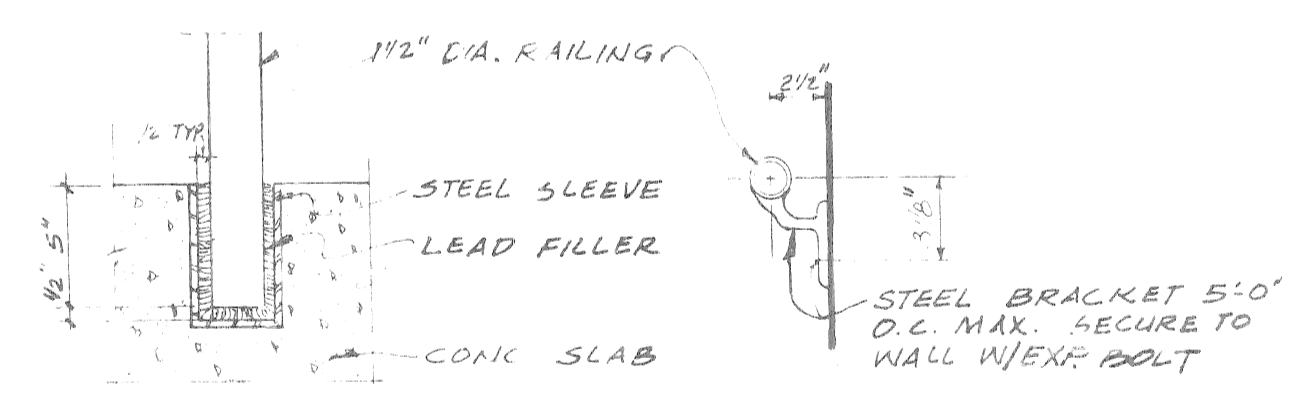

RAILING SETTING
N.T.S.

WALL BRACKET
SCALE: 1 1/2" = 1'-0"

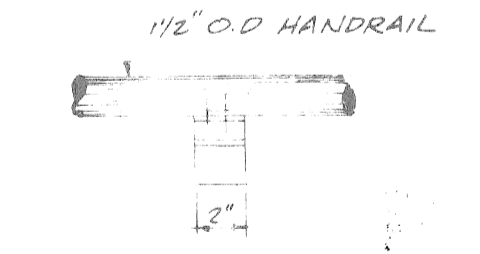

WALL BRACKET
SCALE: 1 1/2" = 1'-0"

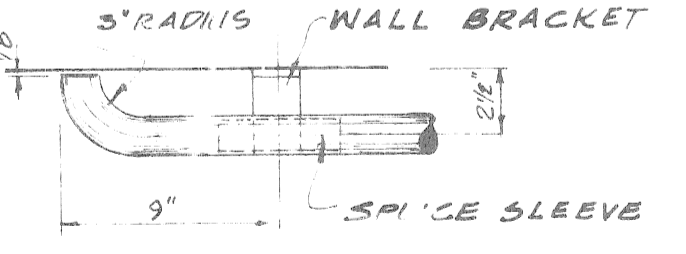

WALL END RETURN
SCALE: 1 1/2" = 1'-0"

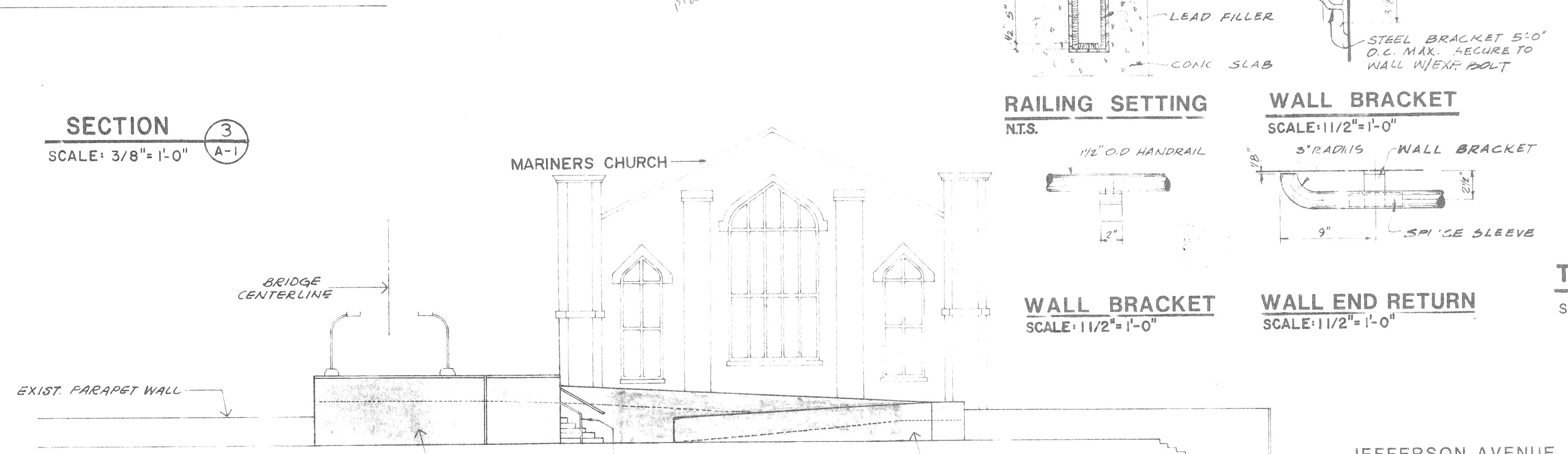

ELEVATION AT REN-CEN PLAZA
SCALE: 1" = 10'

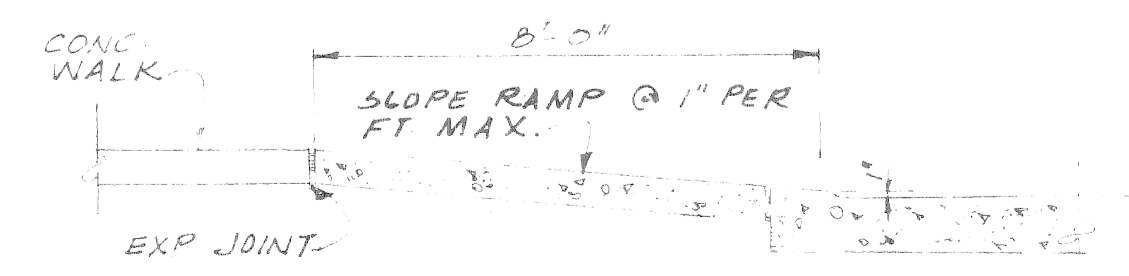

SECTION-HANDICAPPED RAMP
N.T.S.

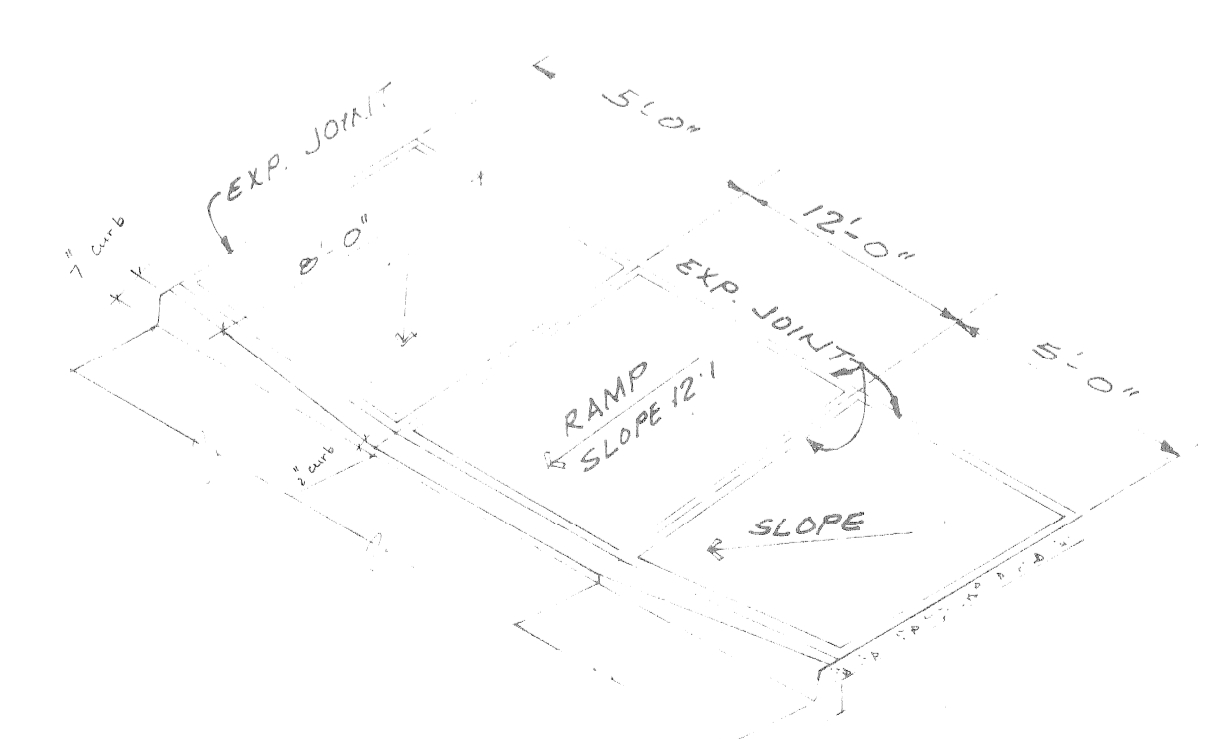

DETAIL - HANDICAPPED RAMP
N.T.S.

- NOTE:**
- 1) ALL EXPOSED CONCRETE WALL FINISH SHALL MATCH EXISTING PARAPET WALL FINISH.
 - 2) APPLY NON-SLIP BROOM FINISH TO HANDICAPPED RAMP SURFACES.

REVISIONS	DATE	BY	APP'D

CITY OF DETROIT
CITY ENGINEERING DEPARTMENT
CITY BRIDGE No. BP-27

RANDOLPH STREET PEDESTRIAN BRIDGE
SECTIONS AND ELEVATION

MADISON MADISON INTERNATIONAL OF MICHIGAN
Engineers, Architects, Planners
Detroit, Michigan 48226

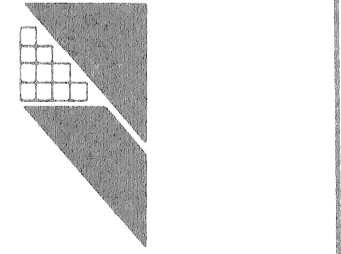

DESIGN BY
KCH, SO, D.L.M.
DRAWN BY
KCH/POA
CHECKED BY
PA

DATE
NOVEMBER, 89
PROJECT NO.
8612
SHEET NO.
A-3

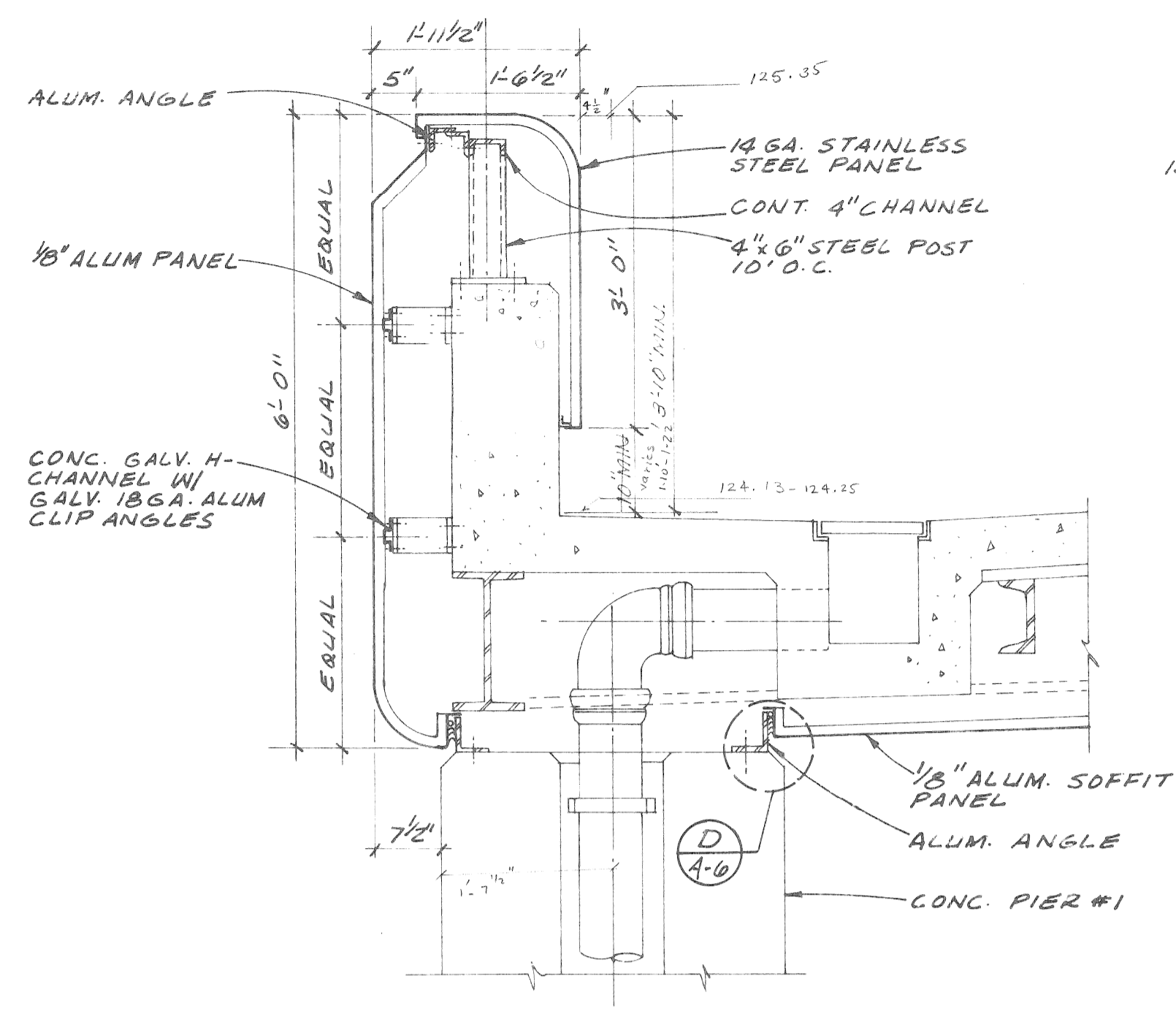

SECTION 4
SCALE: 3/4" = 1'-0" A-5

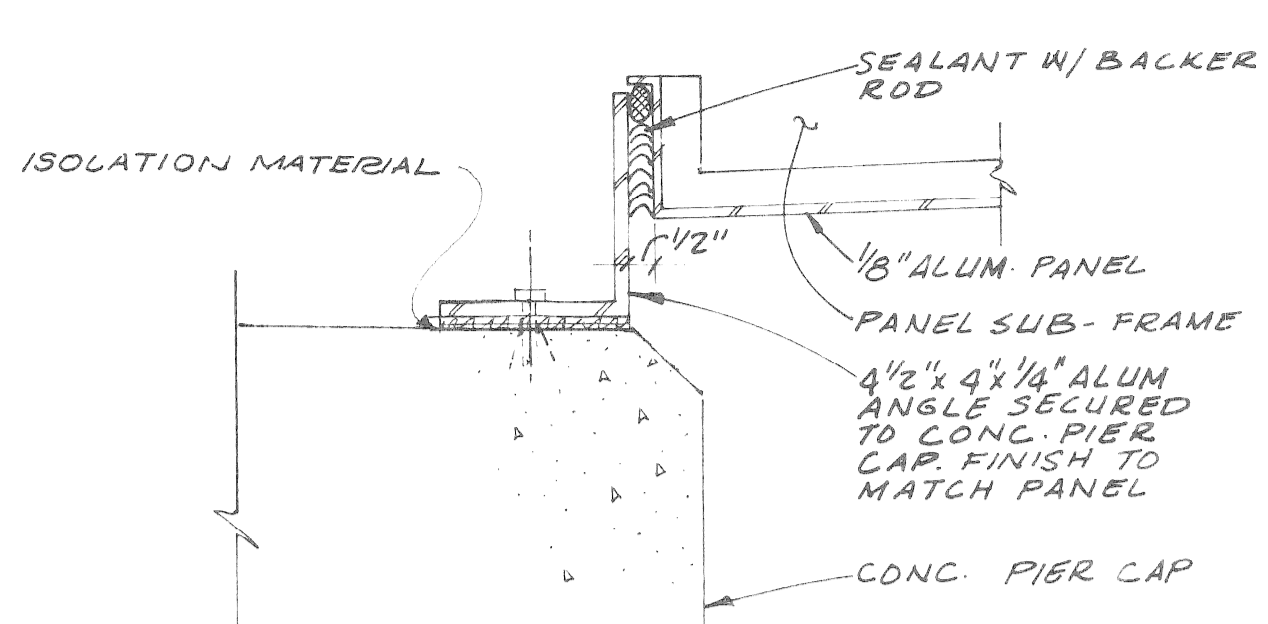

DETAIL D
SCALE: 3" = 1'-0" A-6

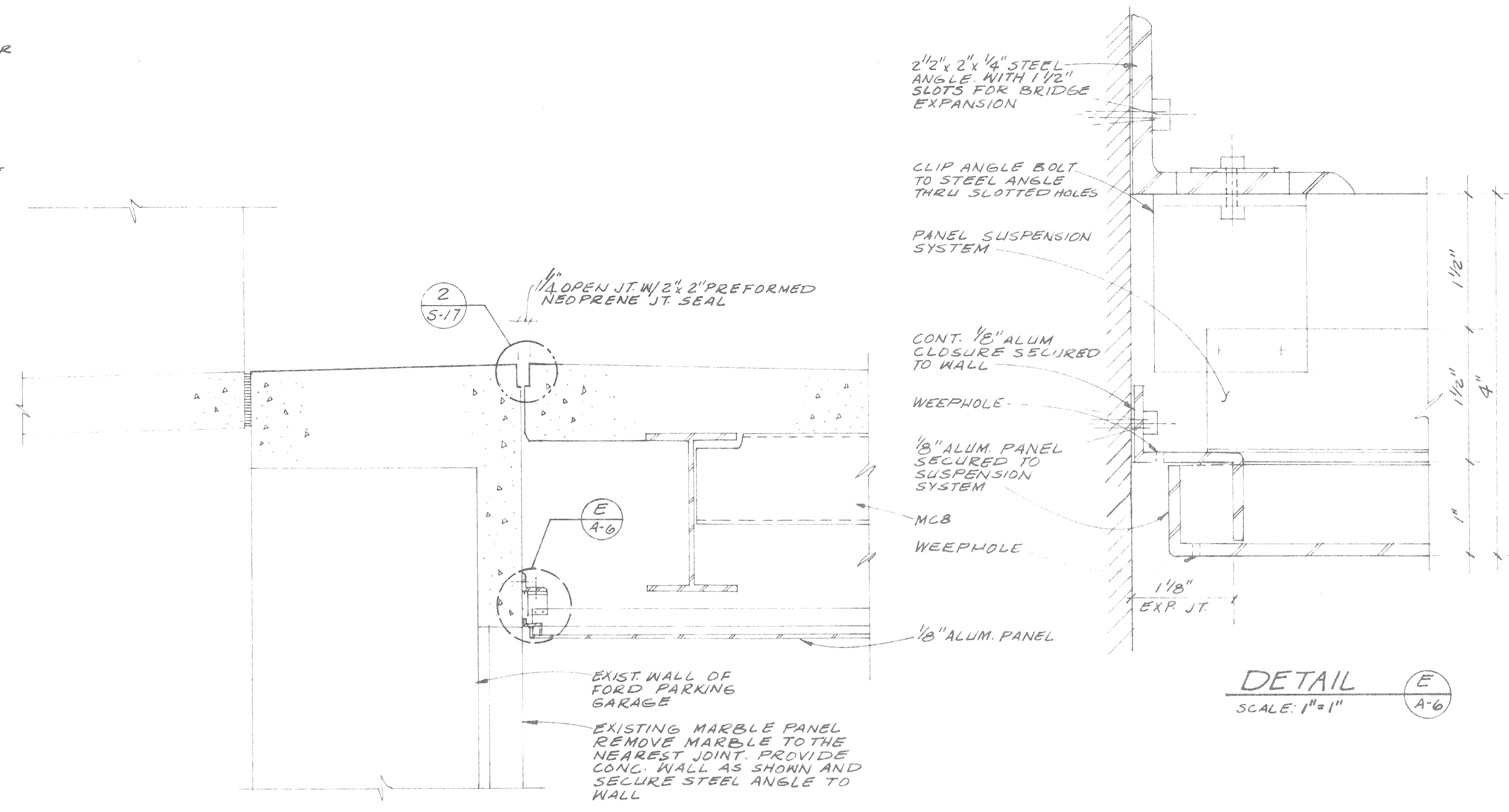

DETAIL E
SCALE: 1" = 1" A-6

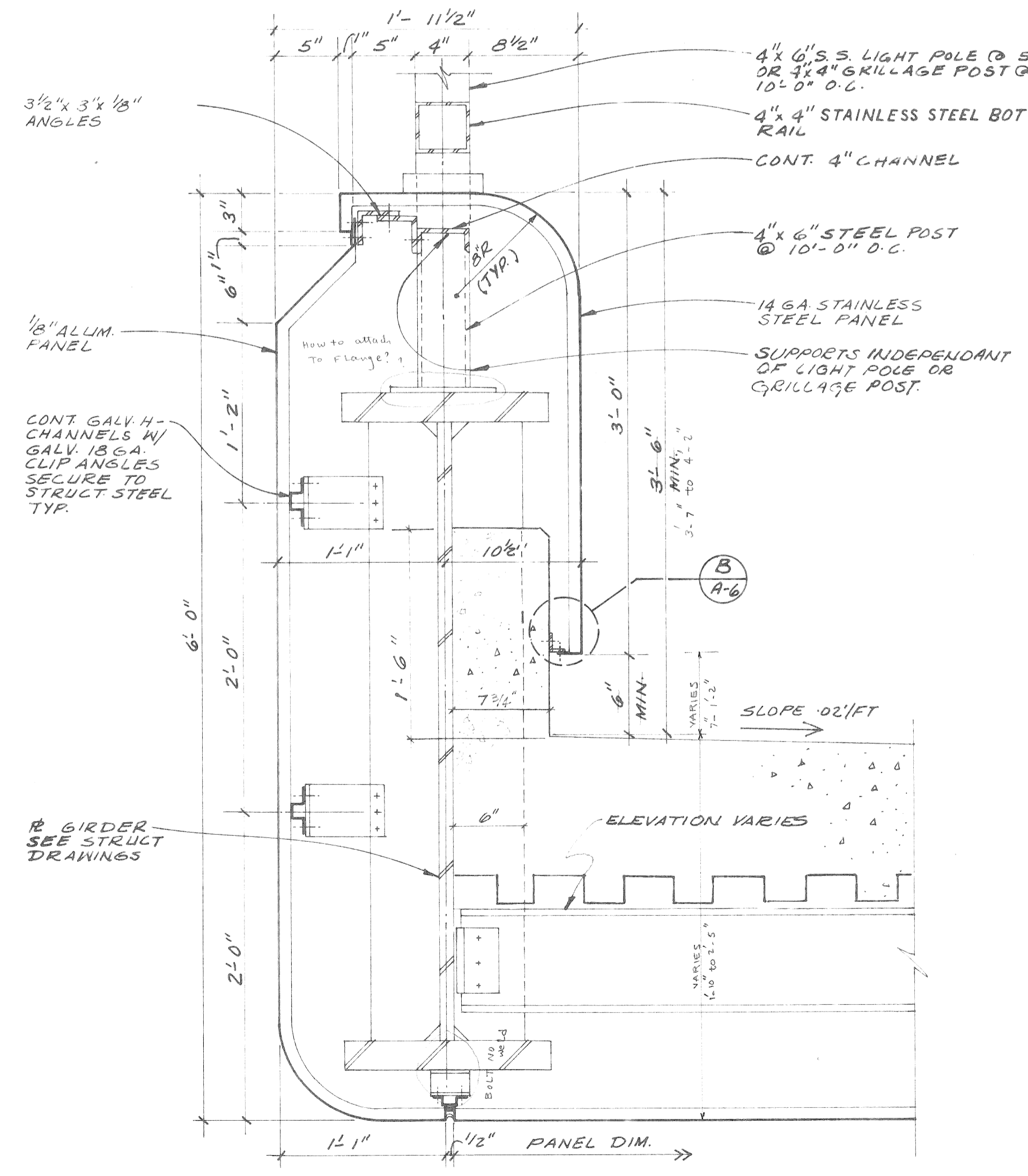

SECTION 6
SCALE: 1/2" = 1'-0" A-4

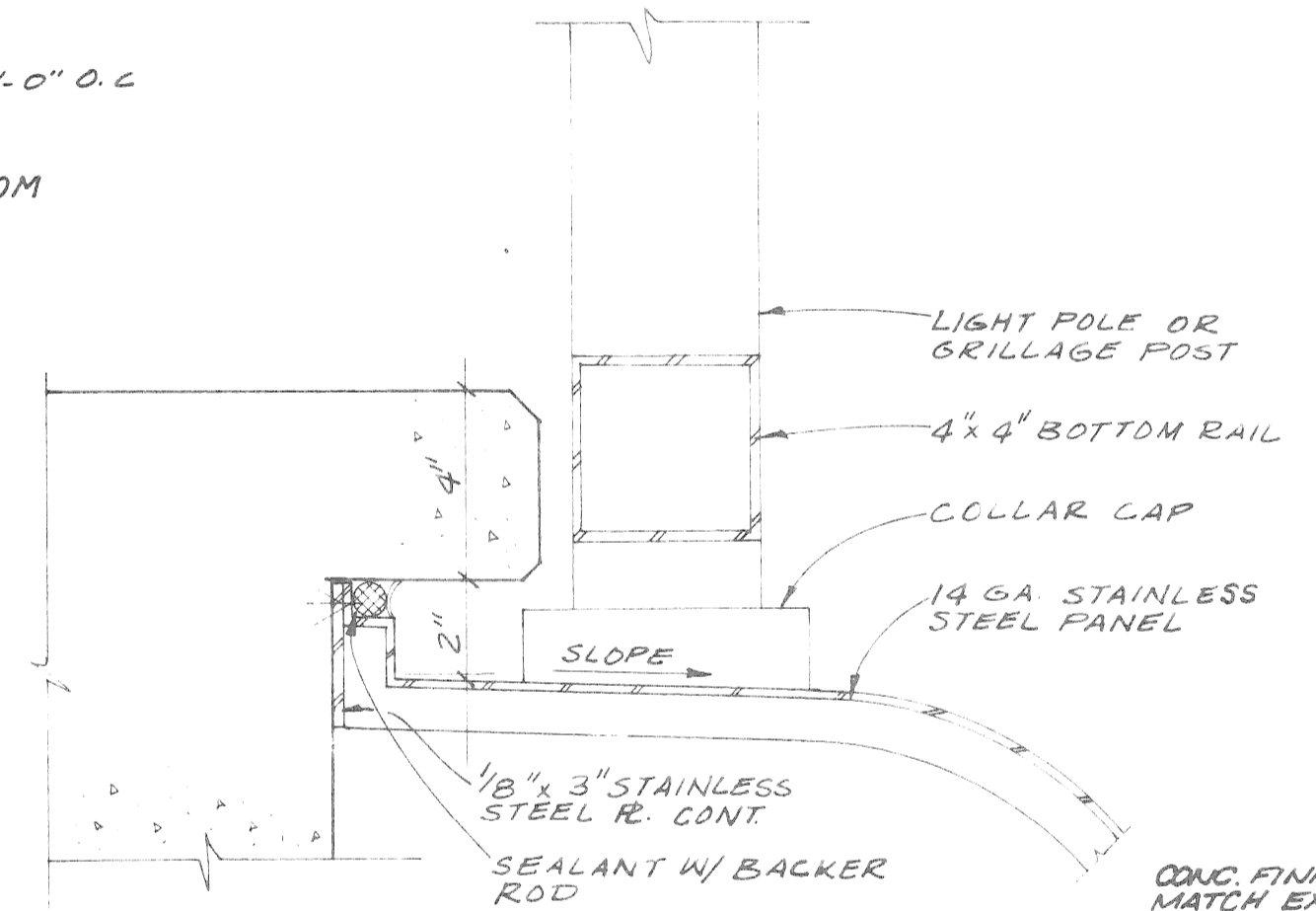

DETAIL C
SCALE: 3" = 1'-0" A-6

SECTION 3
SCALE: 1/2" = 1'-0" A-5

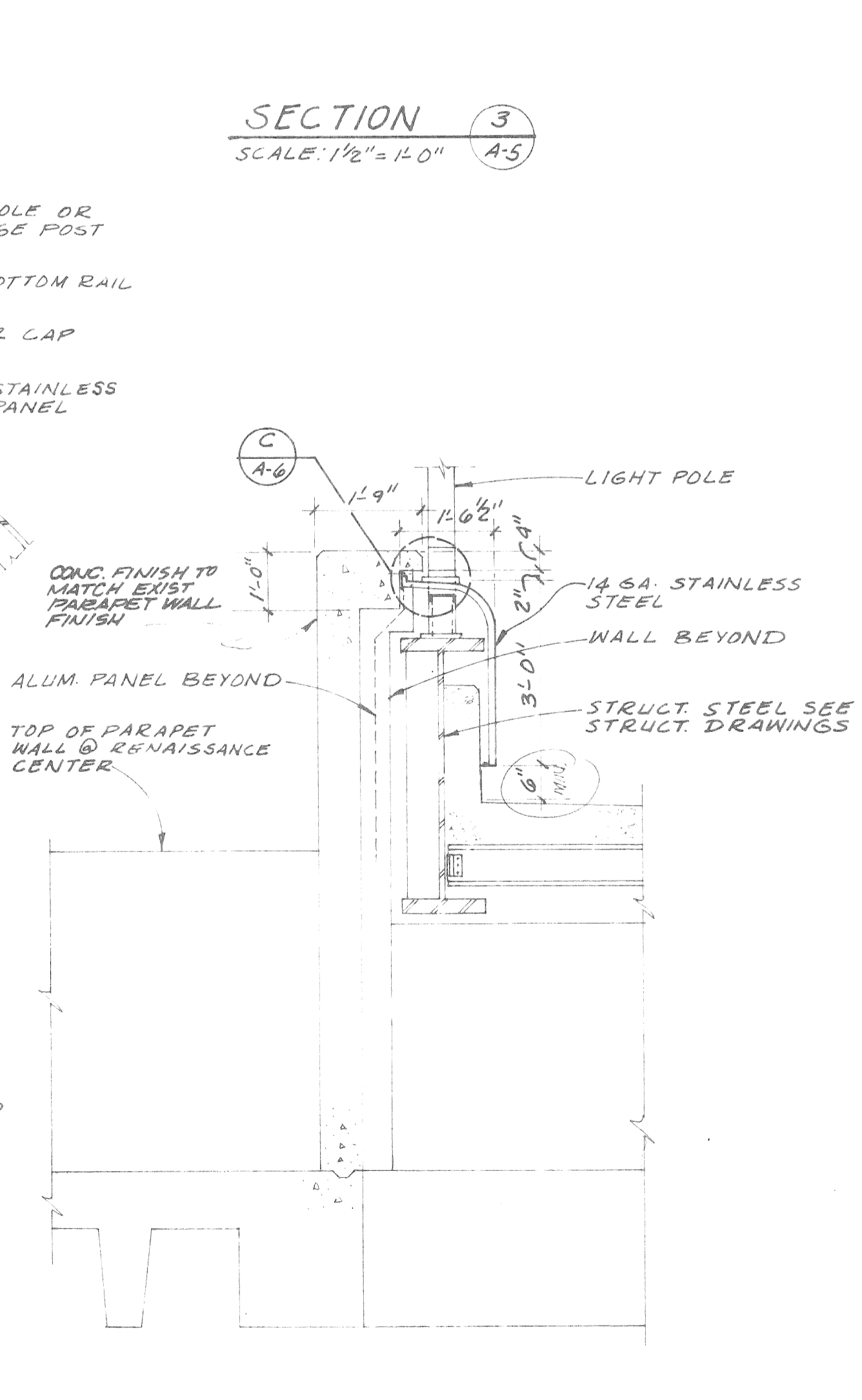

SECTION 5
SCALE: 1/2" = 1'-0" A-1

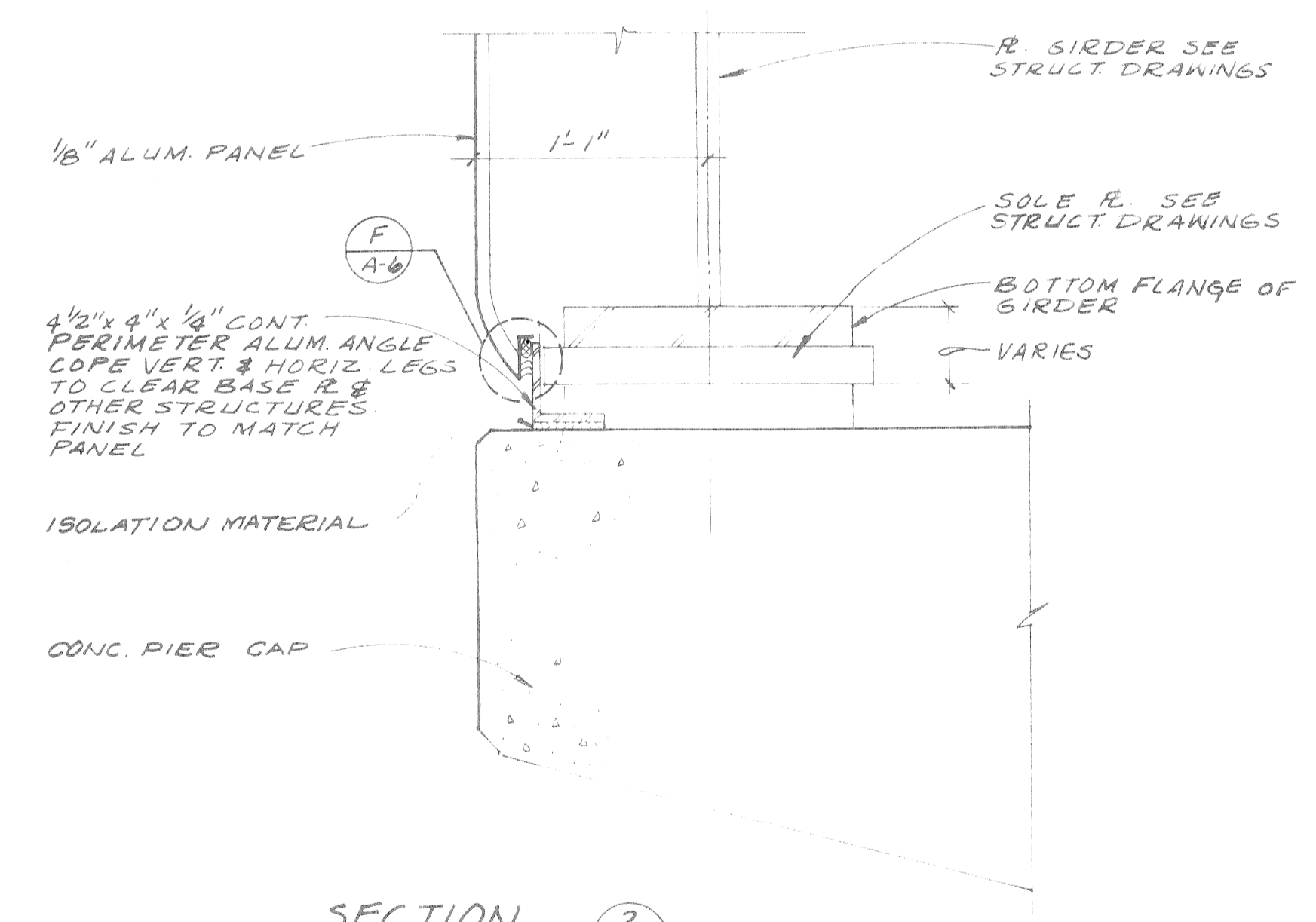

DETAIL F
SCALE: 1" = 1" A-6

SECTION 2
SCALE: 1/2" = 1'-0" A-5

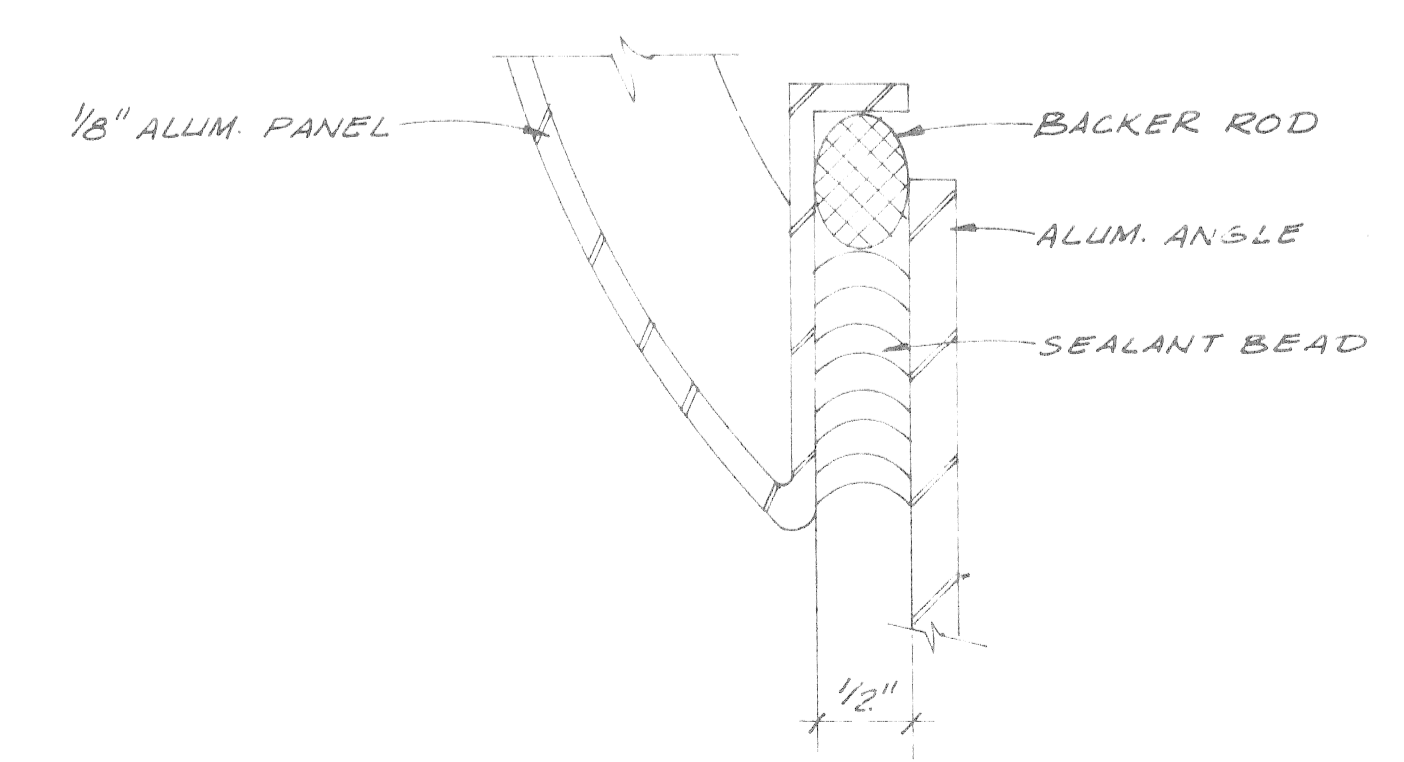

DATE	REVISIONS
CITY OF DETROIT	CITY ENGINEERING DEPARTMENT
CITY BRIDGE No. BP-27	
Project	Sheet Title
MADISON INTERNATIONAL OF MICHIGAN	RANDOLPH STREET PEDESTRIAN BRIDGE PANEL DETAILS
Engineers, Architects, Planners 1420 Washington Blvd. Detroit, Michigan 48226	
DESIGN BY P.O.A./D.L.M.	
DRAWN BY P.O.A.	
CHECKED BY P.A.	
DATE NOVEMBER, 89	
PROJECT NO. 8612	
SHEET NO. A-6	

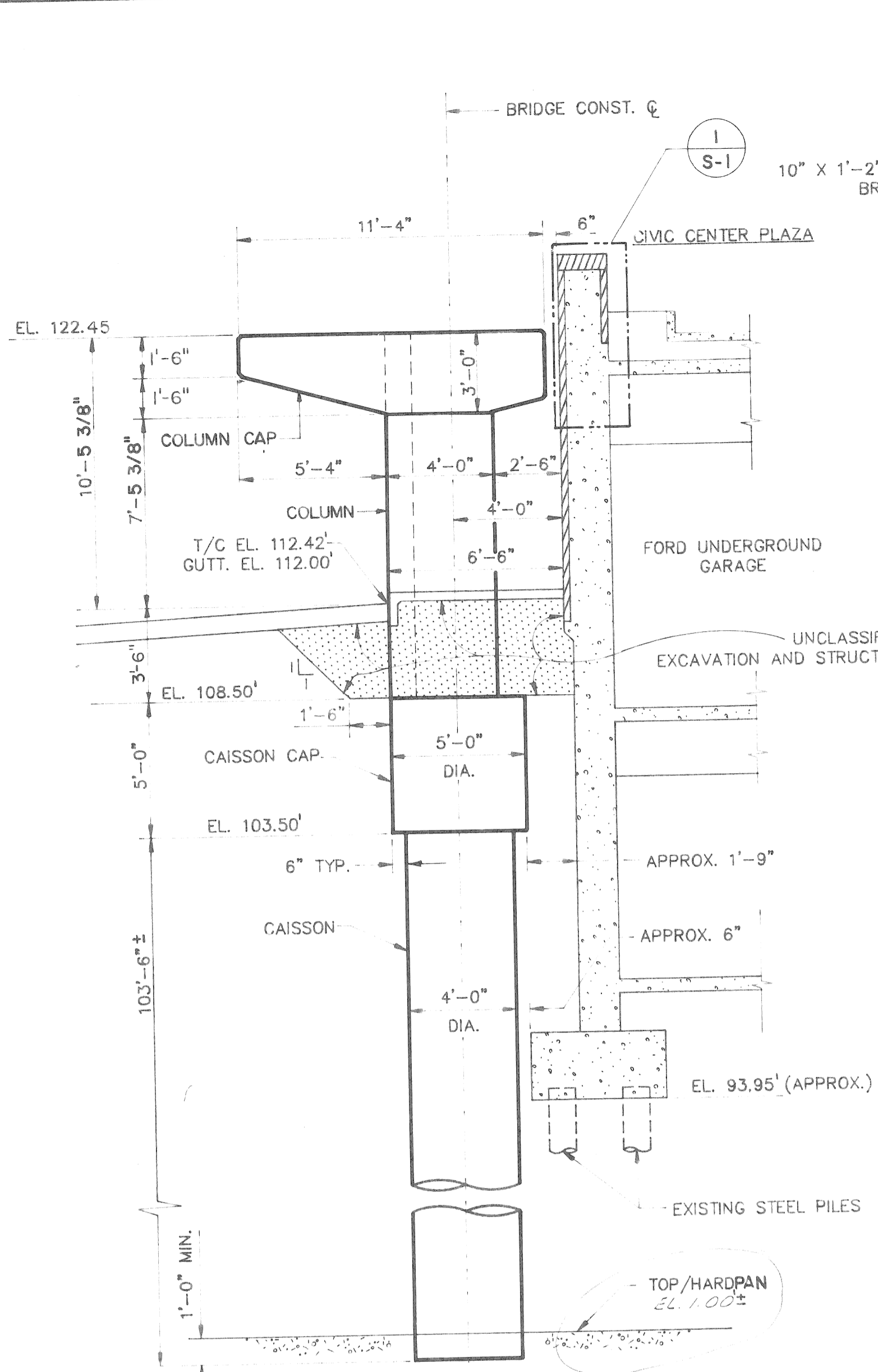

ELEVATION
SCALE: 1/4" = 1'-0"

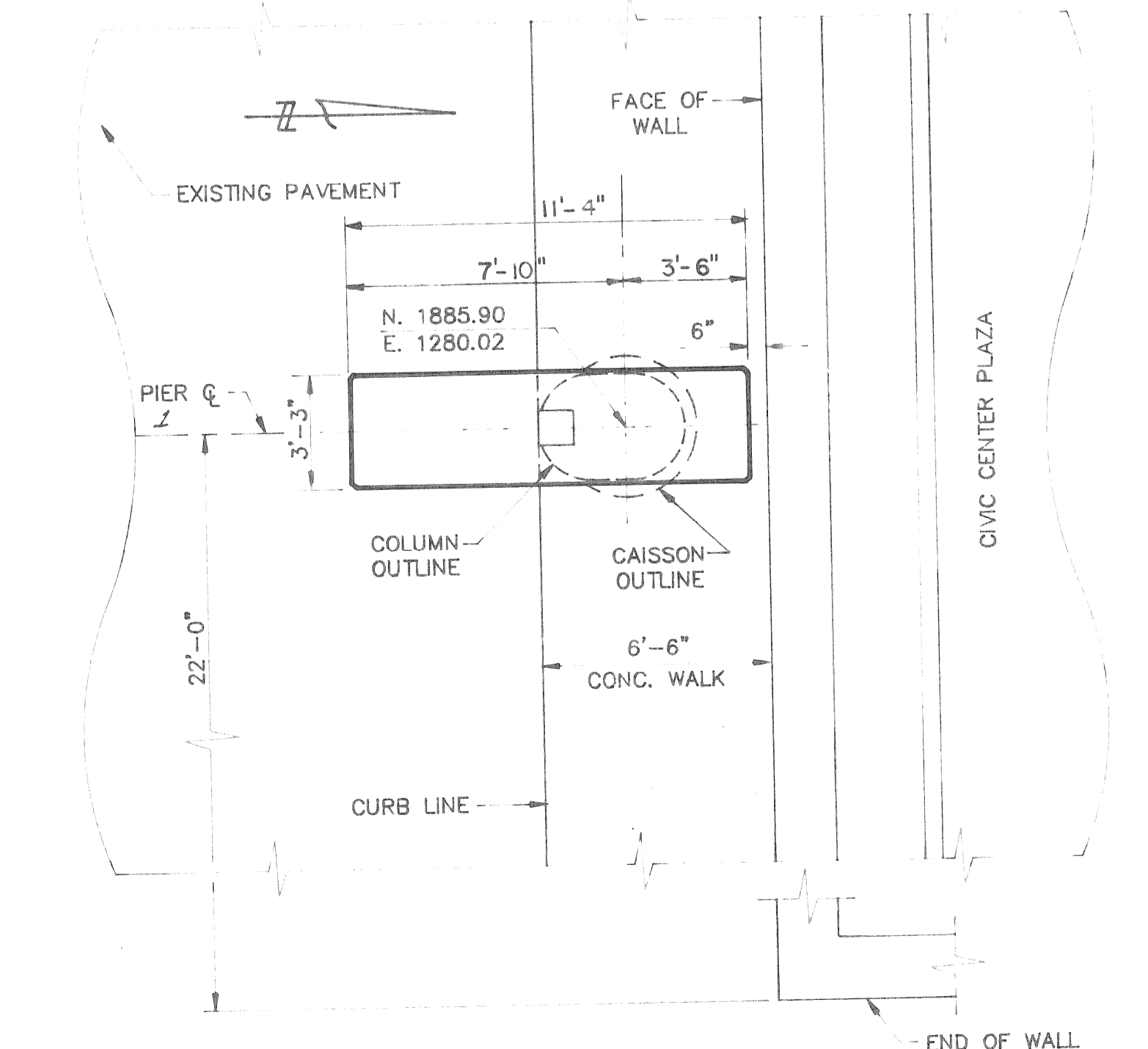

PLAN
SCALE: 1/4" = 1'-0"

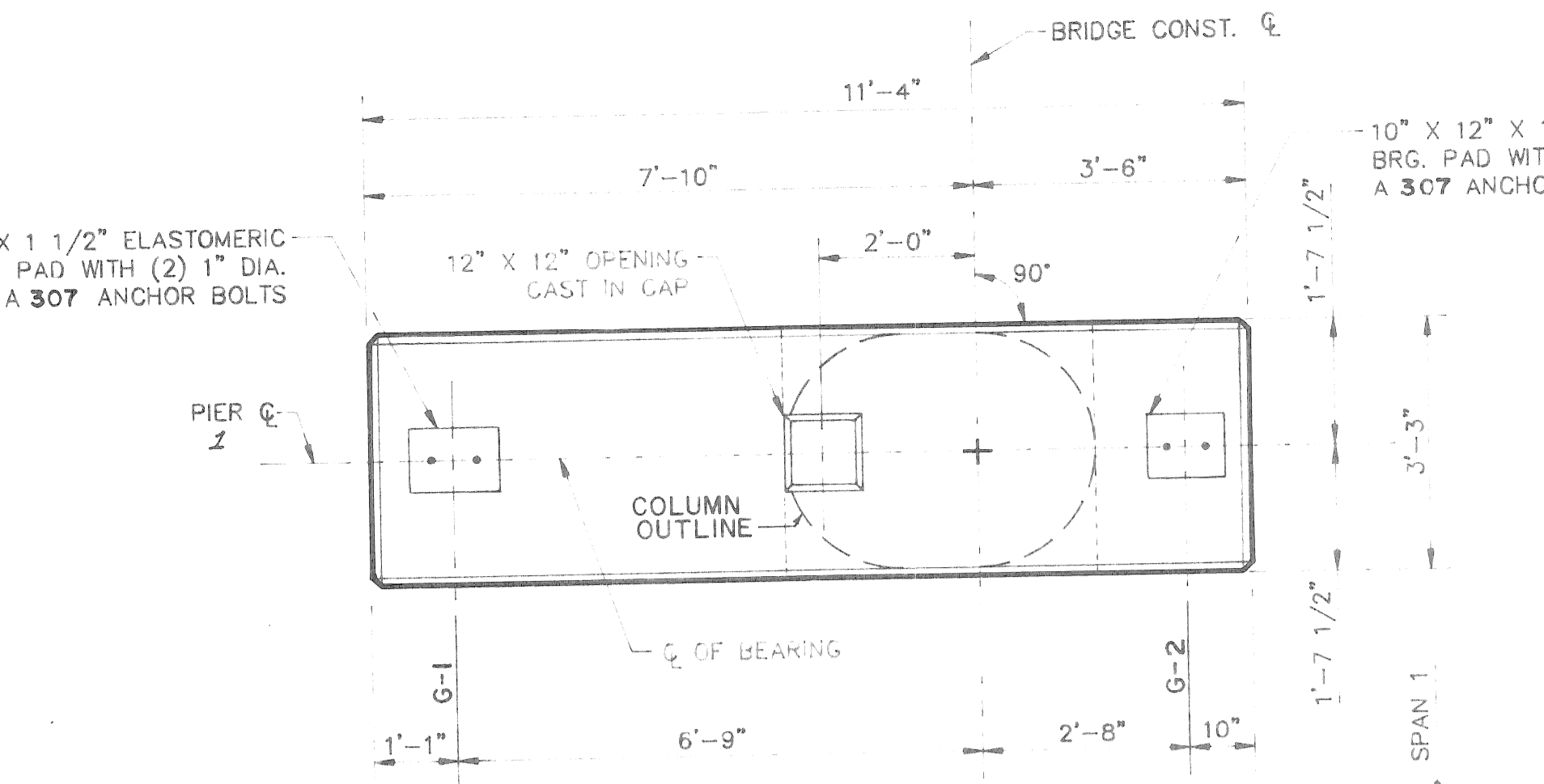

PLAN OF CAP
SCALE: 1/2" = 1'-0"

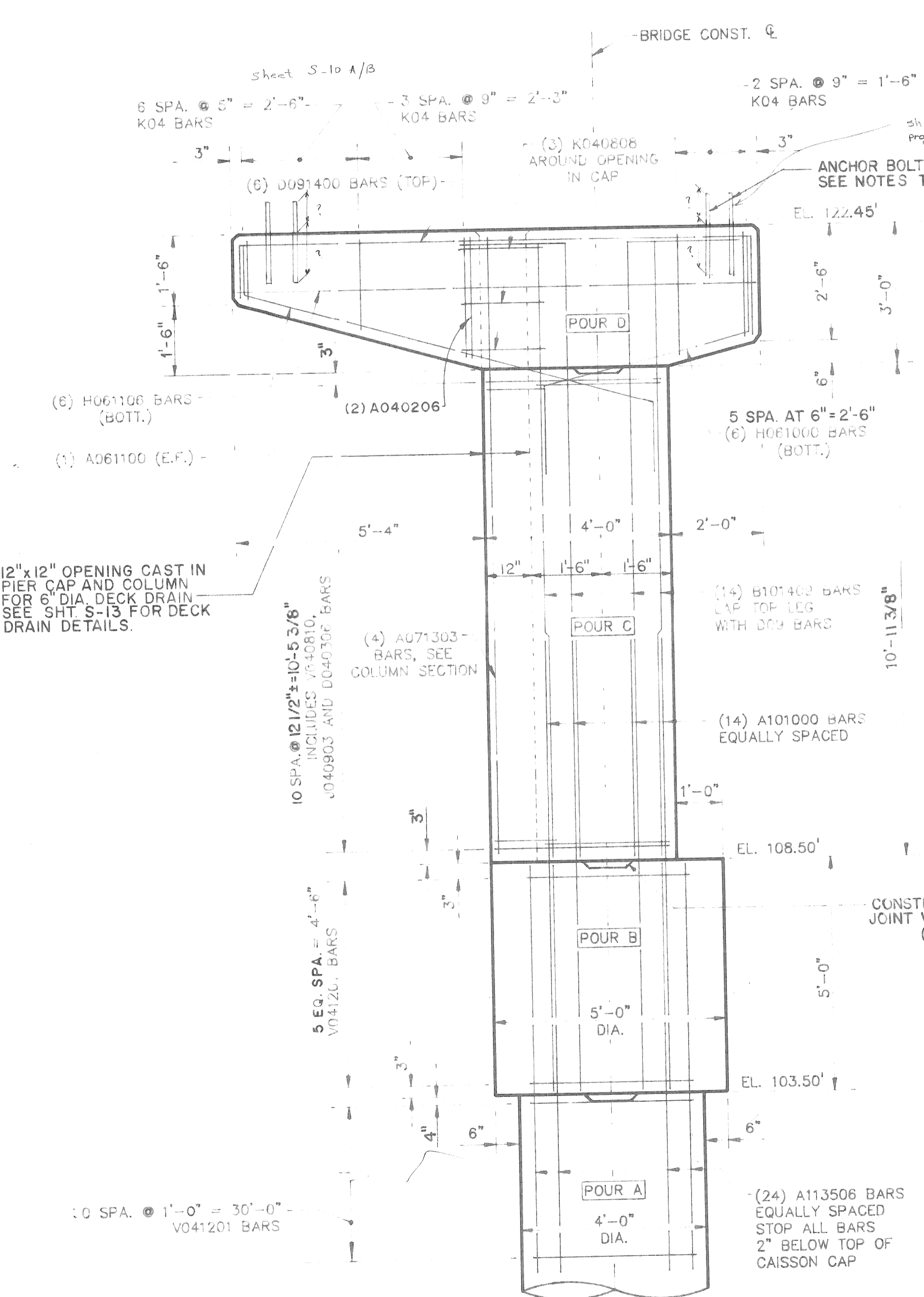

ELEVATION
SCALE: 1/2" = 1'-0"

SUBSTRUCTURE CONCRETE QUANTITIES

PIER 1		
POUR	LOCATION	AMOUNT (CU. YD.)
A	CAISSON	48.2
B	CAISSON CAP	3.8
C	COLUMN	3.6
D	COLUMN CAP	3.4
TOTAL CONCRETE:		59.0 CU. YD.

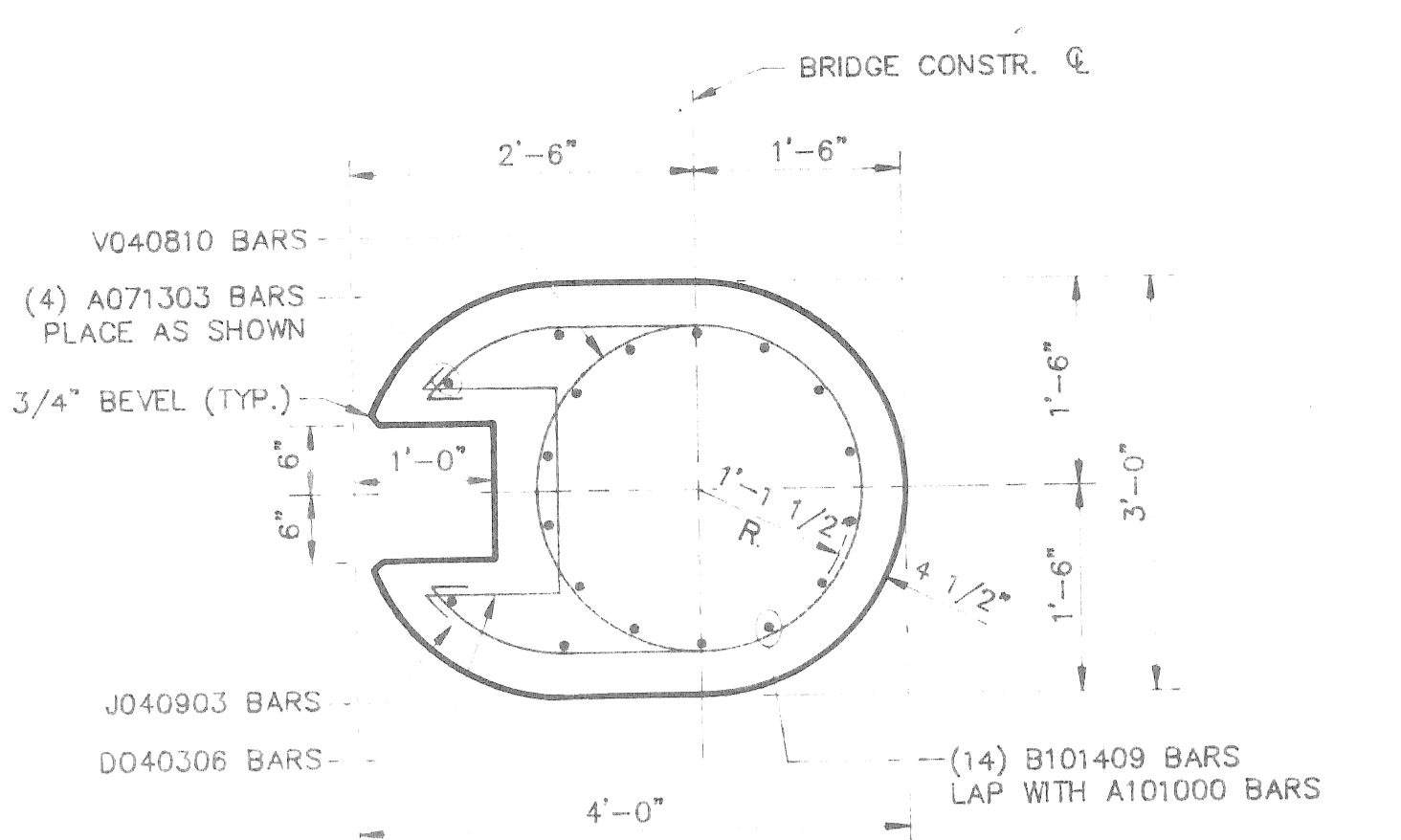

COLUMN SECTION
SCALE: 3/4" = 1'-0"

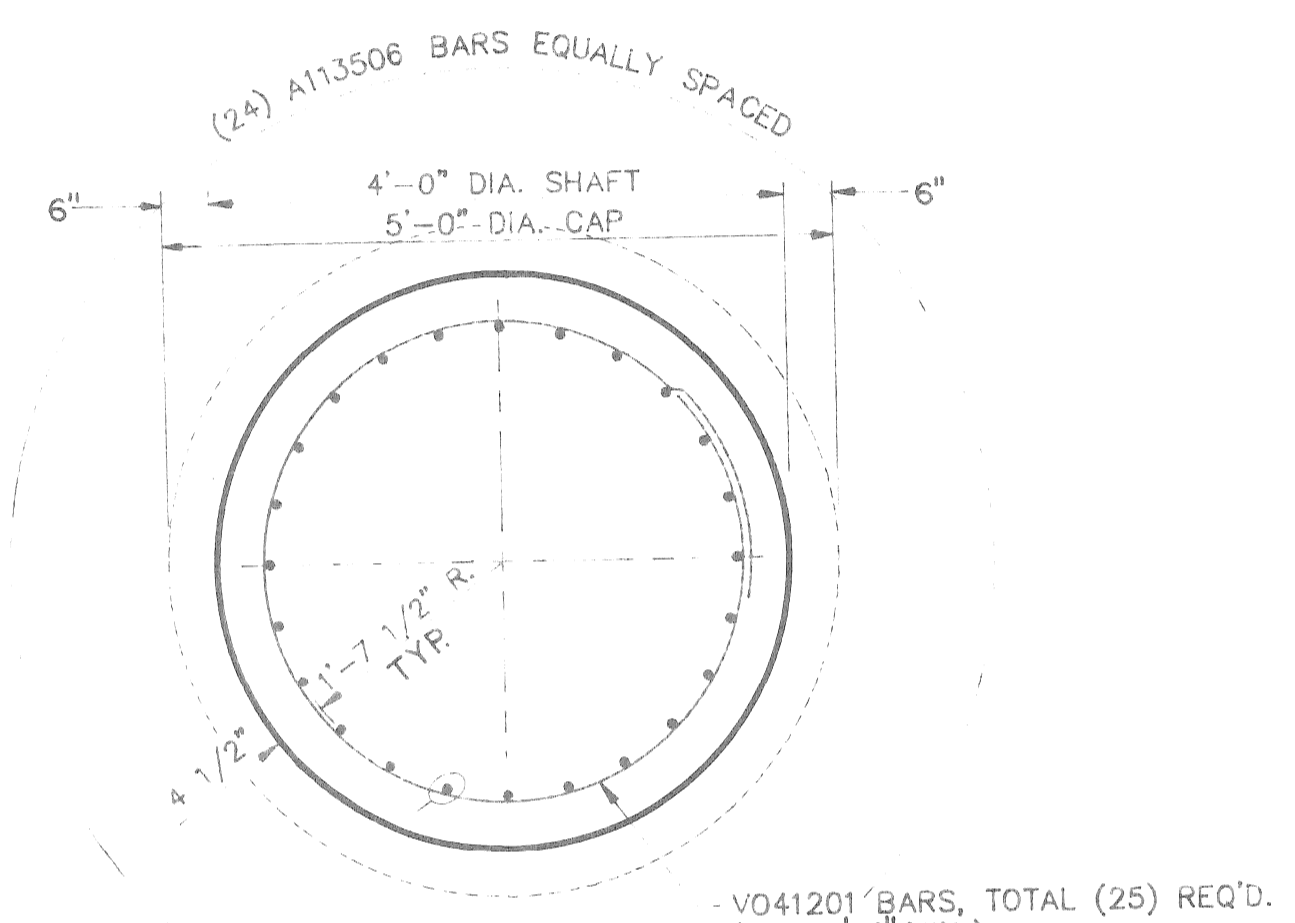

CAISSON SECTION
SCALE: 3/4" = 1'-0"

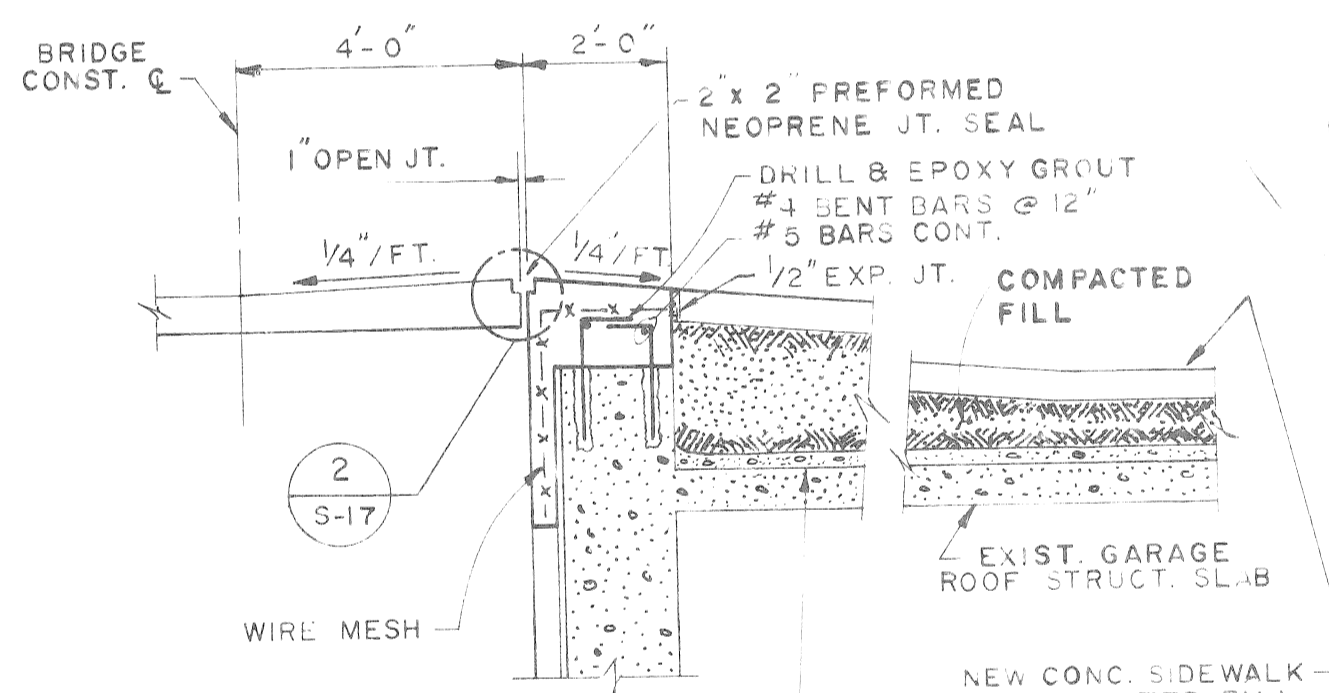

DETAIL 1
SCALE: 3/8" = 1'-0"

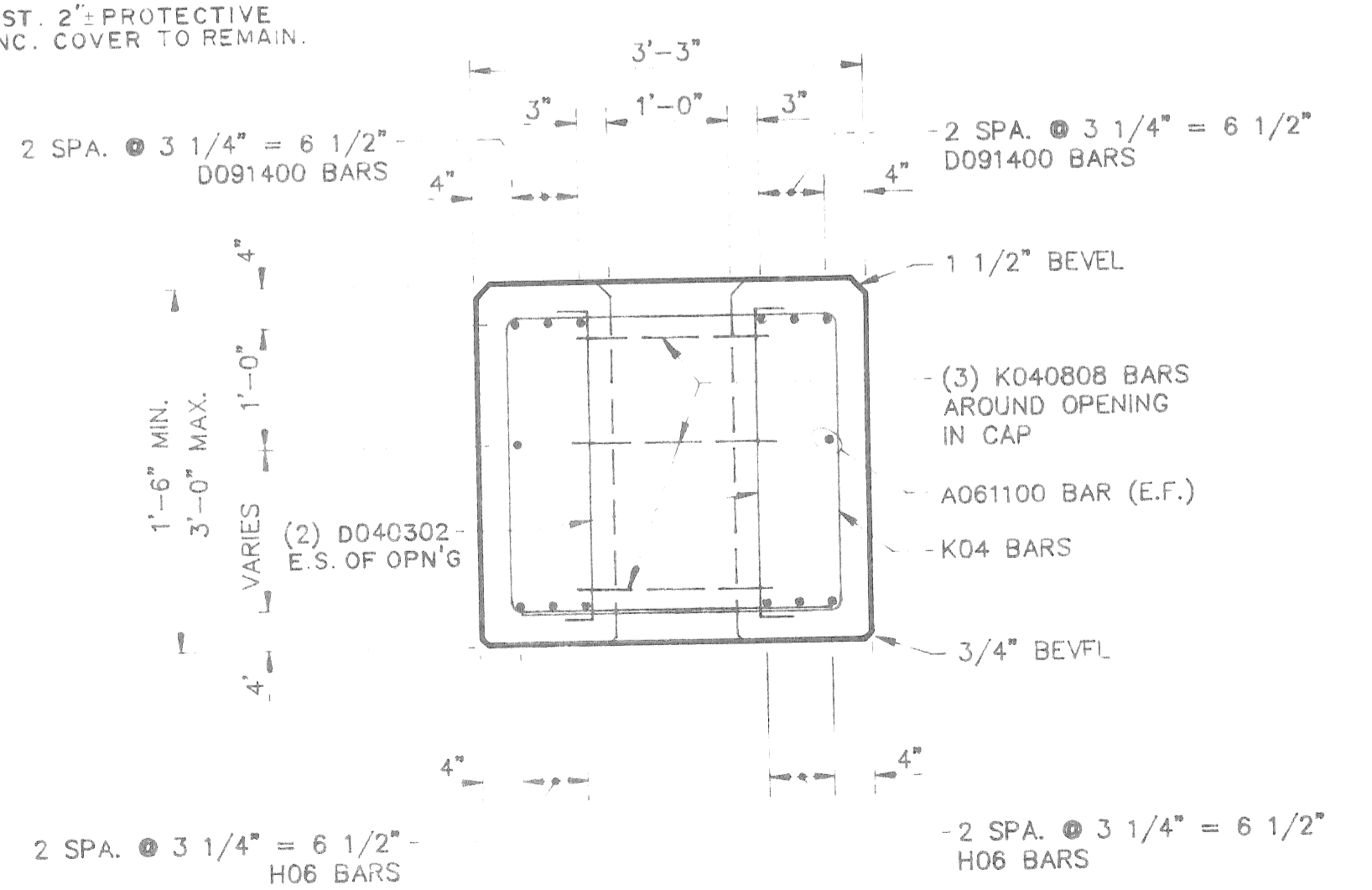

COLUMN CAP SECTION
SCALE: 3/4" = 1'-0"

- NOTES:**
1. FOR ANCHOR BOLT DETAILS, SEE SHEET S-10
 2. FOR REINF. STEEL BEND TYPES SEE SHEET S-19
 3. G-1, G-2, ... G-6 DENOTES GIRDER NUMBERS/MARKS. SEE SHEET S-6 FOR MORE DETAILS.

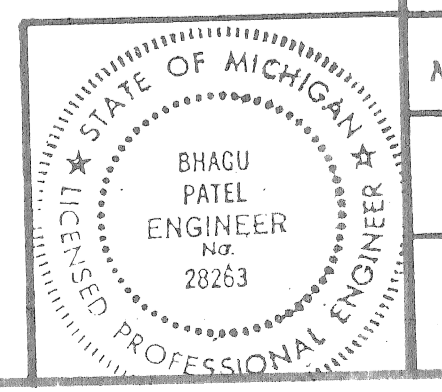

REVISION

DATE

CITY OF DETROIT

CITY ENGINEERING DEPARTMENT

CITY BRIDGE No. BP-27

PROJECT: RANDOLPH STREET PEDESTRIAN BRIDGE

SHEET TITLE: PIER 1 DETAILS

MADISON MADISON INTERNATIONAL OF MICHIGAN

Engineers, Architects, Planners
1420 Washington Blvd.
Detroit, Michigan 48226

DESIGN BY: K.C.H./S.O.

DRAWN BY: B.M.M.

CHECKED BY: P.A.

DATE: NOVEMBER, 89

PROJECT NO.: 8612

SHEET NO.: S-1

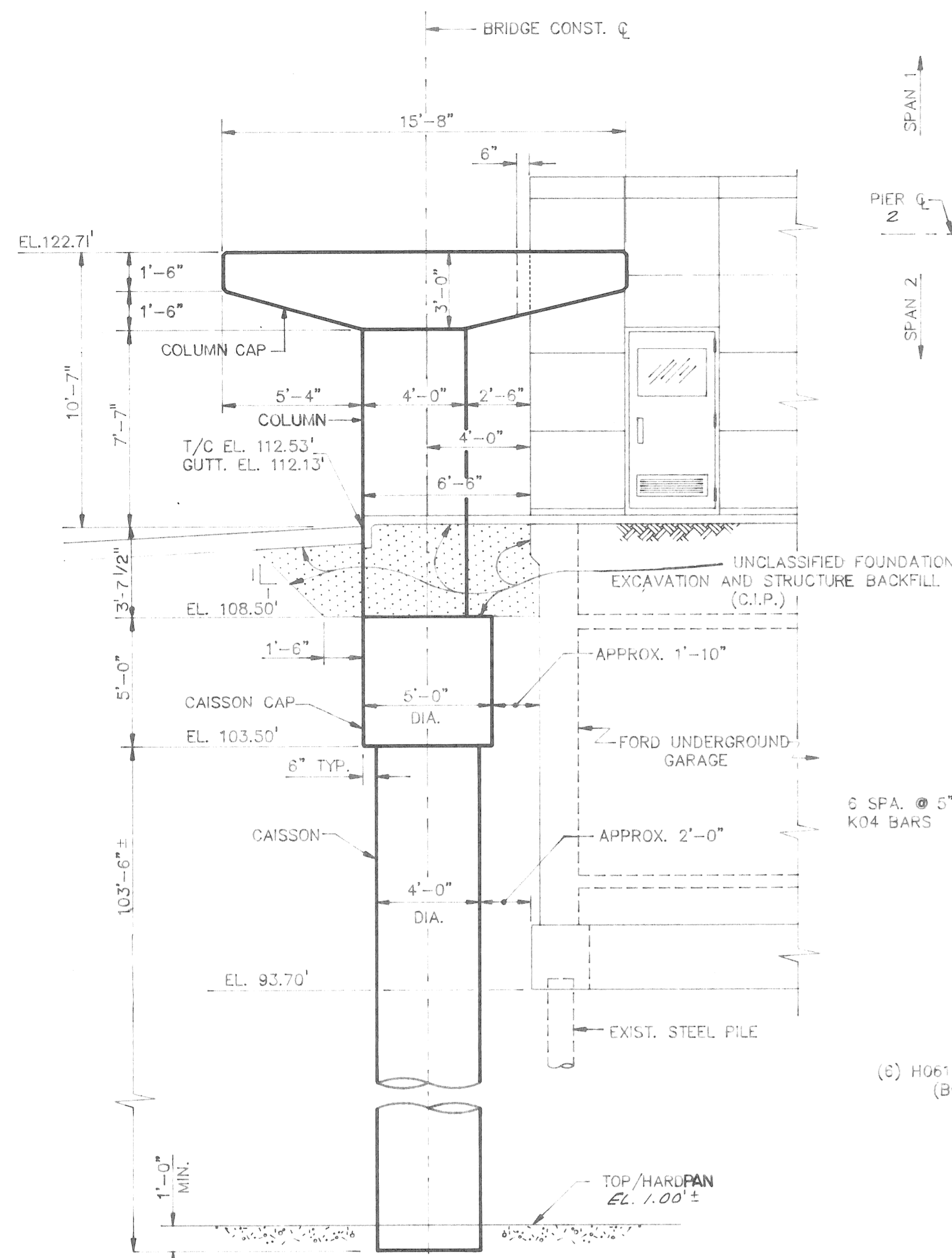

ELEVATION
SCALE: 1/4" = 1'-0"

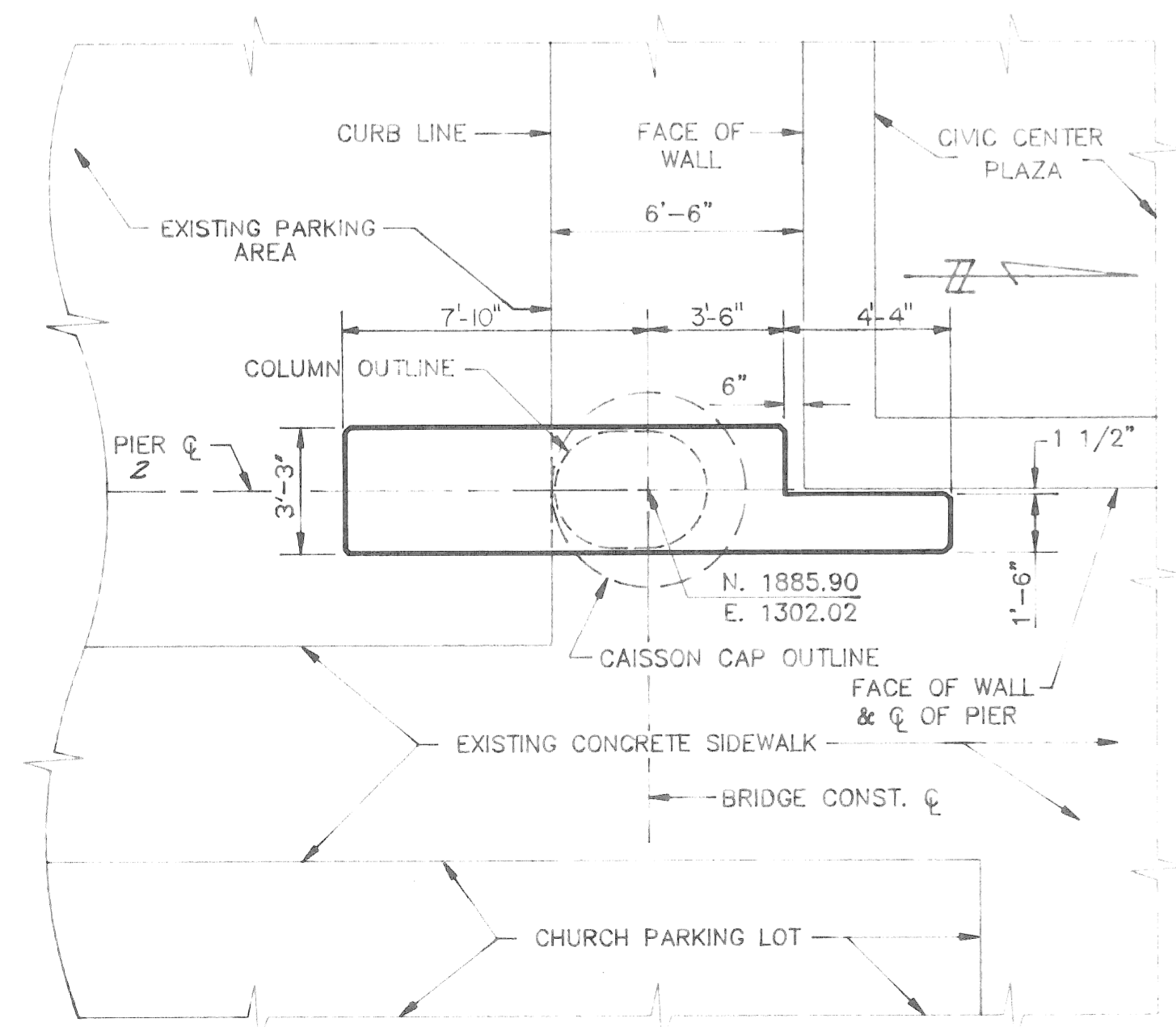

PLAN
SCALE: 1/4" = 1'-0"

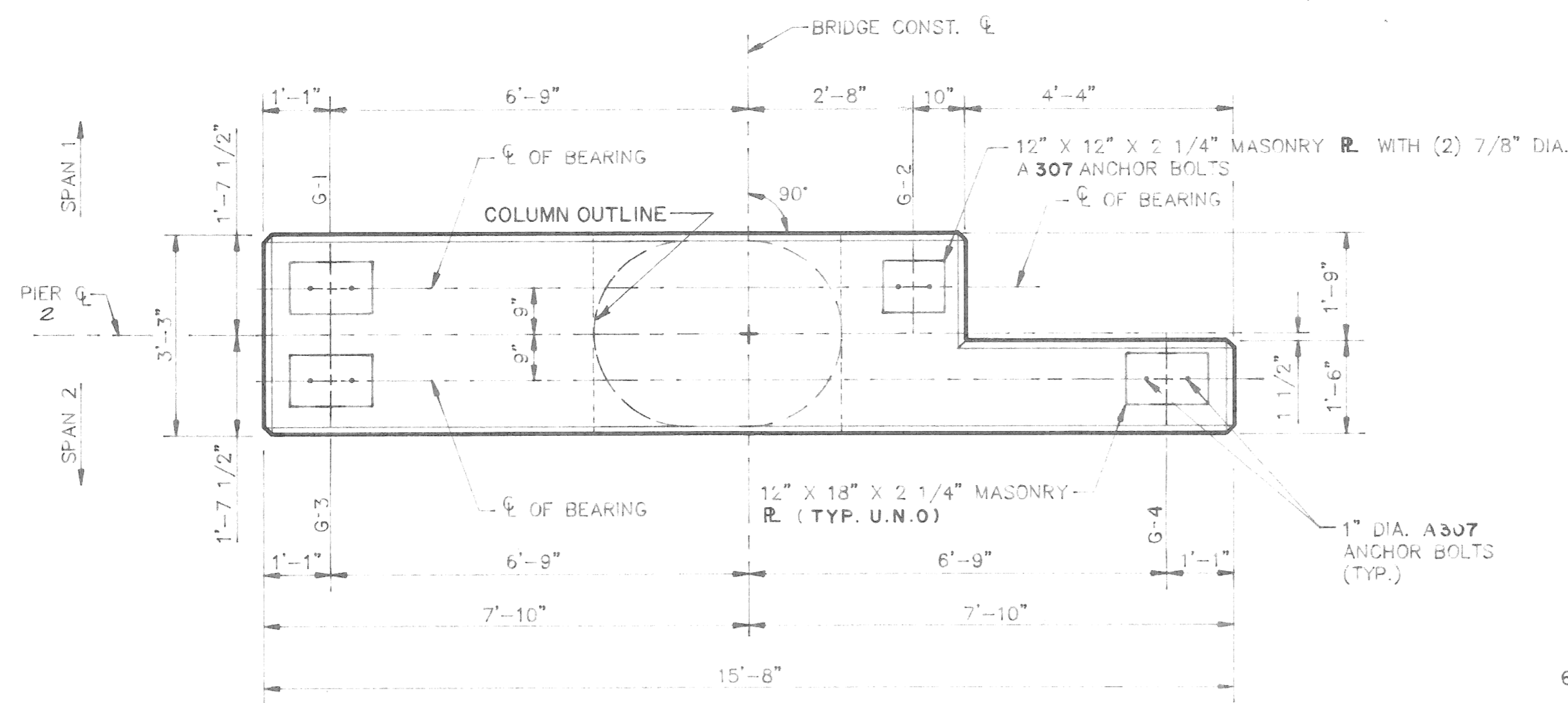

PLAN OF CAP
SCALE: 1/2" = 1'-0"

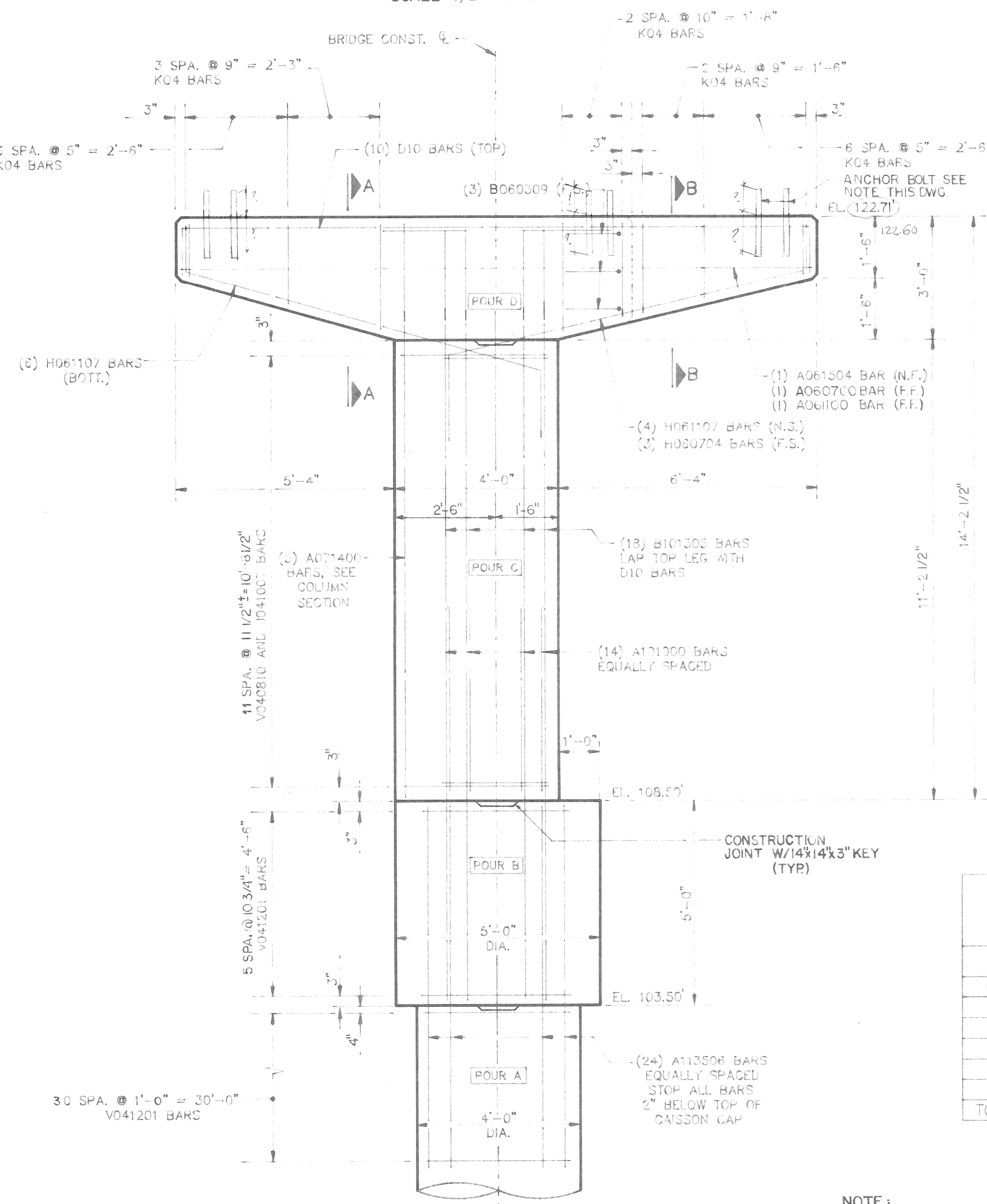

ELEVATION
SCALE: 1/2" = 1'-0"

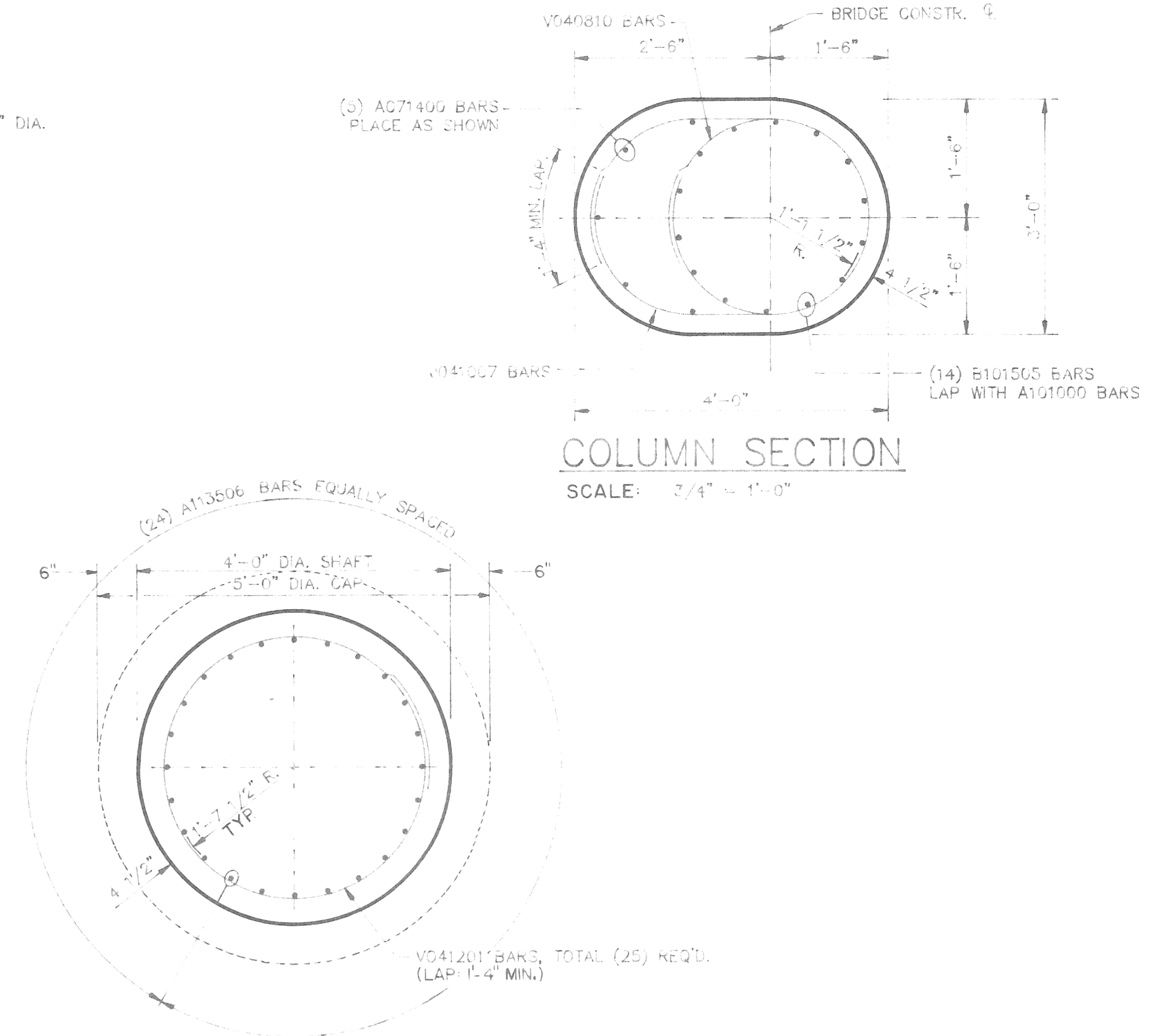

CAISSON SECTION
SCALE: 3/4" = 1'-0"

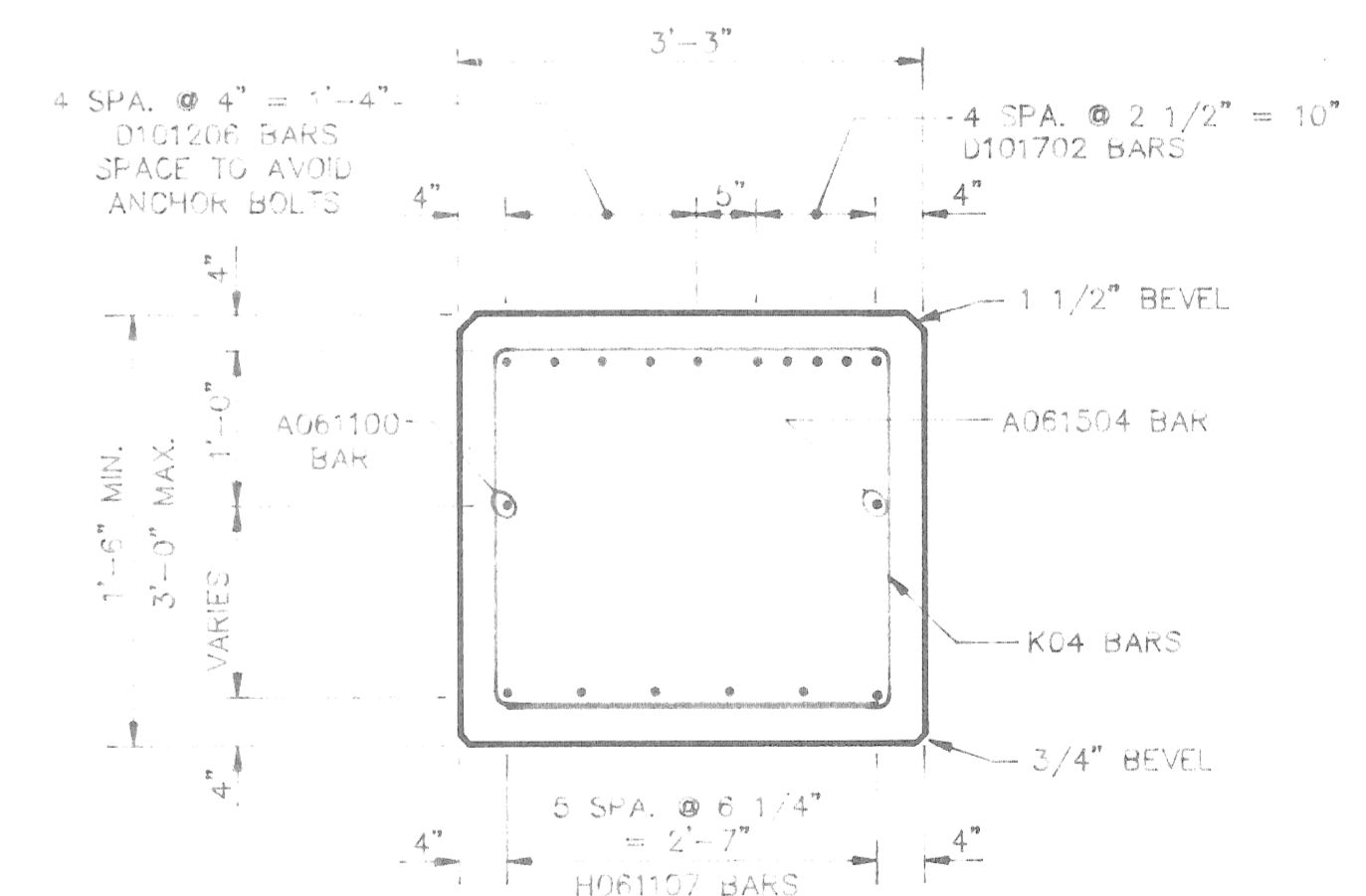

SECTION A-A
SCALE: 3/4" = 1'-0"

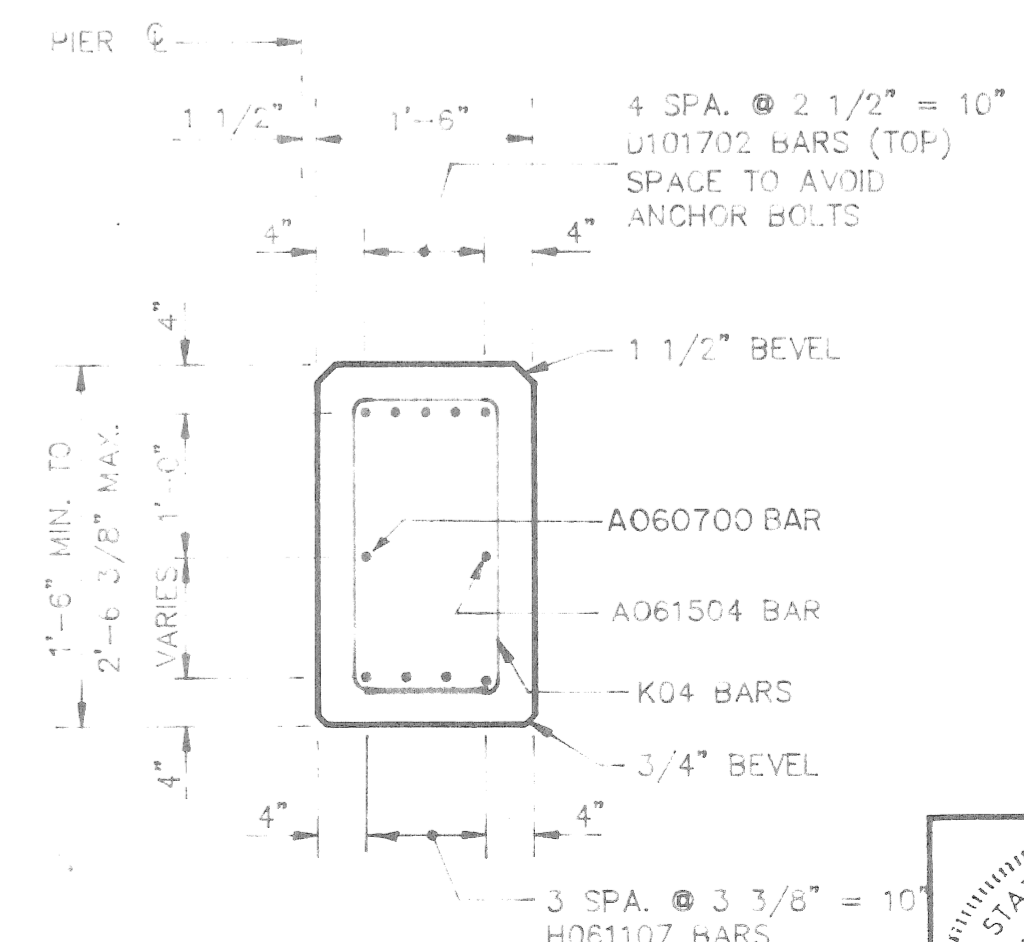

SECTION B-B
SCALE: 3/4" = 1'-0"

SUBSTRUCTURE CONCRETE QUANTITIES		
PIER 2		
POUR	LOCATION	AMOUNT (CU. YD.)
A	CAISSON	48.2
B	CAISSON CAP	3.9
C	COLUMN	3.8
D	COLUMN CAP	4.0
TOTAL CONCRETE:		59.9 CU. YD.

NOTE:
I. FOR ANCHOR BOLT DETAILS, SEE SHEET S-10

REVISION	
DATE	
BY	
FOR	

CITY OF DETROIT
CITY ENGINEERING DEPARTMENT
CITY BRIDGE No. BP-22

RANDOLPH STREET PEDESTRIAN BRIDGE
PIER 2 DETAILS

MADISON MADISON
INTERNATIONAL OF MICHIGAN
Engineers, Architects, Planners
1420 Washington Blvd.
Detroit, Michigan 48226

DESIGN BY
K.C.H./S.O.
DRAWN BY
B.M.M.
CHECKED BY
P.A.

DATE
NOVEMBER, 89
PROJECT NO.
8612
SHEET NO.
S-2

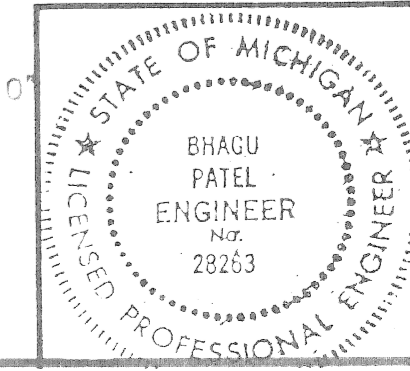

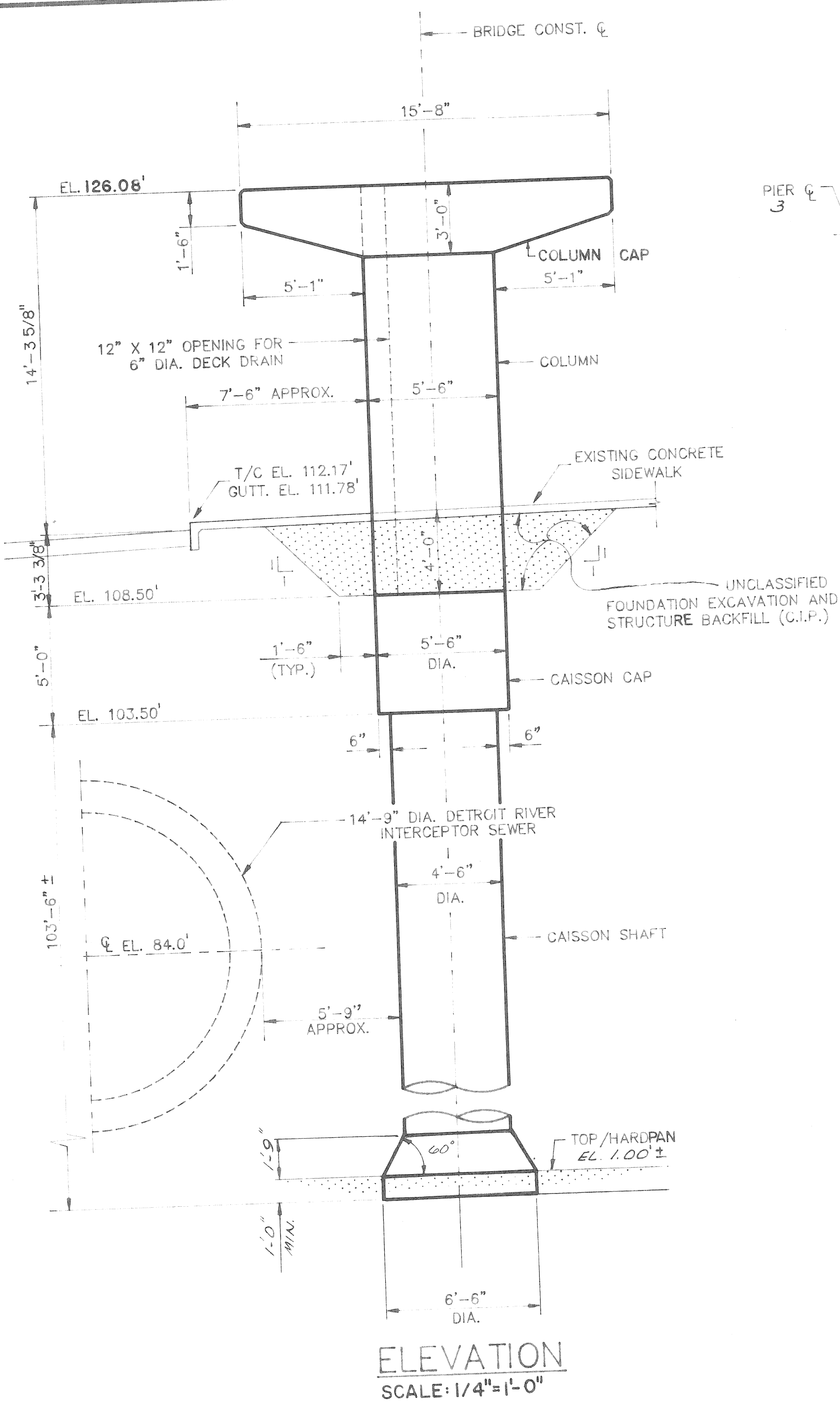

ELEVATION
SCALE: 1/4" = 1'-0"

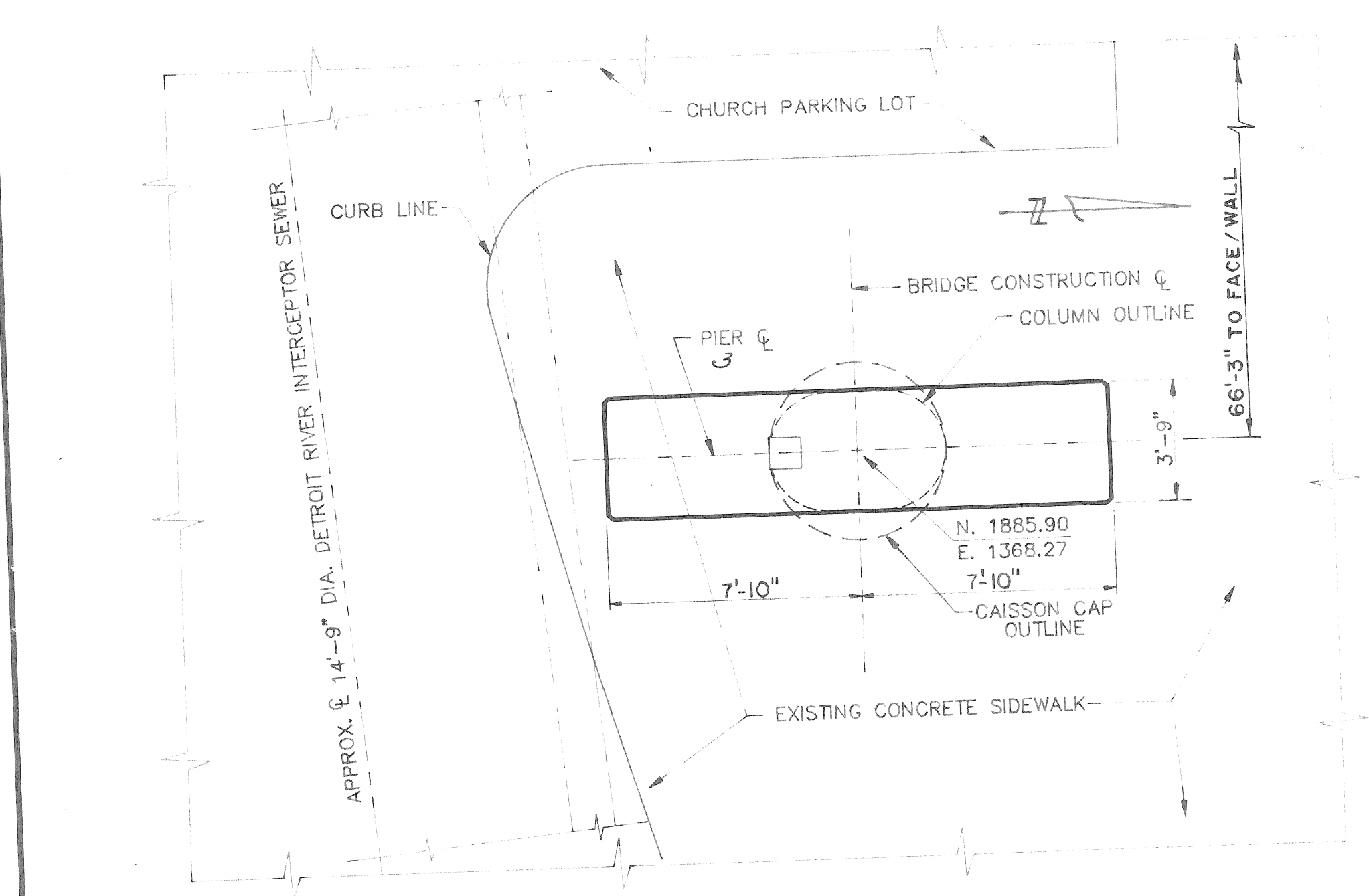

PLAN
SCALE: 1/4" = 1'-0"

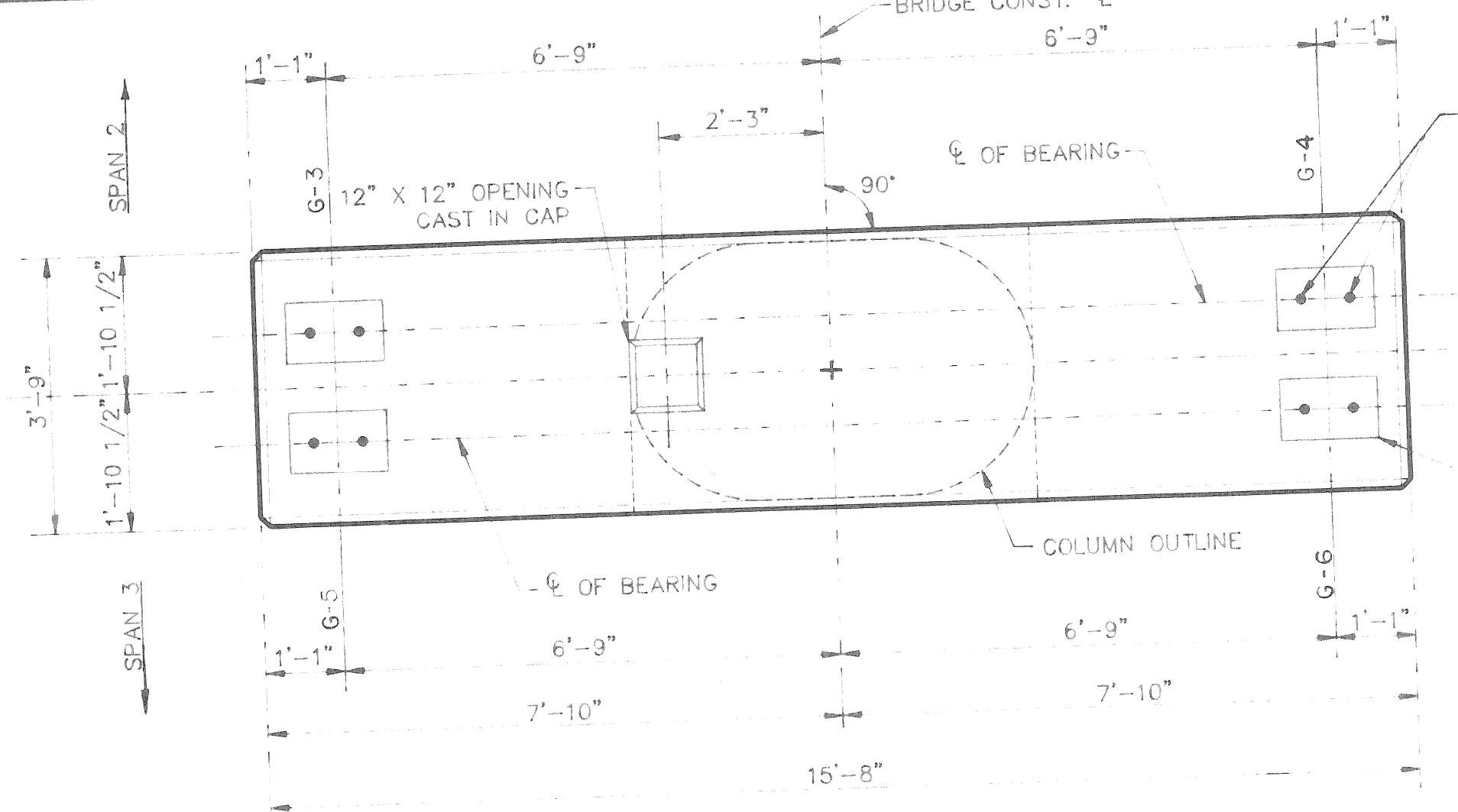

PLAN OF CAP
SCALE: 1/2" = 1'-0"

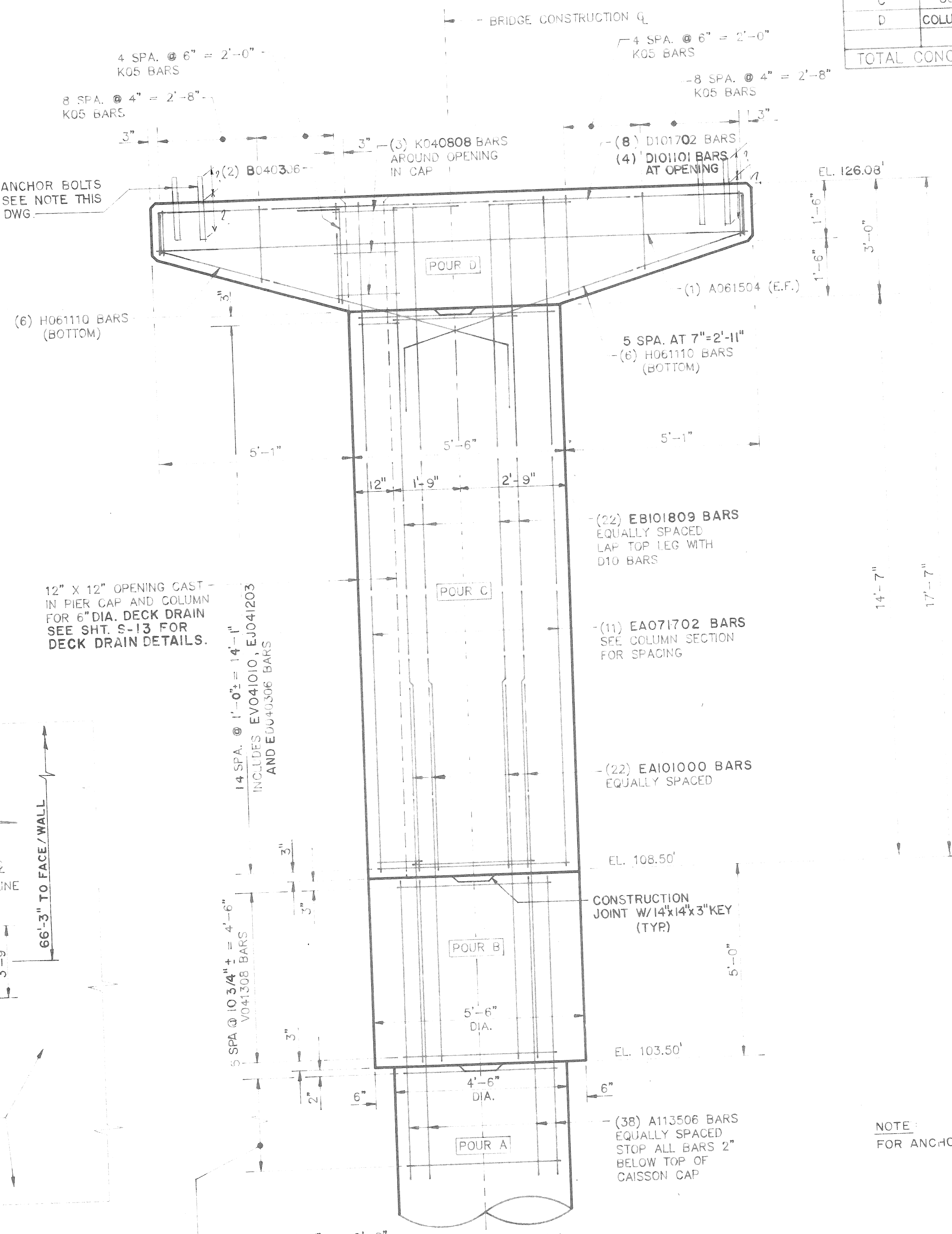

ELEVATION
SCALE: 1/2" = 1'-0"

SUBSTRUCTURE CONCRETE QUANTITIES

PIER 3

POUR	LOCATION	AMOUNT (CU. YD.)
A	CAISSON	64.0
B	CAISSON CAP	4.40
C	COLUMN	8.50
D	COLUMN CAP	5.40
TOTAL CONCRETE:		82.30 CU. YD.

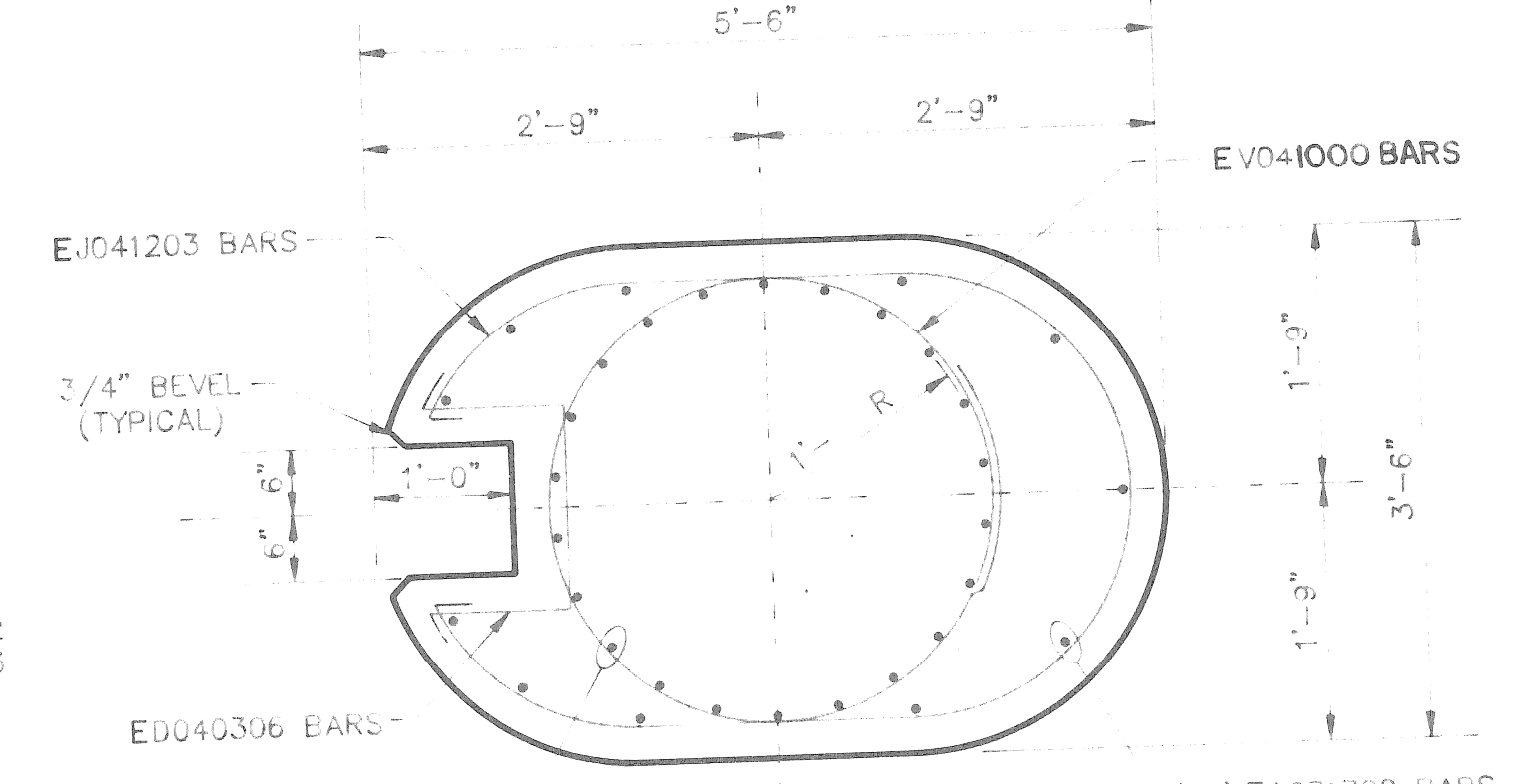

COLUMN SECTION
SCALE: 3/4" = 1'-0"

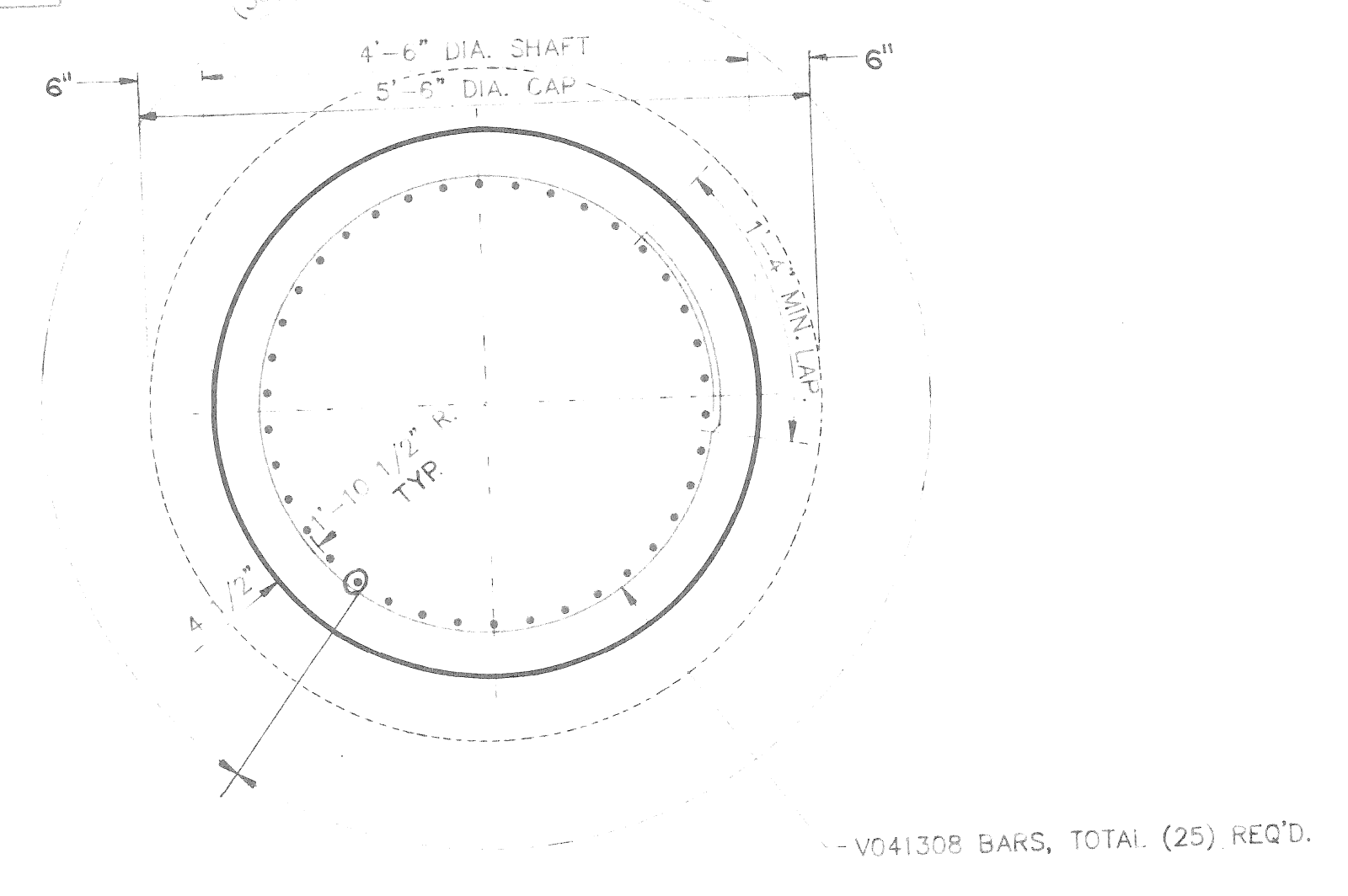

CAISSON SECTION
SCALE: 3/4" = 1'-0"

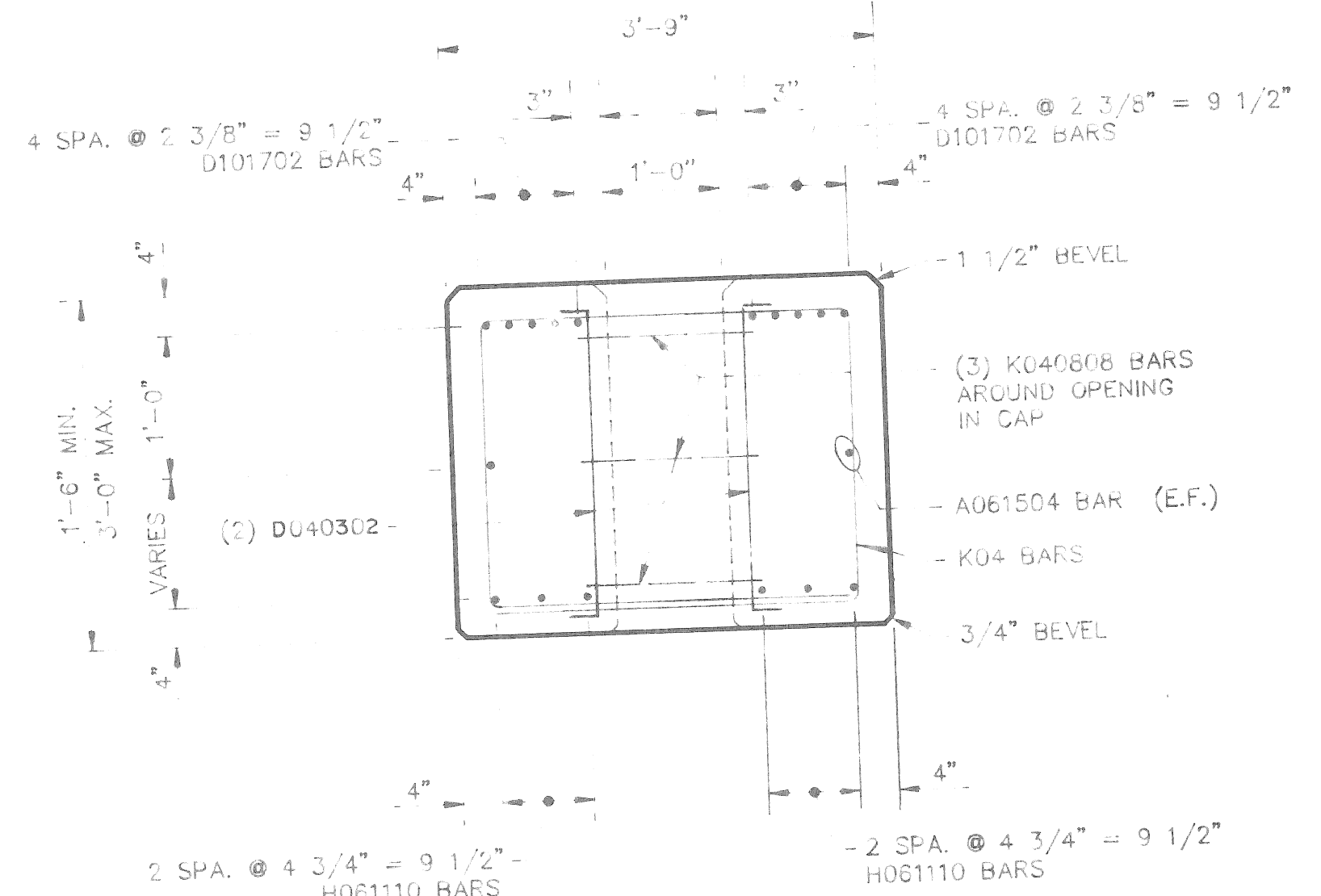

COLUMN CAP SECTION
SCALE: 3/4" = 1'-0"

NOTE:
FOR ANCHOR BOLT DETAILS, SEE SHEET S-10

REVISION
DATE: []
APPROVED BY: []
DESIGNED BY: []
DRAWN BY: []
CHECKED BY: []
DATE: NOVEMBER, 2012
PROJECT NO. 8612
SHEET NO. S-3

CITY OF DETROIT
CITY ENGINEERING DEPARTMENT
CITY BRIDGE No. BP-27

PROJECT: RANDOLPH STREET PEDESTRIAN BRIDGE
SHEET TITLE: PIER 3 DETAILS

MADISON MADISON INTERNATIONAL OF MICHIGAN
Engineers, Architects, Planners
1420 Washington Blvd.
Detroit, Michigan 48226

DESIGN BY: K.C.H./S.O.
DRAWN BY: B.M.M.
CHECKED BY: P.A.

STATE OF MICHIGAN
BHAGU PATEL
ENGINEER
No. 28253
LICENSED PROFESSIONAL ENGINEER

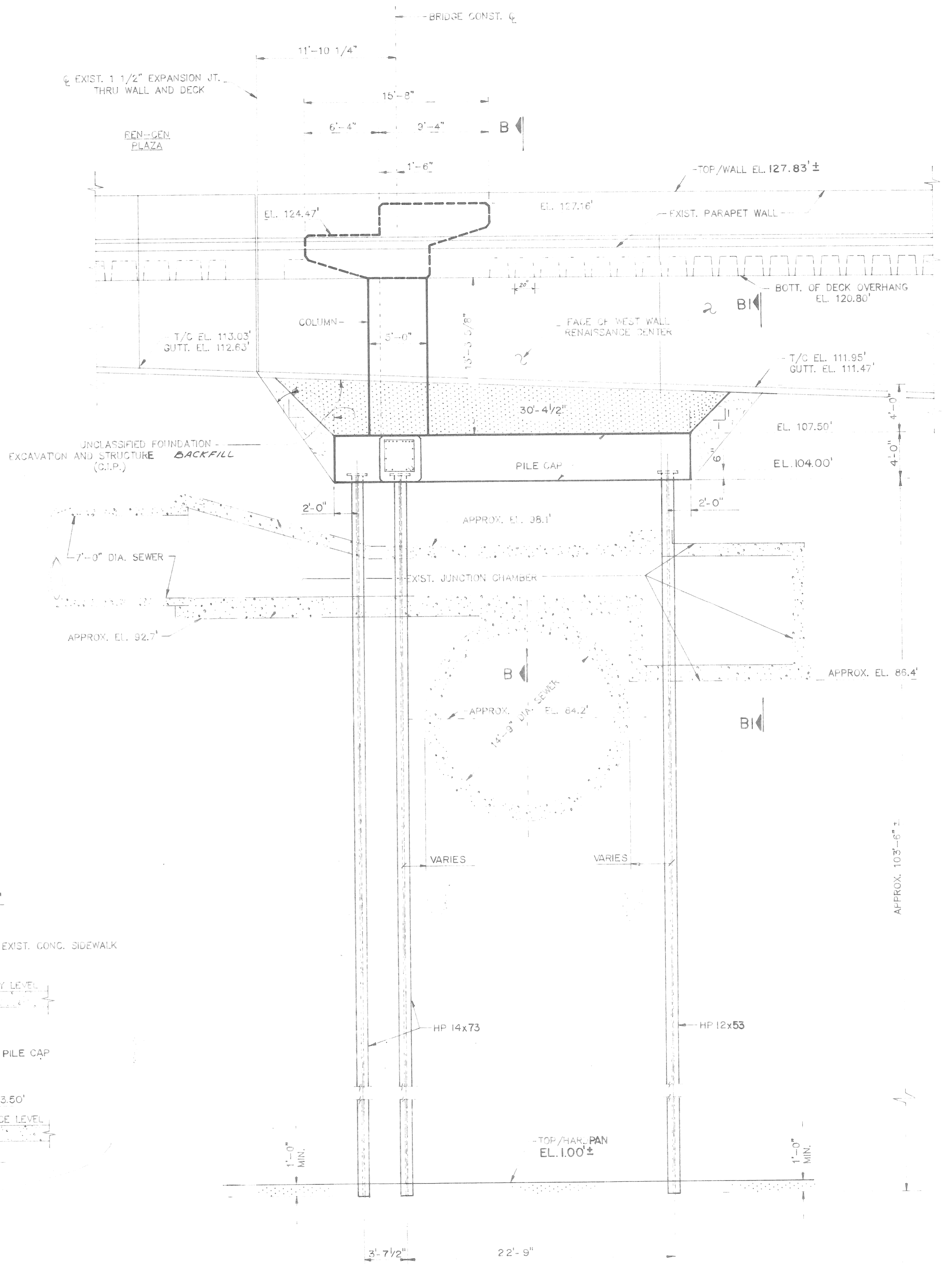
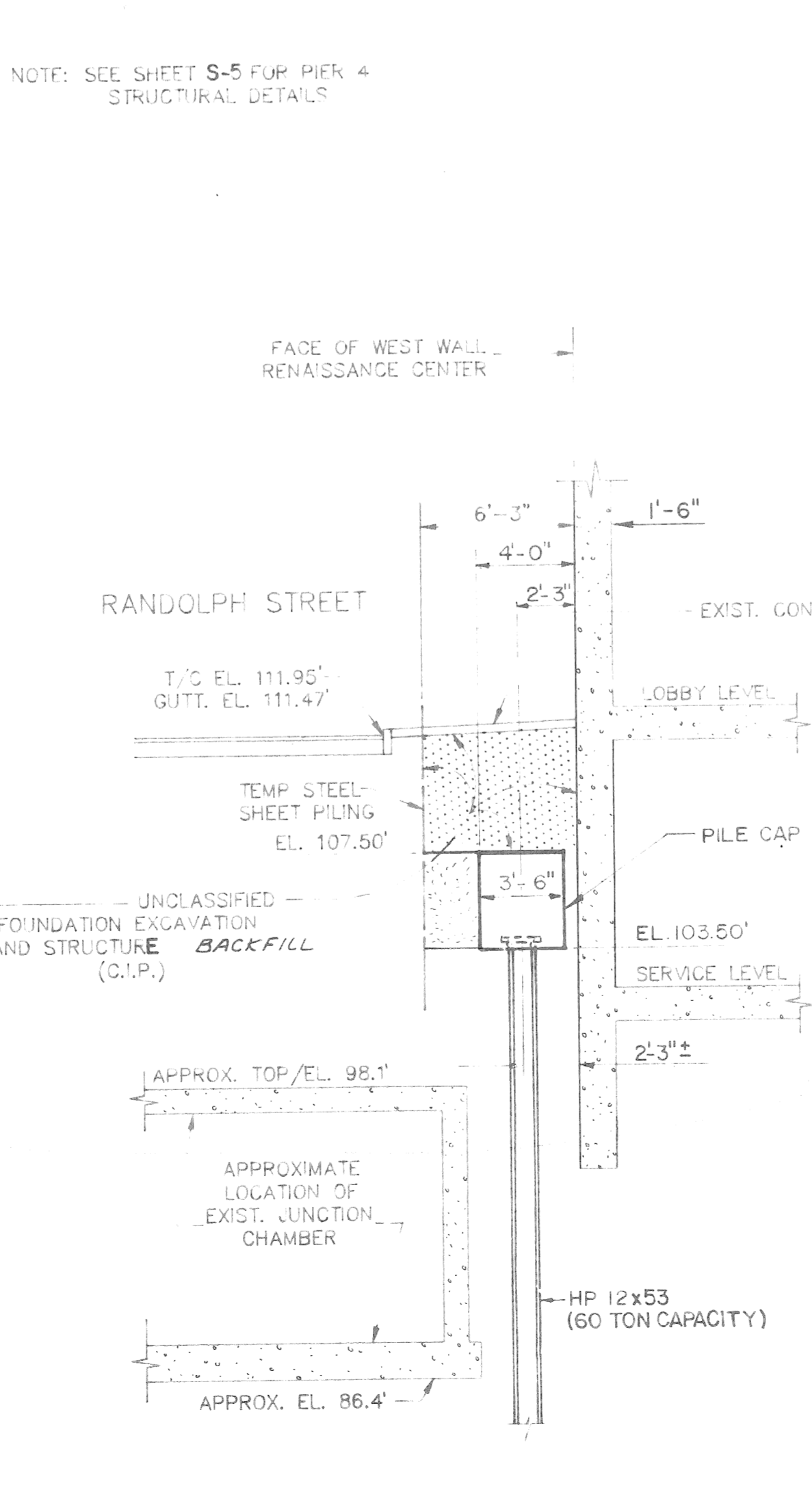
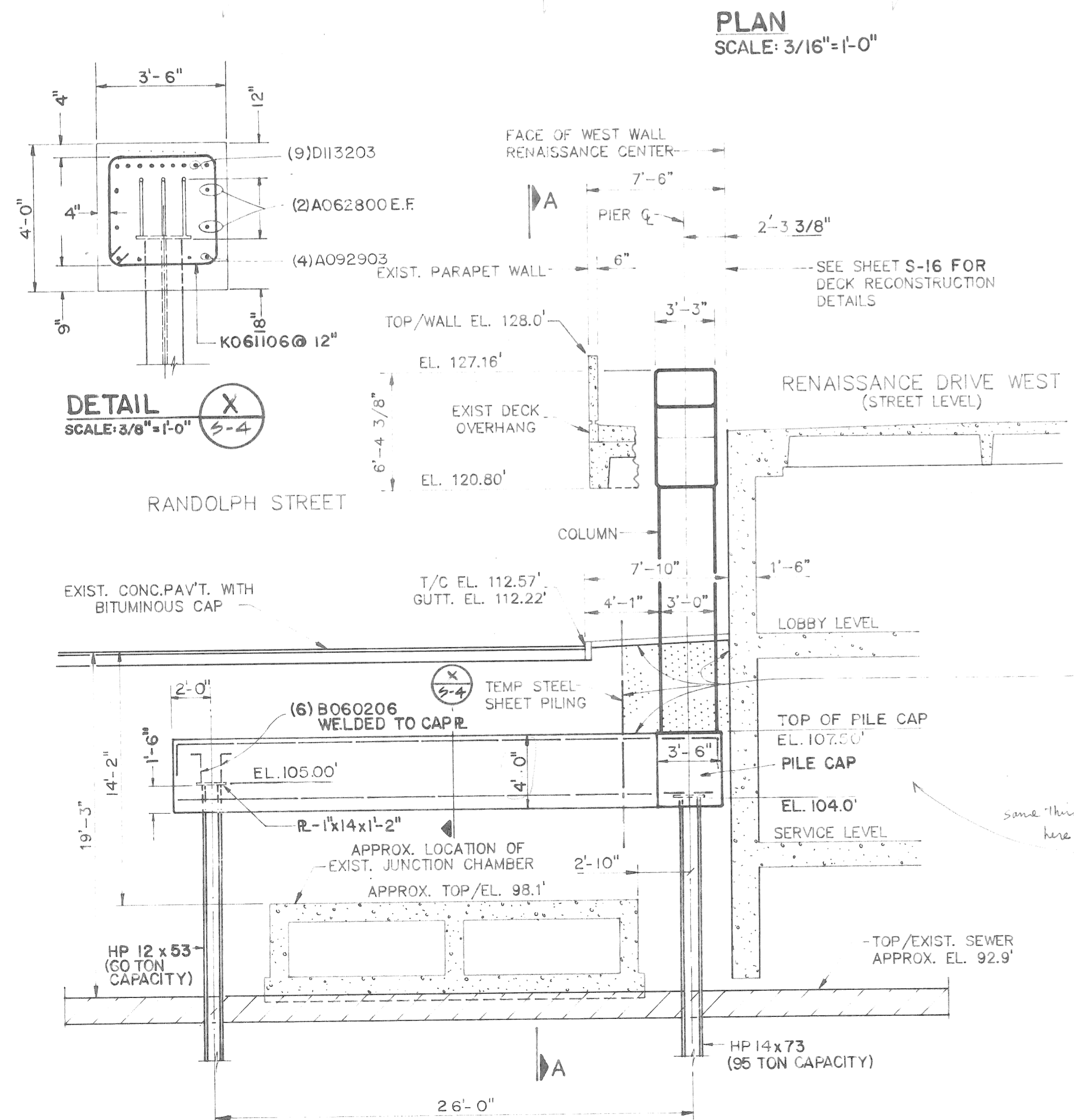
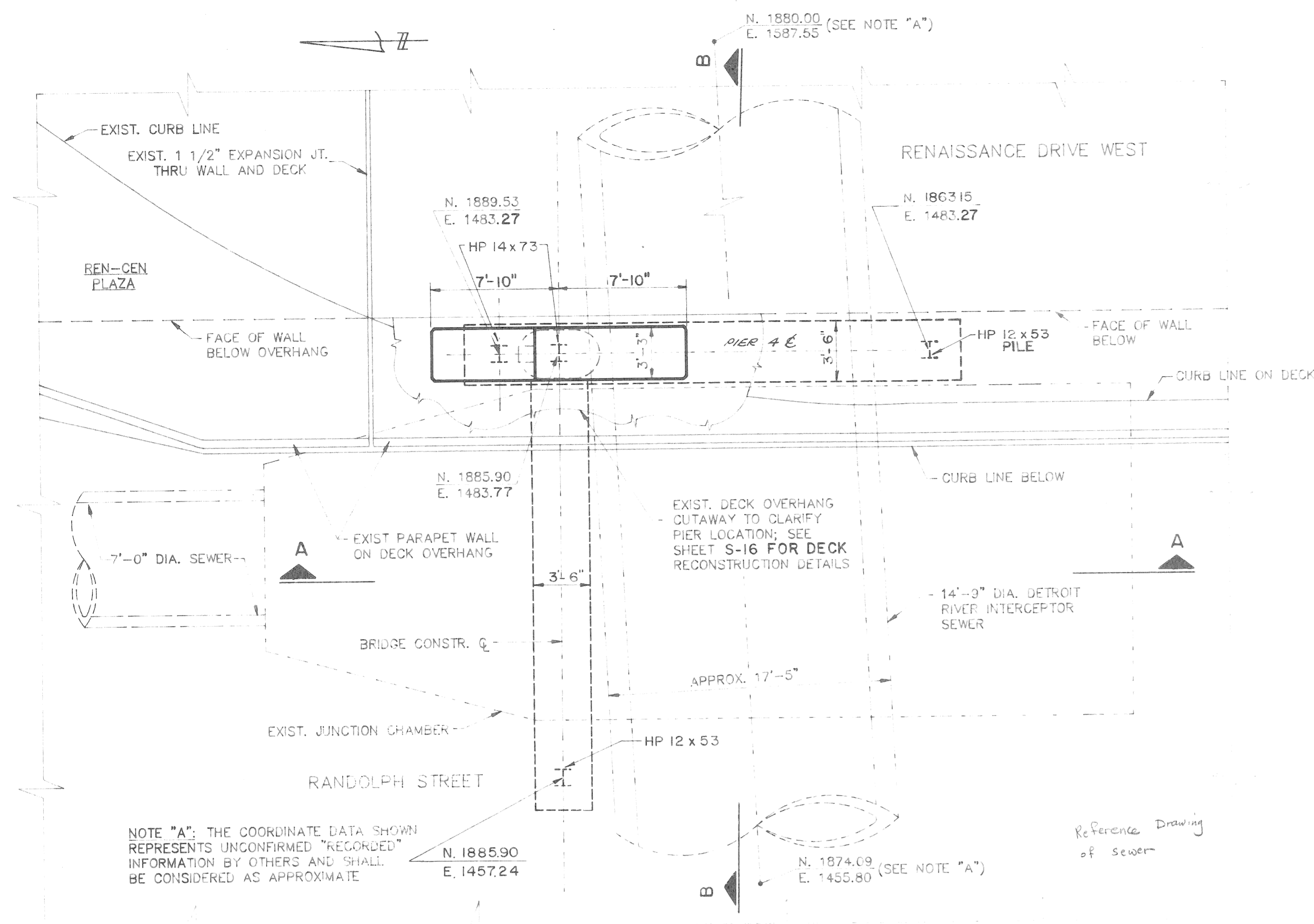

DATE: 11/15/08	REVISION: 1
COMPILED BY: B.M.M.	DRAWN BY: B.M.M.
CHECKED BY: P.A.	DESIGN BY: K.C.H./S.O.
PROJECT NO. 8612	DATE: NOVEMBER, 2008
SHEET NO. S-4	PROJECT NO. 8612
CITY OF DETROIT CITY ENGINEERING DEPARTMENT CITY BRIDGE No. BP-27 PROJECT: RANDOLPH STREET PEDESTRIAN BRIDGE SHEET TITLE: PIER 4 DETAILS	
MADISON MADISON INTERNATIONAL OF MICHIGAN Engineers, Architects, Planners 1420 Washington Blvd. Detroit, Michigan 48226	
BHAU PATEL ENGINEER No. 28253 PROFESSIONAL ENGINEER	

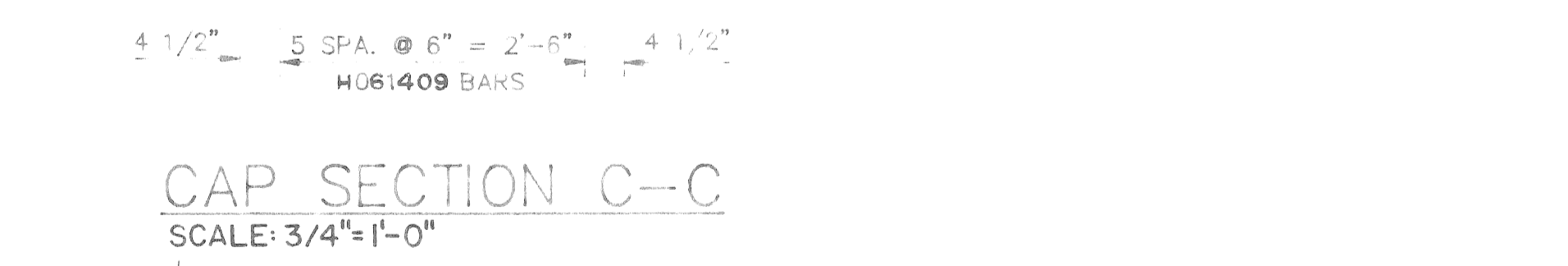
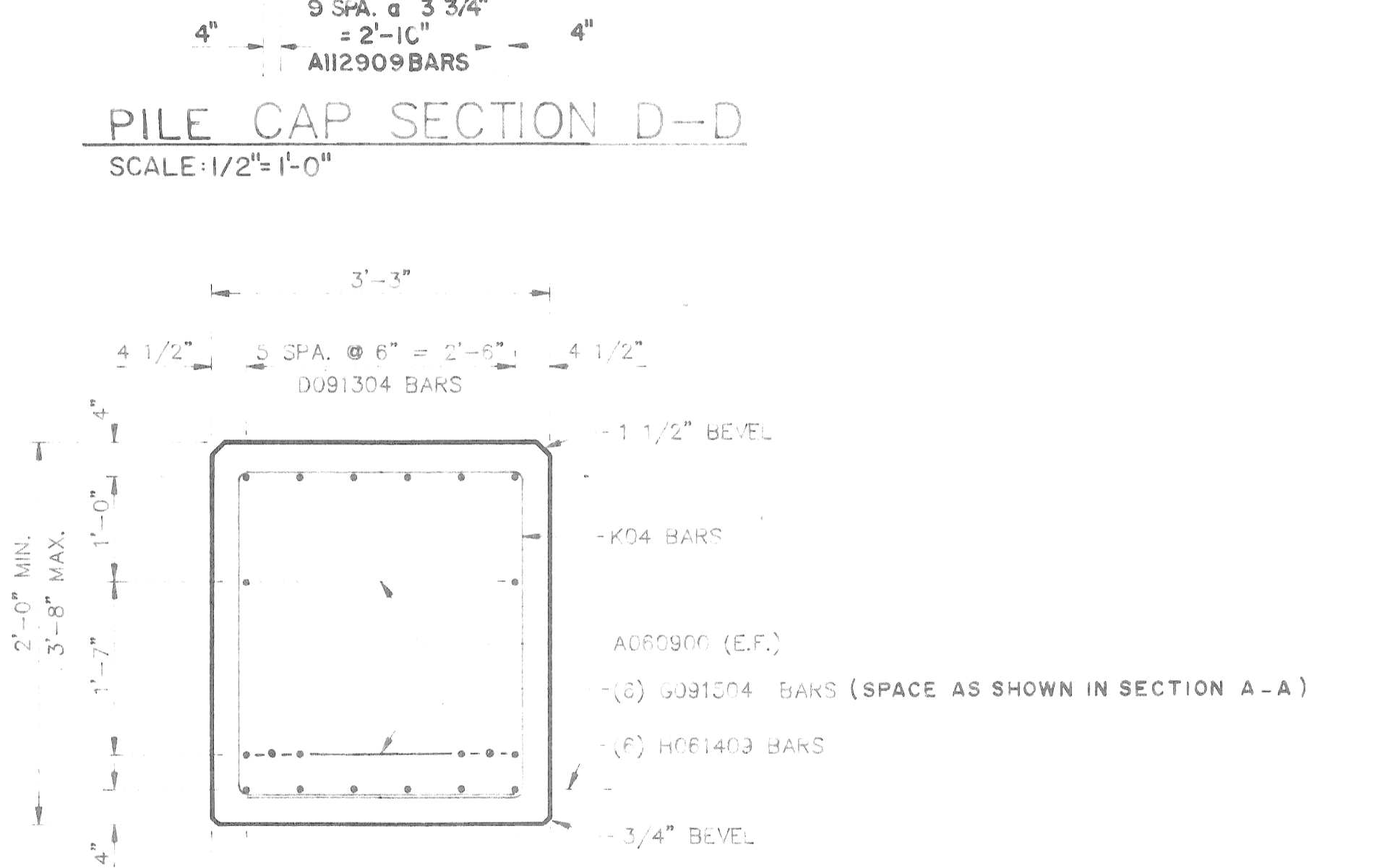
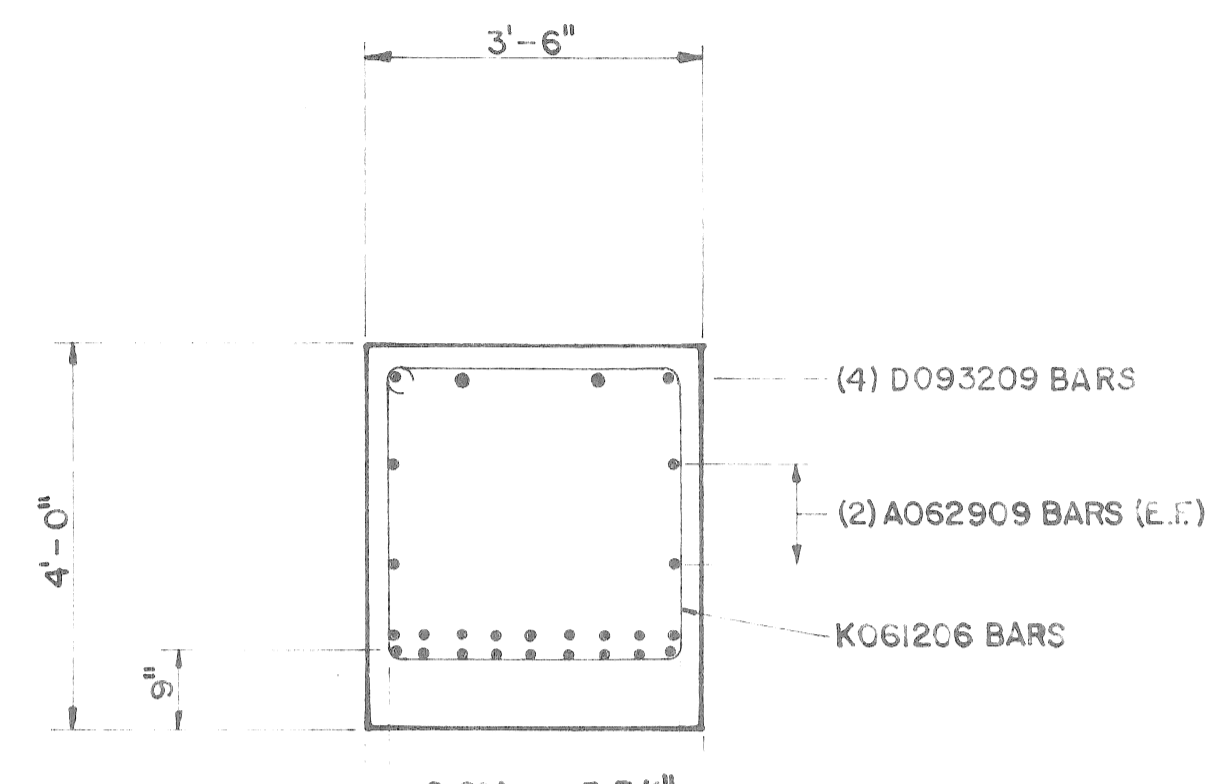
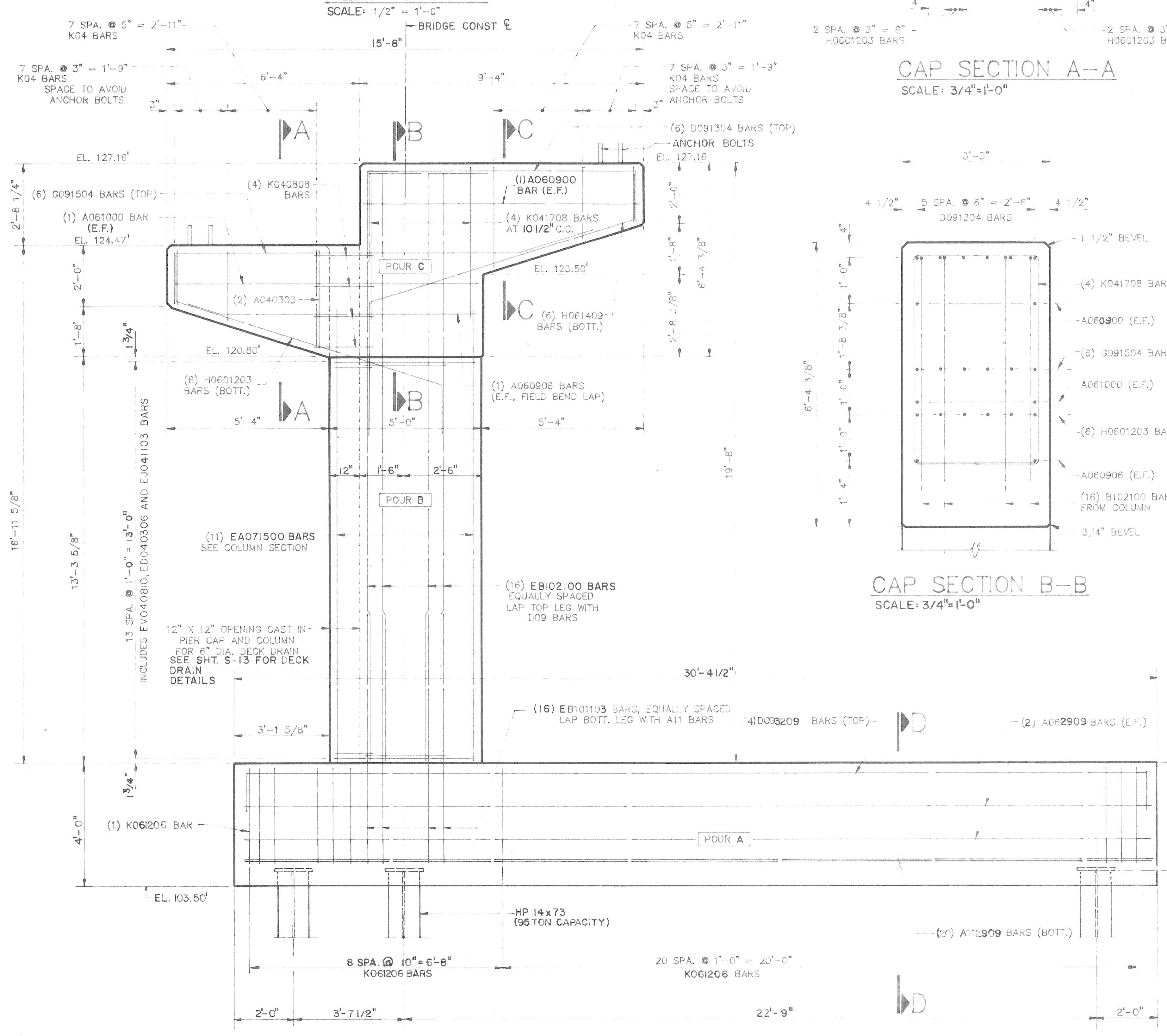
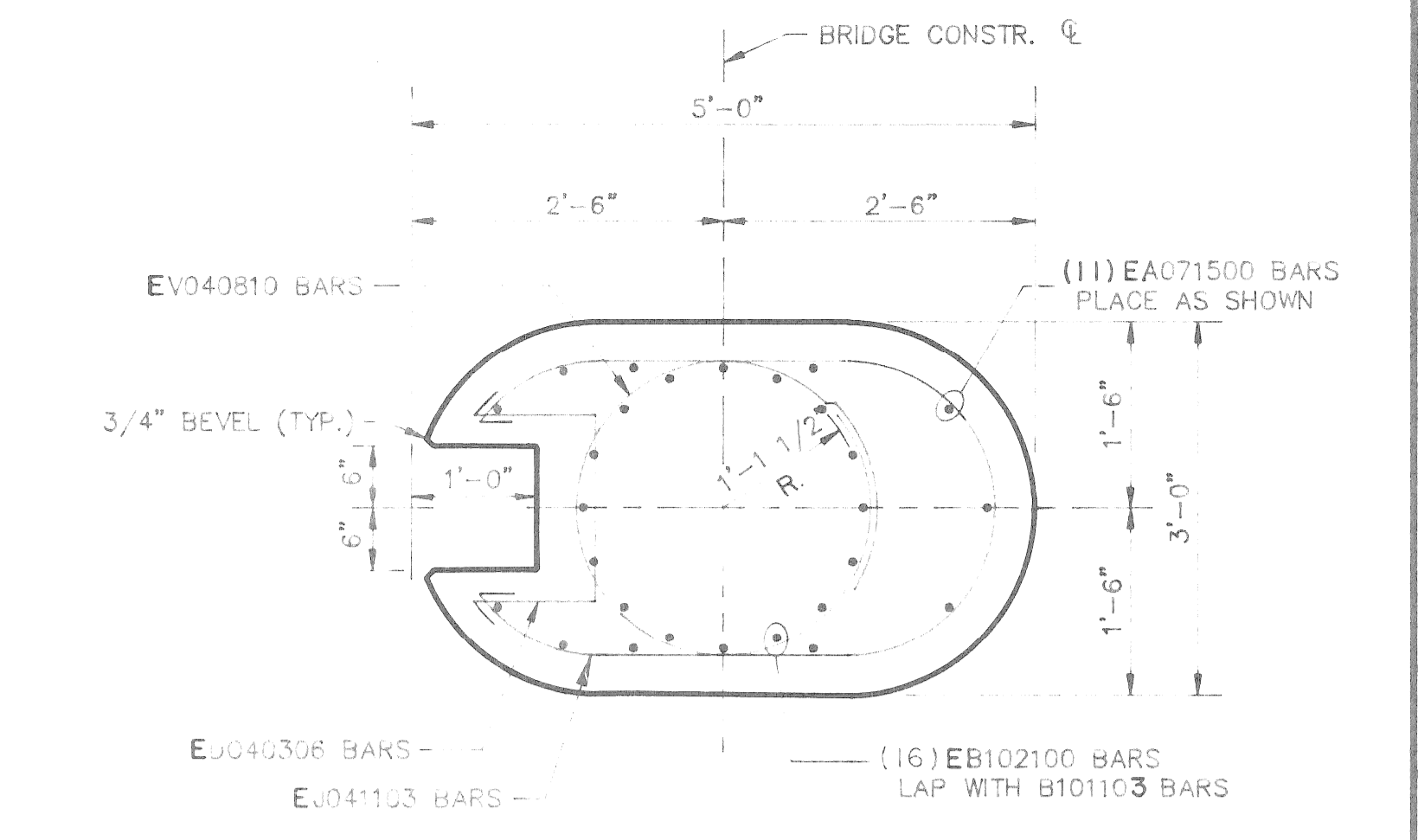
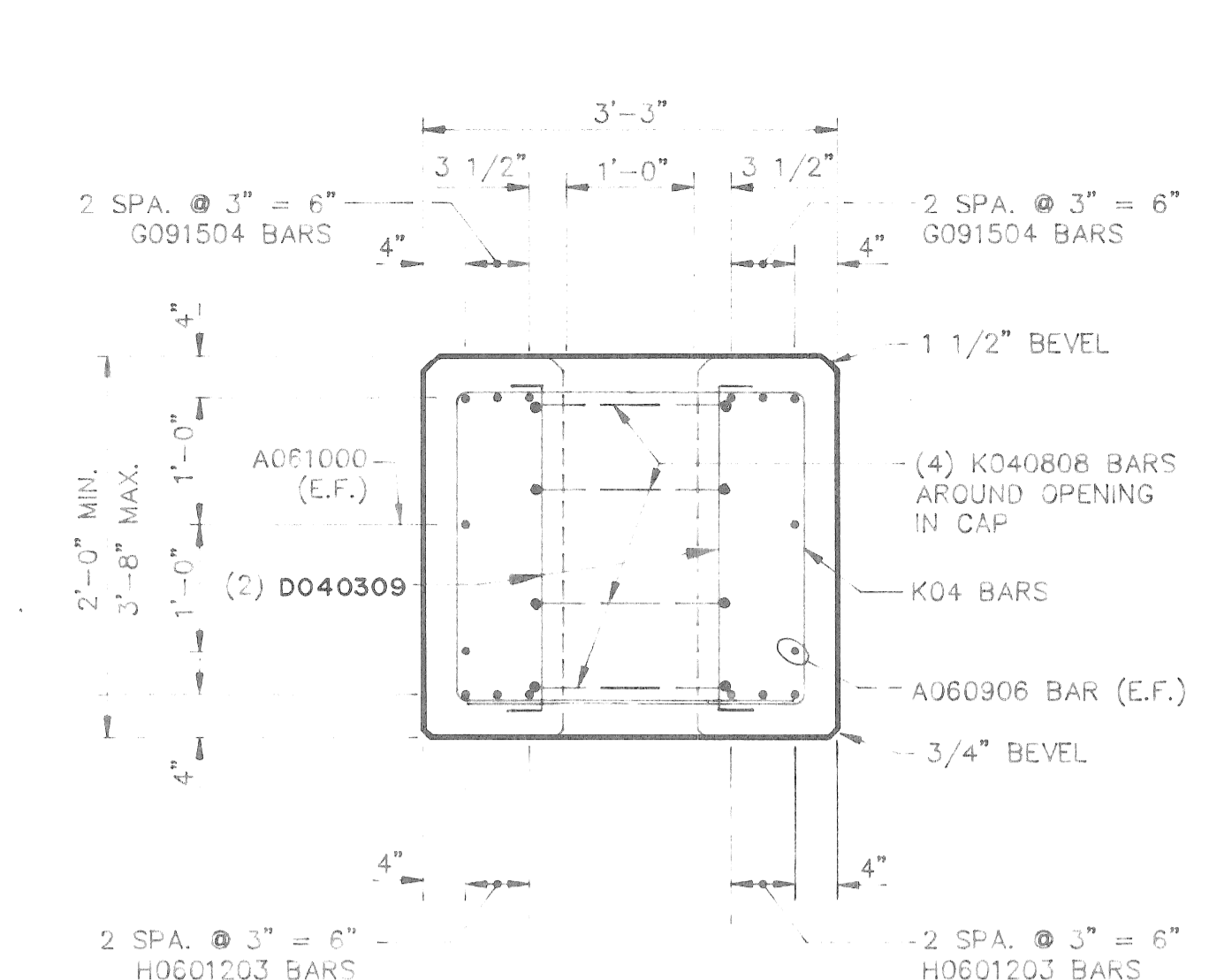
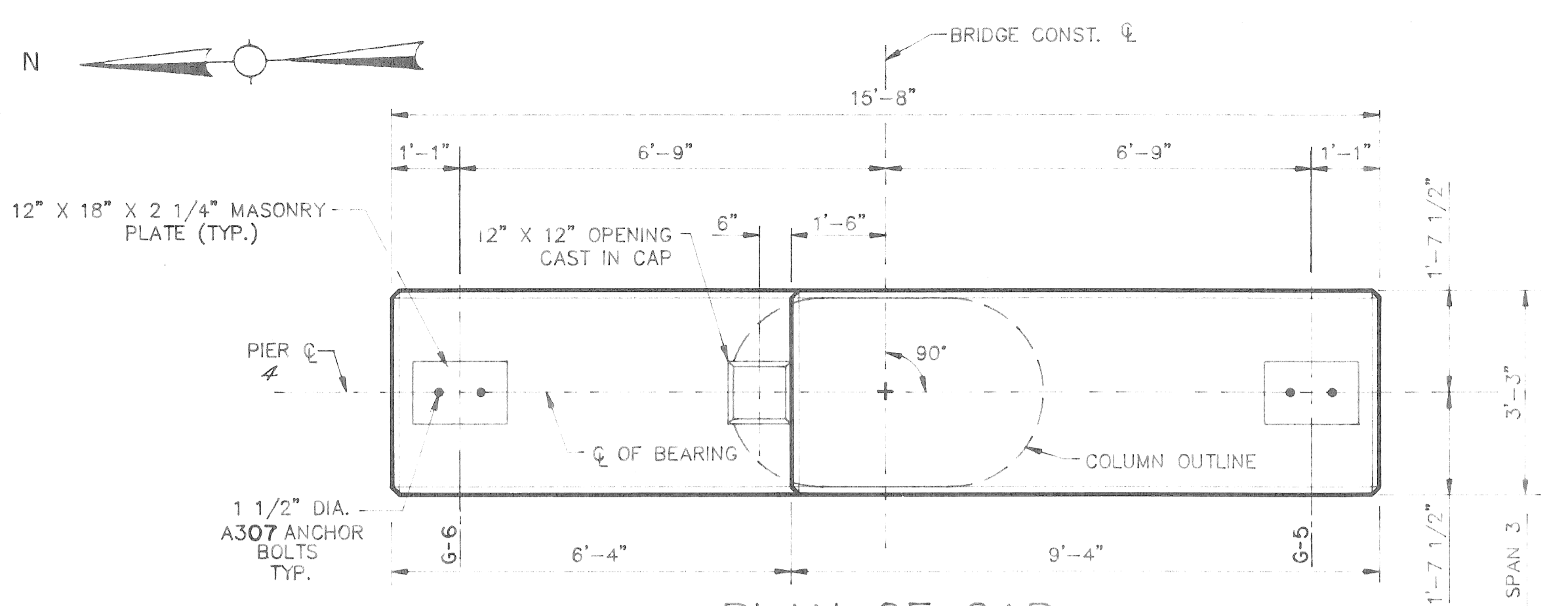

NOTE:
FOR ANCHOR BOLT DETAILS SEE SHEET S-10

SUBSTRUCTURE CONCRETE QUANTITIES

PIER 4

POUR	LOCATION	AMOUNT (CU. YD.)
A	PILE CAP	7.5
B	COLUMN	6.0
C	COLUMN CAP	7.2
TOTAL CONCRETE:		40.7 CU. YD.

REVISION

DATE

CITY OF DETROIT

CITY ENGINEERING DEPARTMENT

CITY BRIDGE No. BP-27

PROJECT: RANDOLPH STREET PEDESTRIAN BRIDGE

SHEET TITLE: PIER 4 DETAILS

MADISON / MADISON INTERNATIONAL OF MICHIGAN

Engineers, Architects, Planners
1420 Washington Blvd.
Detroit, Michigan 48226

DESIGN BY: K.C.H./S.O.

DRAWN BY: B.M.M.

CHECKED BY: P.A.

DATE: NOVEMBER, 89

PROJECT NO.: 8612

SHEET NO.: S-5

STATE OF MICHIGAN
BHAJU PATEL
ENGINEER
No. 28253

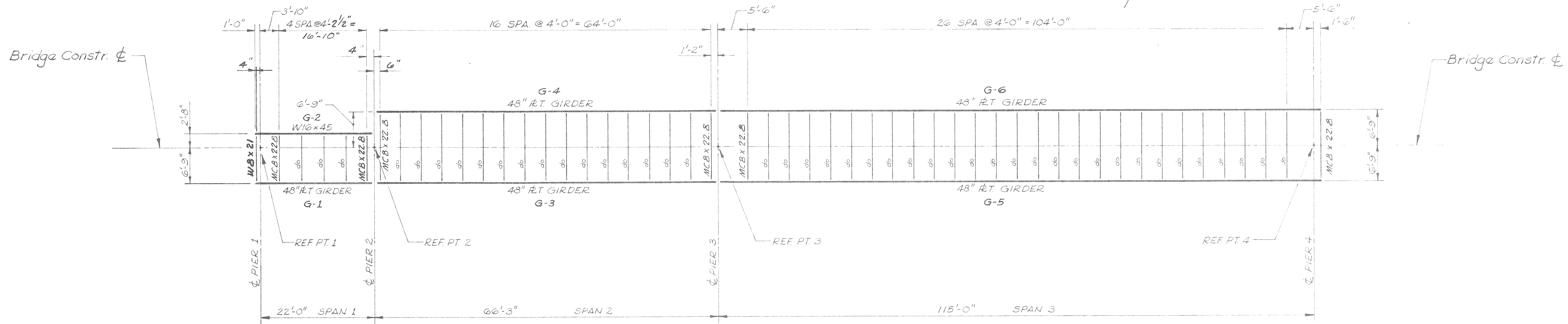

ERECTION DIAGRAM
N.T.S.

GIRDER / BEAM SCHEDULE	
MARK	SIZE
G-1	FLANGE (T & B): 7/8" x 16" WEB: 3/8" x 48"
G-2	W16 x 45
G-3	FLANGE (T & B): 7/8" x 16"
G-4	WEB: 3/8" x 48"
G-5	FLANGE (T & B): SEE SHEET S-7
G-6	WEB: 3/8" x 48"

GENERAL NOTES:

DESIGN LOADING
WINDLOAD ON STRUCTURE: 50 PSF ON VERTICAL PROJECTION
DEFLECTION - 1/1000 OF SPAN FOR LIVE LOAD. DECK LIVE LOAD SHALL BE IN ACCORDANCE WITH AASHTO STANDARD SPECIFICATIONS FOR HIGHWAY BRIDGES. ASSUMED LIVE LOAD = 100 PSF.
DESIGN CRITERIA - AASHTO STANDARD SPECIFICATIONS FOR HIGHWAY BRIDGES, CURRENT EDITION.
AASHTO GUIDE SPECIFICATIONS FOR FRACTURE CRITICAL NON-REDUNDANT STEEL BRIDGE MEMBERS, 1979. FRACTURE CRITICAL MEMBERS (FCM's) OR COMPONENTS OF MEMBERS ARE DESIGNATED ON THE DRAWINGS WITH THE SYMBOL \otimes . NOTE ALL ROLLED SECTIONS WITH AT LEAST 1/4" DEPTH ARE CONSIDERED FCM's.
MATERIALS - STRUCTURAL STEEL: PER MDOT, 1984 STANDARD SPECIFICATIONS, DIVISION 8. ALL MATERIAL ASTM A36.
CONCRETE:
28 DAYS COMPRESSIVE STRENGTH -
CAISSON, CAPS AND PILE CAPS: 5000 PSI specification?
PIER COLUMNS AND CAPS = 4500 PSI (MDOT 45D)
DECK SLABS = 4500 PSI (MDOT 45D)
PENETRATING SEALANT SHALL BE APPLIED TO SLAB AND STEPS.
REINFORCEMENT:
PER MDOT, 1984 STANDARD SPECIFICATION, DIVISION 8:
REINFORCING STEEL IN DECK AND WALLS ETC. SHALL BE EPOXY COATED.
VERTICAL REINFORCEMENT IN COLUMNS AND CAISSONS: ASTM A615 GRADE 60
DECK SLAB REINFORCEMENT: ASTM A615 GRADE 60
MESH: ASTM A185
TIES: ASTM A615 GRADE 40
SOIL BEARING PRESSURES USED IN DESIGN: CAISSONS - 50 KSF (25 TONS/SF)
SEE SOIL BORING LOGS, SHEET S-14

STRUCTURAL STEEL

WELDING, TESTING & INSPECTION OF STRUCTURAL STEEL - MDOT 1984 STANDARD SPECIFICATIONS FOR CONSTRUCTION & MDOT SPECIAL PROVISIONS FOR FABRICATING STRUCTURAL STEEL & ALUMINUM, AS MODIFIED BY THE SPECIAL PROVISIONS FOR STRUCTURAL STEEL. THE AASHTO GUIDE SPECIFICATIONS FOR FRACTURE CRITICAL NON-REDUNDANT STEEL BRIDGE MEMBERS SHALL TAKE PRECEDENCE OVER THE ABOVE, WHERE THE AASHTO REQUIREMENTS ARE MORE STRINGENT THAN THE PRECEDING SPECIFICATIONS.
FIELD CONNECTIONS - SHALL BE BOLTED WITH 3/4-IN. DIAMETER HIGH STRENGTH BOLTS, EXCEPT AS NOTED. HIGH STRENGTH STEEL BOLTS, NUTS AND WASHERS, SHALL CONFORM TO ASTM A-325, TYPE 1, GALVANIZED.
CAMBER - GIRDERS SHALL BE CAMBERED FOR DEAD LOAD DEFLECTION IN ADDITION TO PERMANENT CAMBER DUE TO VERTICAL CURVATURE. HEATING SHALL BE USED, IF NECESSARY, TO ASSURE CAMBER PERMANENCY WITHIN TOLERANCE OF $\pm 1/4$ -IN. AT THE CENTER. THIS CAMBER SHALL BE MEASURED WITH THE BEAM LYING ON ITS SIDE.
PAINTING - ALL STRUCTURAL STEEL SHALL BE PAINTED IN ACCORDANCE WITH THE SPECIAL PROVISIONS.
STEEL - STRUCTURAL STEEL SHALL CONFORM TO ASTM A-36.
FABRICATION - SHALL BE IN ACCORDANCE WITH MICHIGAN DEPARTMENT OF STATE HIGHWAYS STANDARD SPECIFICATIONS FOR HIGHWAY CONSTRUCTION - 1984 EDITION.
SHOP ASSEMBLY - ALL MEMBERS WHETHER REAMED OR PUNCHED, SHALL BE ASSEMBLED AT THE FABRICATING PLANT, UNLESS OTHERWISE NOTED. ALL STEEL STRUCTURES HAVING REAMED FIELD CONNECTIONS SHALL BE ASSEMBLED, UNLESS OTHERWISE NOTED, BEFORE REAMING IS COMMENCED. ASSEMBLED STEEL STRUCTURES SHALL NOT BE KNOCKED DOWN UNTIL AFTER THE SHOP INSPECTION HAS BEEN MADE.
WELDING - THE MINIMUM SIZE OF WELD SHALL BE 5/16-IN. UNLESS OTHERWISE SHOWN ON THE PLANS. ALL WELDING SHALL BE DONE IN ACCORDANCE WITH A.W.S. SPECIFICATIONS.
WELDING ON THE TENSION FLANGES OF BEAMS SHALL NOT BE PERMITTED UNLESS SUCH WELDING IS SHOWN ON THE PLANS OR SPECIFIED. WELDING AT OTHER LOCATIONS ON THE BEAMS, EXCEPT WHERE SHOWN ON THE PLANS, MAY BE PERMITTED BY WRITTEN AUTHORIZATION PROVIDING THE WELDING IS PERFORMED IN STRICT ACCORDANCE WITH ALL SPECIFICATION REQUIREMENTS FOR STRUCTURAL WELDING.
ALL FIELD SPLICES WILL BE BOLTED. THE CONTRACTOR SHALL SUBMIT ANY PROPOSED FIELD SPLICE LOCATIONS AND DESIGNS TO THE ENGINEER FOR APPROVAL.
THE STRUCTURAL STEEL FABRICATOR SHALL BE CERTIFIED UNDER THE AISC QUALITY CERTIFICATION PROGRAM AS A CATEGORY III PLANT (MAJOR STEEL BRIDGES).
TESTING TEMPERATURE FOR THE LONGITUDINAL CHARPY V-NOTCH IMPACT TEST (TABLE 8.1) SHALL BE 10°F FOR ALL COMPONENTS OF G-1 THROUGH G-6.

AASHTO S 10.21.4 through span girders need gusset or knee braces against lateral deformation

penetrating from deck steps

REVISION: _____
DATE: _____
CITY OF DETROIT
CITY ENGINEERING DEPARTMENT
CITY BRIDGE No. BP-27

Project: **RANDOLPH STREET PEDESTRIAN BRIDGE**
Sheet Title: **STRUCTURAL STEEL DETAILS**

MADISON MADISON INTERNATIONAL OF MICHIGAN
Engineers, Architects, Planners and Scientists
Detroit, Michigan 48226

DESIGN BY: KCH/ISO
DRAWN BY: C.V.B.
CHECKED BY: PA.
DATE: NOVEMBER, 89
PROJECT NO.: 8612
SHEET NO.: S-6

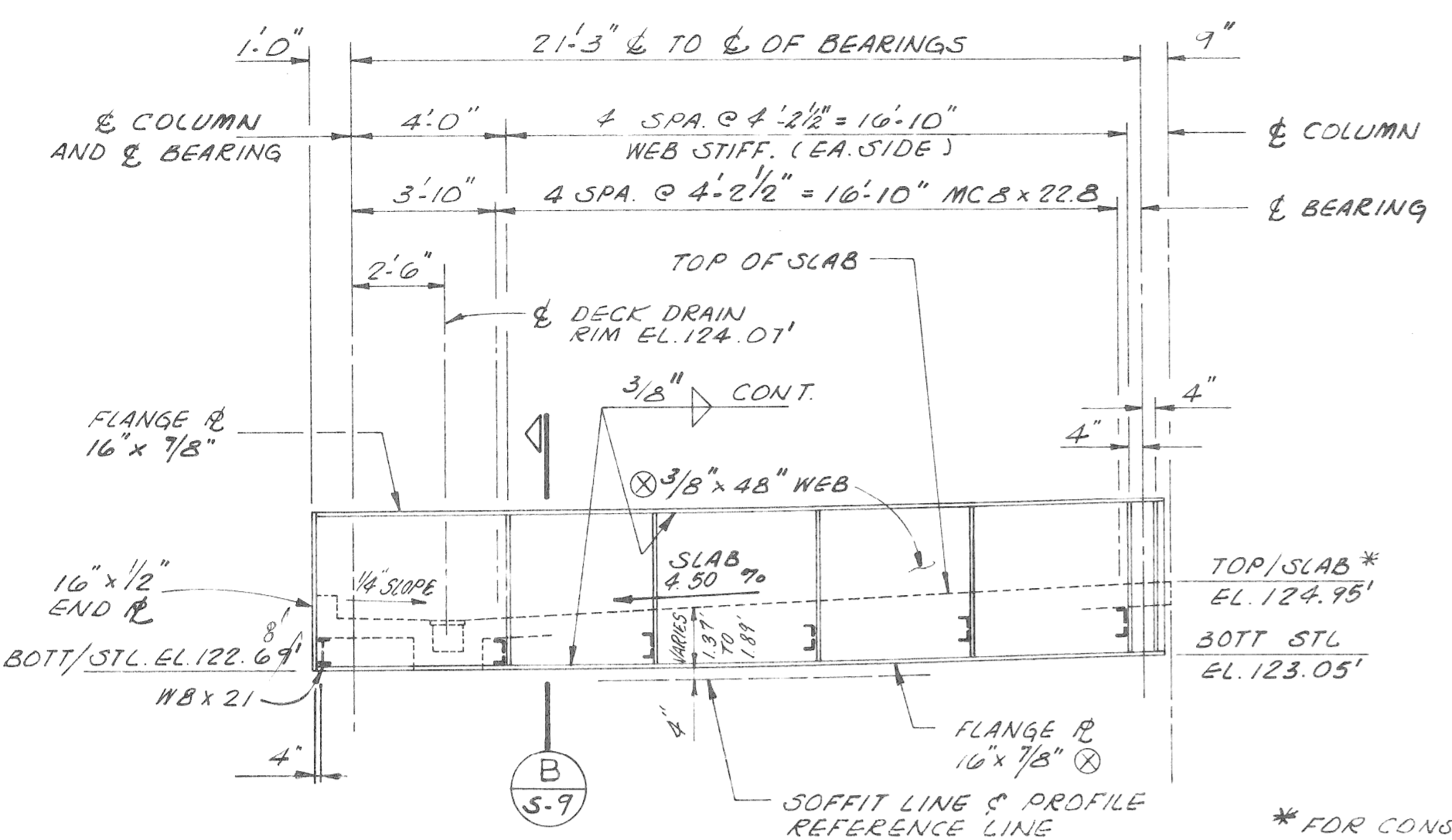

* FOR CONSTRUCTION JT. AT PIER 2 SEE DETAIL, SHEET S-19

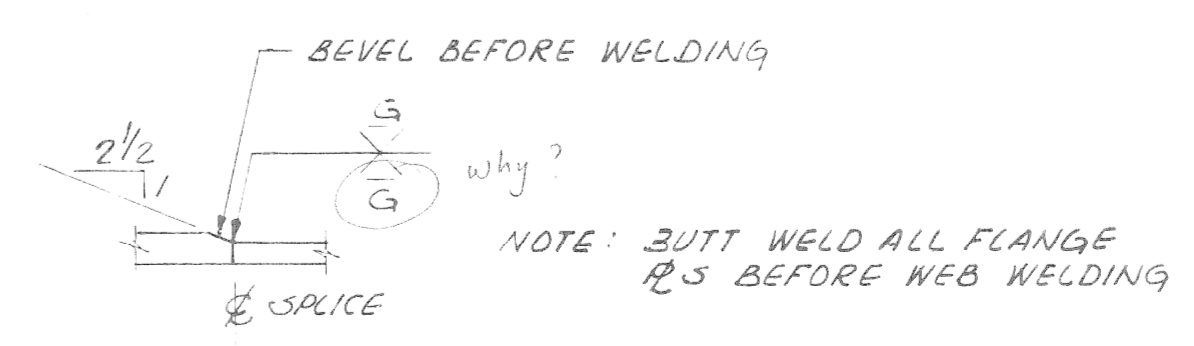
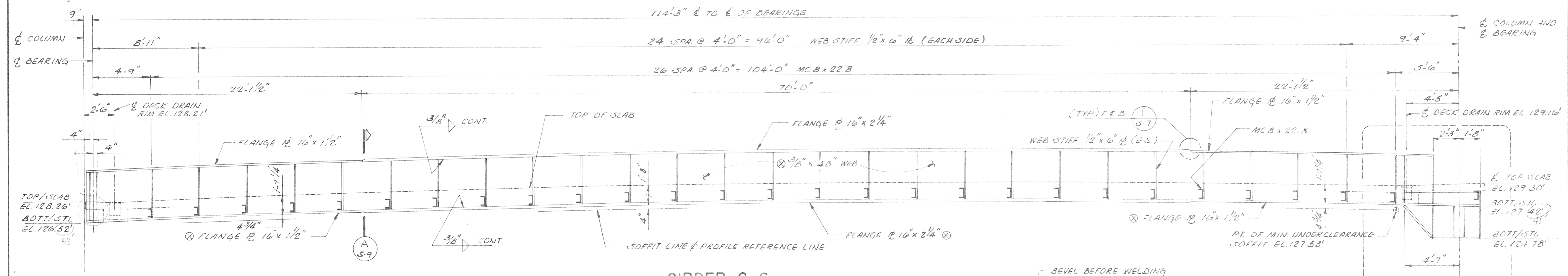
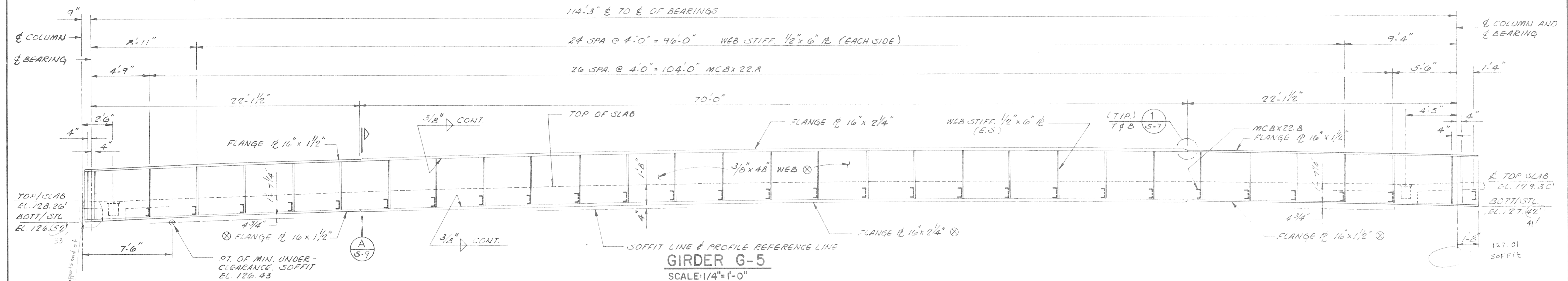
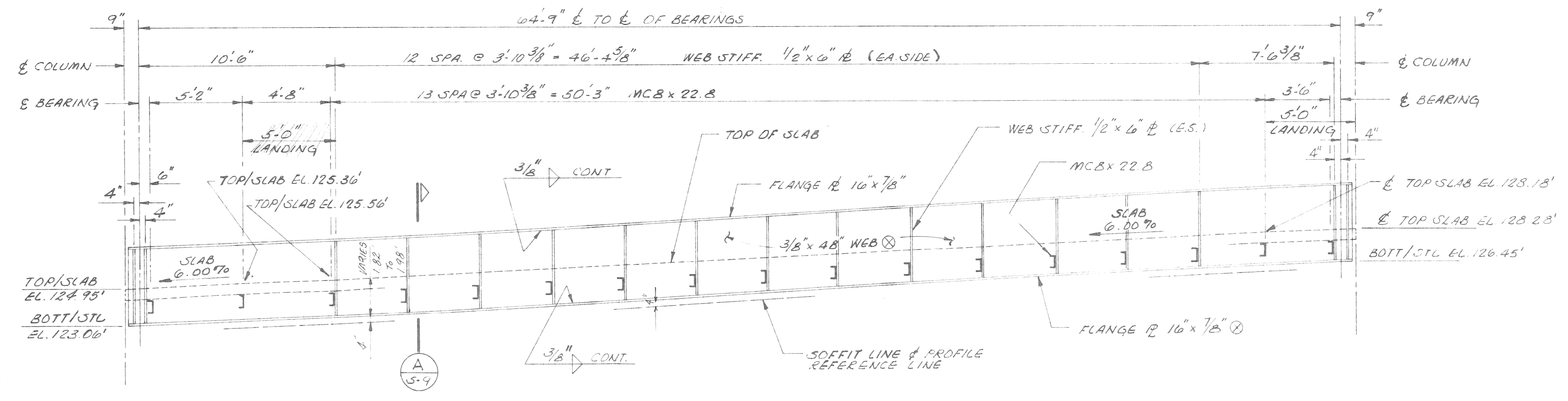

NOTE:
⊗ = FRACTURE CRITICAL MEMBER SEE DESIGN CRITERIA, SHT. S-6.

DATE	REVISION

CITY OF DETROIT
CITY ENGINEERING DEPARTMENT
CITY BRIDGE No. BP-27

RANDOLPH STREET PEDESTRIAN BRIDGE
STRUCTURAL STEEL DETAILS

MADISON INTERNATIONAL OF MICHIGAN
Engineers, Architects, Planners
1420 Washington Blvd.
Detroit, Michigan 48226

DESIGN BY: A.C.H./S.O.
DRAWN BY: C.V.B.
CHECKED BY: P.A.
DATE: NOVEMBER, 89
PROJECT NO.: 8612
SHEET NO.: S-7

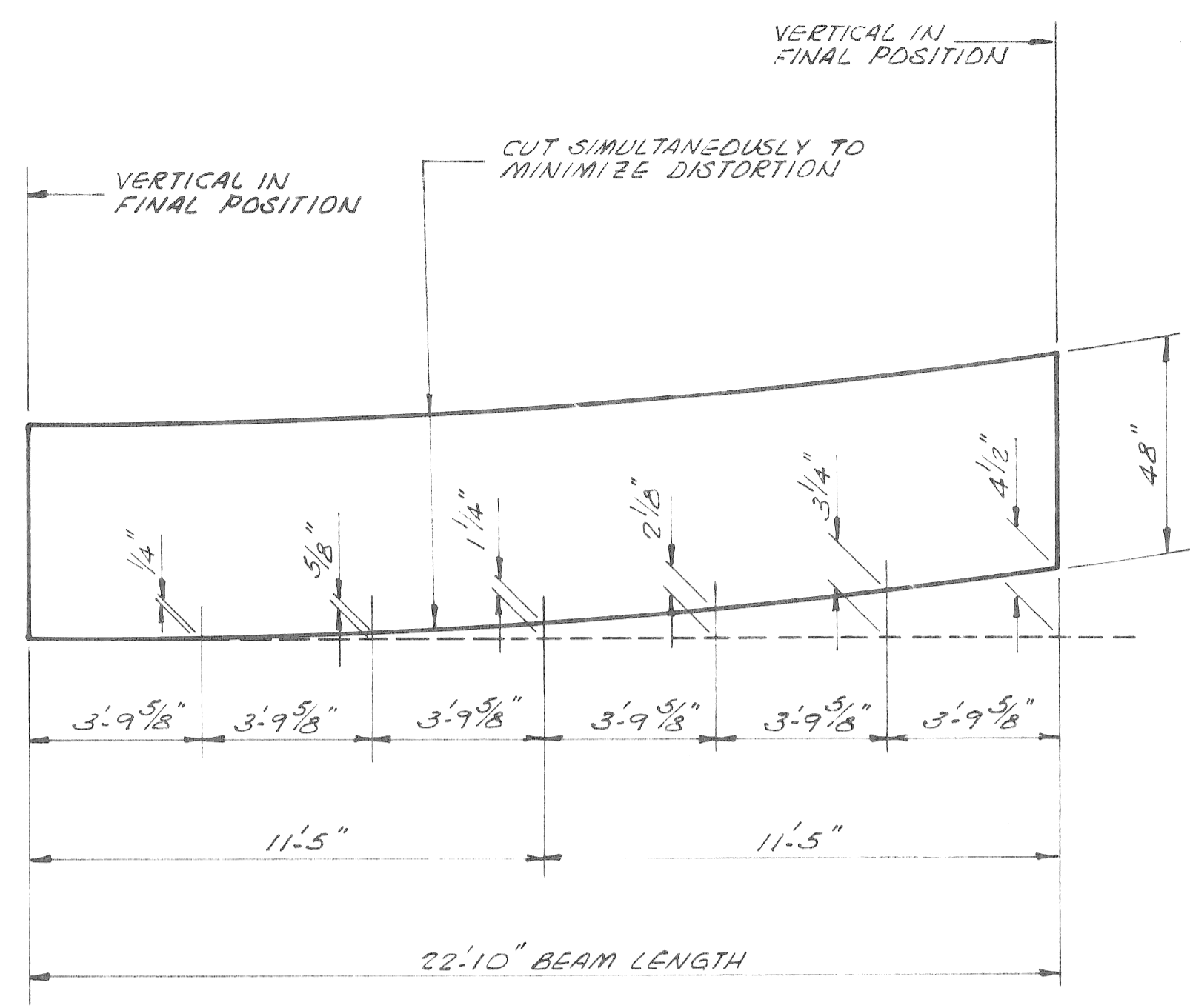

WEB CAMBER DIAGRAM - GIRDER G-1
 N.T.S.
 D.L. DEFLECTION AT MID SPAN = $\frac{1}{8}$ "

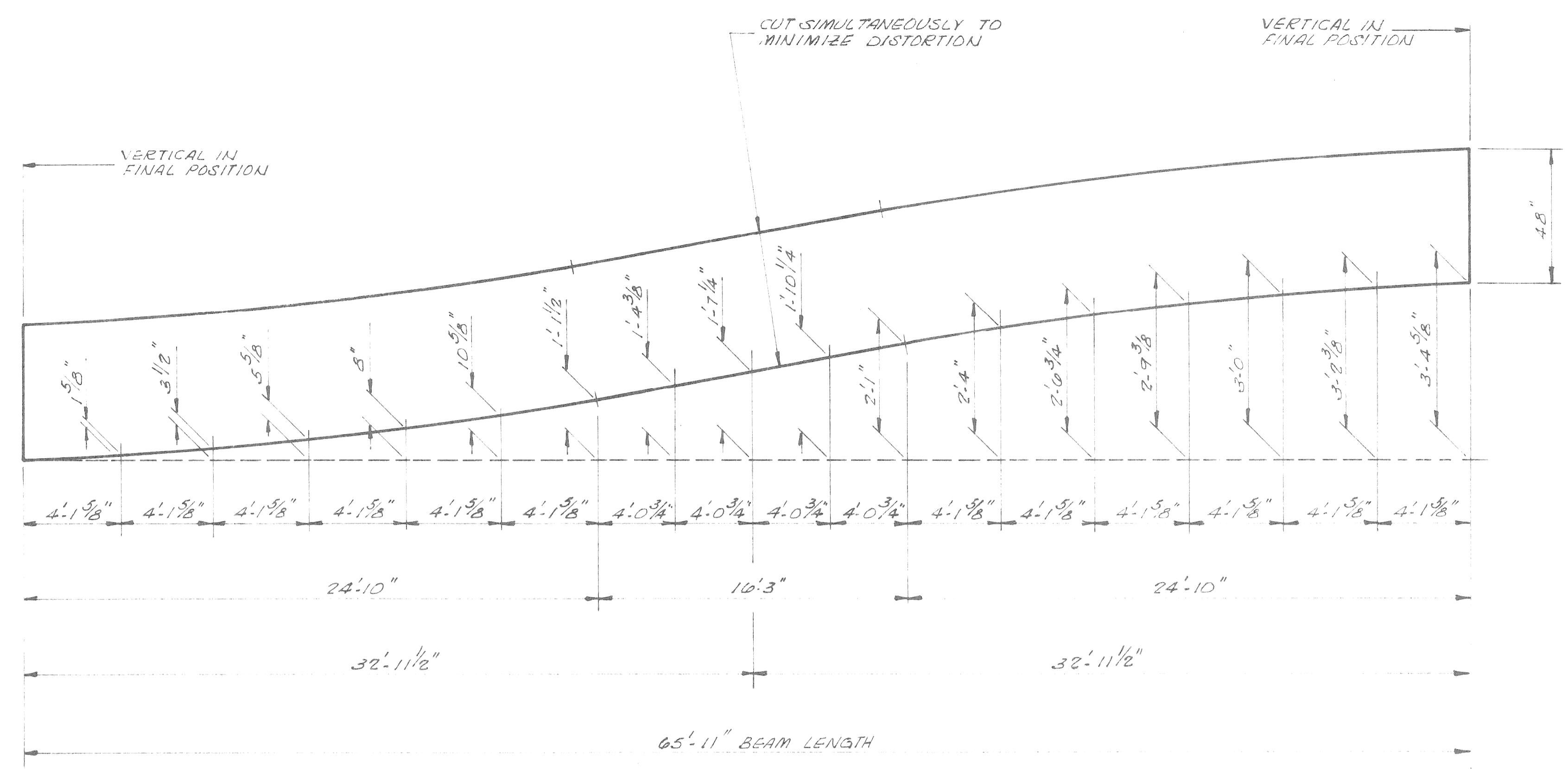

WEB CAMBER DIAGRAM - GIRDERS G-3 & G-4
 N.T.S.
 D.L. DEFLECTION AT MID SPAN = $\frac{5}{8}$ "

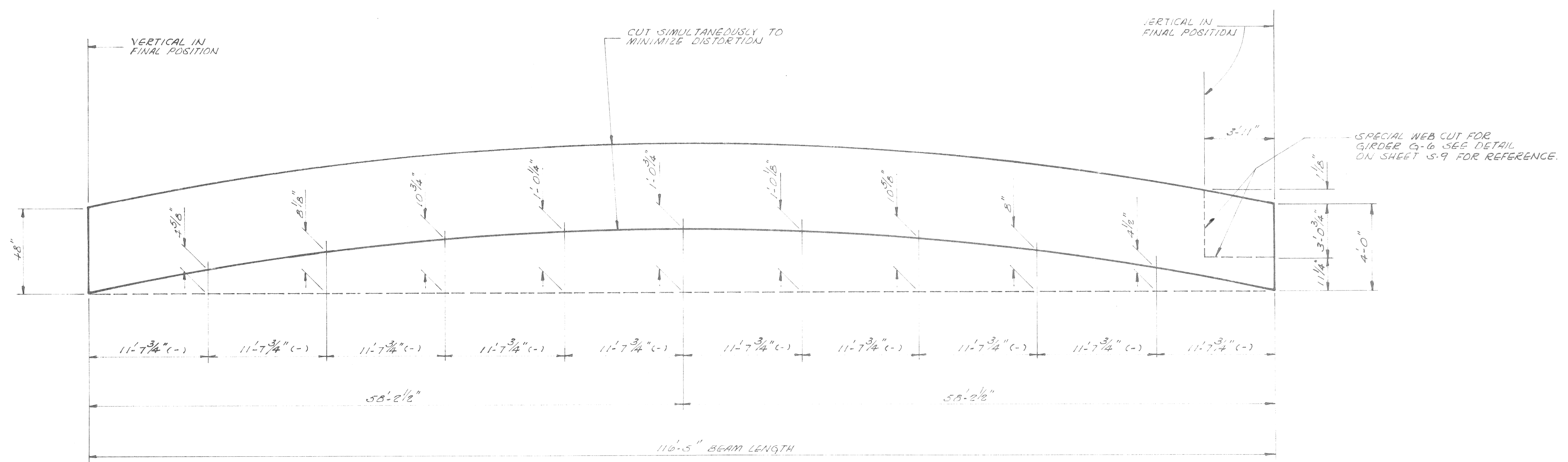

WEB CAMBER DIAGRAM - GIRDERS G-5 & G-6
 N.T.S.
 D.L. DEFLECTION AT MID SPAN = $\frac{3}{16}$ "

REVISIONS	DATE	BY	DESCRIPTION
CITY OF DETROIT CITY ENGINEERING DEPARTMENT CITY BRIDGE No. BP-27			
RANDOLPH STREET PEDESTRIAN BRIDGE		STRUCTURAL STEEL DETAILS	
Project	MADISON INTERNATIONAL OF MICHIGAN		
Sheet Title	Engineers, Architects, Planners 1420 Washington Blvd. Detroit, Michigan 48226		
DESIGN BY	K.C.H./S.D.		
DRAWN BY	C.V.B.		
CHECKED BY	P.A.		
DATE	NOVEMBER, 89		
PROJECT NO.	8612		
SHEET NO.	S-8		

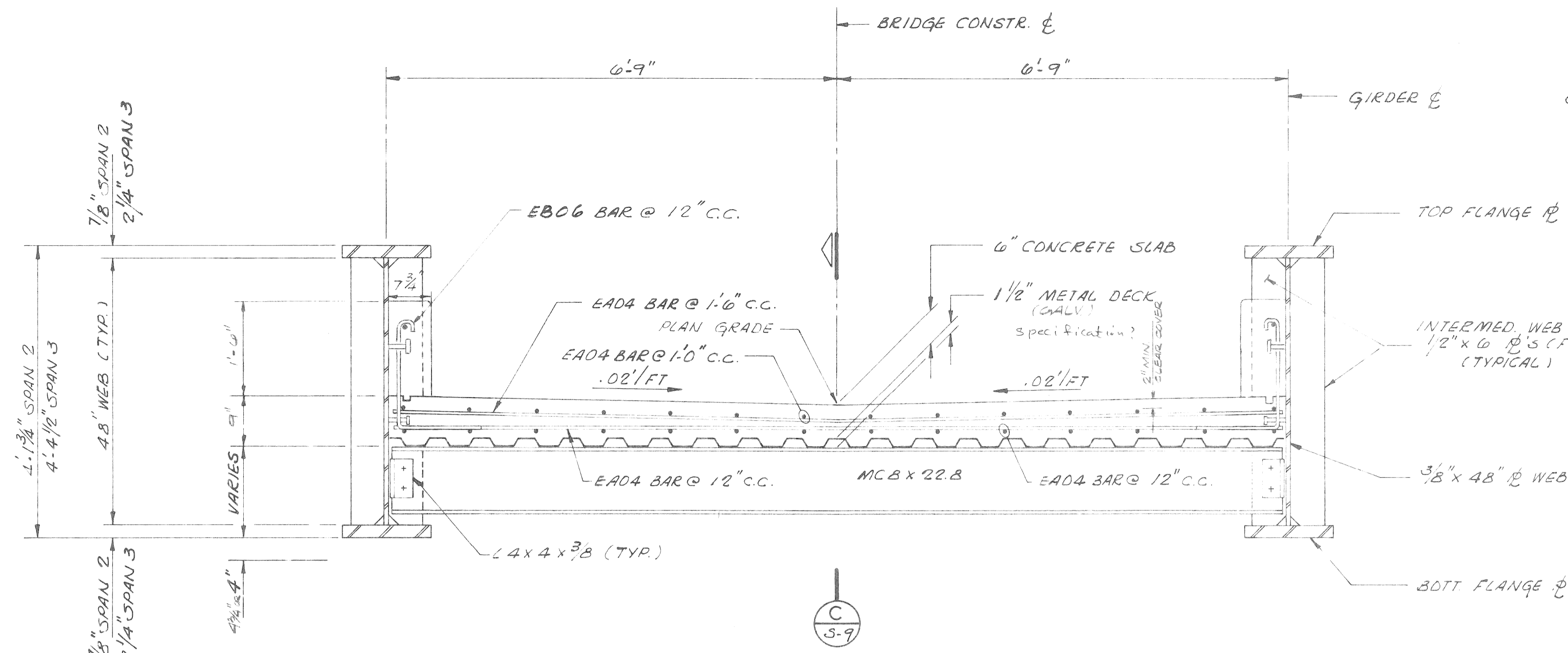

(A) TYPICAL DECK SECTION SPANS 2 AND 3
SCALE: 3/4"=1'-0"

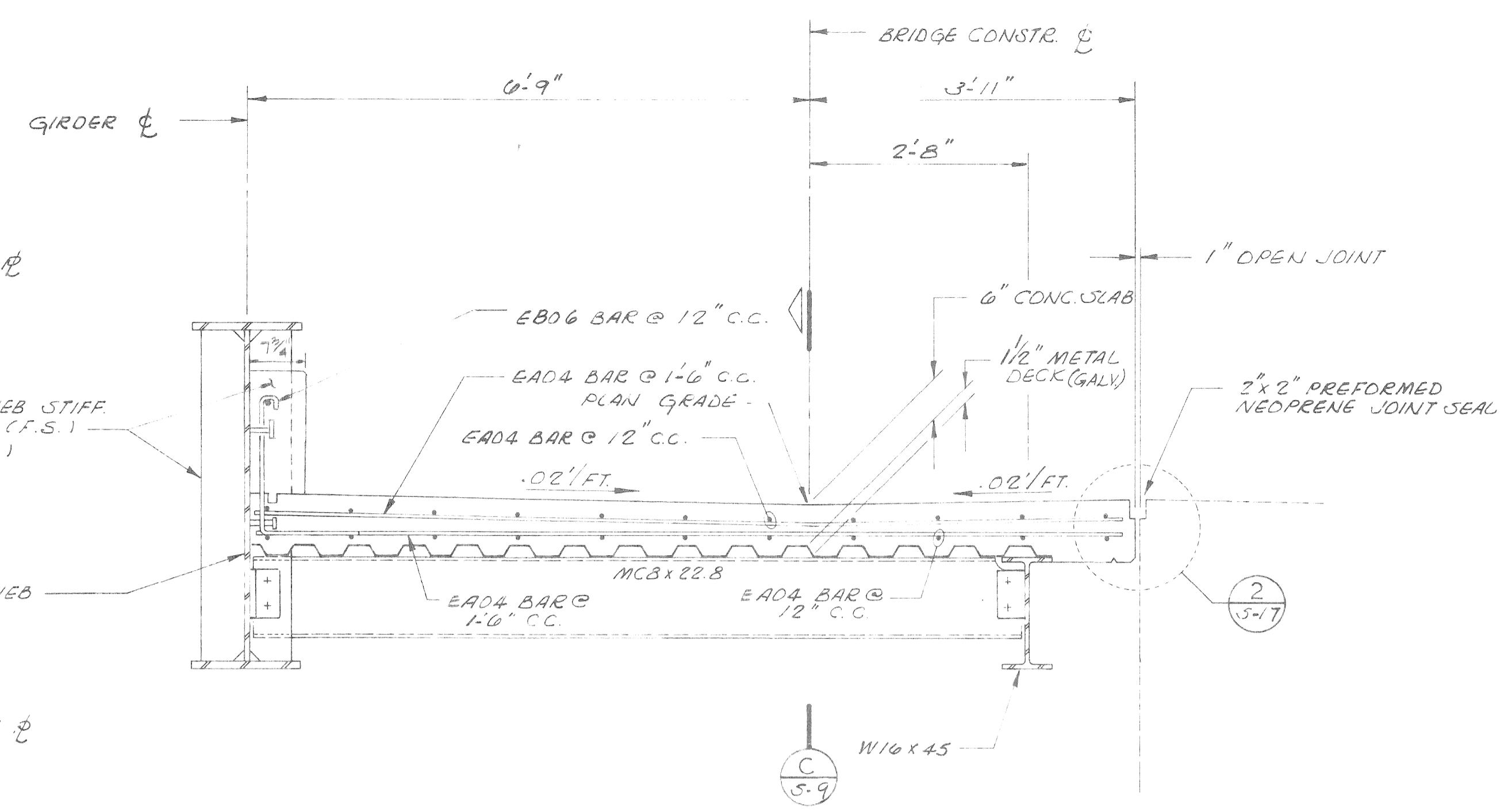

(B) TYPICAL DECK SECTION SPAN 1
SCALE: 3/4"=1'-0"

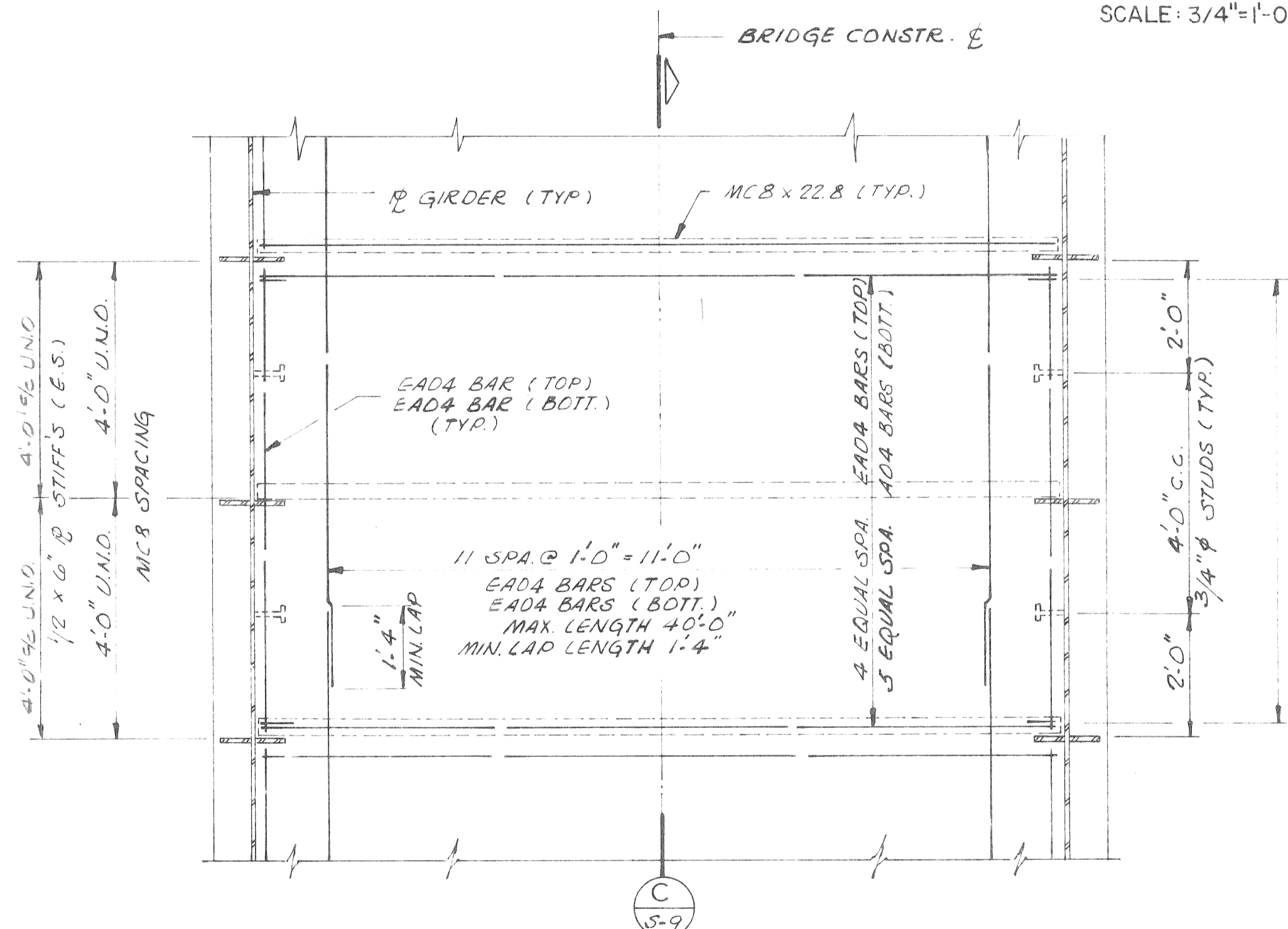

TYPICAL PLAN OF SLAB
SCALE: 1/2"=1'-0"

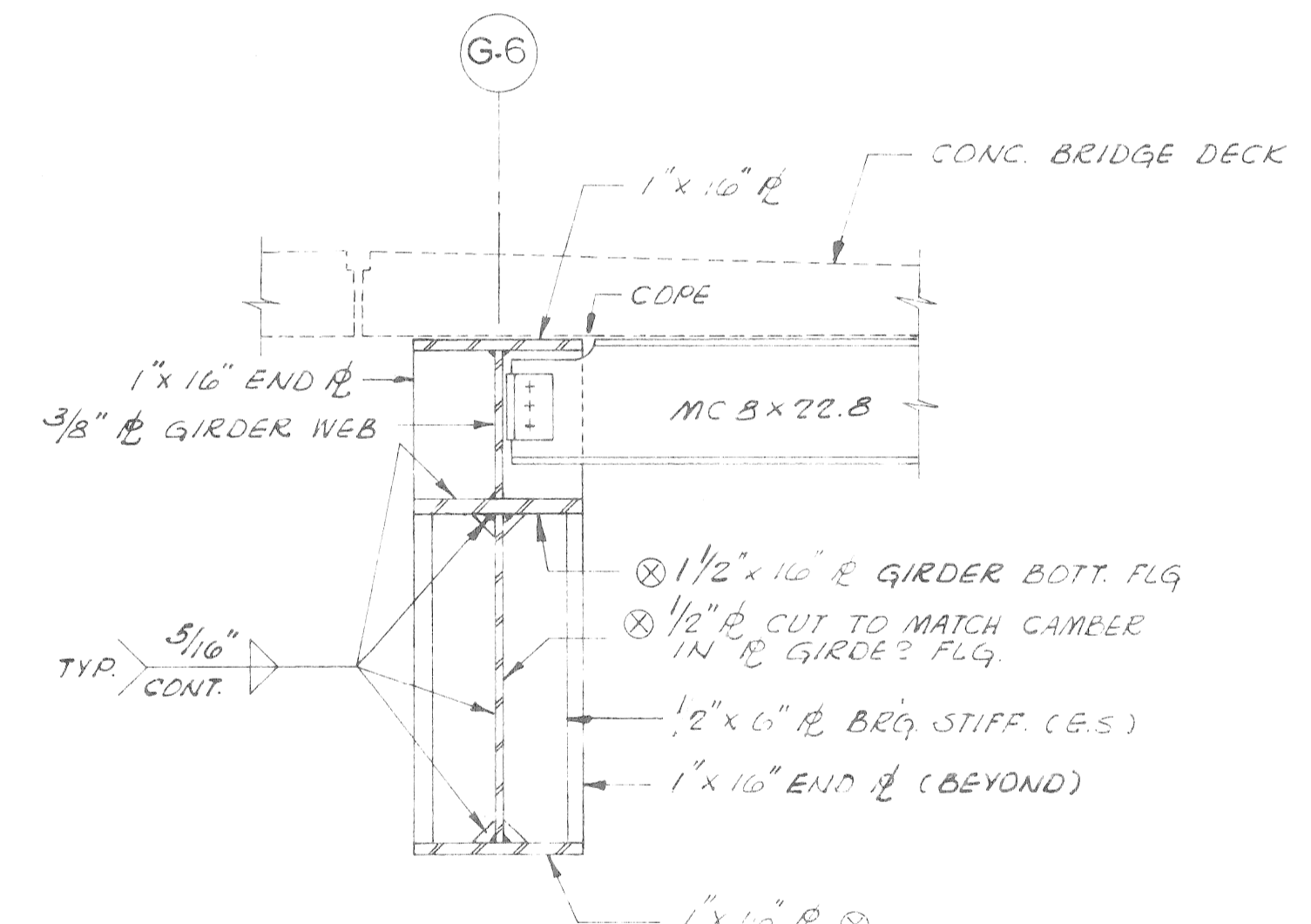

SECTION D
SCALE: 3/4"=1'-0"

1. STOP WELD 1/4" SHORT OF CORNER CLIPS.
2. WRAP WELD AROUND OUTSIDE EDGE.
3. WELDING OF METAL DECK TO MCB'S SHALL CONFORM TO METAL DECK MANUFACTURERS SPECIFICATIONS.

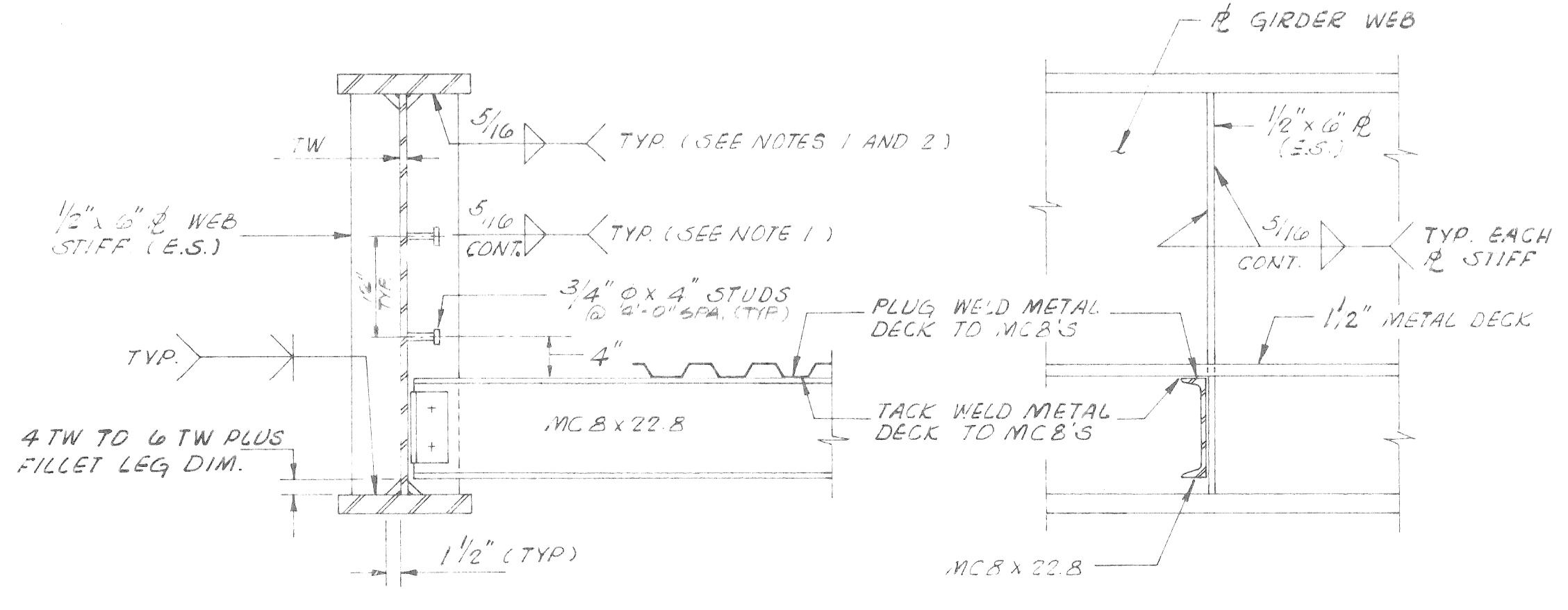

WEB STIFFENER WELD DETAILS
SCALE: 3/4"=1'-0"

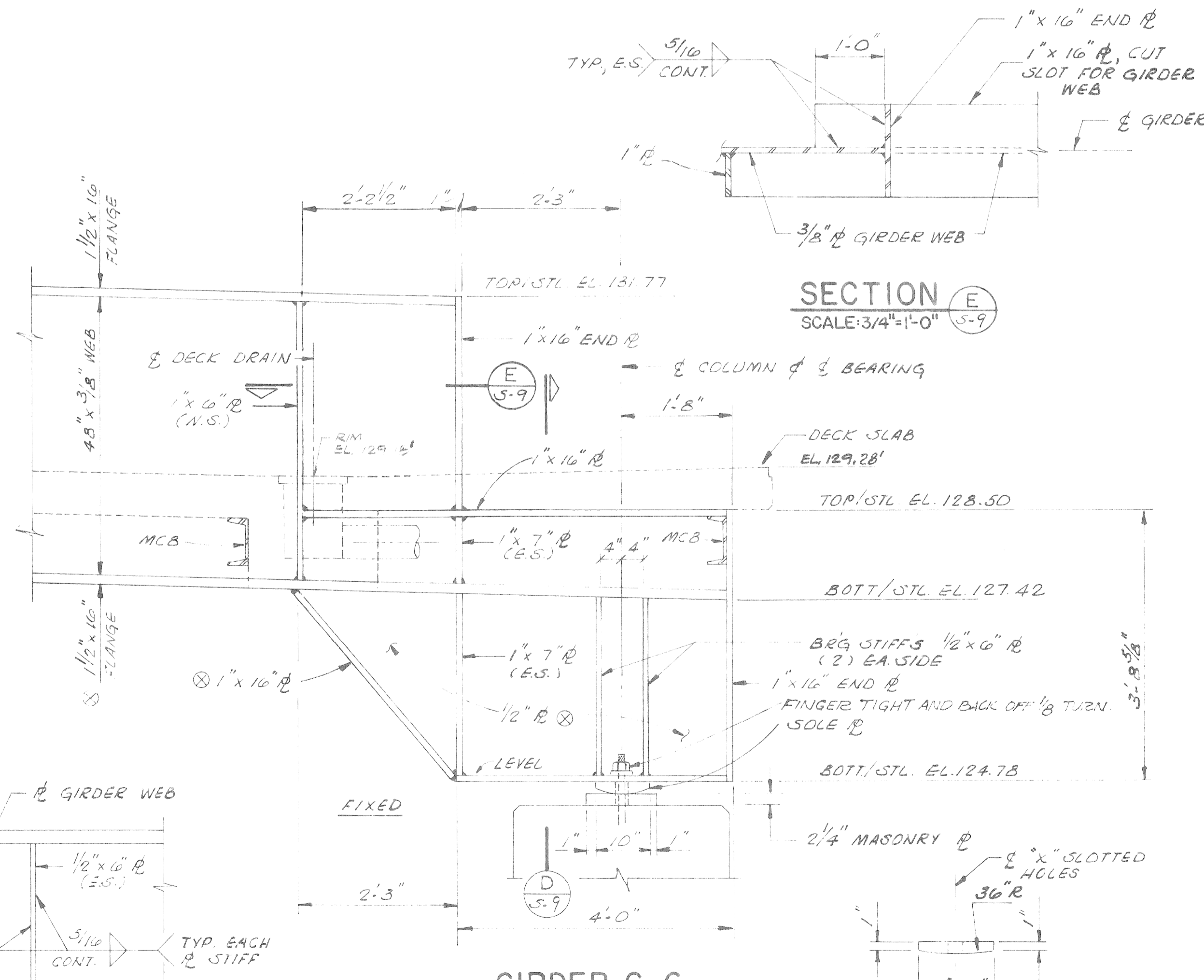

GIRDER G-6 END DETAIL
SCALE: 3/4"=1'-0"

SOLE PLATE FOR G-6 PIER 4
SCALE: 1"=1"

NOTE:
⊗ = FRACTURE CRITICAL MEMBER
SEE DESIGN CRITERIA SHT. 5-2

REVISION:	DATE:
CITY OF DETROIT	CITY ENGINEERING DEPARTMENT
CITY BRIDGE No. BP-27	
RANDOLPH STREET PEDESTRIAN BRIDGE SUPERSTRUCTURE AND STRUCTURAL STEEL DETAILS	
Project	Sheet Title
MADISON INTERNATIONAL OF MICHIGAN Engineers, Architects, Planners 1420 Washington Blvd. Detroit, Michigan 48226	DESIGN BY K.C.H./S.O. DRAWN BY C.V.B. CHECKED BY P.A. DATE NOVEMBER, 1971 PROJECT NO. 8612 SHEET NO. S-9

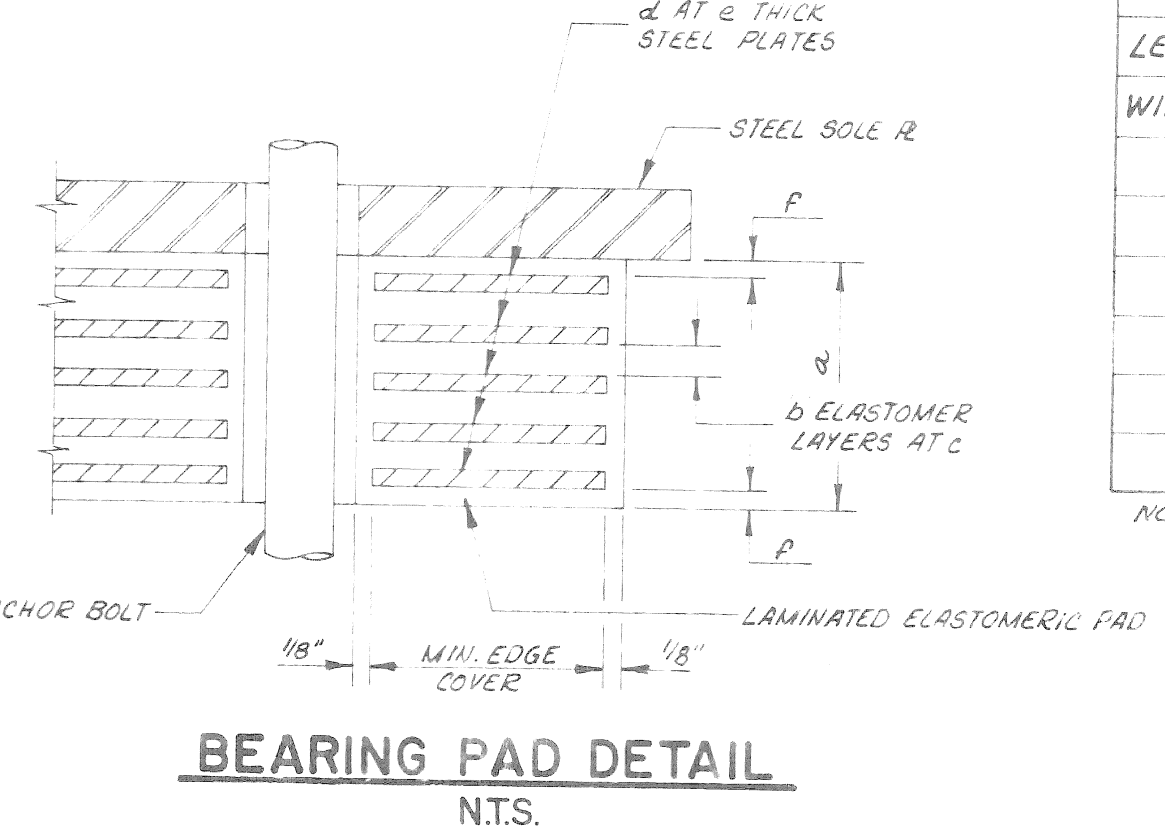
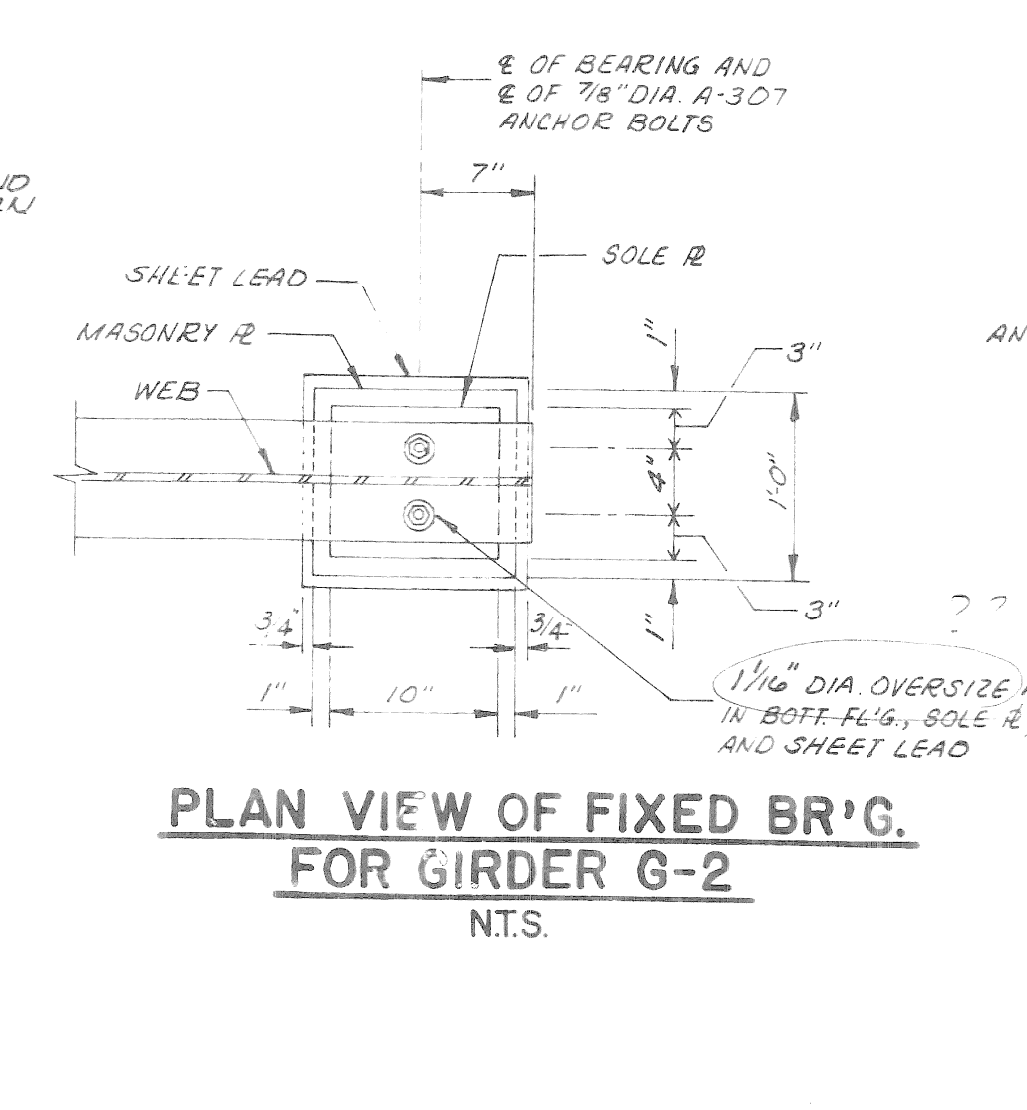
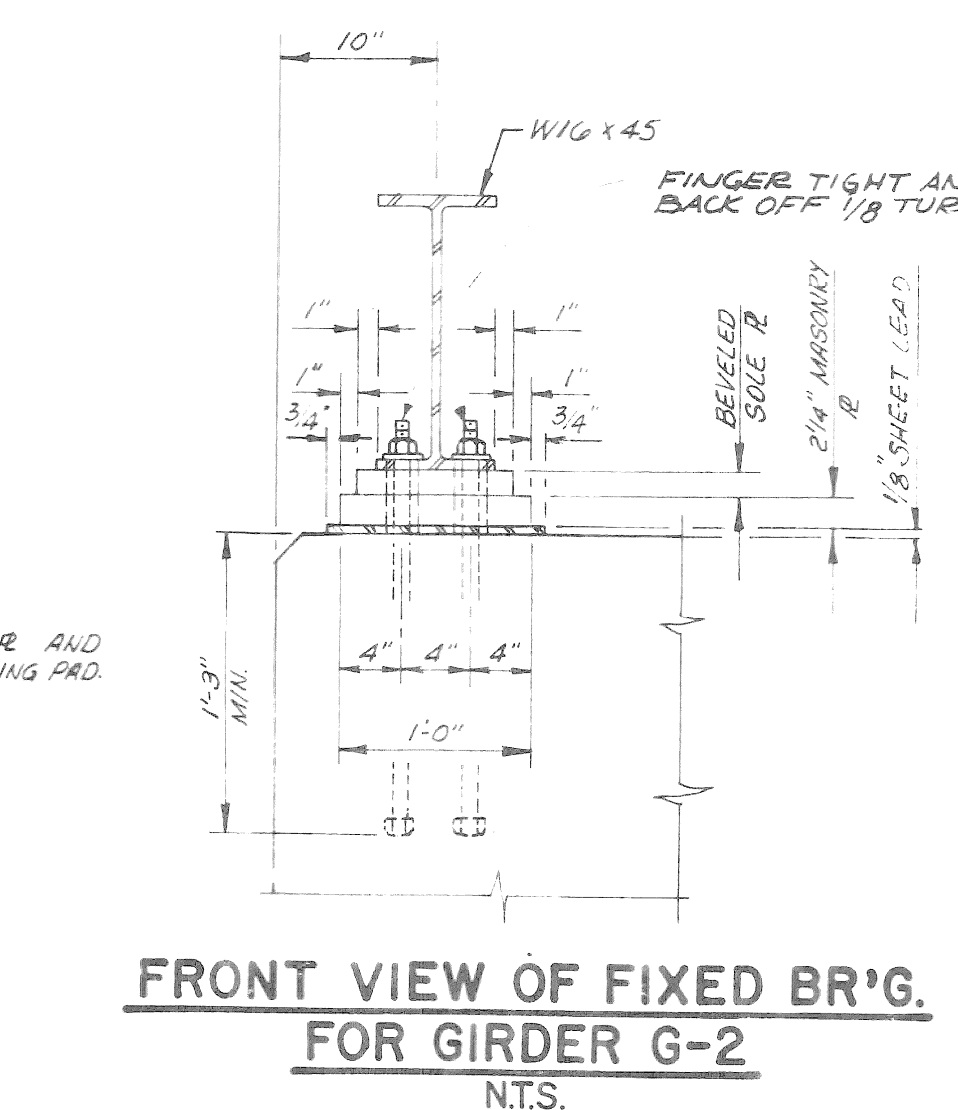
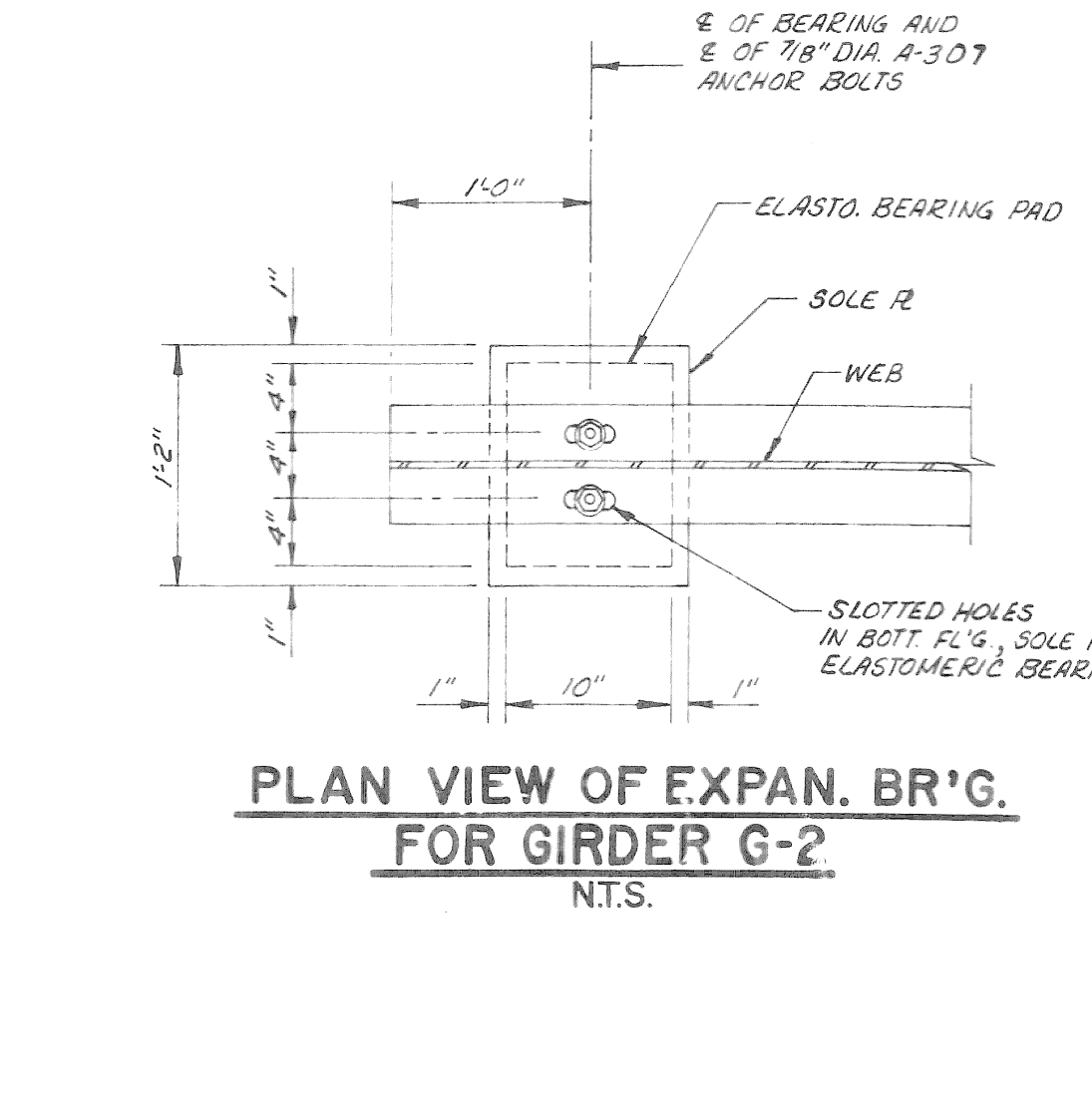
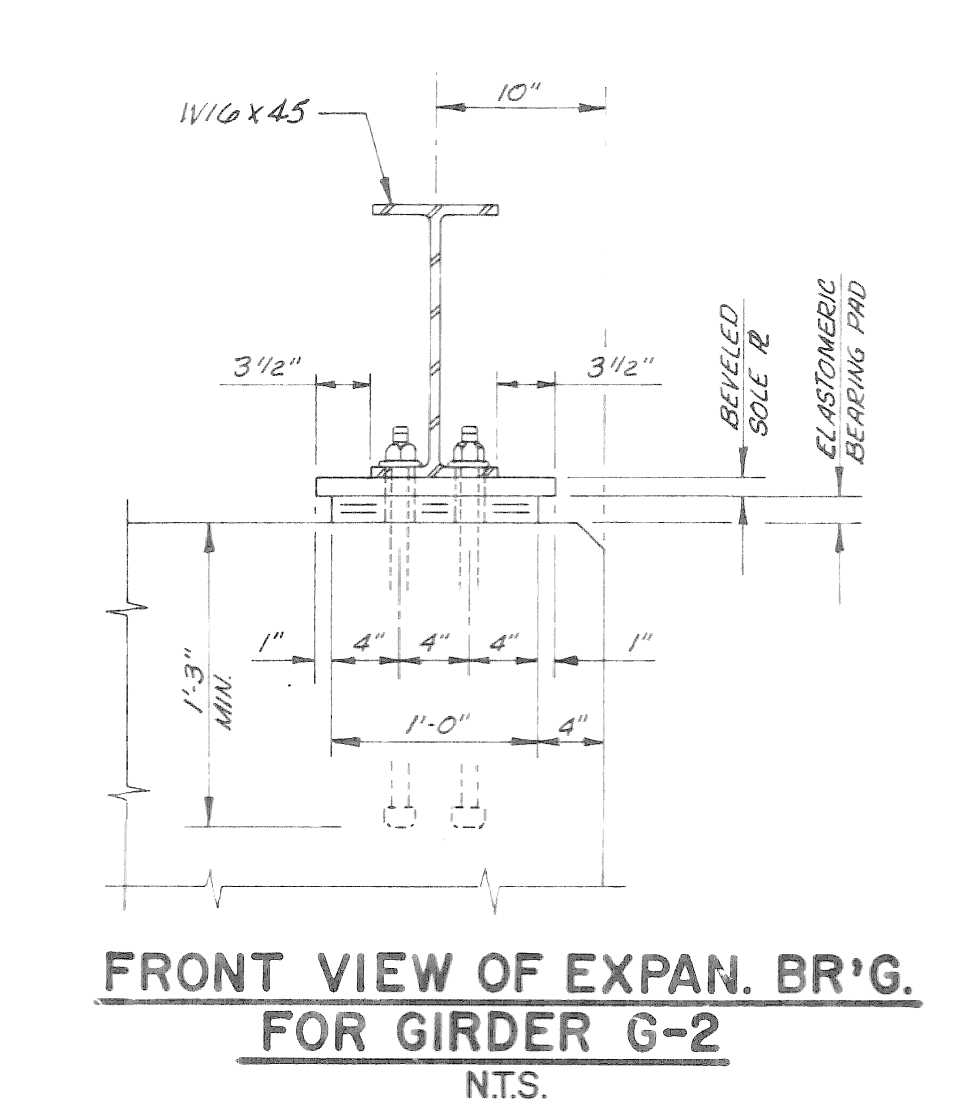
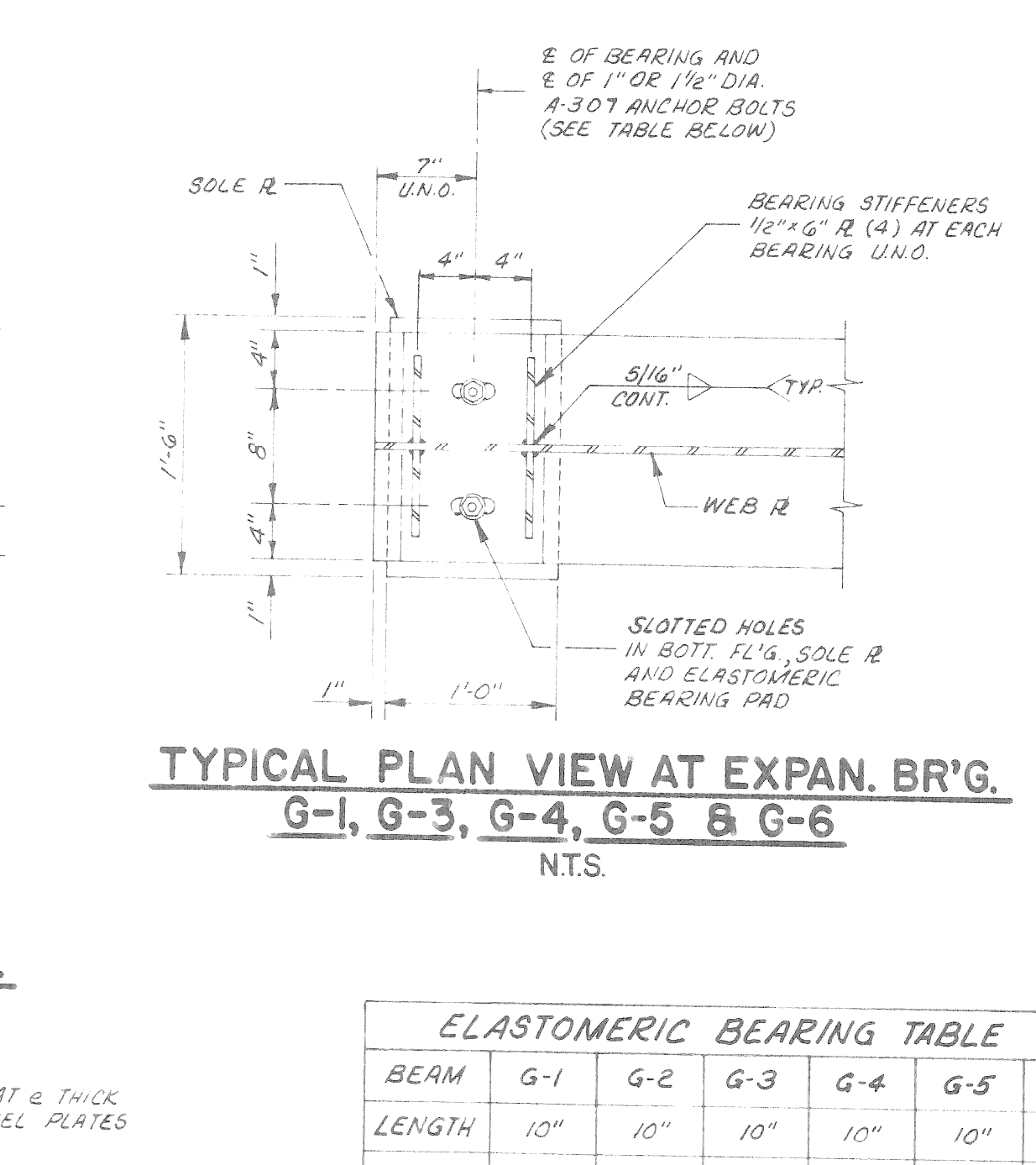
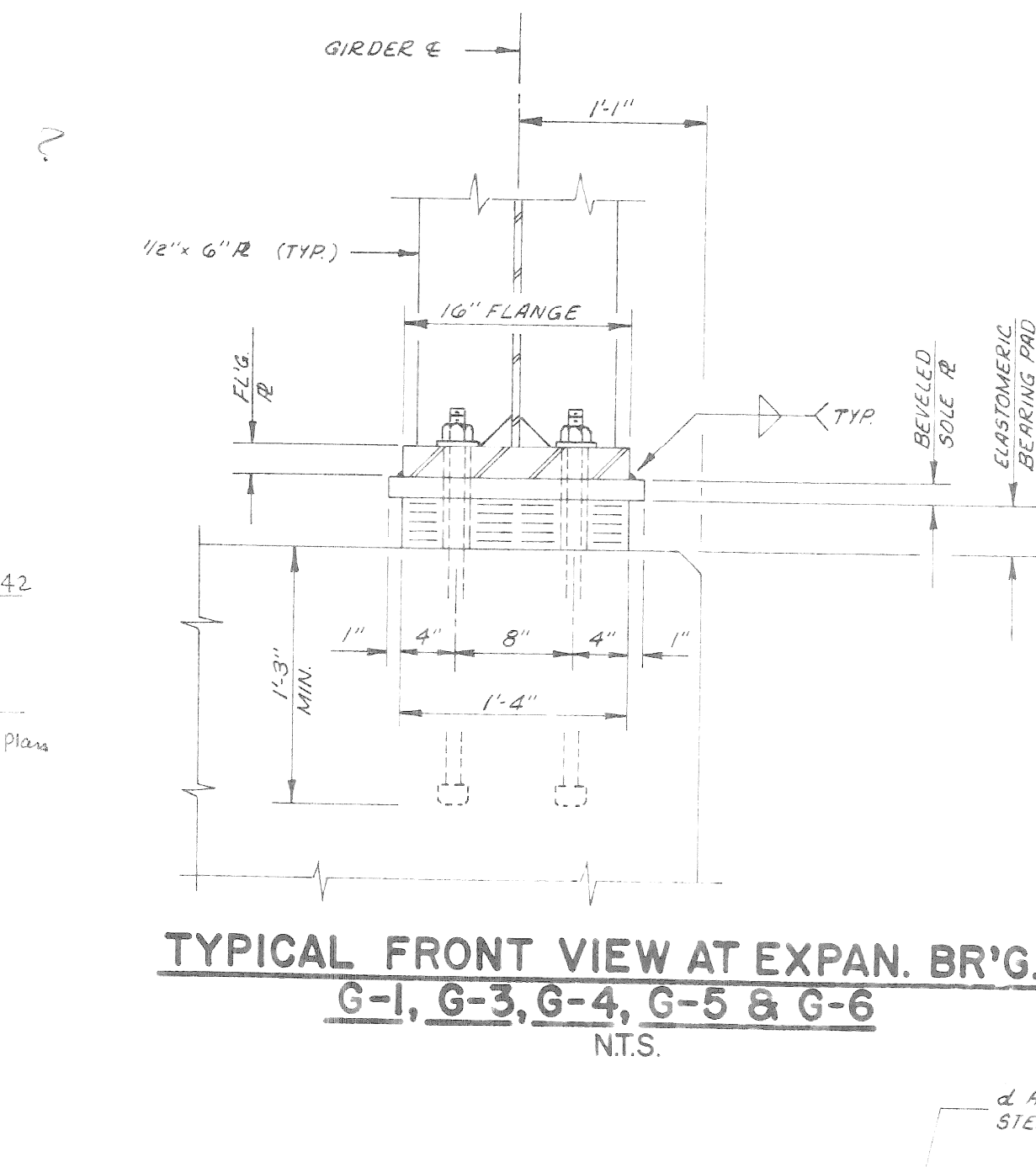
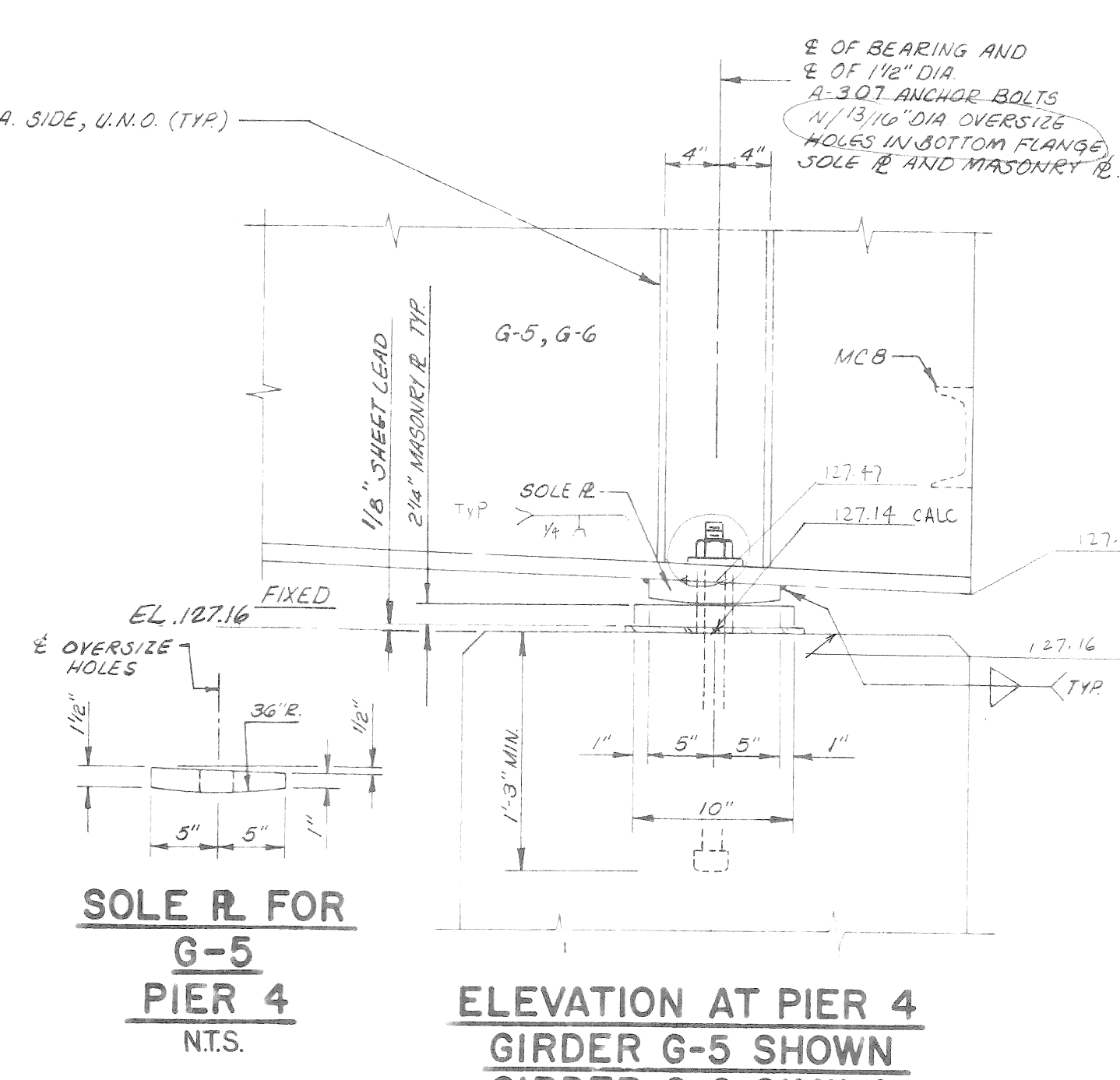
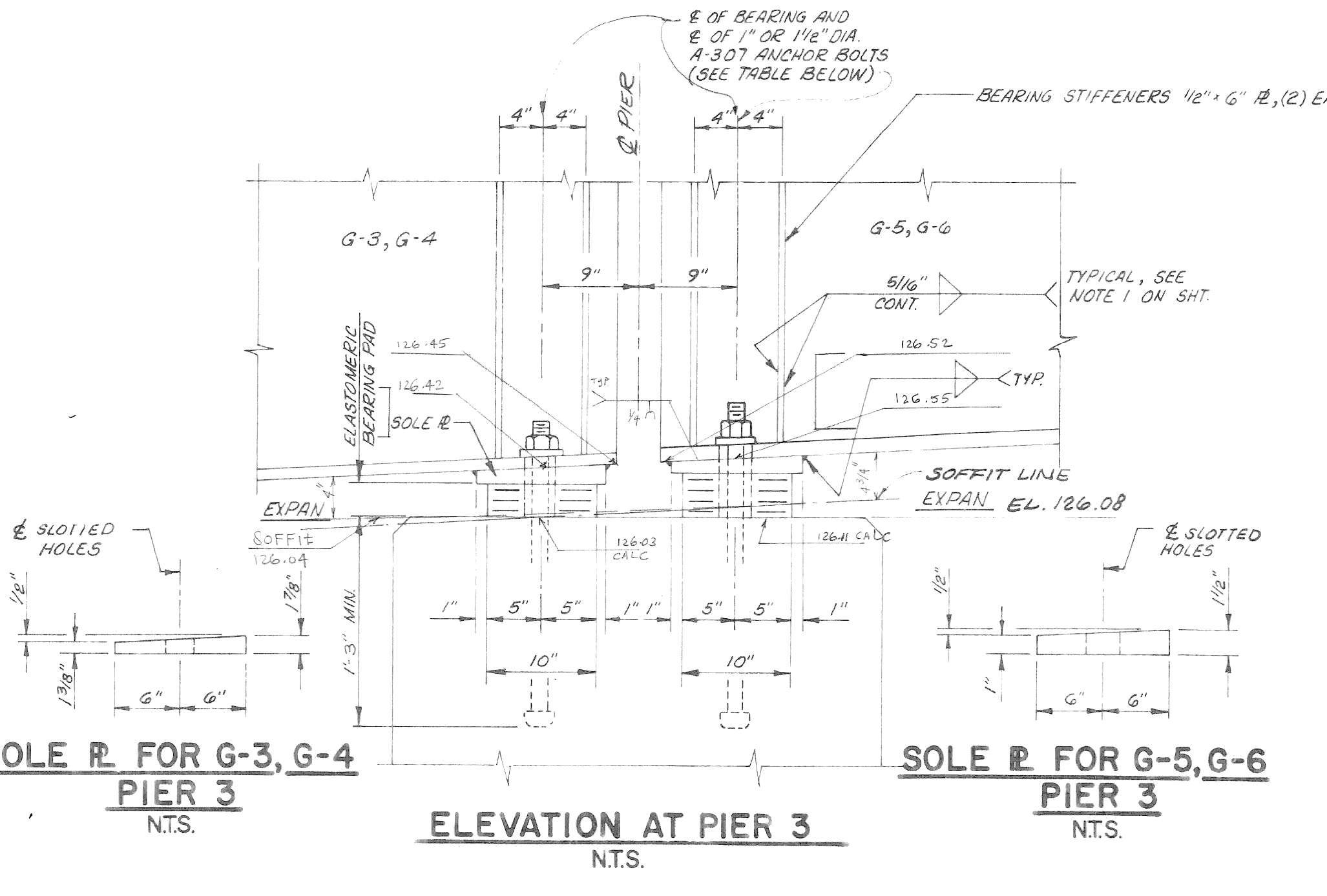
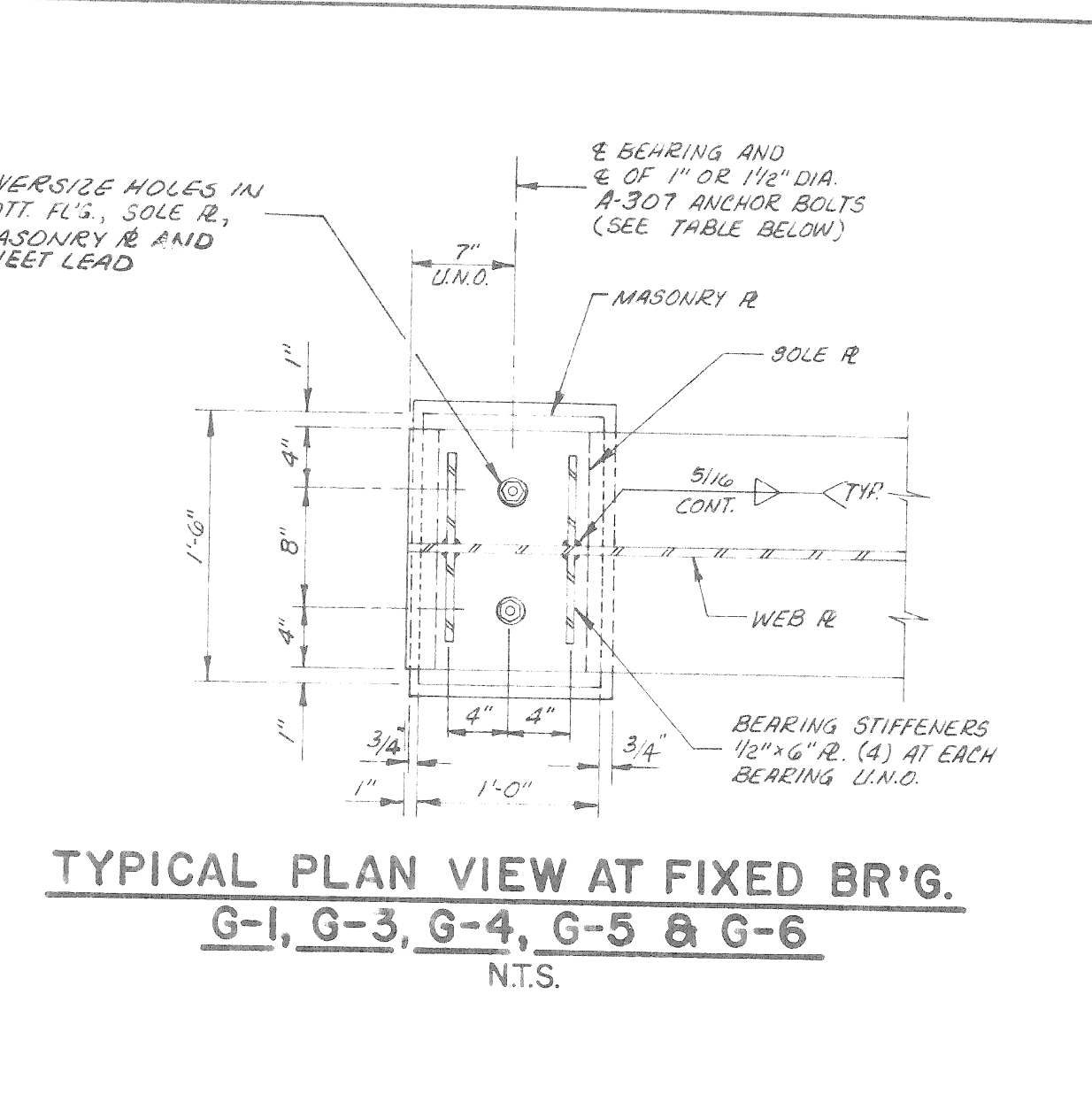
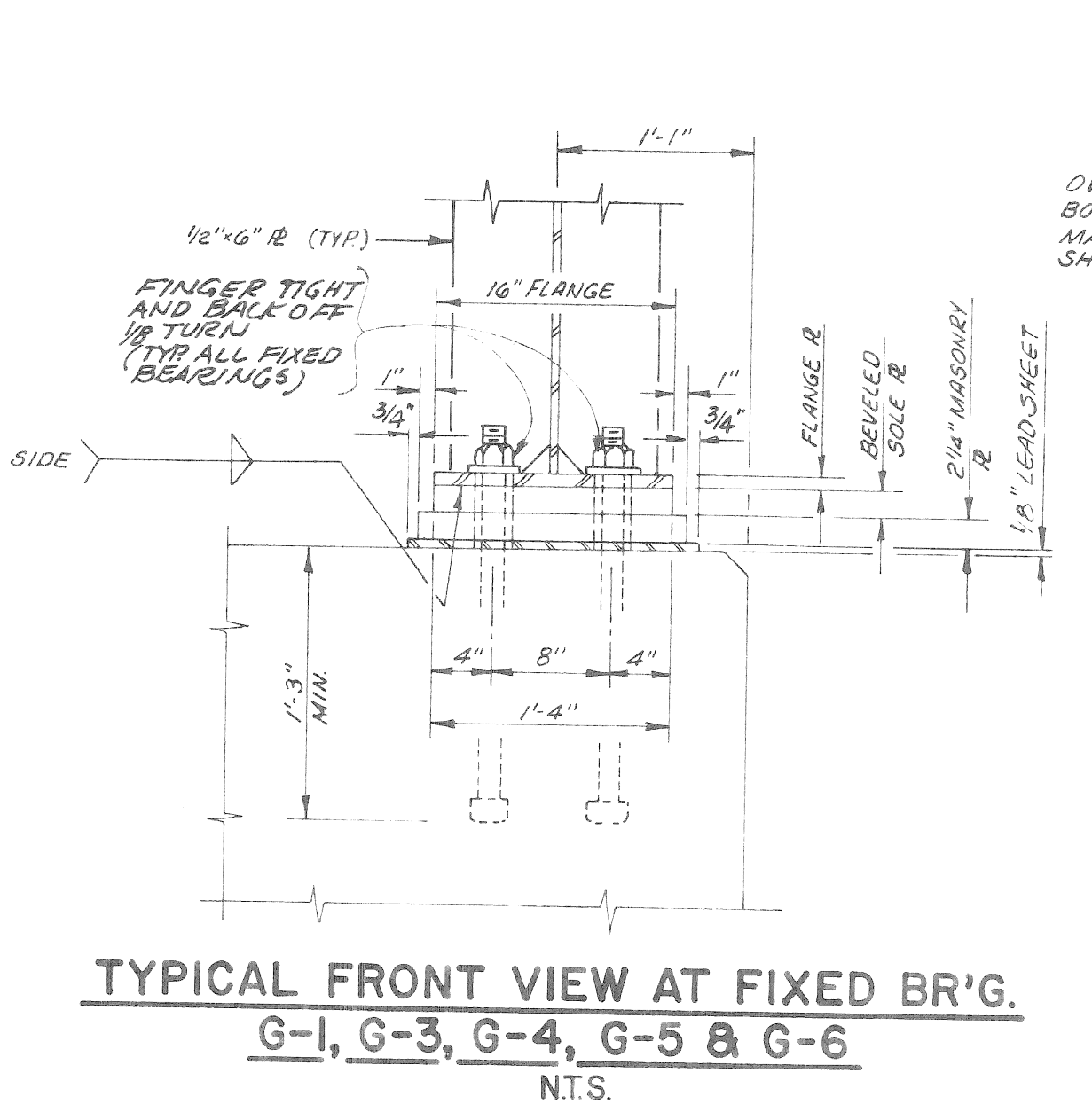
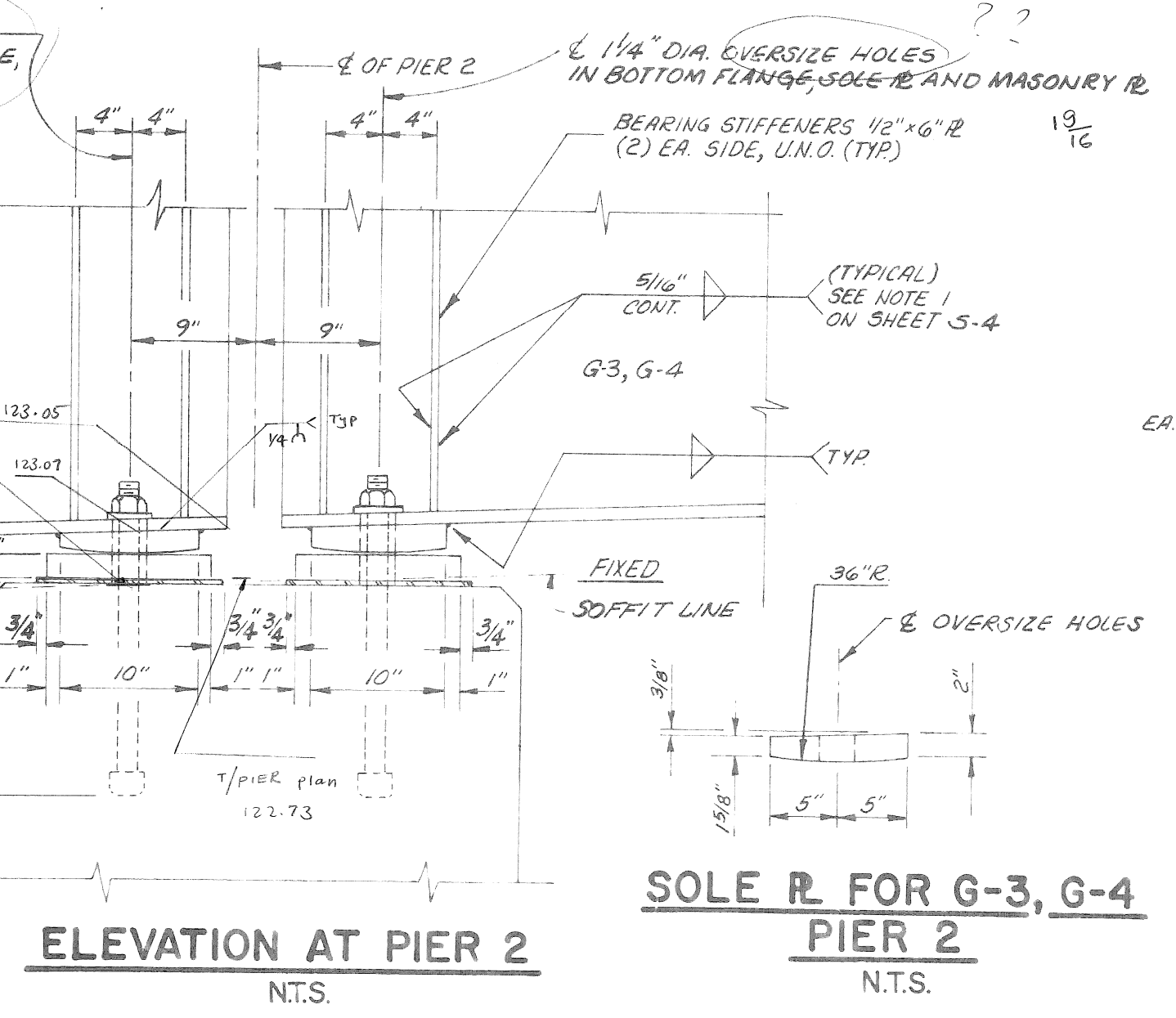
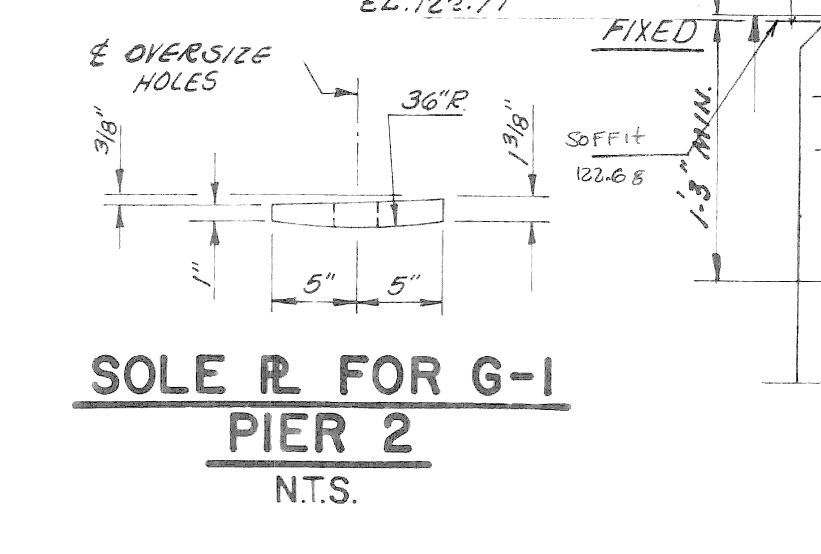
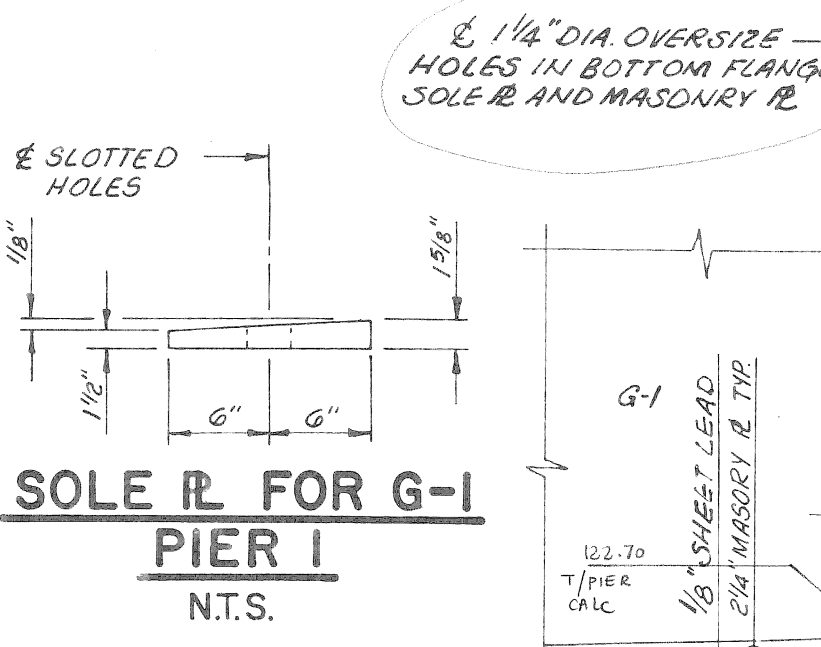
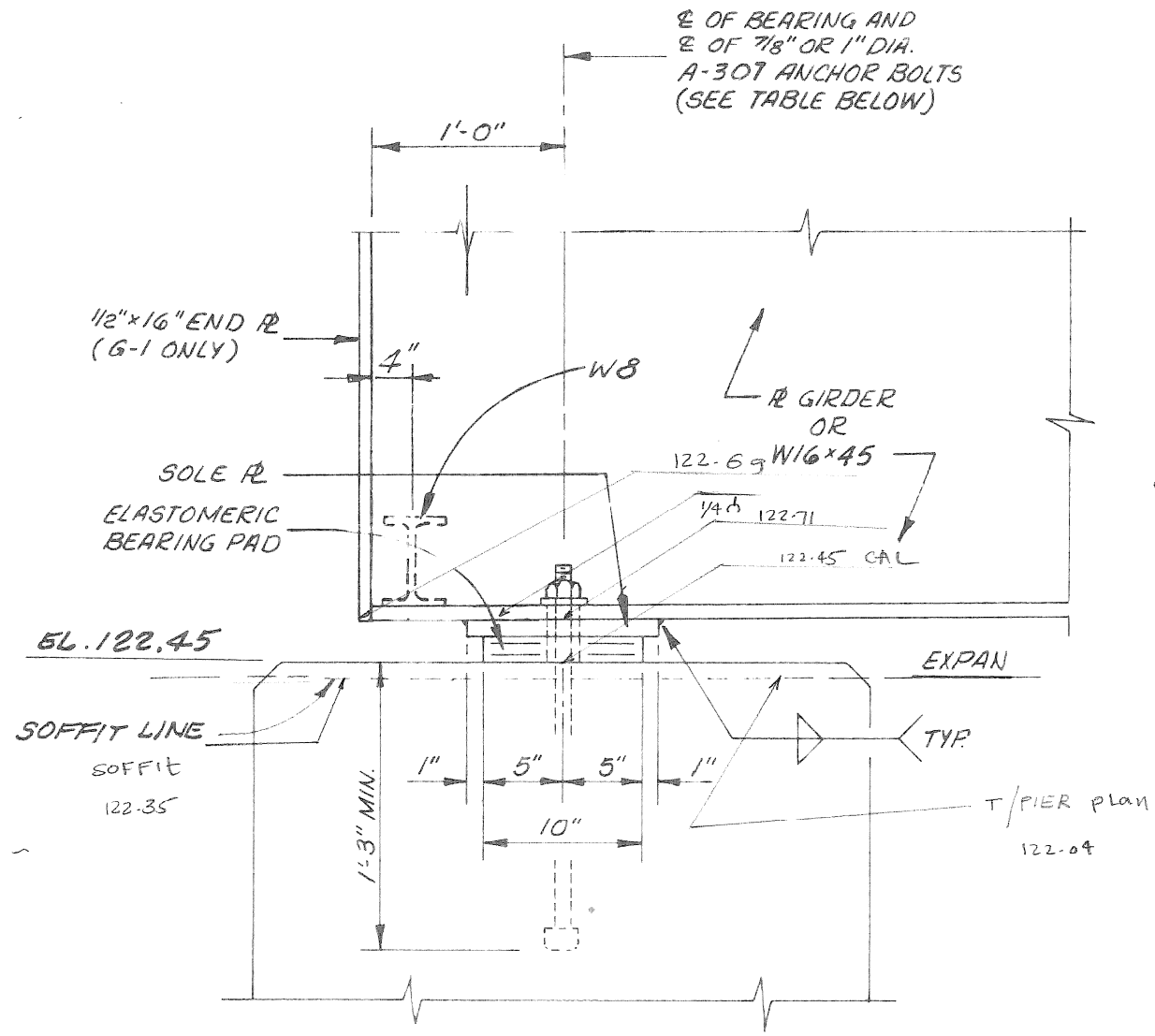

ELASTOMERIC BEARING TABLE						
BEAM	G-1	G-2	G-3	G-4	G-5	G-6
LENGTH	10"	10"	10"	10"	10"	10"
WIDTH	1'-4"	1'-0"	1'-4"	1'-4"	1'-4"	1'-4"
a	1 1/2"	1 1/2"	3"	3"	4"	4"
b	1	2	4	4	6	6
c	3/8"	1/4"	3/8"	3/8"	3/8"	3/8"
d	2	3	5	5	7	7
e	3/32"	3/32"	3/16"	3/32"	3/32"	3/32"
f	1/2"	3/8"	1/2"	1/2"	1/2"	1/2"

NOTE: ALL STEEL SOLE R'S SHALL BE BEVELED. SEE INDIVIDUAL SOLE R'T. DETAILS ON THIS SHEET.

ASTM A-307 ANCHOR BOLT TABLE						
BEAM	G-1	G-2	G-3	G-4	G-5	G-6
DIA. SIZE	1"	7/8"	1"	1"	1 1/2"	1 1/2"
LENGTH	1'-9"	1'-8 3/8"	1'-10 7/8"	1'-10 7/8"	2'-1 1/4"	2'-1 1/4"
PROJECTION	6"	5 3/8"	8"	8"	9 1/2"	9 1/2"
SLOT HOLES	1 1/16" x 1 1/2"	1 1/16" x 1 1/2"	1 1/16" x 2 1/2"	1 1/16" x 2 1/2"	1 1/2" x 3 1/2"	1 1/2" x 3 1/2"

- NOTES:**
- ELASTOMER FOR LAMINATED PADS SHALL BE 50 DUROMETER HARDNESS.
 - THE TOP OF PIERS SHALL BE GIVEN AN APPLICATION OF PROTECTIVE SEALANT COATING FOR CONCRETE AFTER THE ELASTOMERIC PADS HAVE BEEN PLACED IN THE FINAL POSITION ON THE STRUCTURE.
 - SLOTTED HOLES IN ALL BEARING MATERIALS SHALL BE CENTERED ON THE ANCHOR BOLTS.

REVISION
DATE
NOV 29 1989
CITY OF DETROIT
CITY ENGINEERING DEPARTMENT
CITY BRIDGE No. BP-27

Project
MADISON INTERNATIONAL OF MICHIGAN
Engineers, Architects, Planners
1420 Washington Blvd
Detroit, Michigan 48226

Sheet Title
RANDOLPH STREET PEDESTRIAN BRIDGE BEARING DETAILS

DESIGN BY
KCH/JSO
DRAWN BY
K.C.H./L.S.
CHECKED BY
P.A.
DATE
NOVEMBER, 89
PROJECT NO.
3012
SHEET NO.
S-10

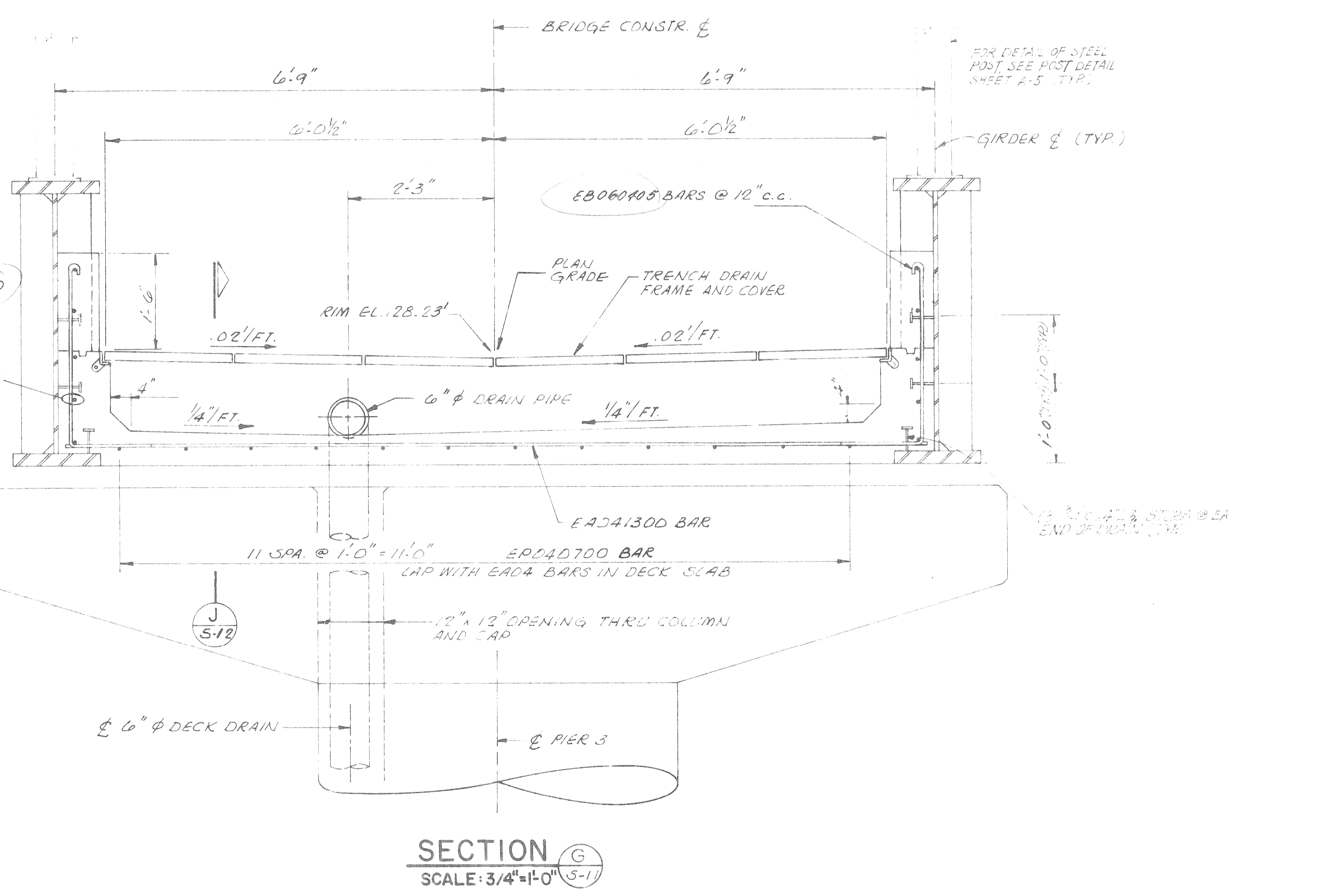
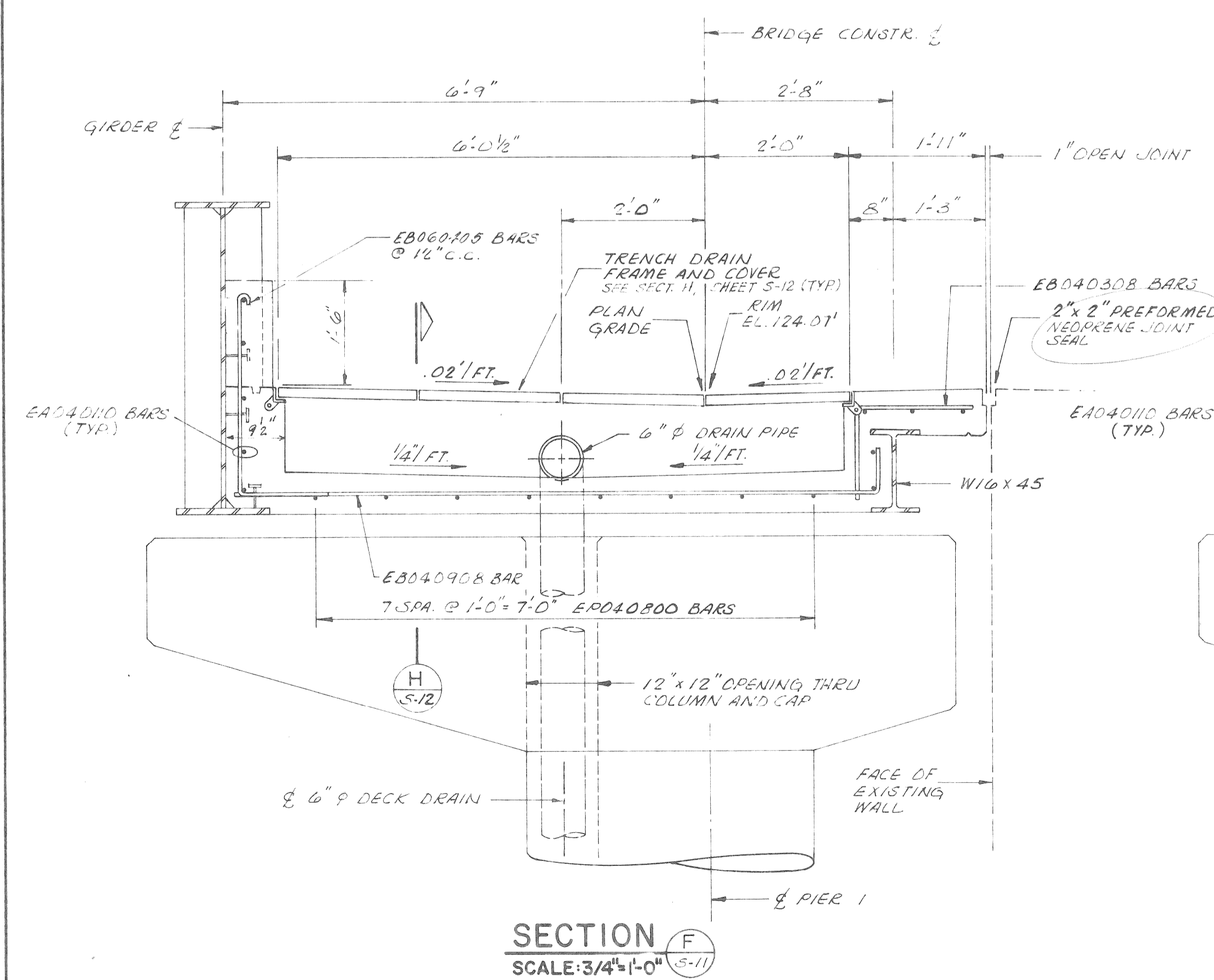
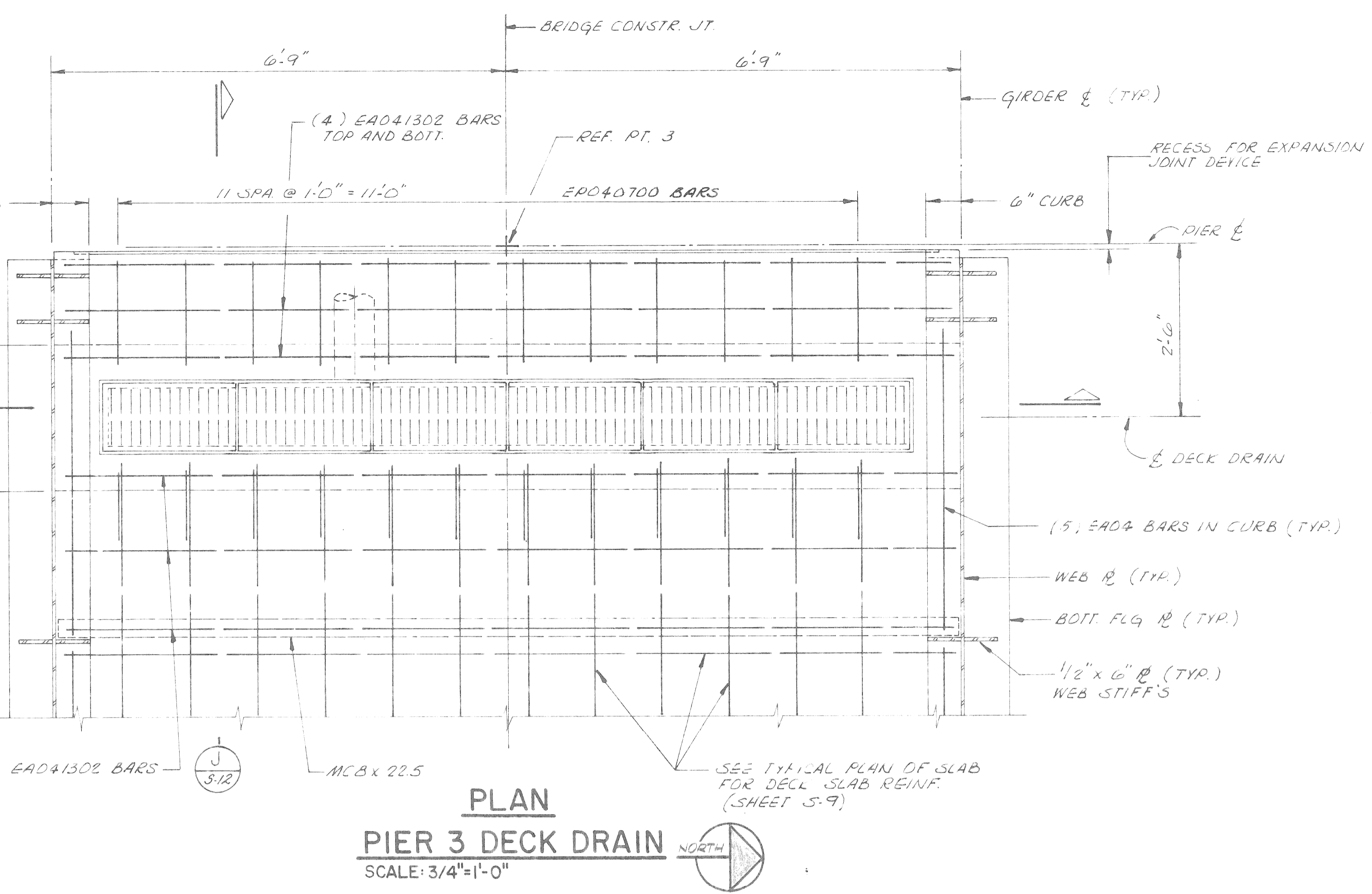
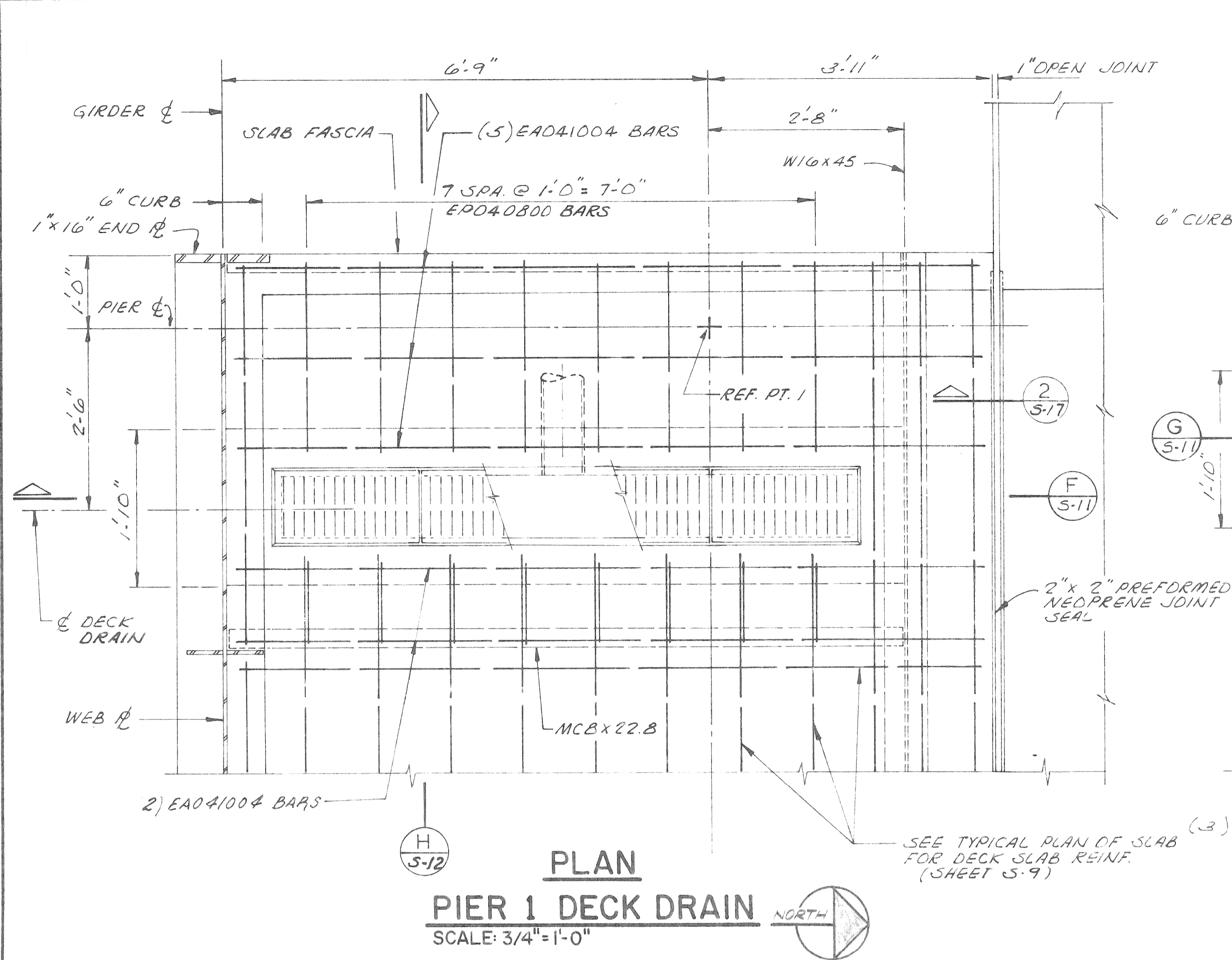

REVISION	
DATE	
NOV. 89	

CITY OF DETROIT
 CITY ENGINEERING DEPARTMENT
 CITY BRIDGE No. BP-27

Project: RANDOLPH STREET PEDESTRIAN BRIDGE
 Sheet Title: DECK DRAIN DETAILS

MADISON INTERNATIONAL OF MICHIGAN
 Engineers, Architects, Planners
 1420 Washington Blvd.
 Detroit, Michigan 48226

DESIGN BY: KCH/50
 DRAWN BY: C.V.B.
 CHECKED BY: P.A.

DATE: NOVEMBER, 89
 PROJECT NO.: 8612
 SHEET NO.: S-11

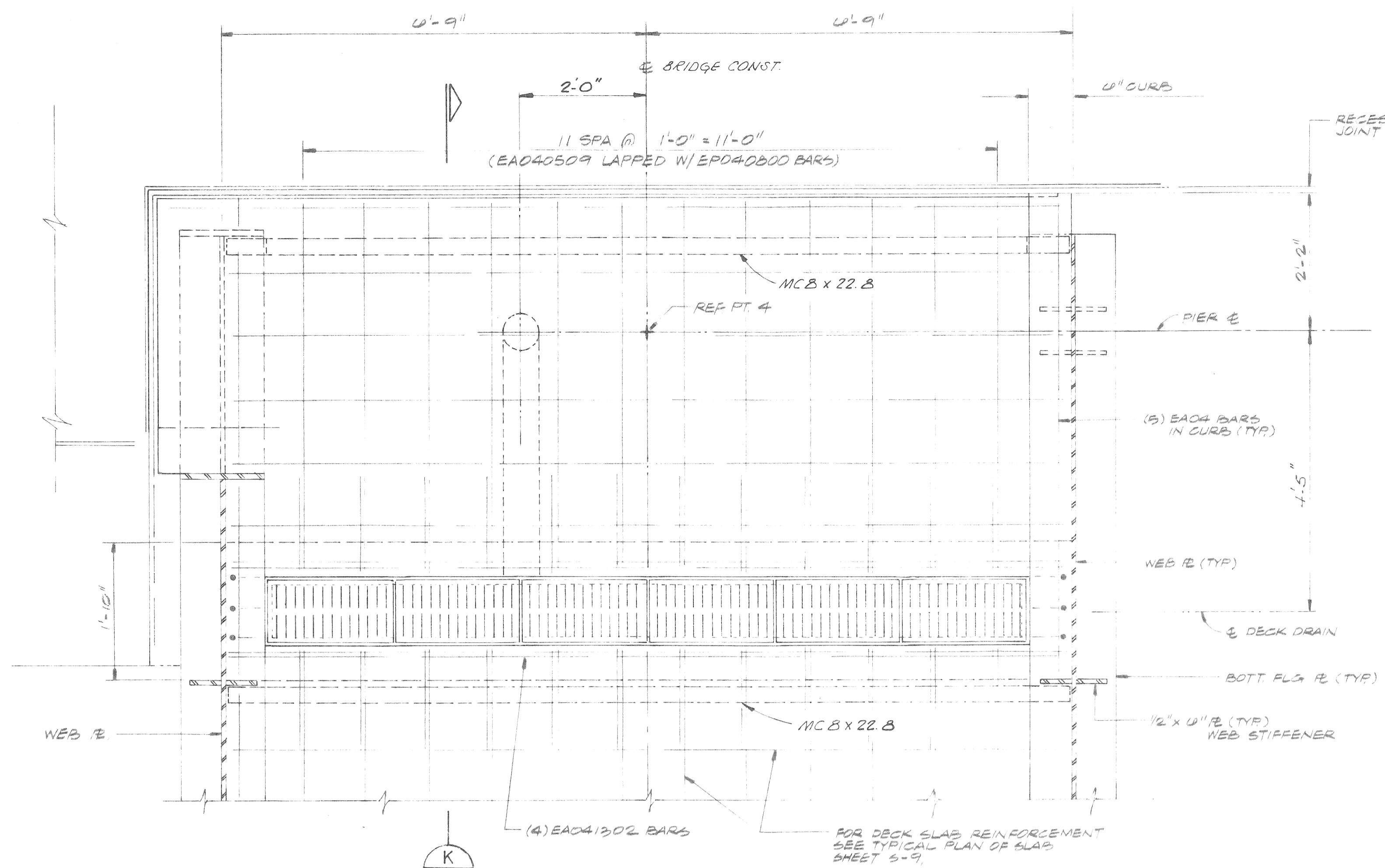

PLAN
PIER 4 DECK DRAIN
SCALE: 3/4"=1'-0"

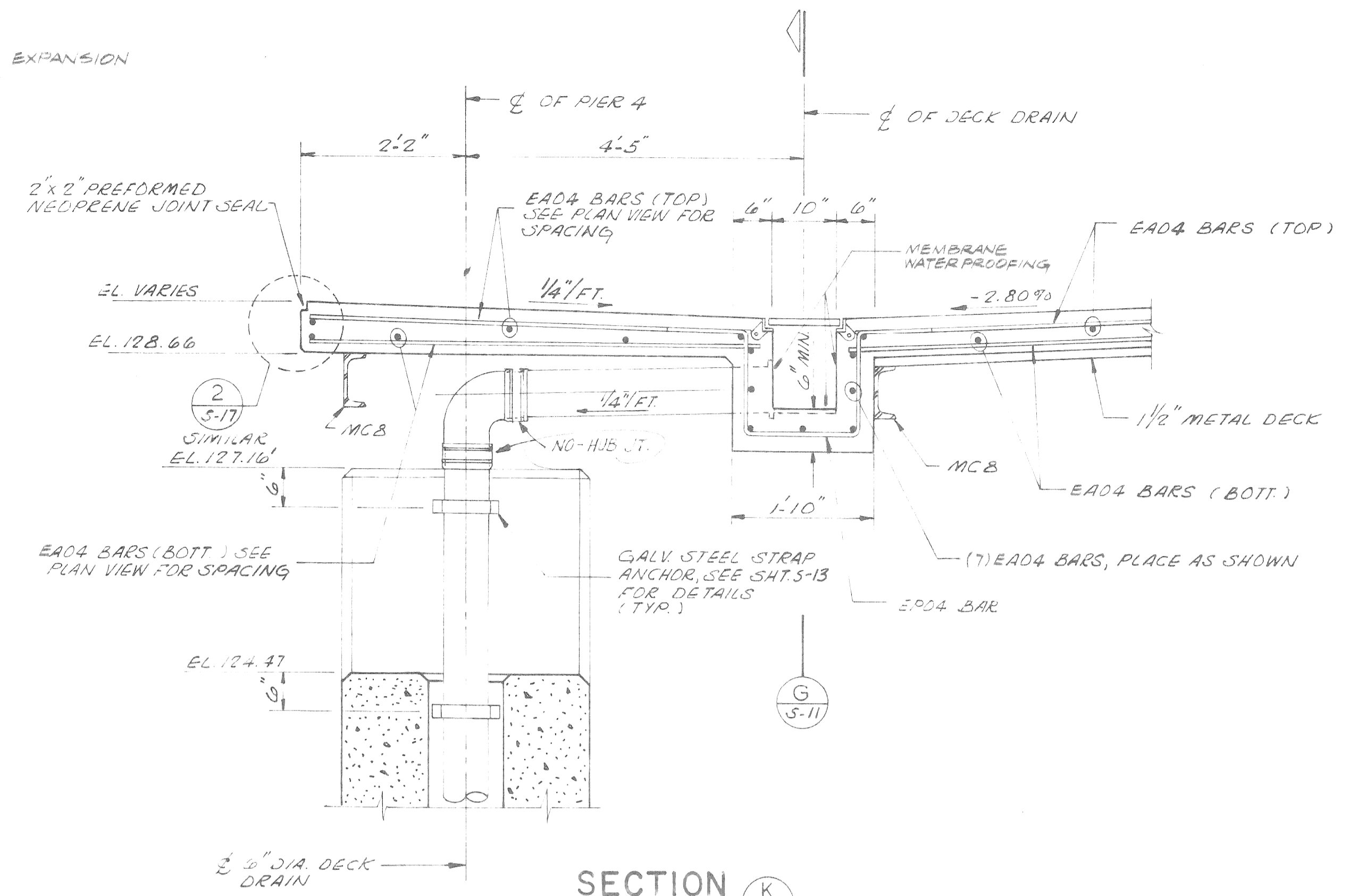

SECTION K
SCALE: 3/4"=1'-0"

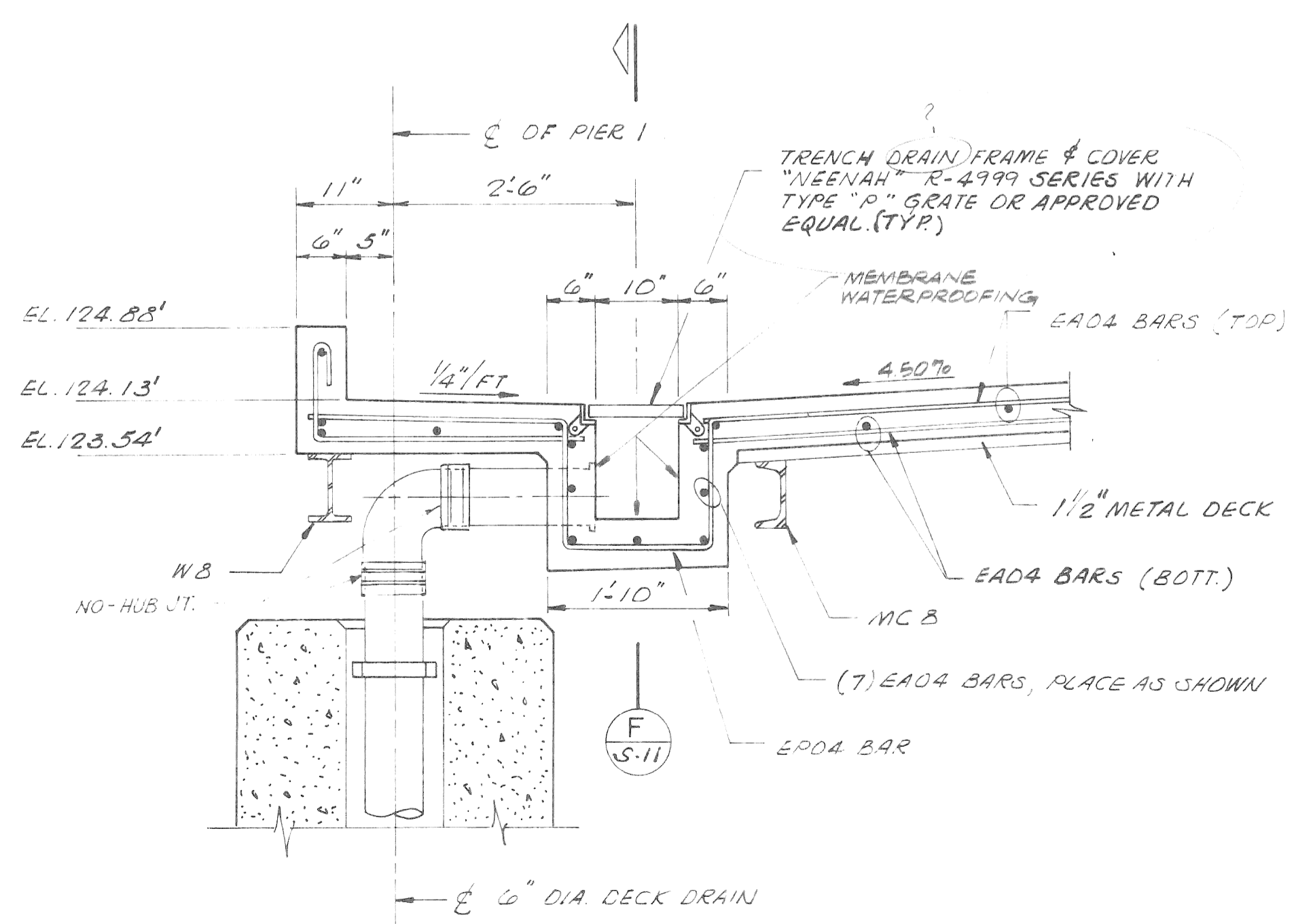

SECTION H
SCALE: 3/4"=1'-0"

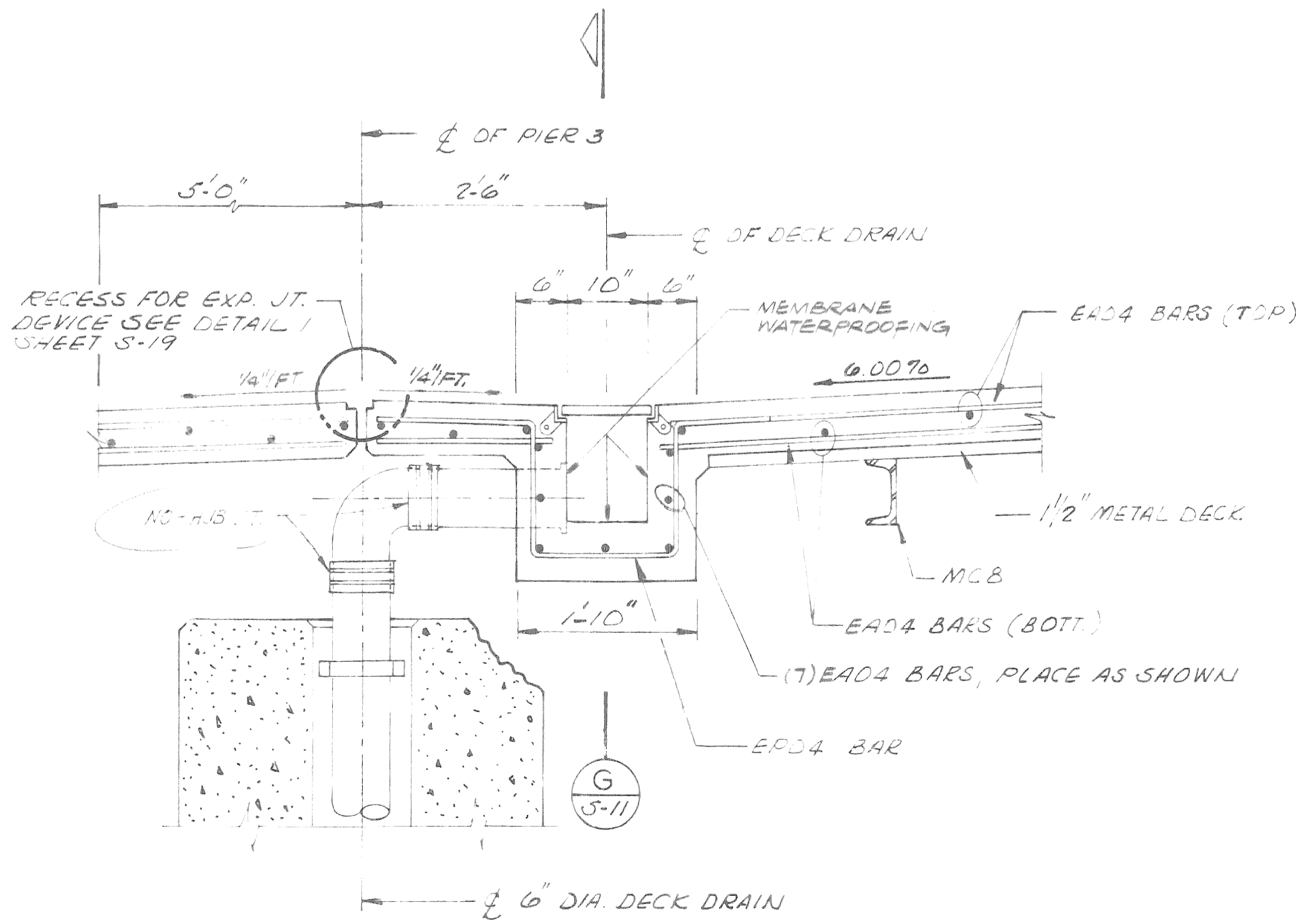

SECTION J
SCALE: 3/4"=1'-0"

REVISION
LOCAL FILE WITH CITY OF DETROIT ENGINEERING DEPARTMENT
DATE: NOV. 89
DRAWN BY: C.J.B.
CHECKED BY: P.A.

CITY OF DETROIT
CITY ENGINEERING DEPARTMENT
CITY BRIDGE No. BP-27

Project: **RANDOLPH STREET PEDESTRIAN BRIDGE**
Sheet Title: **STRUCTURAL STEEL DETAILS**

MADISON INTERNATIONAL OF MICHIGAN
Engineers, Architects, Planners
1420 Washington Blvd.
Detroit, Michigan 48226

DESIGN BY: K.C.H./S.O.
DRAWN BY: C.J.B.
CHECKED BY: P.A.
DATE: NOVEMBER, 89
PROJECT NO.: 8612
SHEET NO.: S-12

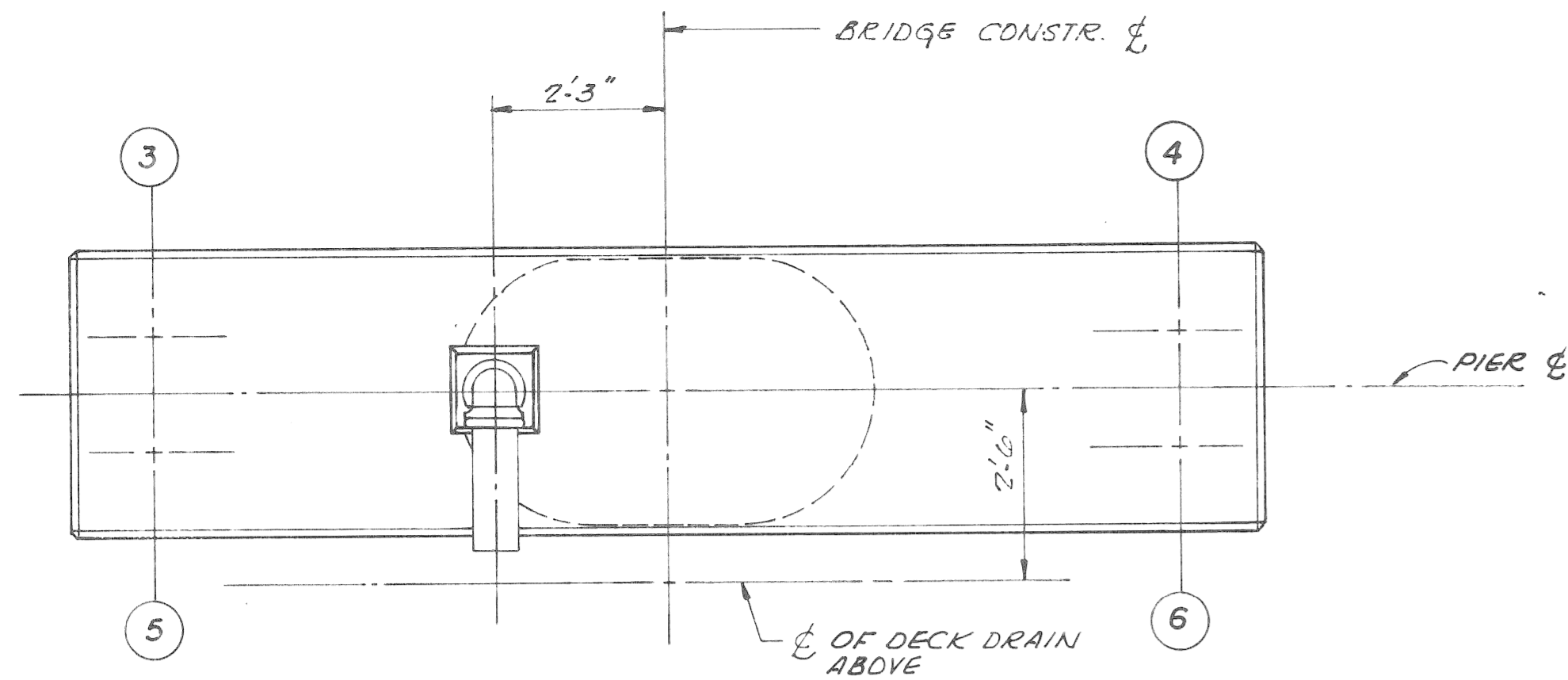

PLAN ABOVE PIER CAP
SCALE: 1/2" = 1'-0"

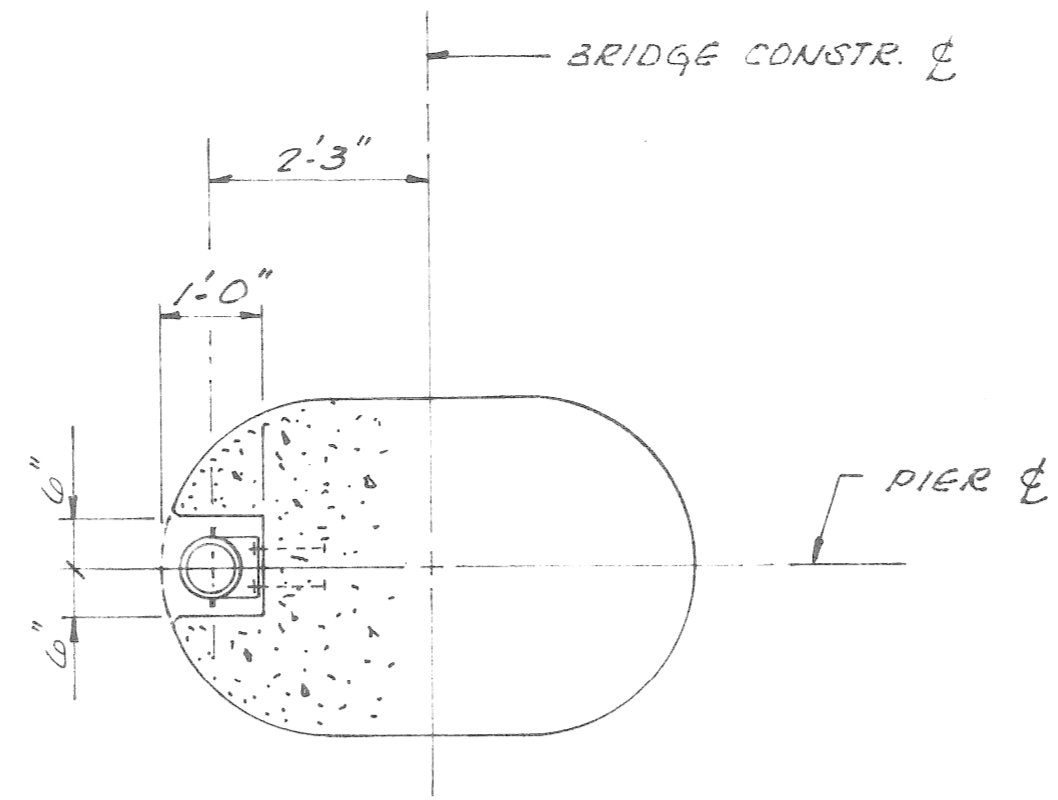

PLAN SECTION THRU COLUMN
SCALE: 1/2" = 1'-0"

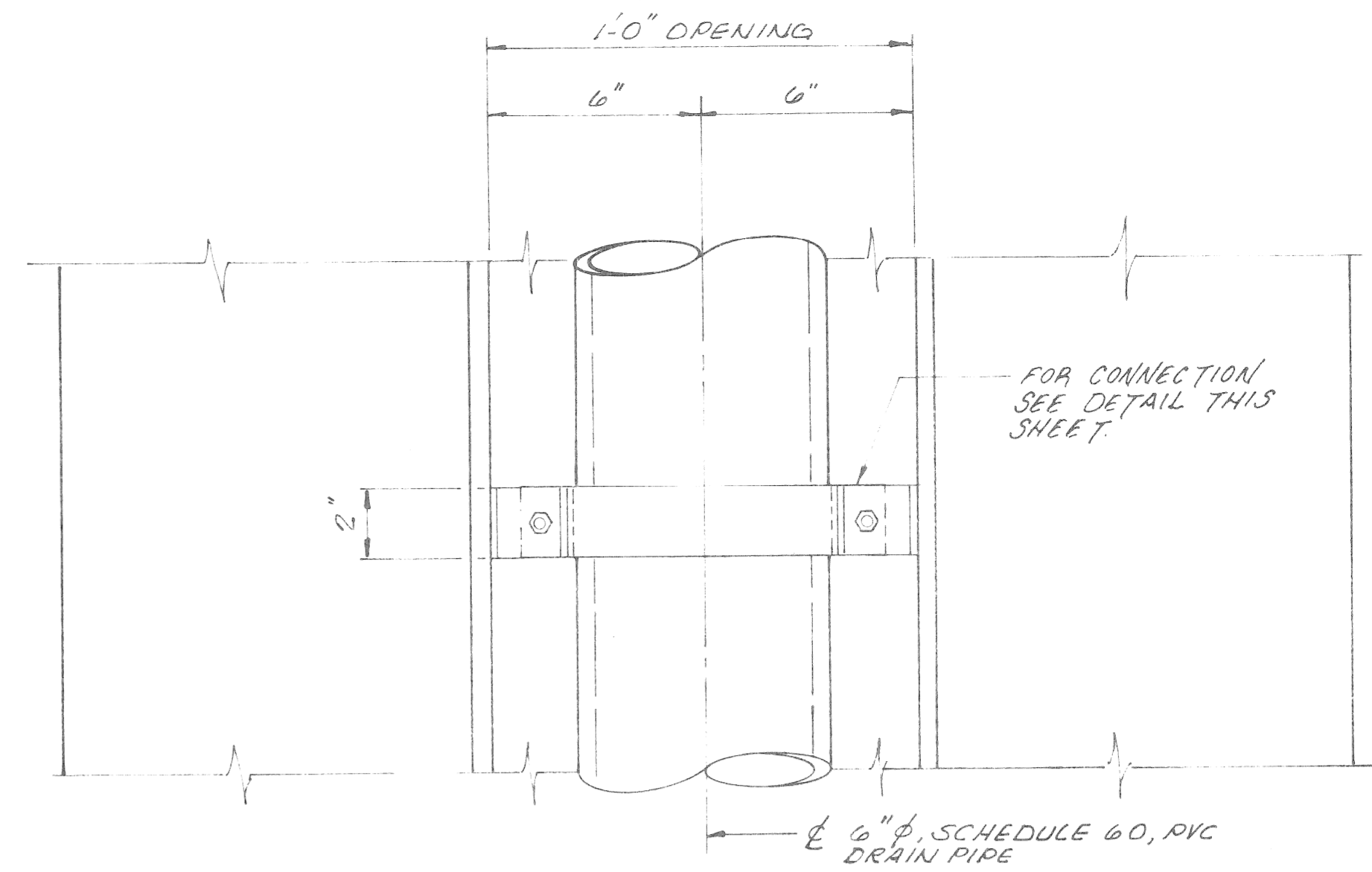

DETAIL 1
SCALE: 3" = 1'-0" (S-13)

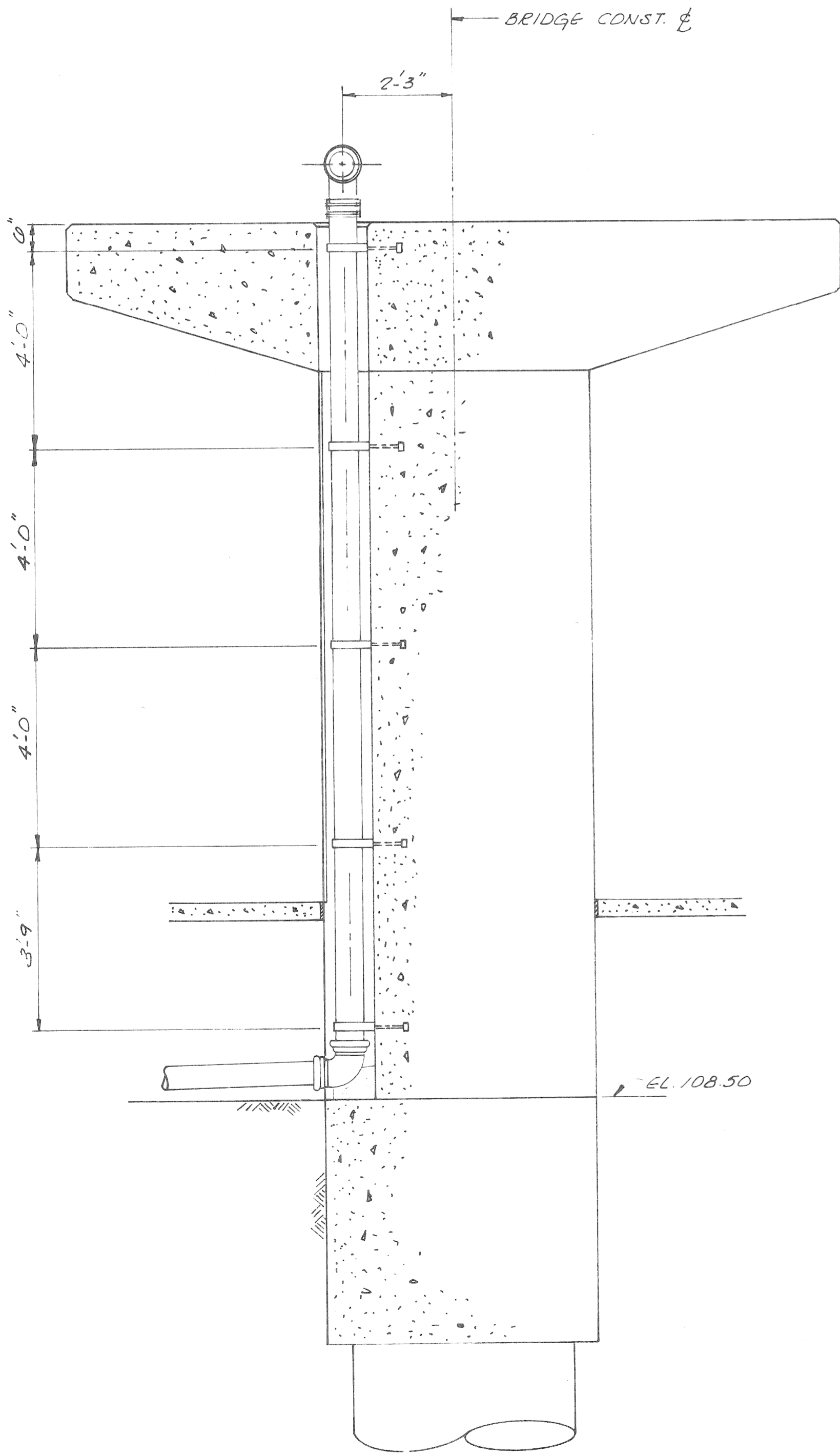

ELEVATION THRU COLUMN & CAP
SCALE: 1/2" = 1'-0"

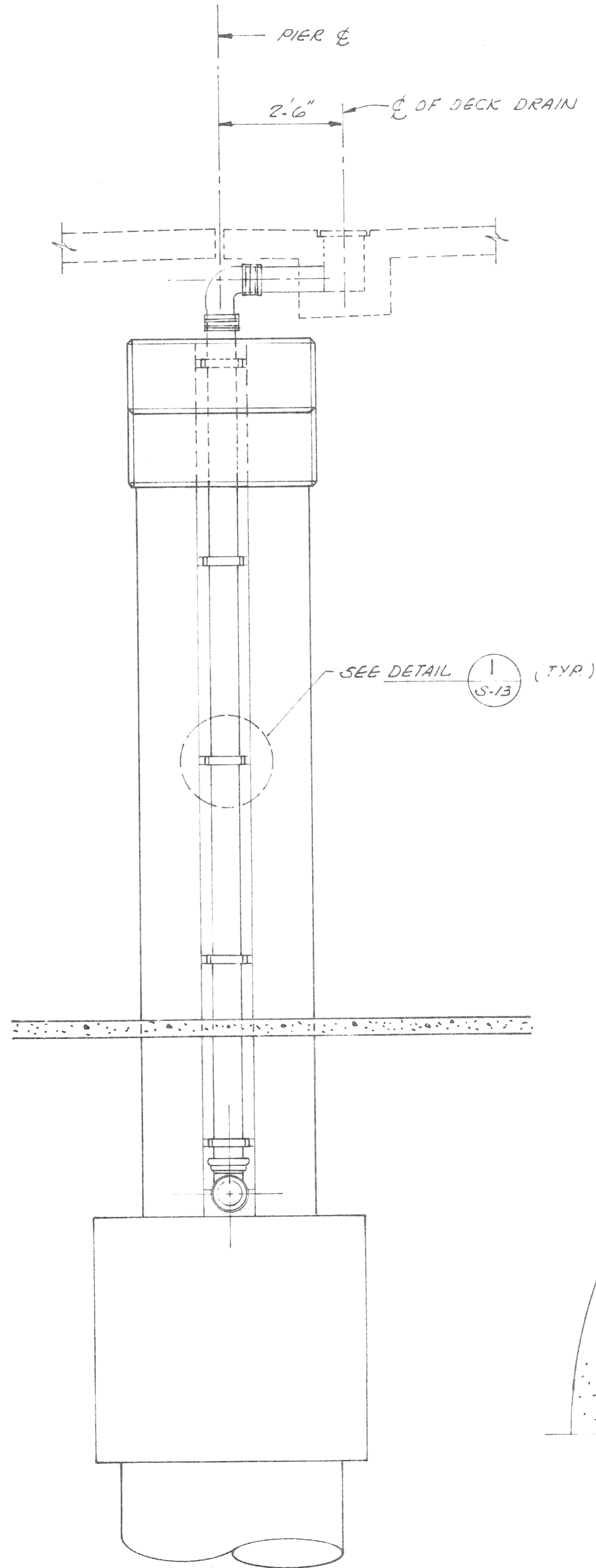

END ELEVATION
SCALE: 1/2" = 1'-0"

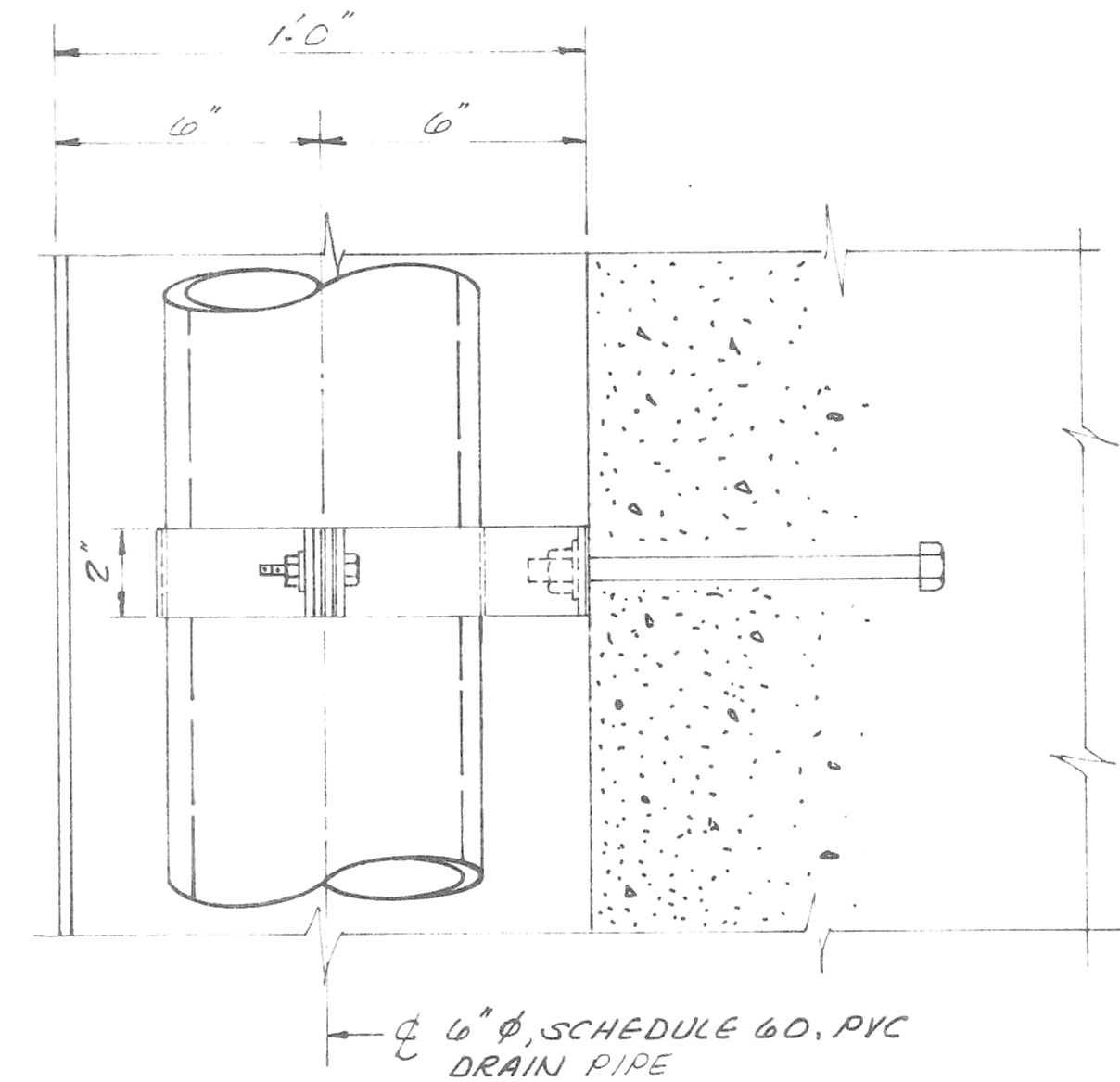

SECTION A
SCALE: 3" = 1'-0" (S-13)

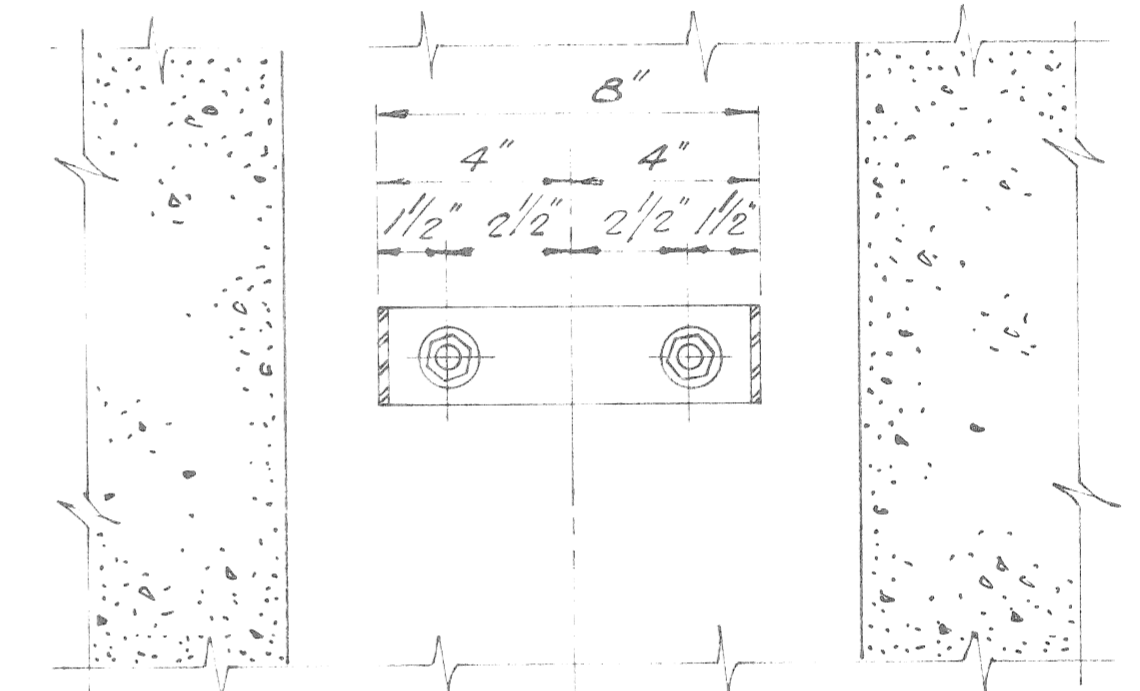

SECTION B
SCALE: 3" = 1'-0" (S-13)

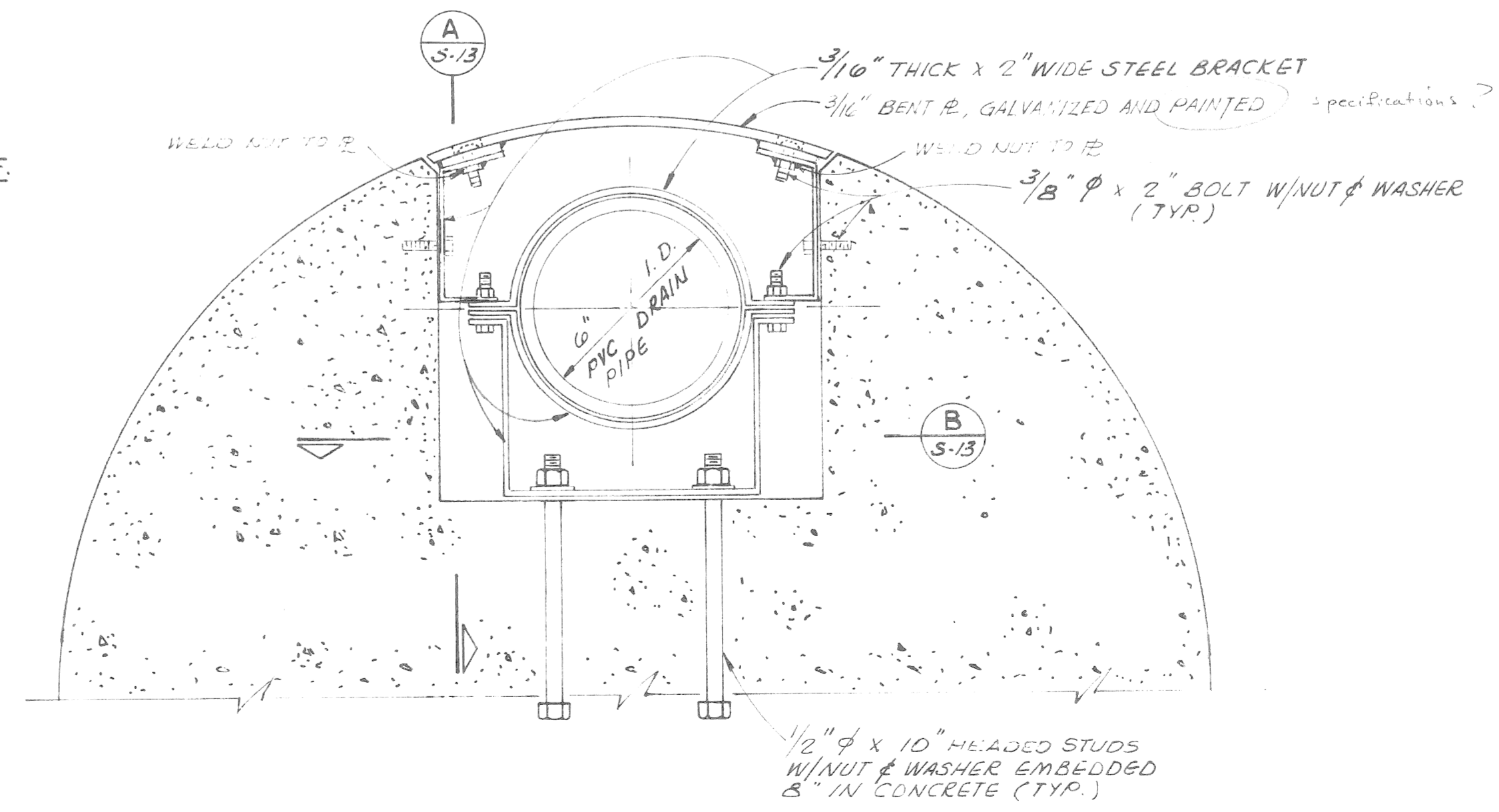

DRAIN PIPE CONNECTION DETAIL
SCALE: 3" = 1'-0"

REVISION	
DATE	
NO.	
BY	
CHKD.	
APP.	

CITY OF DETROIT
CITY ENGINEERING DEPARTMENT
CITY BRIDGE No. BP-27

Project: RANDOLPH STREET PEDESTRIAN BRIDGE
Sheet Title: DECK DRAIN DETAILS

MADISON INTERNATIONAL OF MICHIGAN
Engineers, Architects, Planners
1420 Washington Blvd.
Detroit, Michigan 48226

DESIGN BY: K.C.H./S.O.
DRAWN BY: C.U.B.
CHECKED BY: P.A.

DATE: NOVEMBER, 1971
PROJECT No.: 8612
SHEET No.: S-13

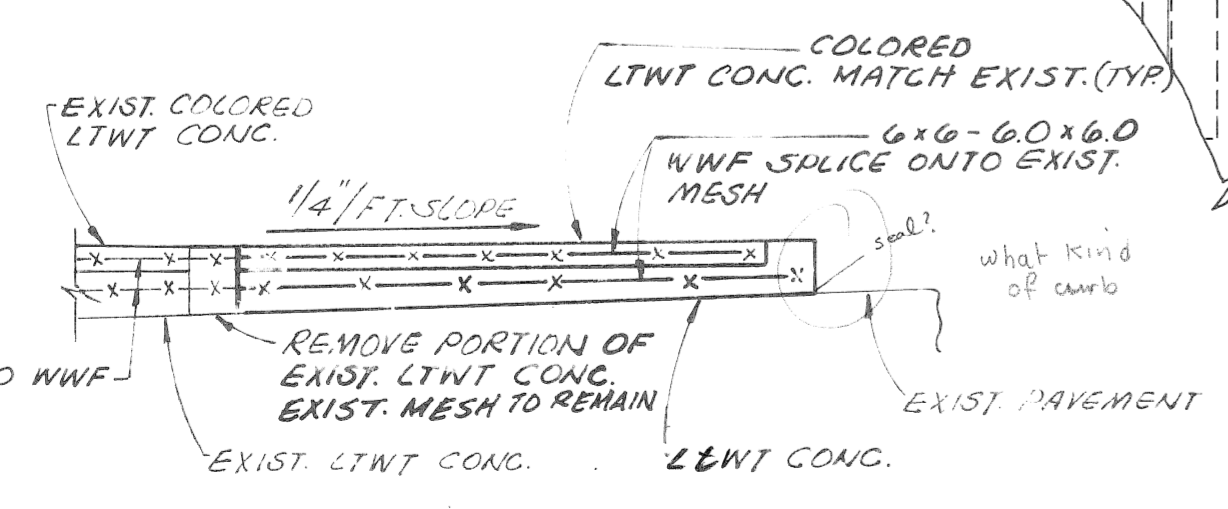
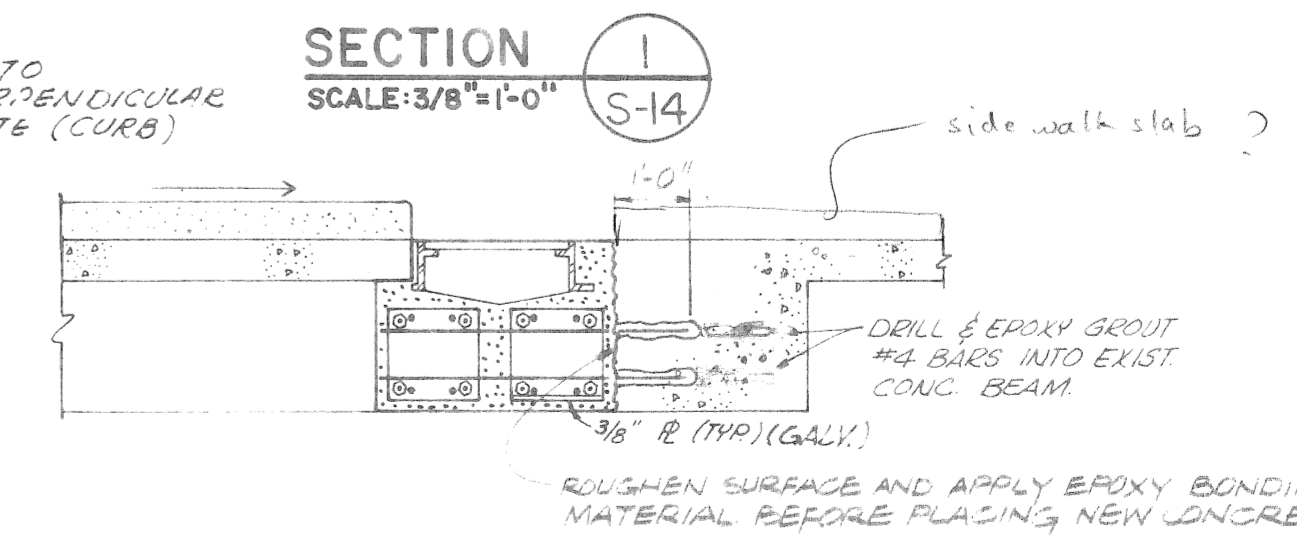
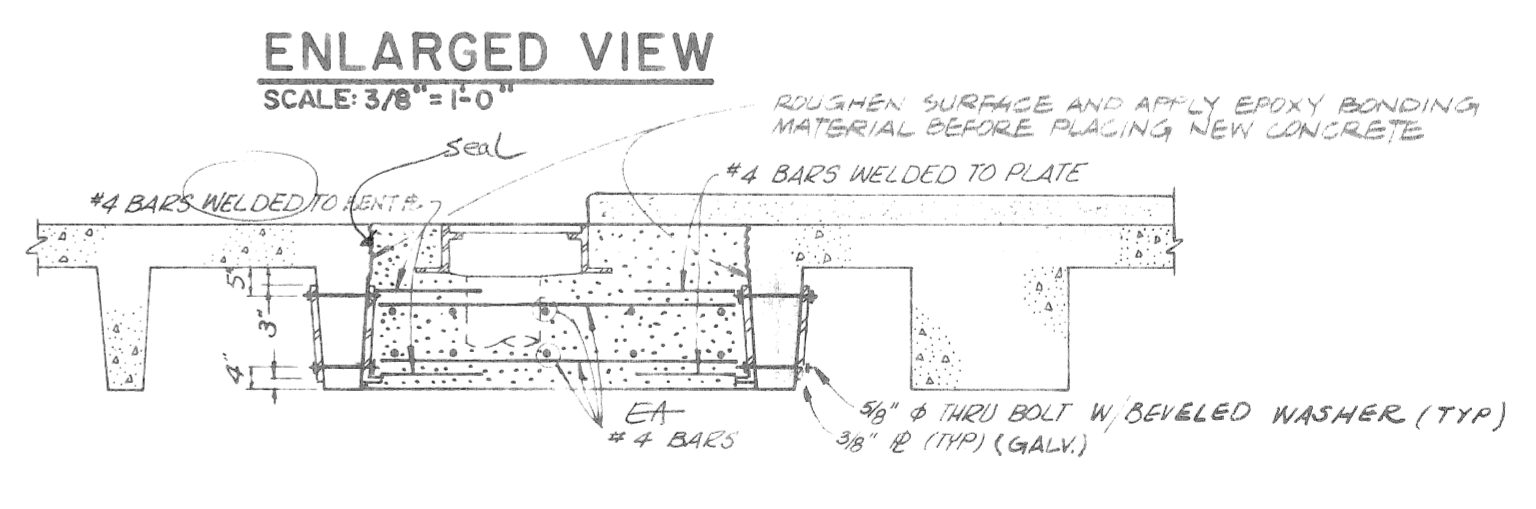
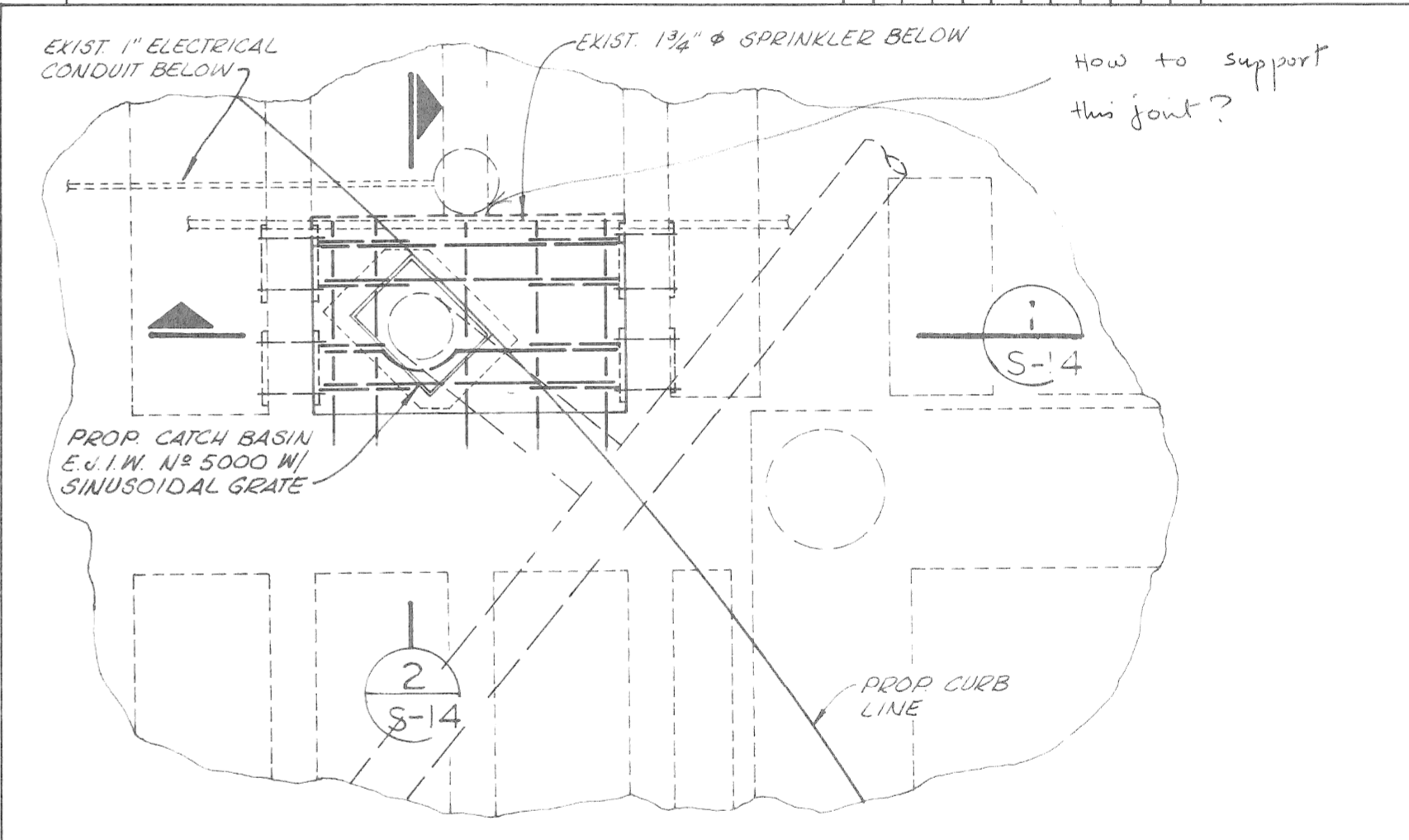
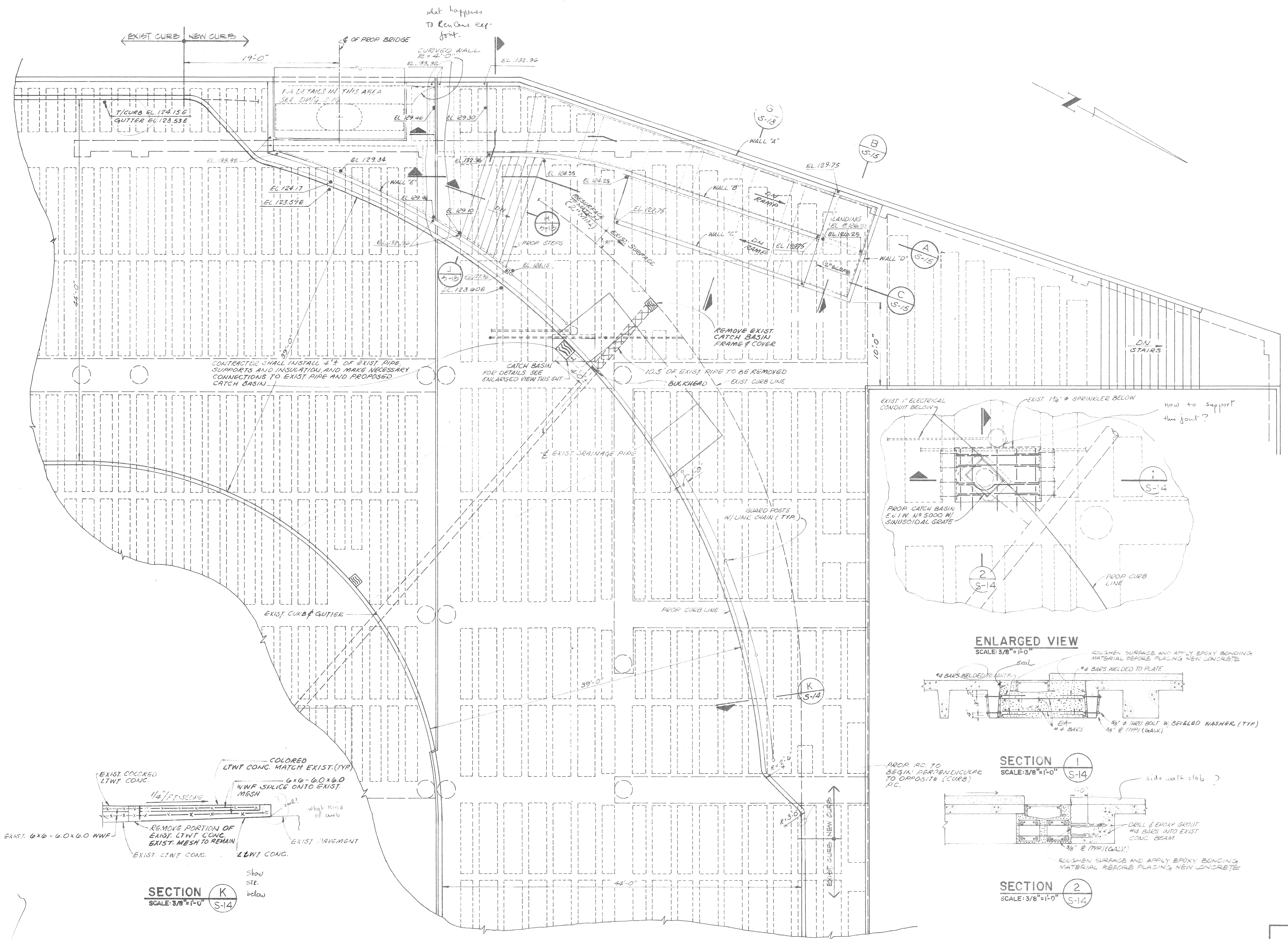

SECTION K
SCALE: 3/8"=1'-0"

ENLARGED VIEW
SCALE: 3/8"=1'-0"

SECTION 1
SCALE: 3/8"=1'-0"

SECTION 2
SCALE: 3/8"=1'-0"

RENAISSANCE PLAZA RECONSTRUCTION PLAN
SCALE: 3/16"=1'-0"

REVISION	DATE	BY	CHKD	APP'D
CITY OF DETROIT				
CITY ENGINEERING DEPARTMENT				
CITY BRIDGE No. BP-27				
Project		Sheet Title		
RANDOLPH STREET PEDESTRIAN BRIDGE		RENAISSANCE PLAZA RECONSTRUCTION DETAILS		
MADISON INTERNATIONAL OF MICHIGAN Engineers, Architects, Planners 1420 Washington Blvd. Detroit, Michigan 48226				
DESIGN BY KCH/S.O.				
DRAWN BY L.S./R.M.				
CHECKED BY P.A.				
DATE NOVEMBER, 87				
PROJECT NO. 8612				
SHEET NO. S-14				

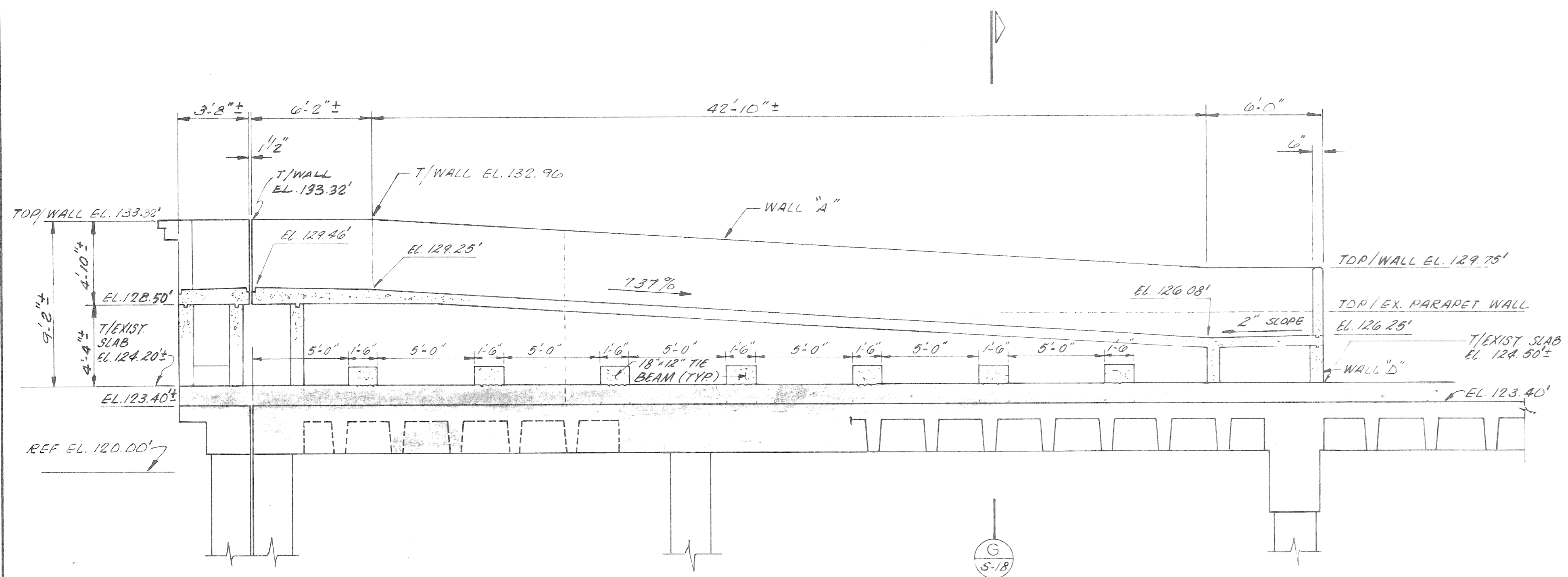

SECTION A
SCALE: 1/4" = 1'-0"
S-14

is section D void

is section E void

is it void (Section B)

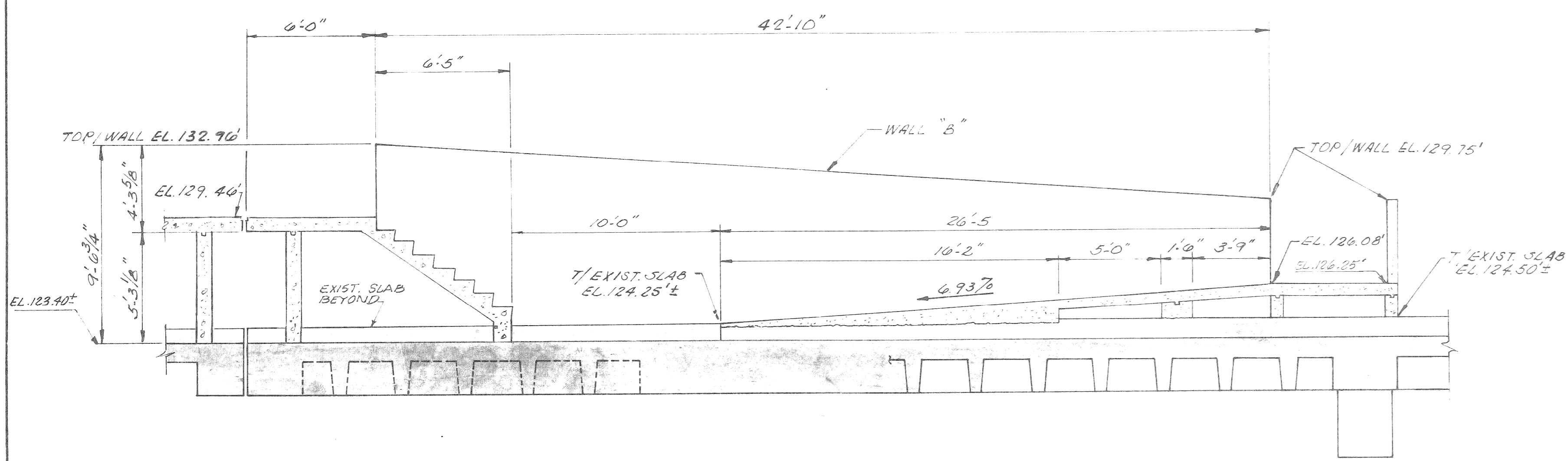

SECTION C
SCALE: 1/4" = 1'-0"
S-14

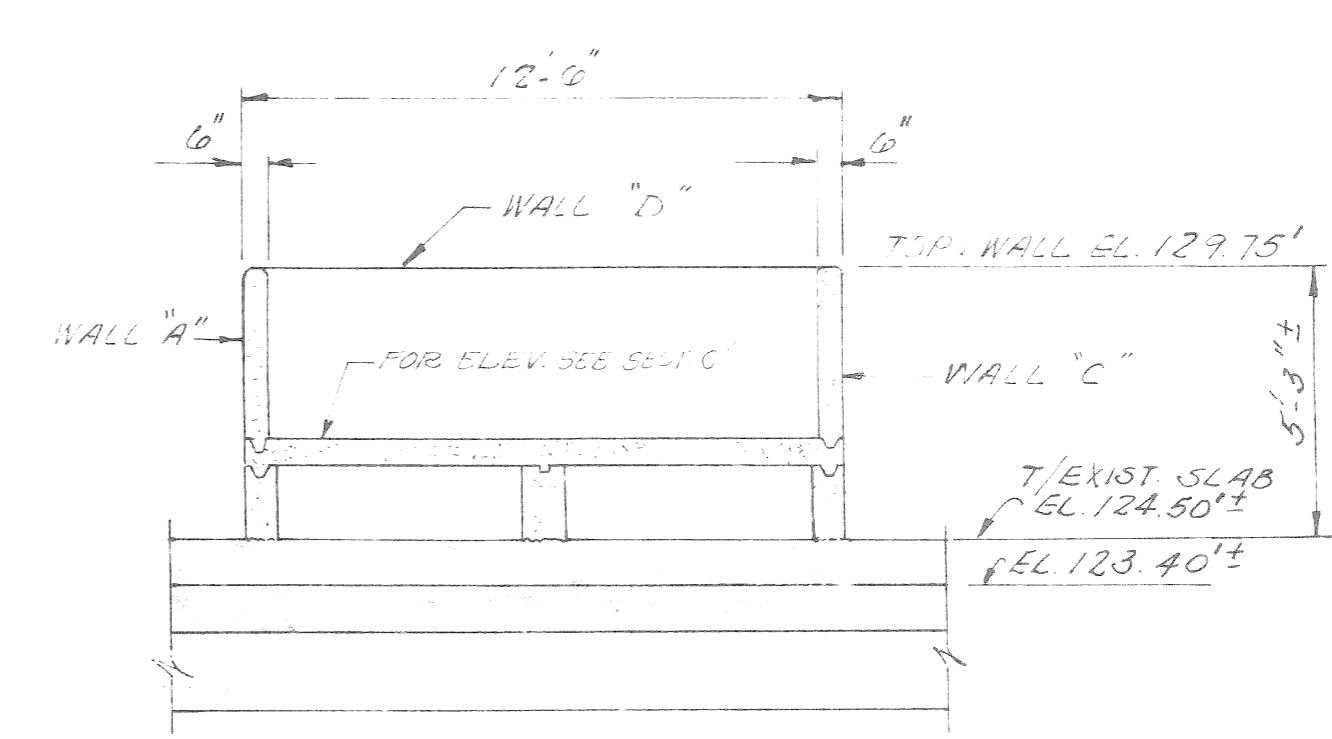

SECTION B
SCALE: 1/4" = 1'-0"
S-14

REVISION	DATE	BY	APP'D
CITY OF DETROIT			
CITY ENGINEERING DEPARTMENT			
CITY BRIDGE No. BP-27			
Project	Renaissance Plaza Reconstruction Details		
Sheet Title	Renaissance Plaza Reconstruction Details		
MADISON INTERNATIONAL OF MICHIGAN	Engineers, Architects, Planners 1420 Washington Blvd Detroit, Michigan 48226		
DESIGN BY	K.C.H./S.D.		
DRAWN BY	C.J.B.		
CHECKED BY	P.A.		
DATE	NOVEMBER, 89		
PROJECT NO.	8612		
SHEET NO.	S-15		

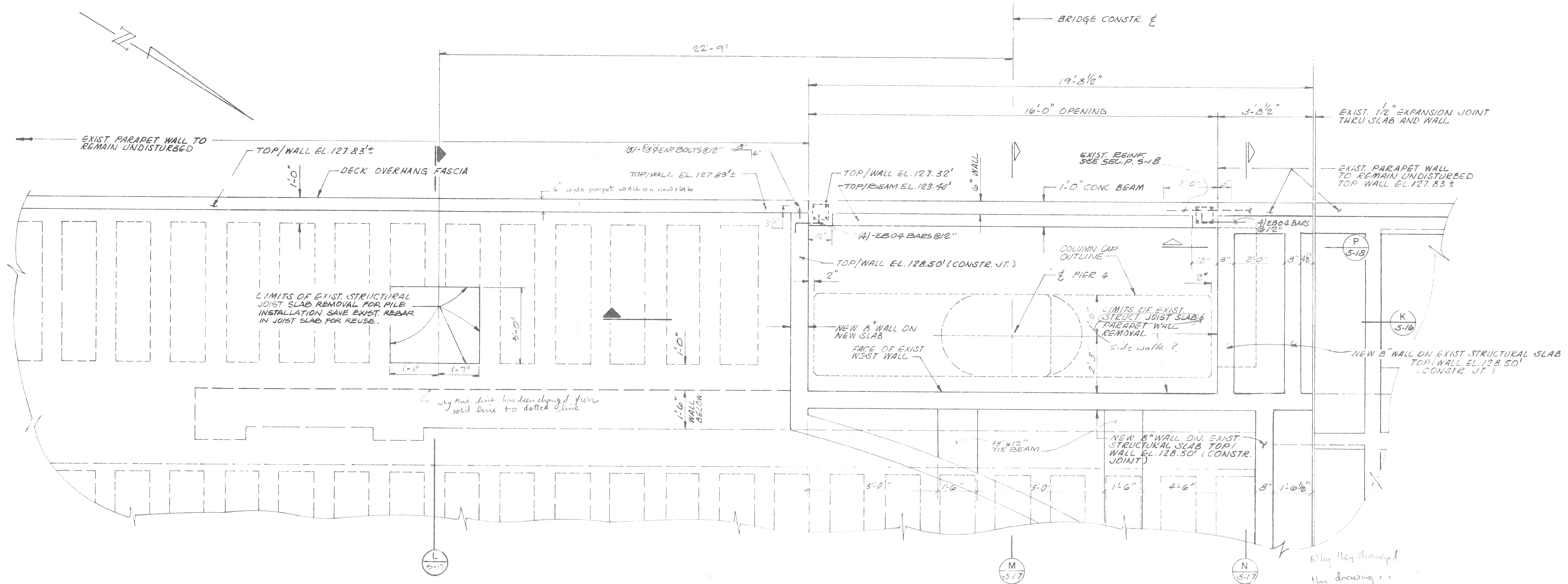

SECTION PLAN AT EL. 128.50'
SCALE: 1/2"=1'-0"

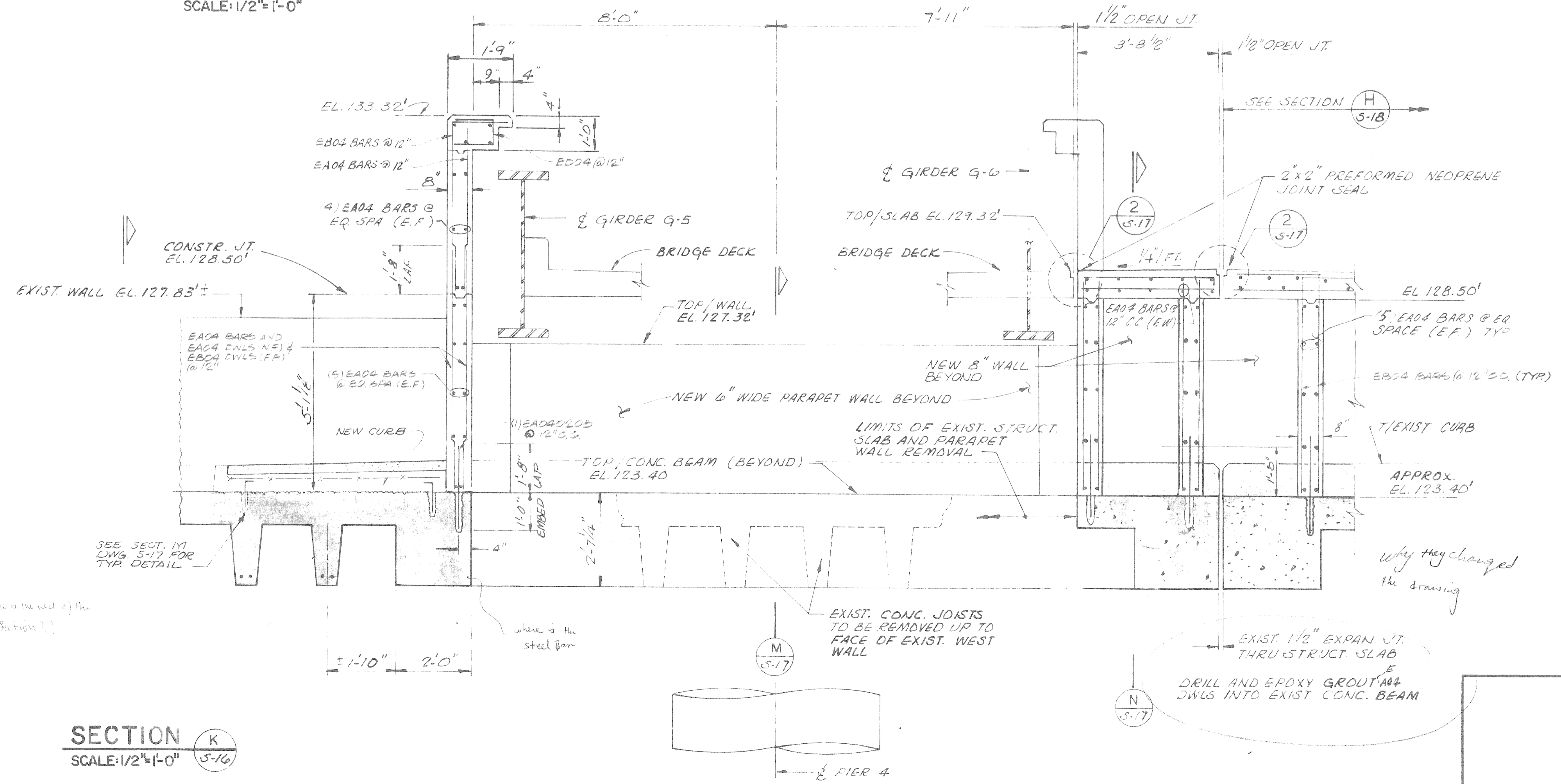

SECTION K 5-16
SCALE: 1/2"=1'-0"

DATE: NOV. 89	REVISION: 1. REVISED FOR DETROIT ENGINEERING DEPARTMENT
CITY OF DETROIT	
CITY ENGINEERING DEPARTMENT	
CITY BRIDGE No. BP-27	
Project	RANDOLPH STREET PEDESTRIAN BRIDGE
Sheet Title	RENAISSANCE PLAZA RECONSTRUCTION DETAILS
Project	MADISON INTERNATIONAL OF MICHIGAN
Engineers, Architects, Planners	1420 Washington Detroit, Michigan 48226
DESIGN BY	K.C.H./S.D.
DRAWN BY	C.J.B.
CHECKED BY	P.A.
DATE	NOVEMBER, 89
PROJECT NO.	8612
SHEET NO.	S-16

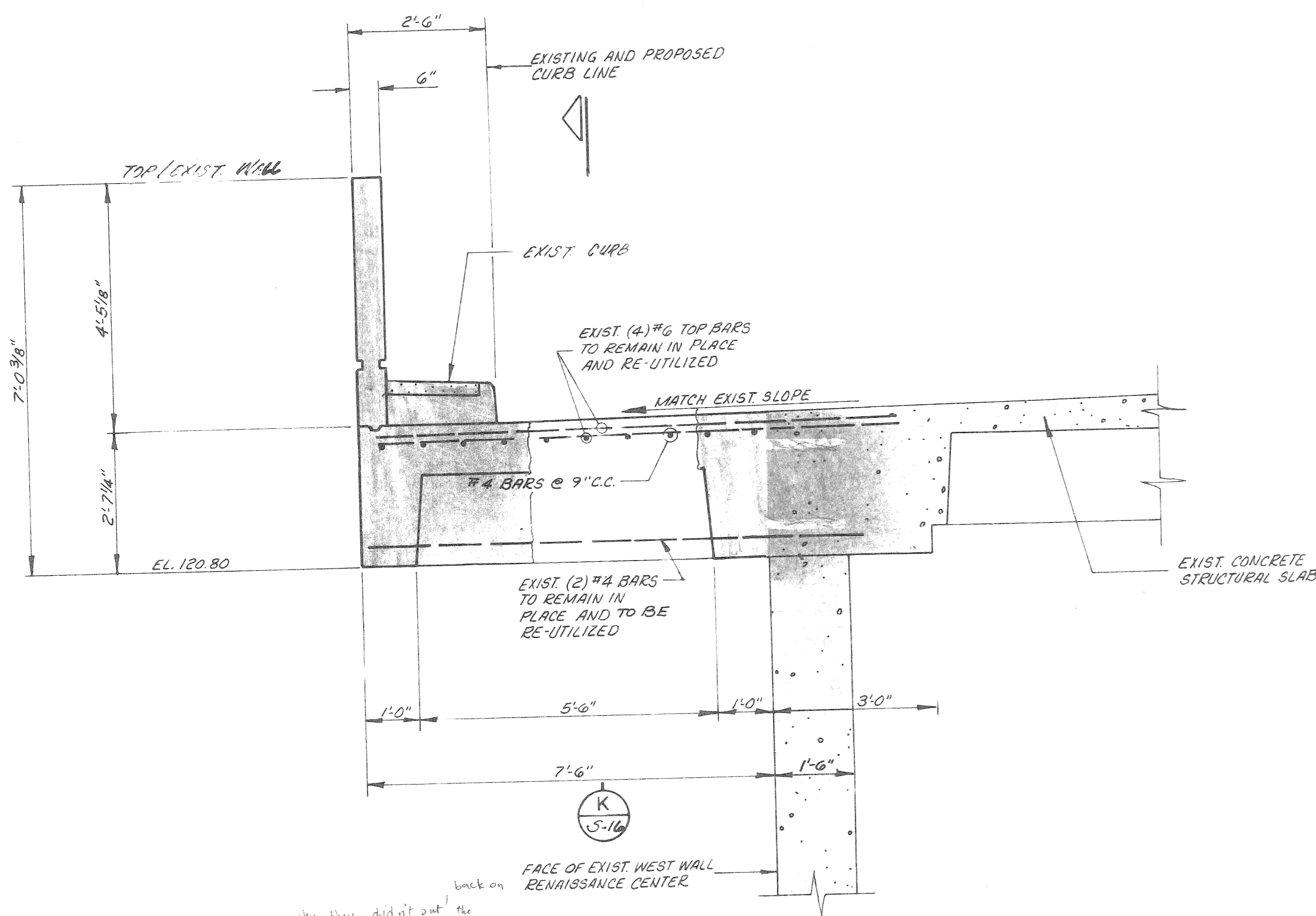

SECTION L
SCALE: 1/2" = 1'-0"
S-16

why they didn't put the details which is shown on set No. 1

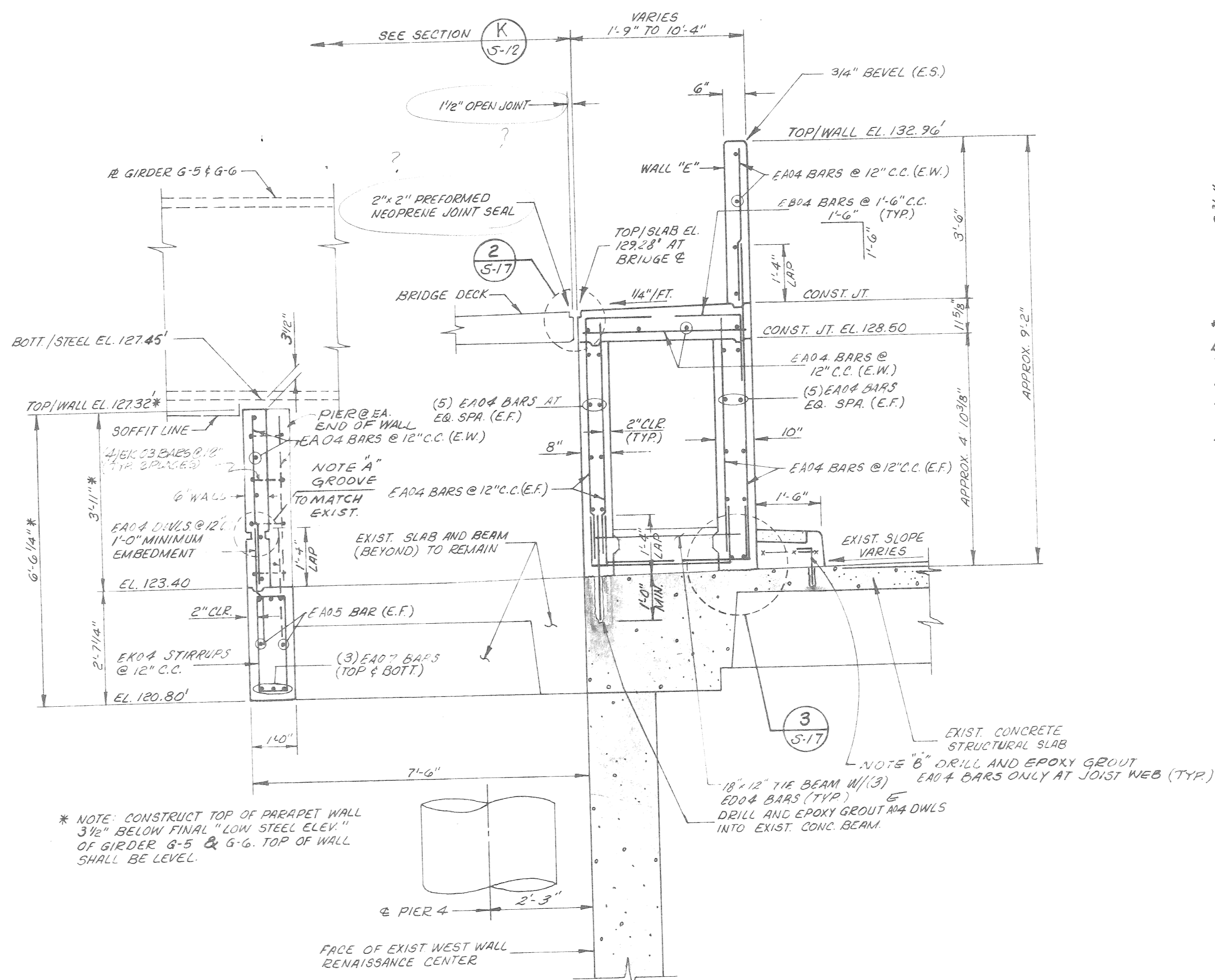

SECTION M
SCALE: 1/2" = 1'-0"
S-16

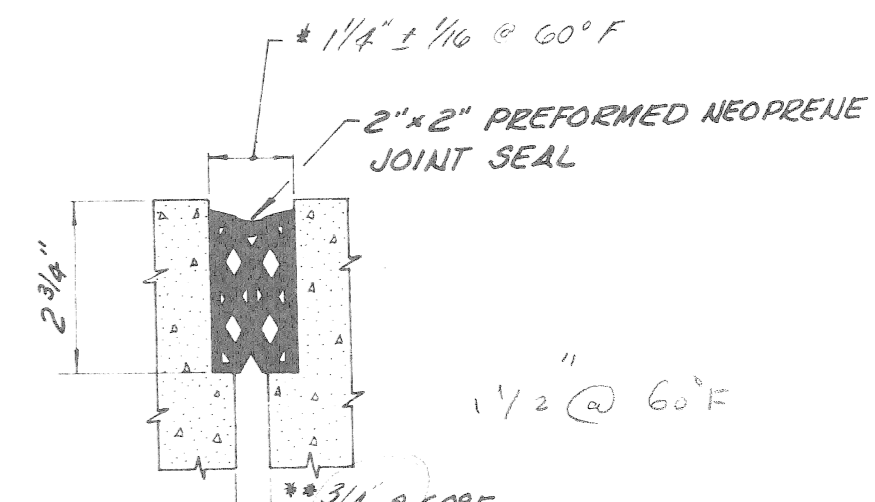

*INCREASE BY 1/16" FOR EACH 10° OF BEAM TEMP. BELOW 60° F FOR EVERY 10' OF SLAB LENGTH OR DECREASE BY 1/16" FOR EACH 10° OF BEAM TEMP. ABOVE 60° F FOR EVERY 10' OF SLAB LENGTH (SLAB LENGTH IS MEASURED AT RIGHT ANGLES TO THE JOINT.)

DETAIL 2
N.T.S.
S-17

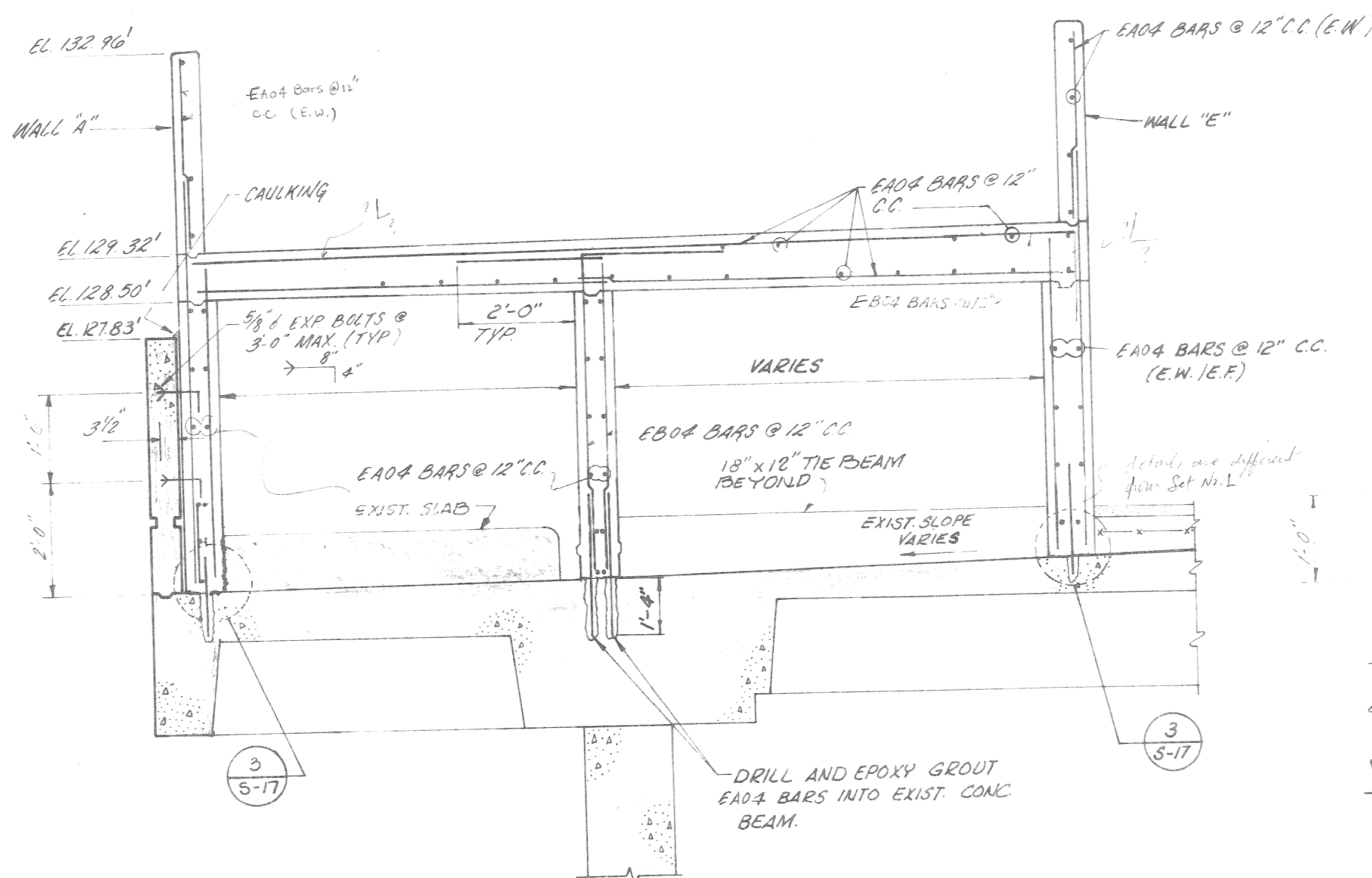

SECTION N
SCALE: 1/2" = 1'-0"
S-16

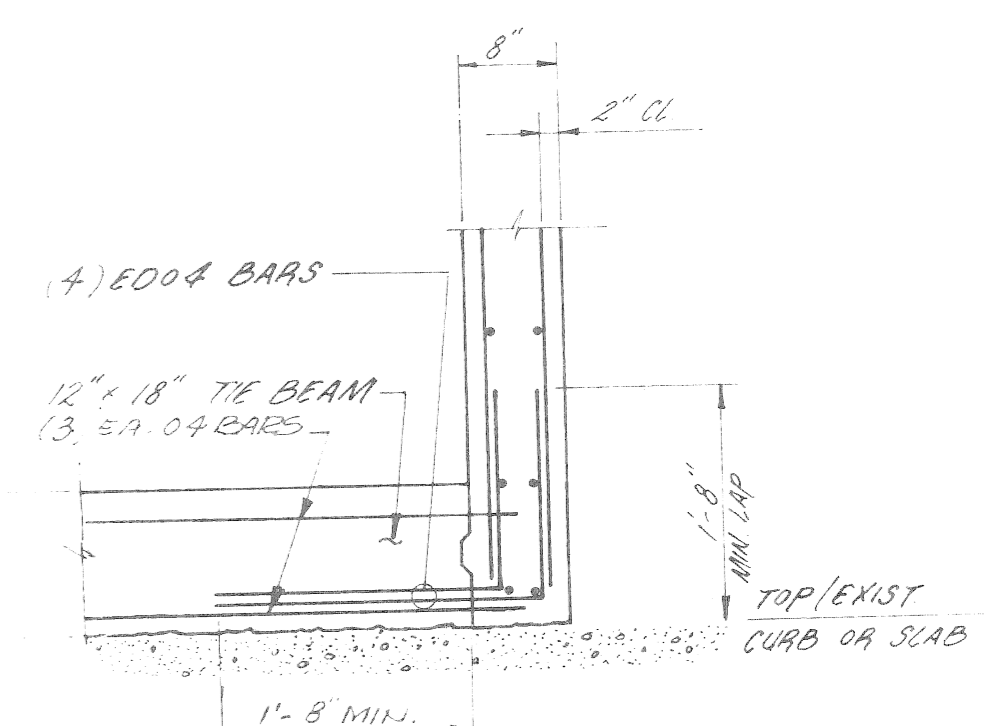

NOTE
ROUGHEN EXIST CONC SURFACE AND APPLY EPOXY BOND BEFORE PLACING NEW CONCRETE

WALL / TIE BEAM DETAIL 3
SCALE: 3/4" = 1'-0"
S-17

the detail for alternate which is shown on detail 3

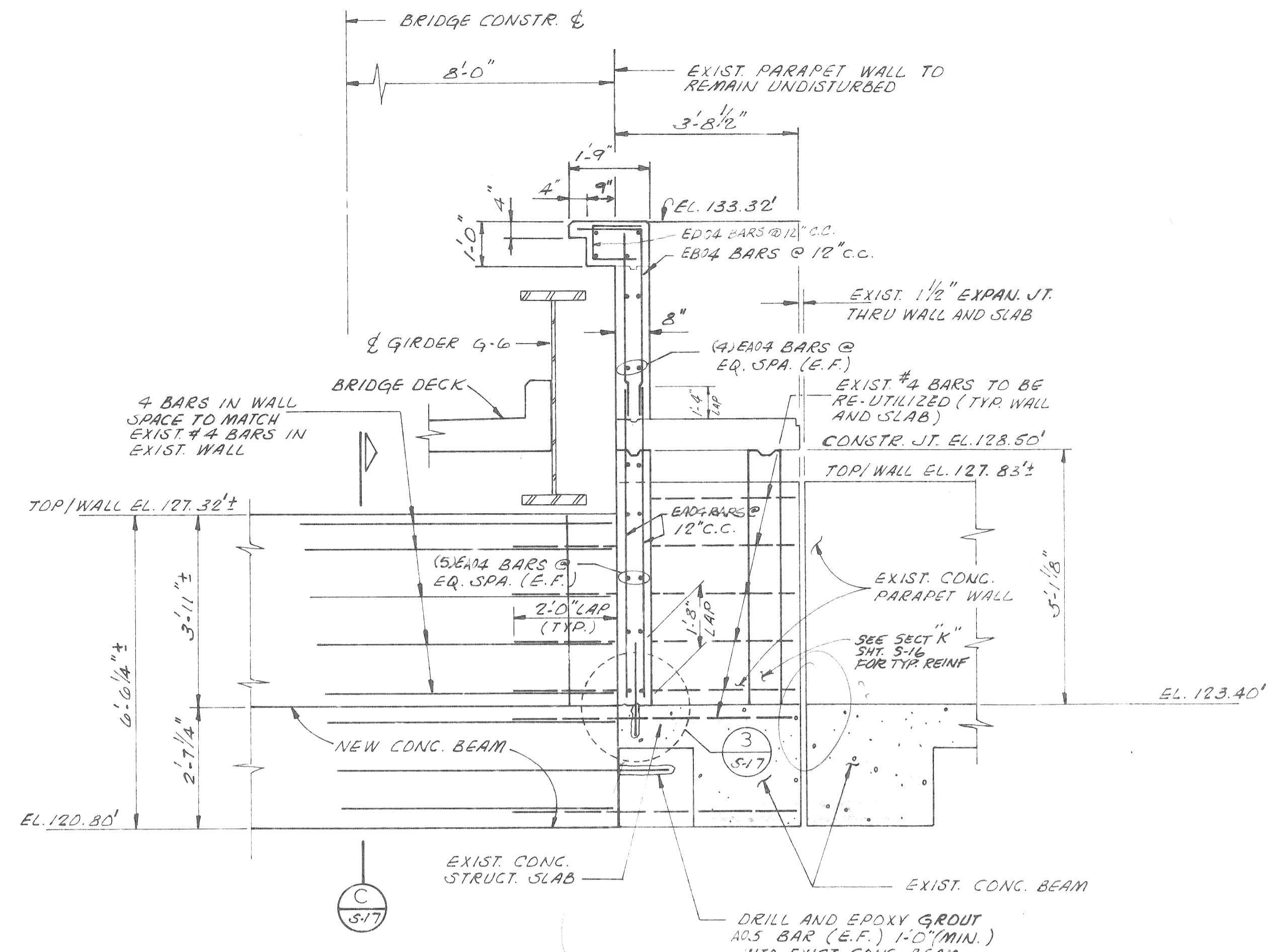

SECTION P
SCALE: 1/2"=1'-0"
S-16

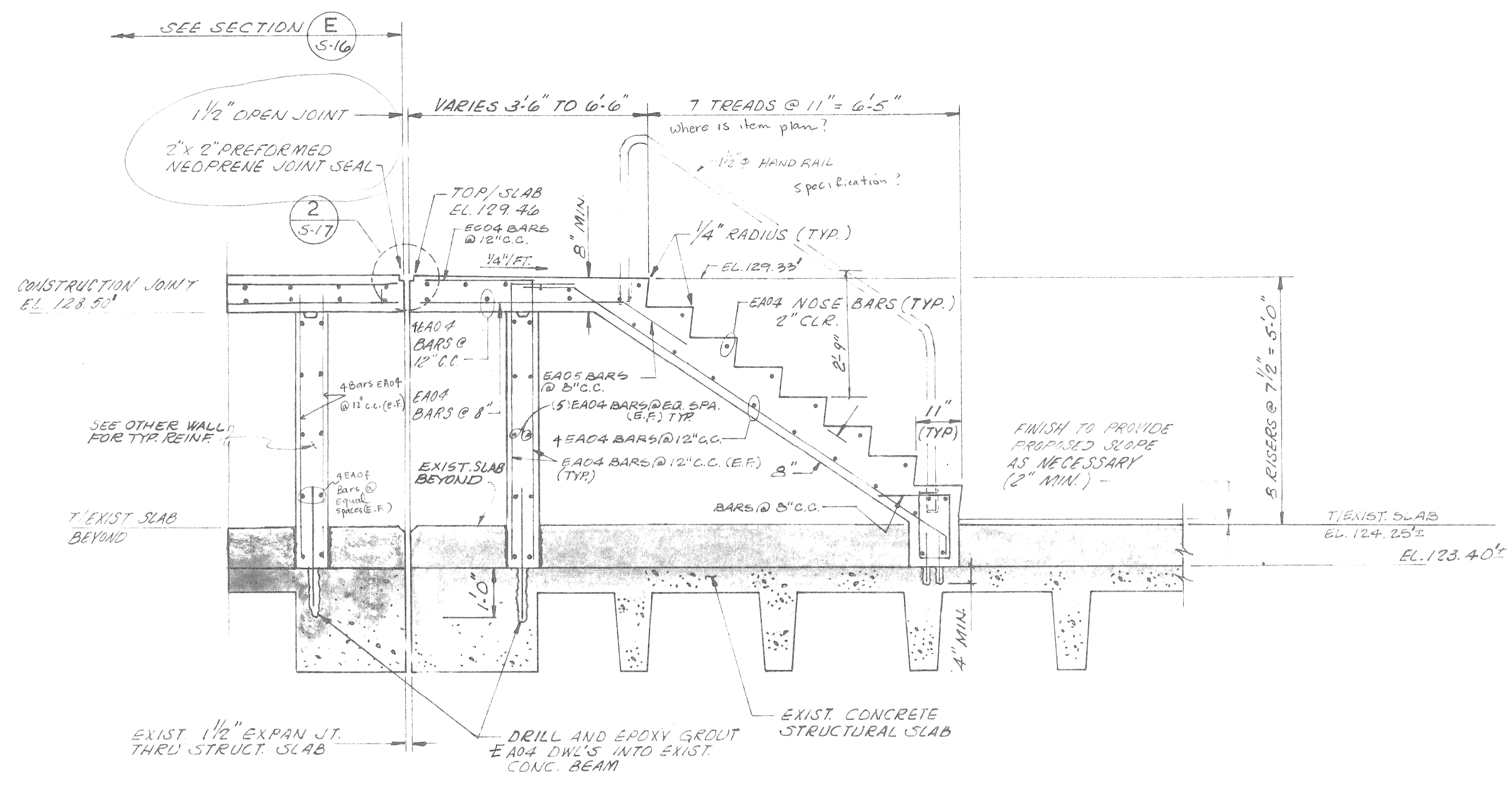

SECTION H
SCALE: 1/2"=1'-0"
S-16

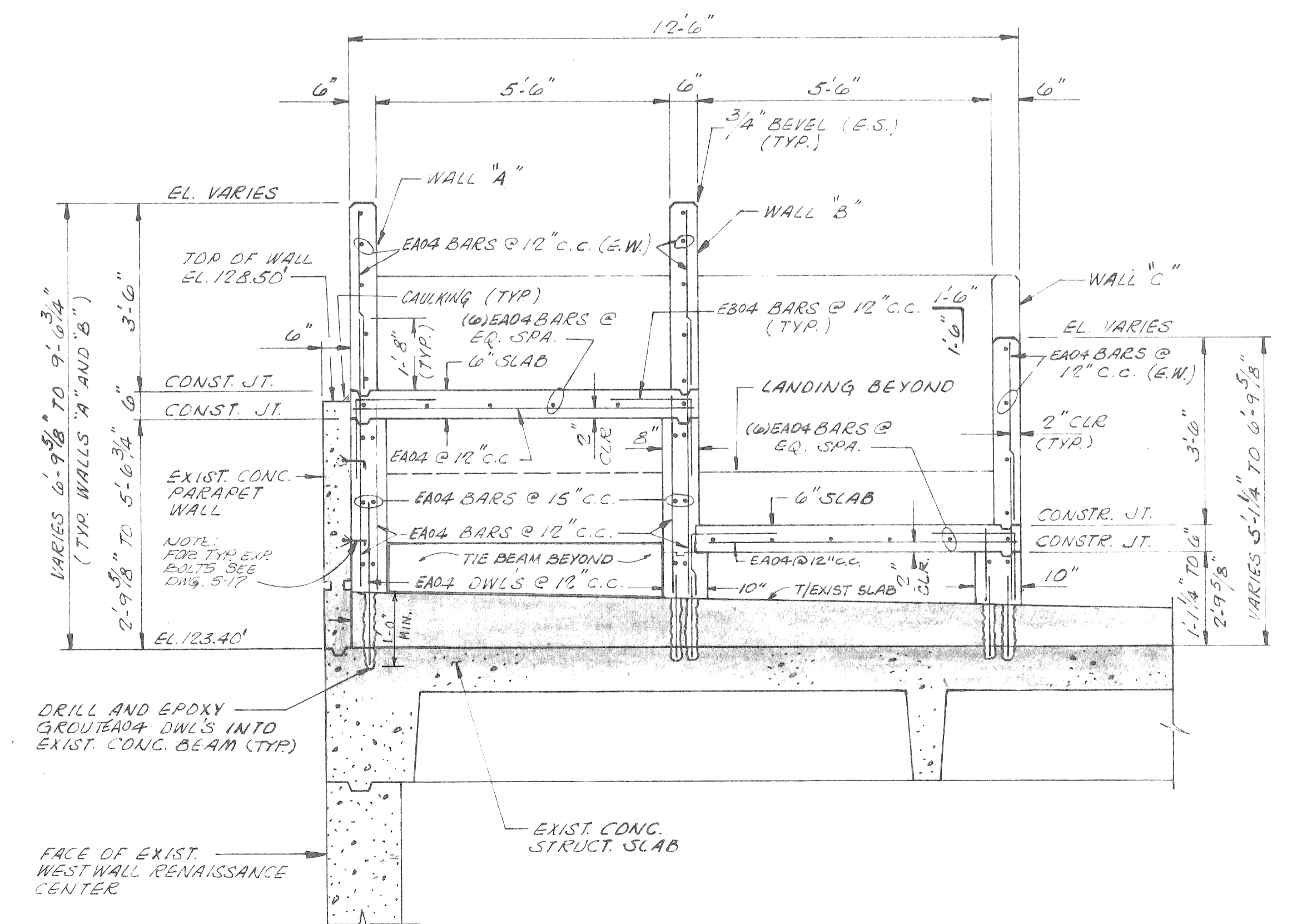

SECTION G
SCALE: 1/2"=1'-0"
S-14

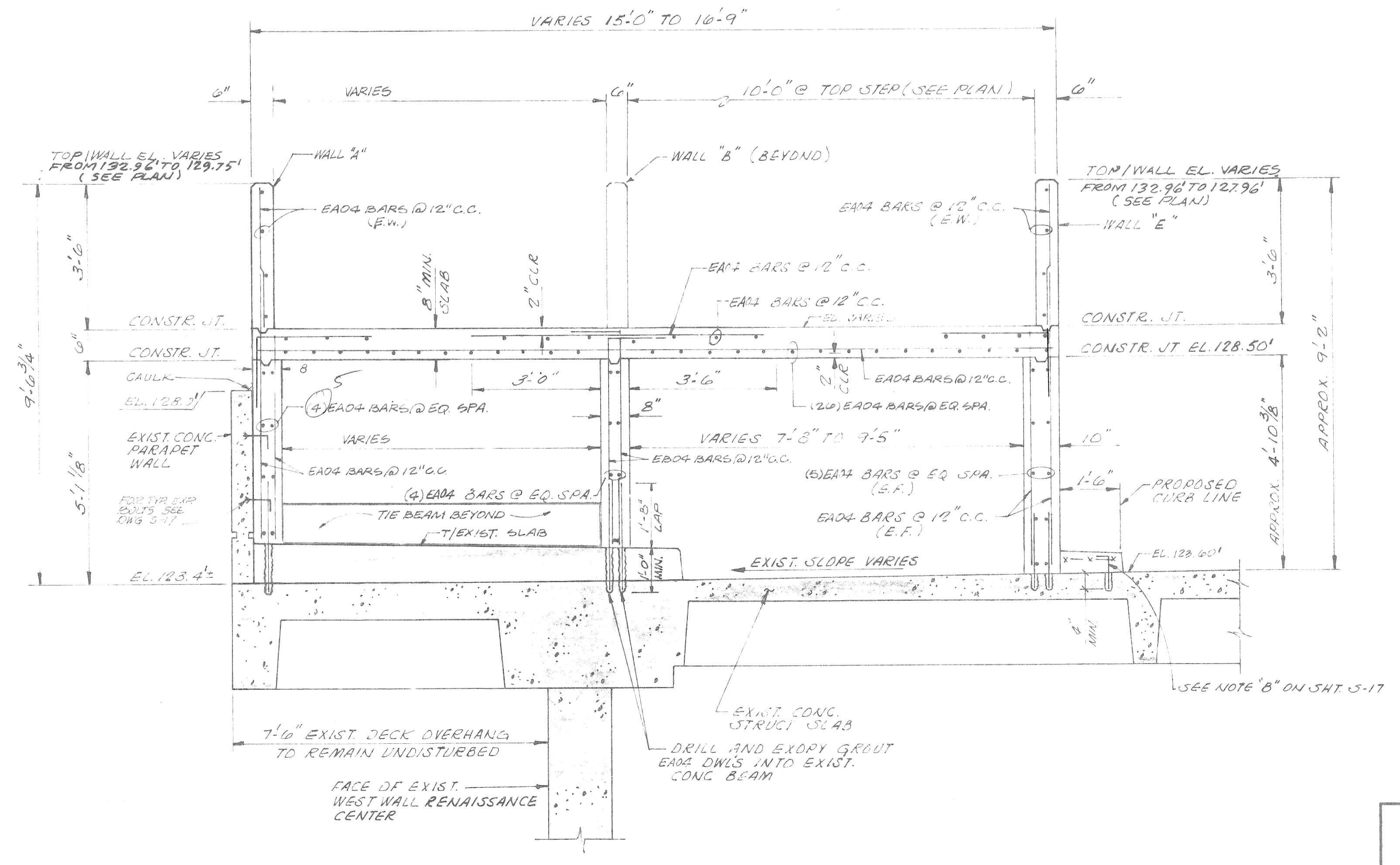

SECTION J
SCALE: 1/2"=1'-0"
S-14

DATE: 10/27/89	REVISION: 10/27/89
CITY OF DETROIT	
CITY ENGINEERING DEPARTMENT	
CITY BRIDGE No. BP-27	
Project: RANDOLPH STREET PEDESTRIAN BRIDGE	Sheet Title: RENAISSANCE PLAZA RECONSTRUCTION DETAILS
MADISON INTERNATIONAL OF MICHIGAN	Engineers, Architects, Planners 1420 Washington Blvd. Detroit, Michigan 48226
DESIGN BY: K.C.H./S.D.	DRAWN BY: C.J.B.
CHECKED BY: P.A.	DATE: NOVEMBER, 89
PROJECT NO. 8612	SHEET NO. S-18

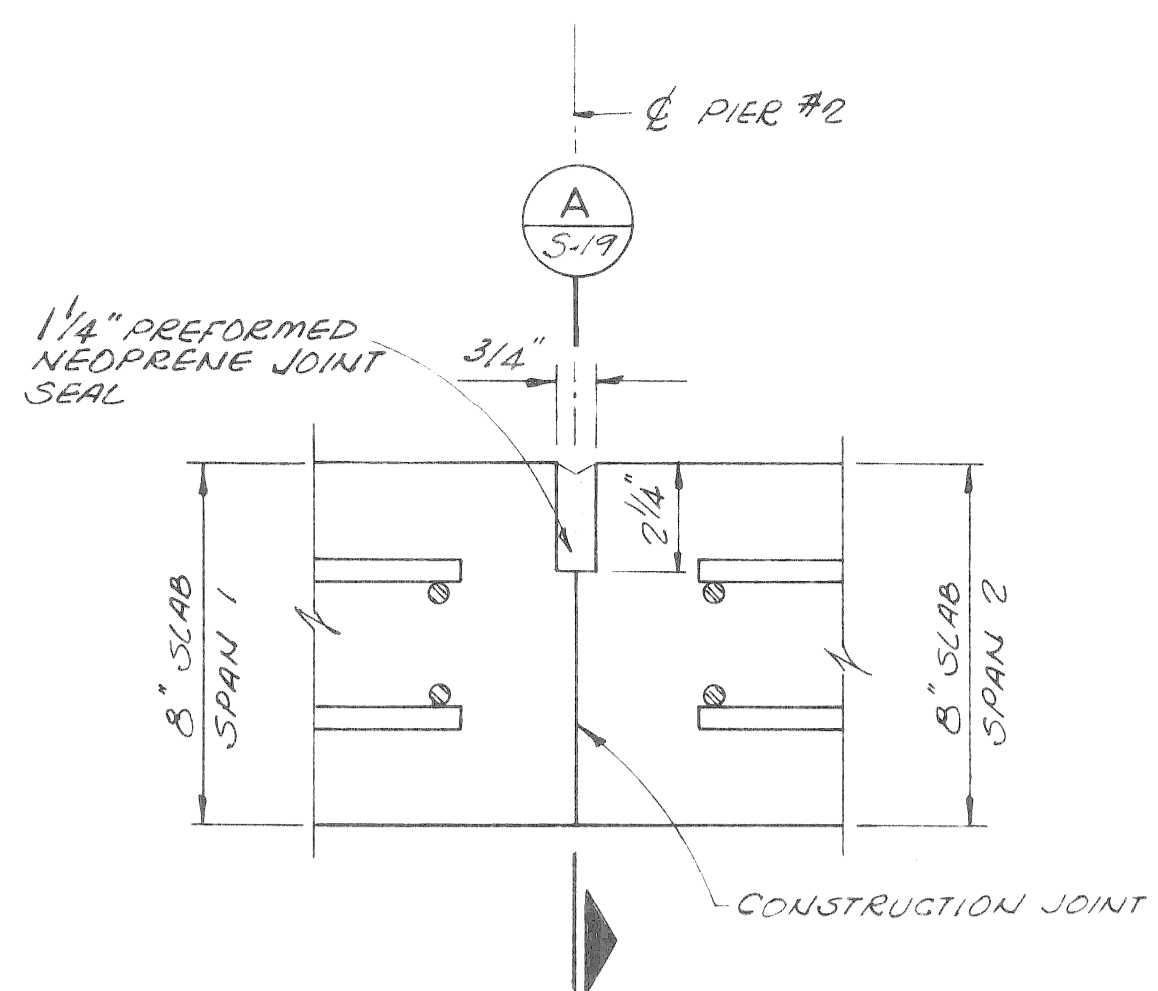

**TRANSVERSE SLAB
CONSTR. JOINT
PIER 2
NTS.**

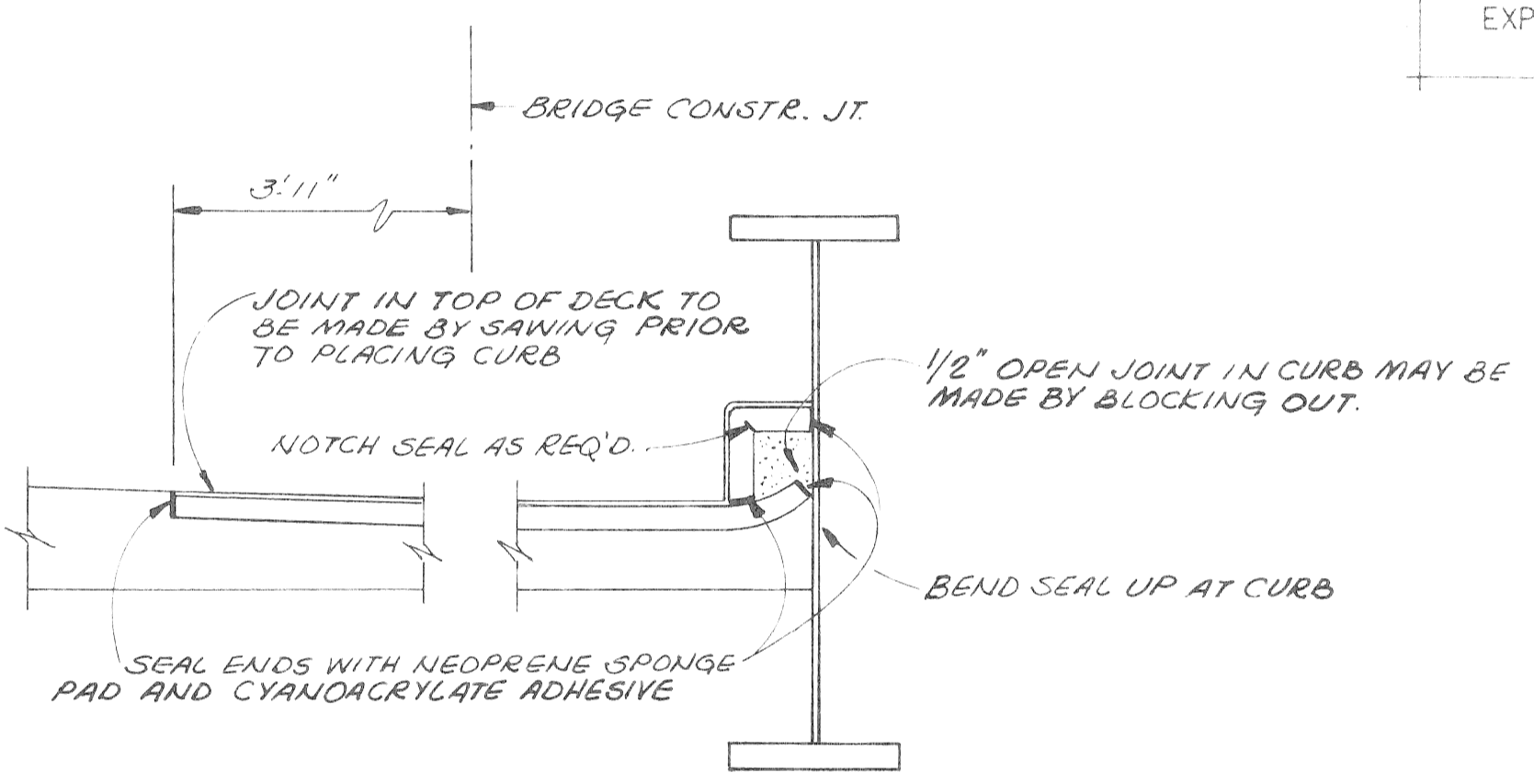

**SECTION A
SCALE: 3/4\"/>**

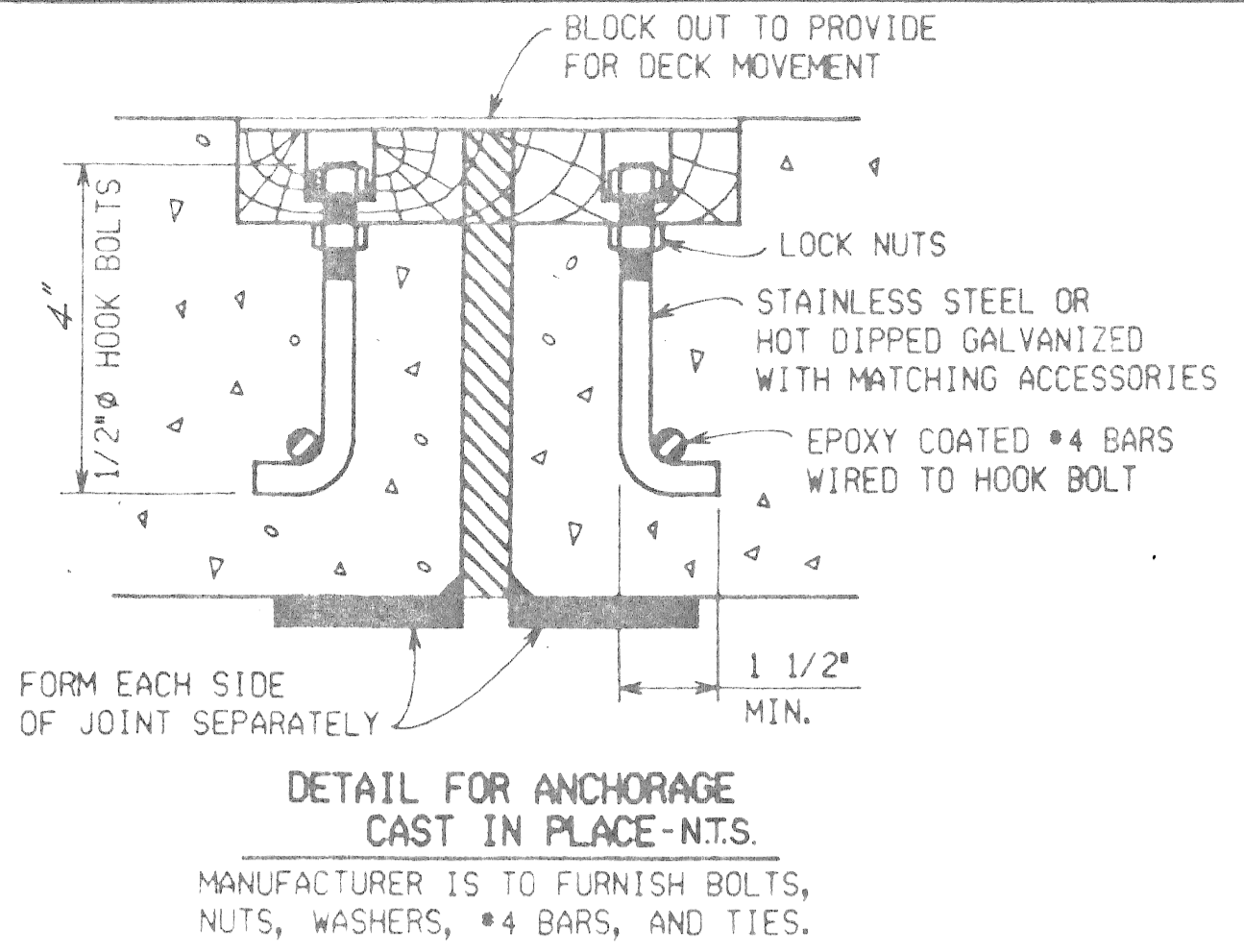

**DETAIL FOR ANCHORAGE
CAST IN PLACE NTS.**
MANUFACTURER IS TO FURNISH BOLTS, NUTS, WASHERS, #4 BARS, AND TIES.

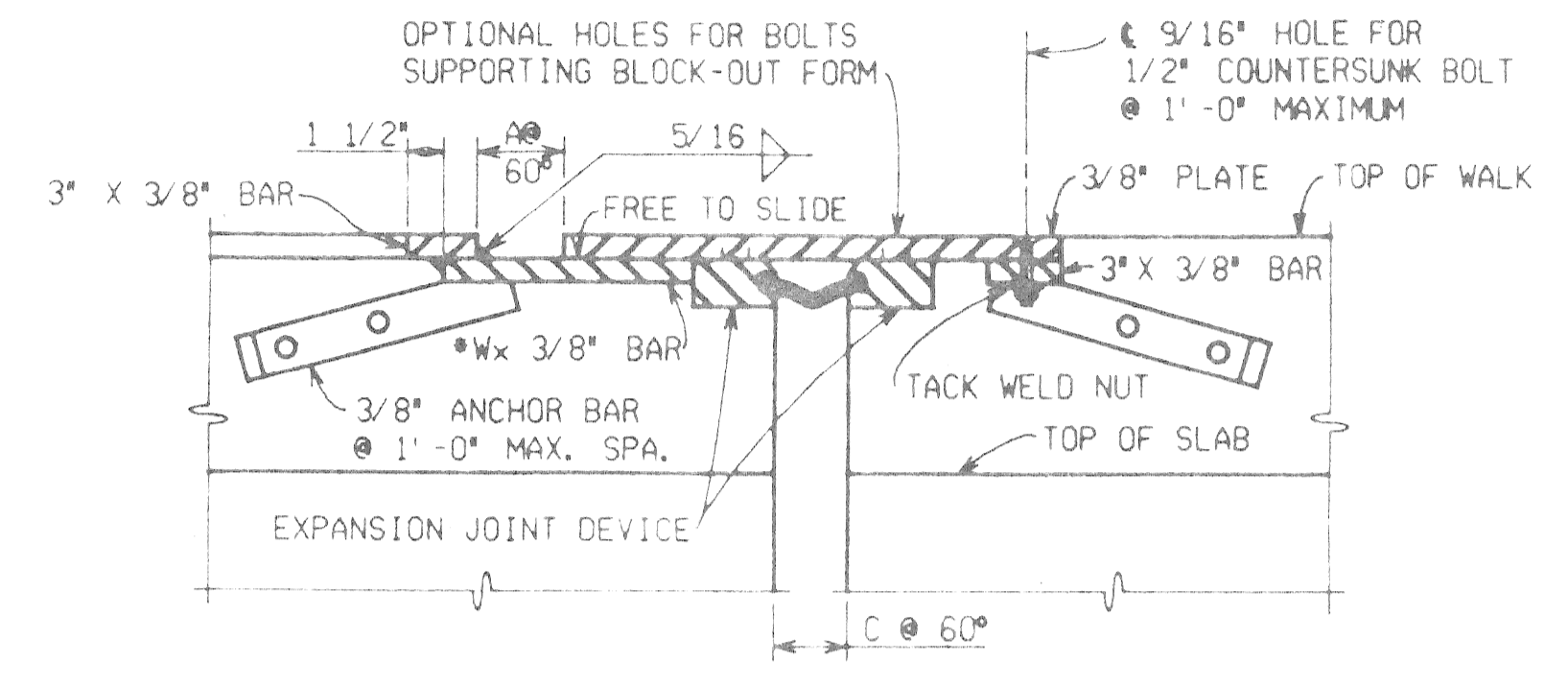

DETAIL 1 @ PIER 3 (TOTAL TRAVEL = 2 3/8\"/>

SCALE: 1 1/2\"/>

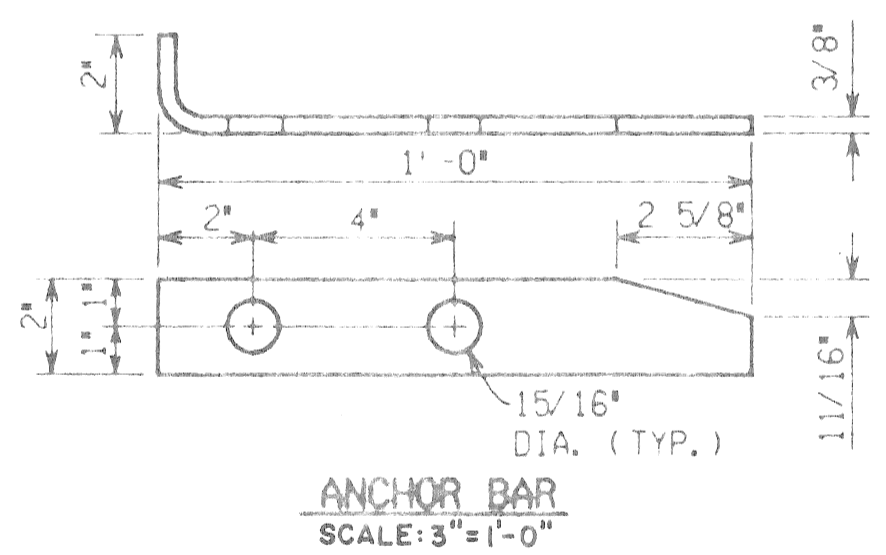

**ANCHOR BAR
SCALE: 3\"/>**

NOTES:

JOINT TYPES
THE EXPANSION JOINT DEVICE SHALL BE OF A TYPE THAT INCLUDES A CONTINUOUS NEOPRENE (OR EQUIVALENT) SEAL ACROSS THE DECK. UNLESS OTHERWISE NOTED ON THE PLANS, THE CONTRACTOR HAS THE OPTION OF USING ANY OF THE DEVICES LISTED BELOW:

DEVICE	MANUFACTURER
WATSON-BOWMAN STRIP SEAL, ELASTOFLEX DNIFLEX (Elastomeric Side Panels)	WATSON-BOWMAN & ACME, INC. STRUCTURAL ACCESSORIES, INC.
PRO-SPAN, FEL-SPAN CS AND MULTIFOLD GEN-STRIP	FEL-PRO, INC. GENERAL TIRE
STRELFLEX-RS	D. S. BROWN

THE MODEL OF THE JOINT TYPE SELECTED SHALL BE SUITABLE TO ACCOMMODATE THE TOTAL MOVEMENT NOTED ON THE PLANS.

COMPLETE WORKING DRAWINGS OF ALL DETAILS OF FABRICATION OF THE EXPANSION JOINT DEVICE SHALL BE SUBMITTED FOR REVIEW IN ACCORDANCE WITH STANDARD SPECIFICATION 1.05.03.

FABRICATION AND INSTALLATION

THE EXPANSION JOINT SHALL BE SHOP FABRICATED TO CONFORM TO THE CONTOUR OF THE BRIDGE DECK, BARRIERS, ETC. IT SHALL BE INSTALLED IN ACCORDANCE WITH MANUFACTURER'S RECOMMENDATIONS SUBJECT TO NOTES HEREIN AND THE APPROVAL OF THE ENGINEER.

THE PRO-SPAN DEVICE MUST INCORPORATE A CAST-IN-PLACE METAL SEAT.

WHERE THE DEVICE IS TO BE INSTALLED ON CAST CONCRETE, THE SURFACE CRIBS SHALL BE REMOVED BY SANDBLASTING AND ANY VOIDS FILLED WITH EPOXY MORTAR PRIOR TO BEDDING.

THE AREA OF THE HOLD-DOWN DEVICE AND SEALING GLAND WHICH WILL BE IN CONTACT WITH A SEALANT, BEDDING COMPOUND, OR LUBRICANT-ADHESIVE SHALL BE CLEANED WITH TOLUENE OR OTHER APPROVED SOLVENT.

A BEDDING COMPOUND SHALL BE USED BETWEEN THE SEAT AND THE ANCHORED PORTION OF THE SEALING GLAND, OR BETWEEN THE SEAT AND HOLD-DOWN DEVICE. THE BEDDING COMPOUND SHALL BE AN APPROVED EPOXY GROUT FURNISHED BY THE MANUFACTURER OF THE EXPANSION JOINT DEVICE.

WHERE THE SEALING GLAND IS LOCKED INTO A METAL EXTRUSION, A LUBRICANT-ADHESIVE CONFORMING TO STANDARD SPECIFICATION 8.16.04-d SHALL BE REQUIRED BETWEEN THE SEAL AND METAL EXTRUSION.

ALL CONTINUOUS BOLT WELL CAVITIES IN THE HOLD-DOWN DEVICES SHALL BE FILLED WITH AN EPOXY MORTAR. ALL NON-CONTINUOUS BOLT WELL CAVITIES SHALL BE FILLED WITH AN APPROVED FLEXIBLE EPOXY OR A SEALANT CONFORMING TO FEDERAL SPECIFICATION TT-S-002300.

THE VOID FORMED BETWEEN THE VERTICAL EDGE OF THE HOLD-DOWN DEVICE AND THE BLOCK-OUT SHALL BE FILLED WITH A SEALANT IF LESS THAN 1/2 INCH IN WIDTH OR WITH AN EPOXY MORTAR IF GREATER THAN 1/2 INCH. THE SEALANT SHALL CONFORM TO FEDERAL SPECIFICATION TT-S-002300 OR SHALL BE AN APPROVED FLEXIBLE EPOXY.

THE EPOXY MORTAR USED TO REPAIR THE SEAT, TO FILL THE CONTINUOUS BOLT WELL CAVITIES, AND TO FILL THE VOID BETWEEN THE EDGE OF THE HOLD-DOWN DEVICE AND THE BLOCK-OUT SHALL BE MIXED AND PLACED IN ACCORDANCE WITH STANDARD SPECIFICATION 4.06.13-a, EXCEPT THE SAND SHALL BE LIMITED TO A MAXIMUM OF 2.5 PARTS, USING AN EPOXY BINDER MEETING THE REQUIREMENTS SPECIFIED IN STANDARD SPECIFICATION 8.16.03. ALL SURFACES IN CONTACT WITH THE EPOXY MORTAR SHALL BE LIGHTLY SANDBLASTED AND PRIMED WITH THE BINDER PRIOR TO PLACING THE MORTAR.

DETAILS - CURBS OR BARRIERS

THE DETAILS ON THIS SHEET SHOW AN APPROVED MEANS OF TERMINATING THE EXPANSION JOINT DEVICE AT CURBS OR BARRIERS. VARIATIONS OR ALTERNATIVE SCHEMES WILL BE CONSIDERED AND MAY BE USED IF APPROVED BY THE ENGINEER.

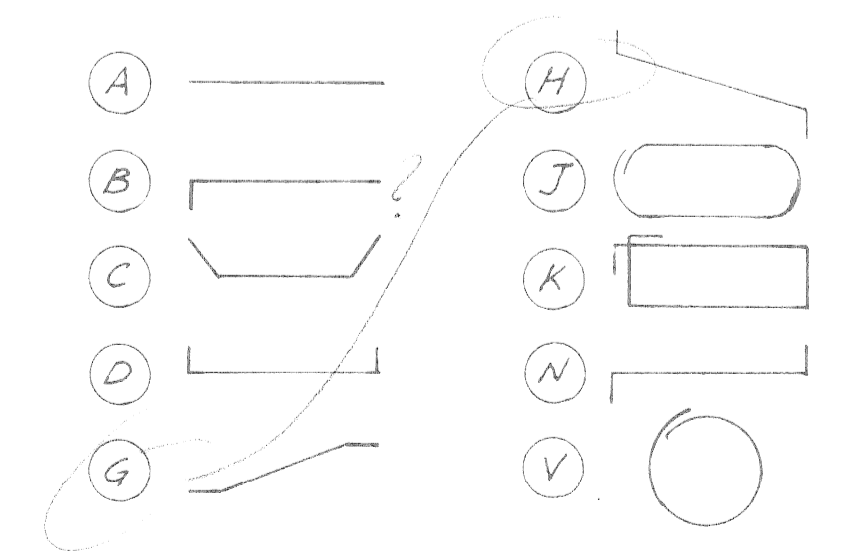

TYPICAL BAR BENDS DESIGNATIONS

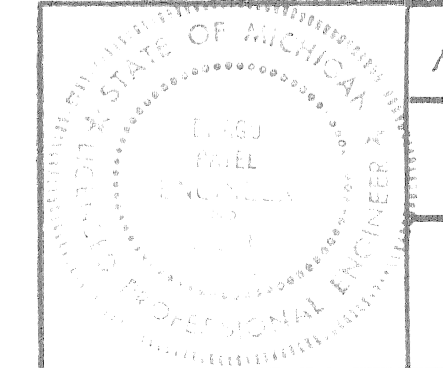

REVISION	
DATE	
CITY OF DETROIT	
CITY ENGINEERING DEPARTMENT	
CITY BRIDGE No. BP-27	
Project	RANDOLPH STREET PEDESTRIAN BRIDGE
Sheet Title	JOINT DETAILS
MADISON MADISON INTERNATIONAL OF MICHIGAN Engineers, Architects, Planners 1420 Washington Blvd. Detroit, Michigan 48226	DESIGN BY <i>K.C.H./S.O.</i> DRAWN BY <i>C.V.B.</i> CHECKED BY <i>P.A.</i>
DATE NOVEMBER, 89	PROJECT NO. 8612
SHEET NO. S-19	

TEST HOLE NO. 1

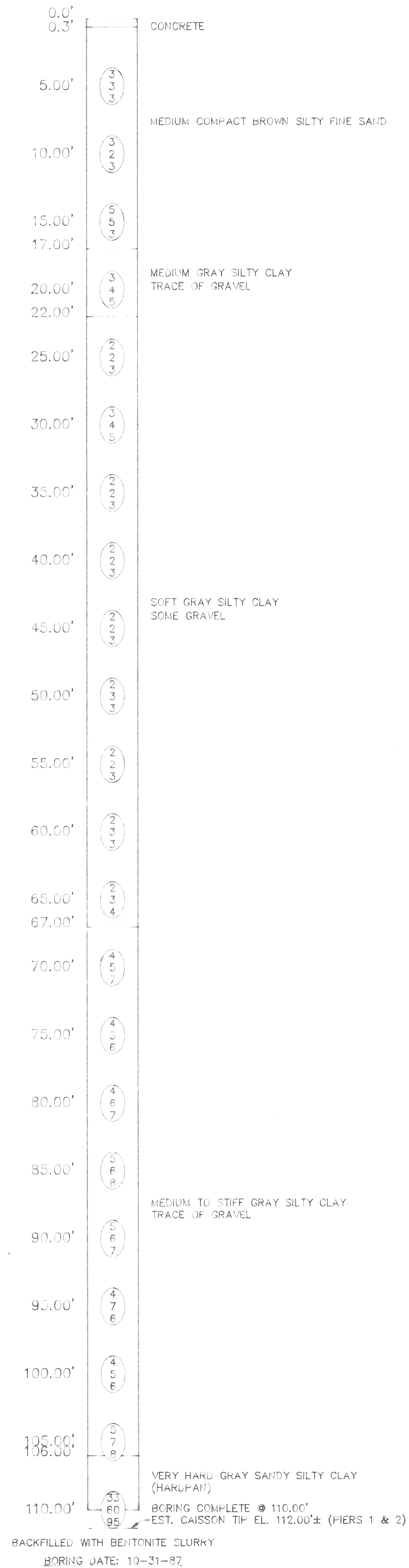

TEST HOLE NO. 2

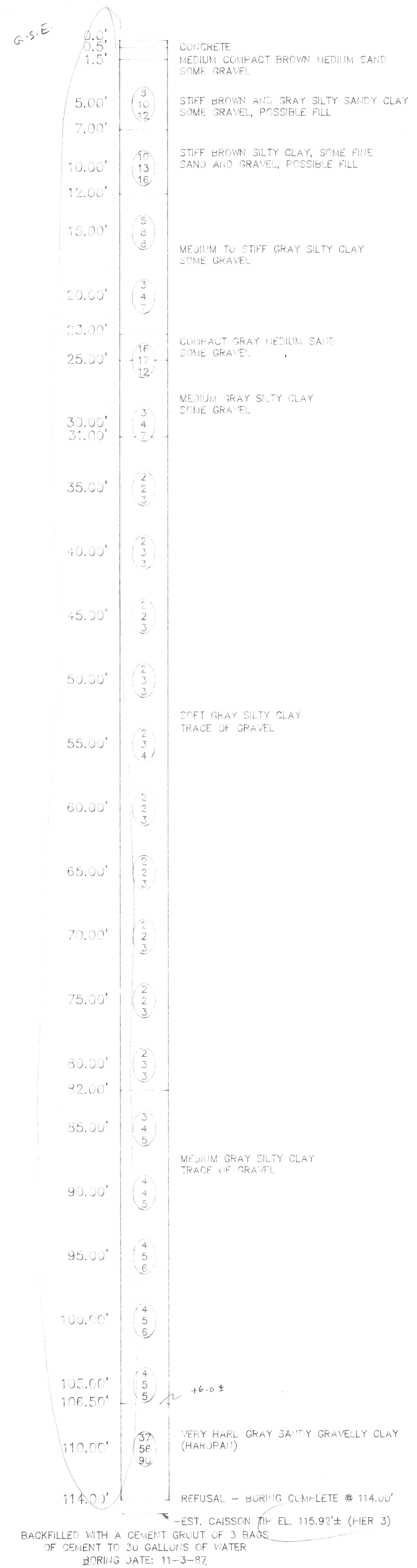

TEST HOLE NO. 3

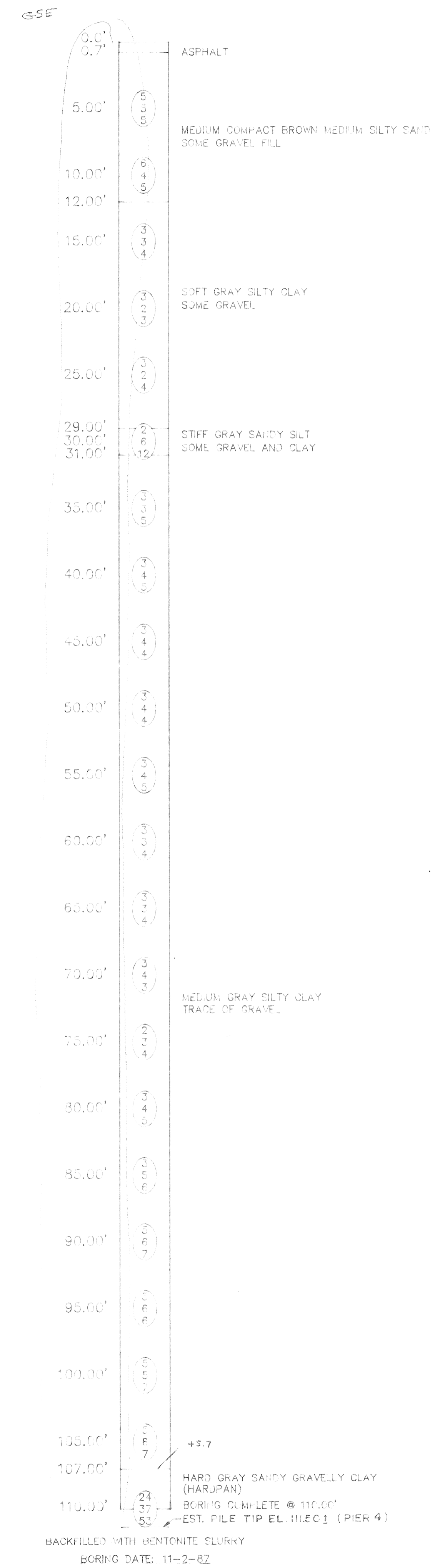

NOTES:
 0 - FIRST 6"
 1 - SECOND 6"
 2 - THIRD 6"
 NUMBERS IN CIRCLE DENOTES NUMBER OF BLOWS REQUIRED TO DRIVE A 2.00" O.D. x 1.50" I.D. SPLIT SPOON SAMPLER (3) SUCCESSIVE 6" INCREMENTS USING A 140 LB. HAMMER FALLING 3'
 THE SOIL BORING LOGS REPRESENT POINT INFORMATION. PRESENTATION OF THIS INFORMATION IN NO WAY IMPLIES THAT SUBSURFACE CONDITIONS ARE THE SAME AT LOCATIONS OTHER THAN THE EXACT LOCATION OF THE BORING.

REVISION	
DATE	
CITY OF DETROIT	
CITY ENGINEERING DEPARTMENT	
CITY BRIDGE No. BP-27	
RANDOLPH STREET PEDESTRIAN BRIDGE	
SOIL BORING LOG	
BORINGS NO.1, NO.2 AND NO.3	
MADISON MADISON INTERNATIONAL OF MICHIGAN	Engineers, Architects, Planners 1420 Washington Blvd. Detroit, Michigan 48226
DESIGN BY	S.D.
DRAWN BY	B.M.M.
CHECKED BY	P.A.
DATE	NOVEMBER, 87
PROJECT NO.	8612
SHEET NO.	SB-1

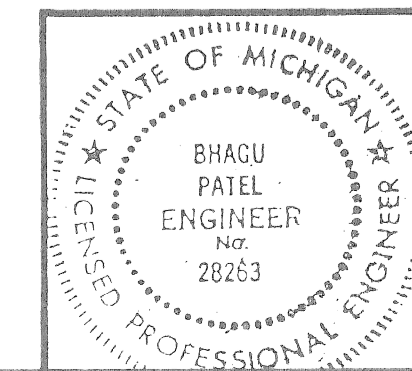

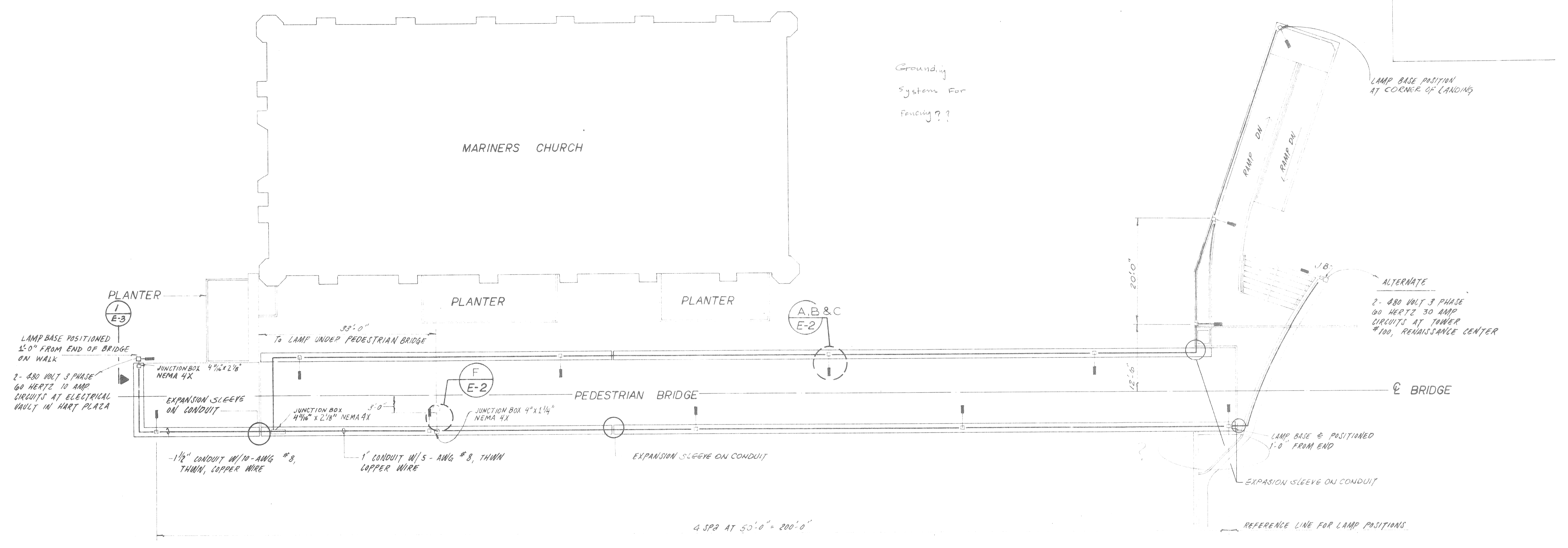

LIGHTING PLAN
SCALE: 1"=10'

- NOTES
1. THE CONDUIT RUN ON THE SOUTHSIDE OF THE OVERPASS IS ON A SEPARATE CIRCUIT THAN THE CONDUIT ON THE NORTHSIDE OF THE OVERPASS.
 2. WHEN BALANCING THE LOAD BETWEEN THE PHASES, ALTERNATE THE LIGHTS IN SUCH A MANNER THAT THERE SHALL NOT BE A LARGE DARK AREA ON THE OVERPASS OR THE RAMPS IF A PHASE IS LOST.
 3. THE CONDUIT RUN BETWEEN THE LIGHT POLES SHALL BE MOUNTED ON TOP OF THE "I" BEAM.
 4. THE CONDUIT RUN FOR THE LIGHT MOUNTED UNDER THE OVERPASS SHALL BE CONTAINED WITHIN THE PANELS OF THE OVERPASS.
 5. POWER FOR THE LIGHTS ON THE OVERPASS SHALL BE CONNECTED AT THE JUNCTION BOXES AT EITHER THE WESTEND OR THE EASTE 1 OF THE OVERPASS DEPENDING ON WHERE THE POWER SOURCE IS LOCATED.

REVISION	DATE	CITY OF DETROIT CITY ENGINEERING DEPARTMENT CITY BRIDGE No. BP-27
PROJECT: RANDOLPH STREET PEDESTRIAN BRIDGE		
SHEET TITLE: ELECTRICAL SITE PLAN		
MADISON INTERNATIONAL OF MICHIGAN Engineers, Architects, Planners 1420 Washington Blvd Detroit, Michigan 48226		
DESIGN BY	DE KECK	
DRAWN BY	M.C.	
CHECKED BY	P.A.	
DATE	NOVEMBER, 1971	
PROJECT NO.	8612	
SHEET NO.	E-1	

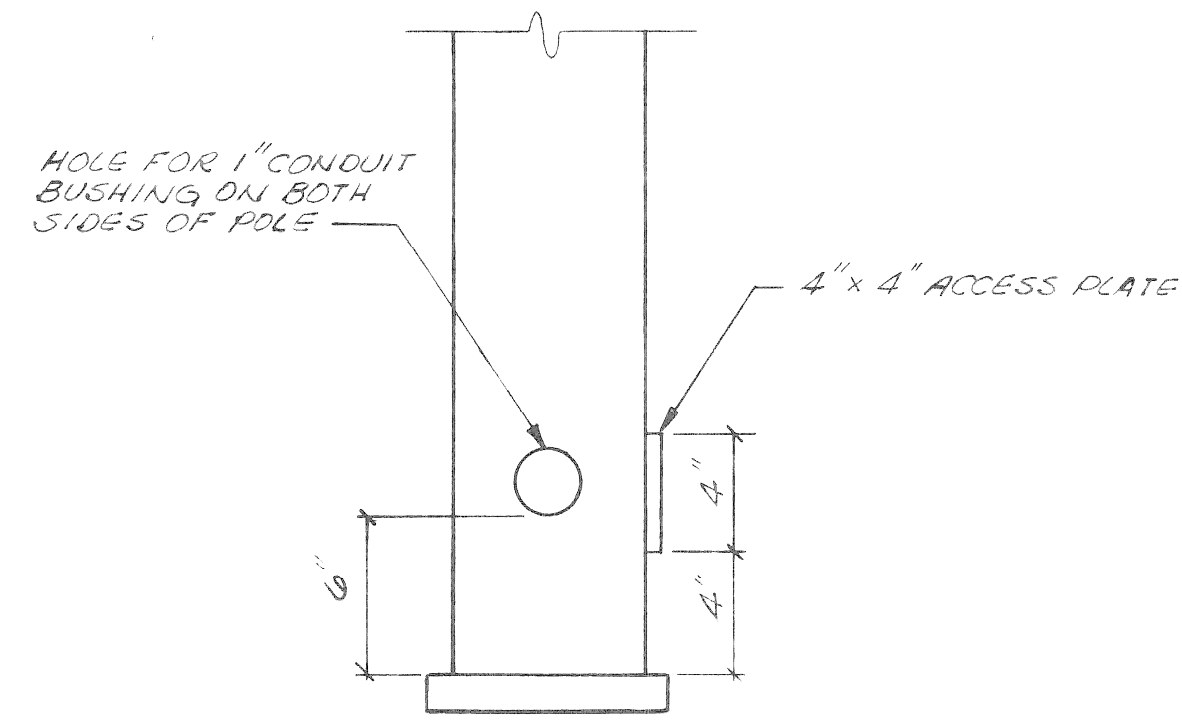

LIGHT POLE ACCESS HOLE DETAIL (D)
N.T.S. (E-2)

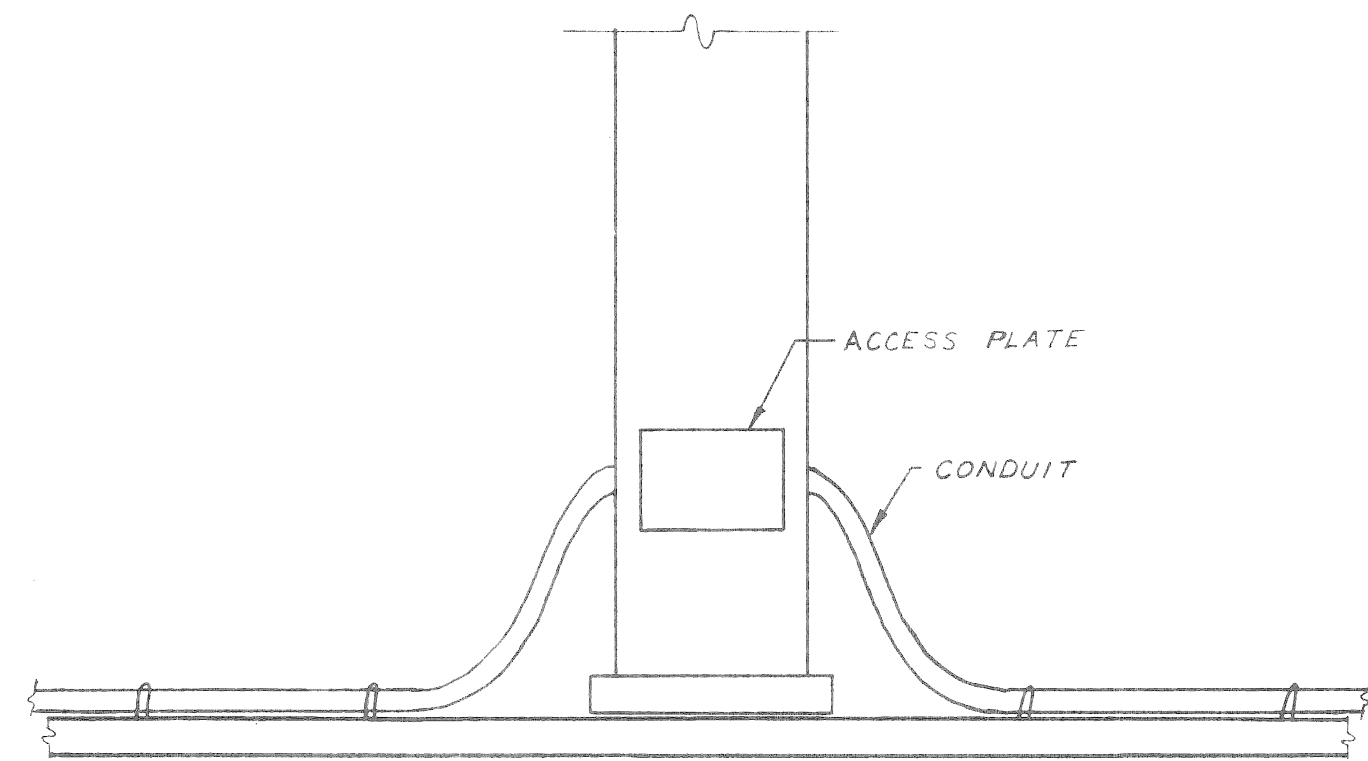

DETAIL A (SIDE VIEW)
N.T.S. (E-1)

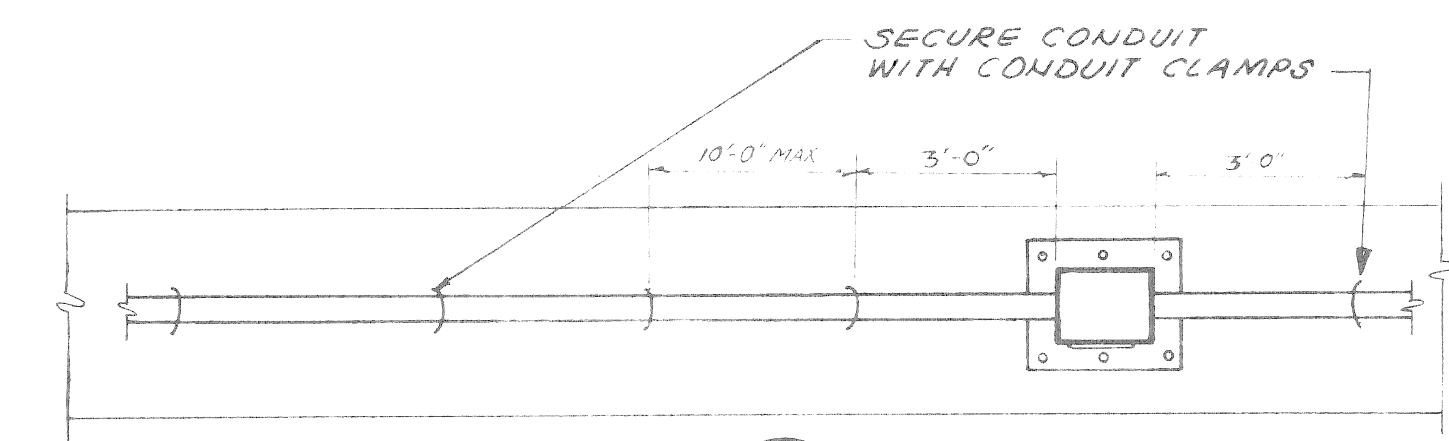

DETAIL B (TOP VIEW)
N.T.S. (E-1)

- NOTES**
1. THE CONDUIT RUN BETWEEN THE LIGHT POLES SHALL BE MOUNTED ON TOP OF THE "I" BEAM.
 2. THE CONDUIT RUN FOR THE LIGHT MOUNTED UNDER THE OVERPASS SHALL BE CONTAINED WITHIN THE PANELS OF THE OVERPASS.
 3. THE WIRE SPLICES SHALL BE MADE WITHIN THE LIGHT POLE ACCESS HOLE AND JUNCTION BOXES.

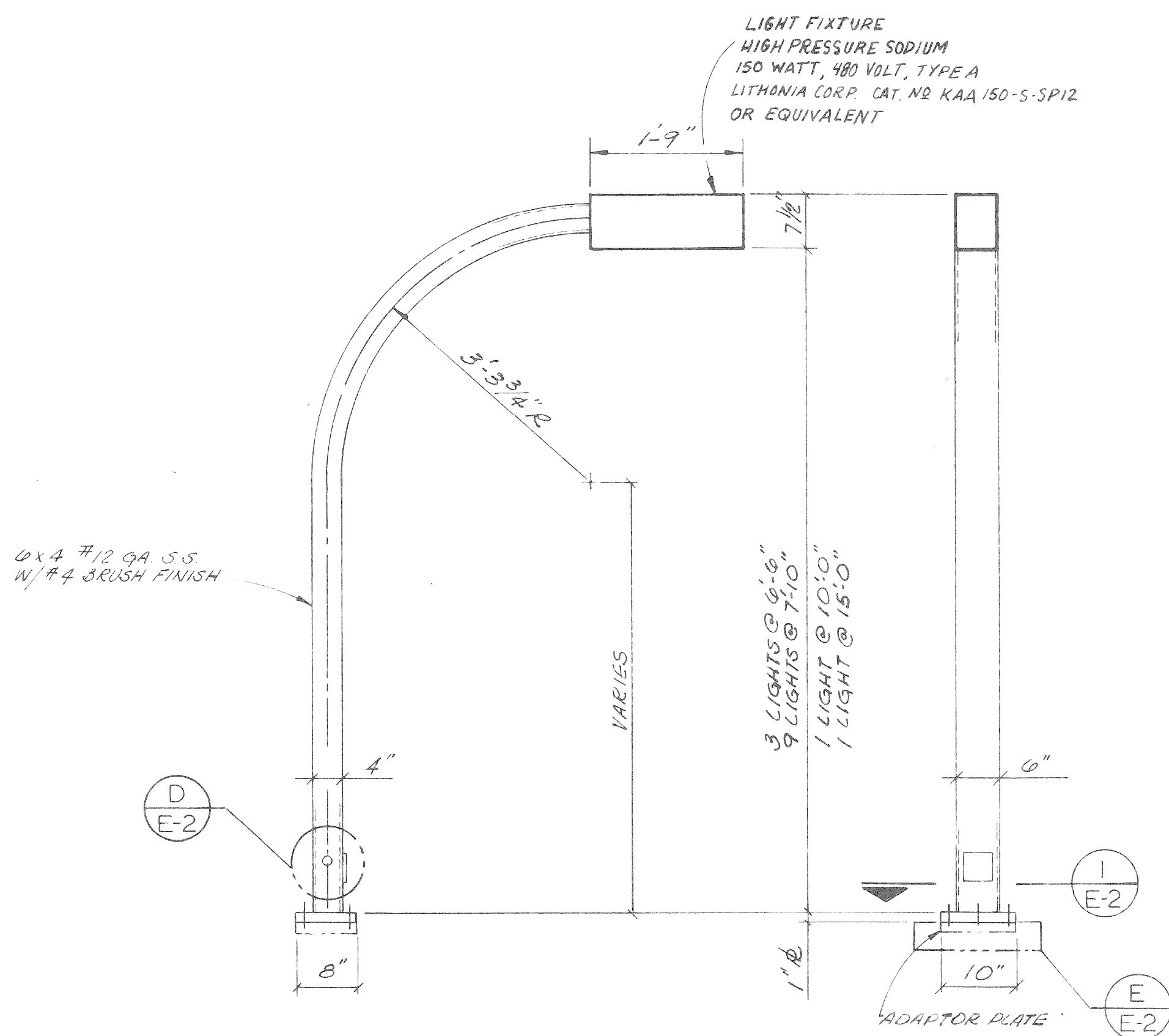

LIGHT FIXTURE & POLE ASSY (C)
SCALE: 3/4" = 1'-0" (E-1)

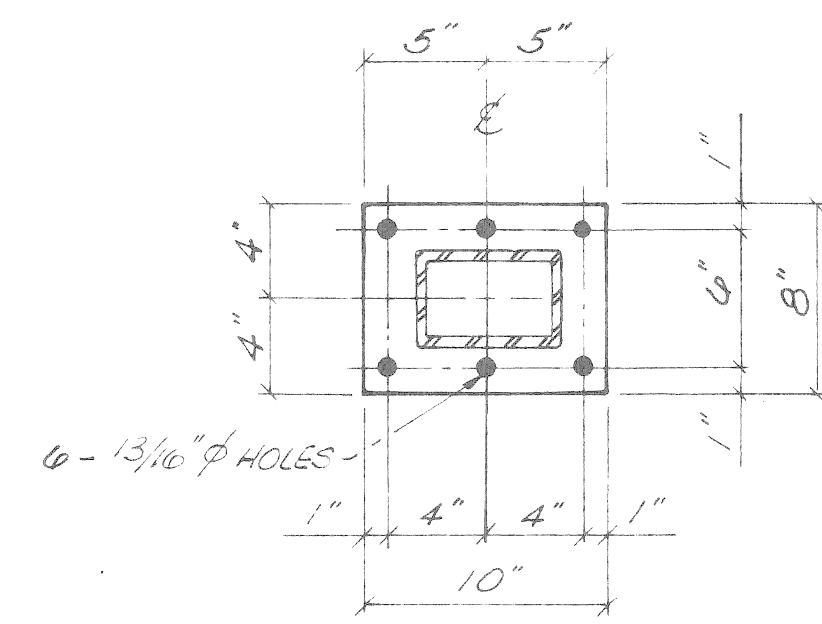

SECTION I
SCALE: 1/2" = 1'-0" (E-2)

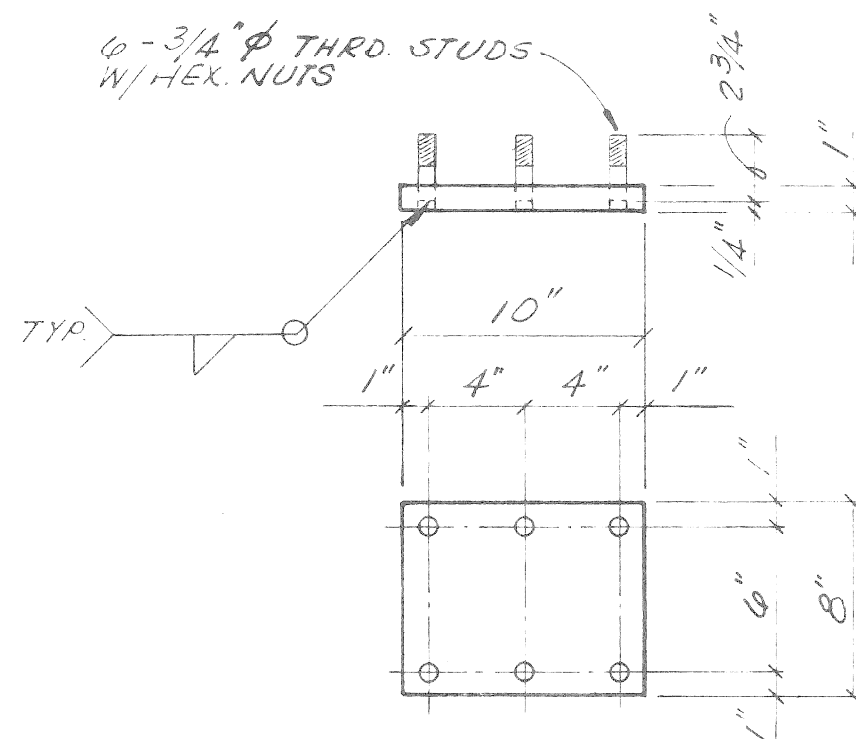

ADAPTOR PLATE DETAIL E
SCALE: 1/2" = 1'-0" (E-2)

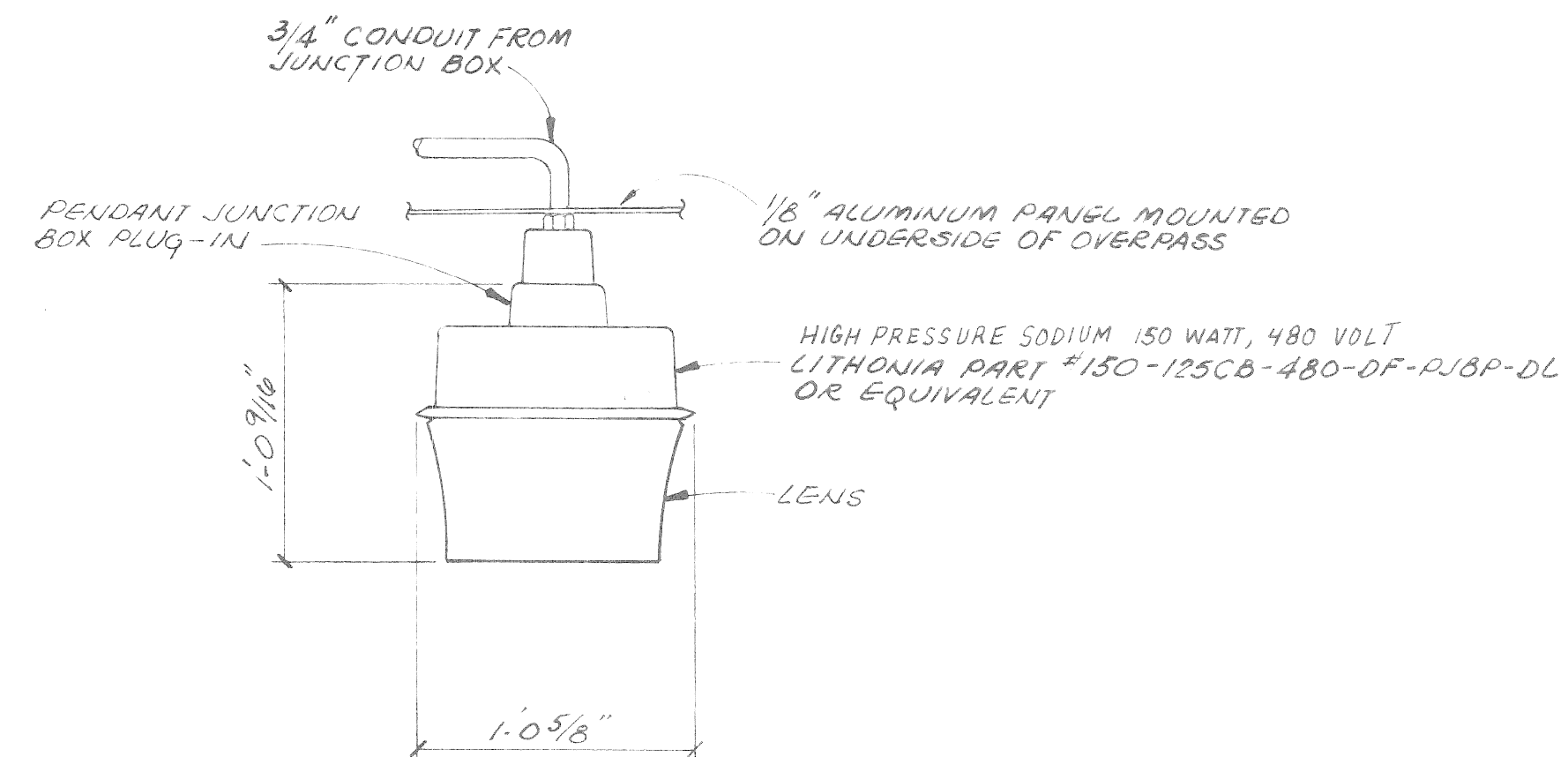

DETAIL F
N.T.S. (E-1)

REVISION	DATE

CITY OF DETROIT

CITY ENGINEERING DEPARTMENT

CITY BRIDGE No. BP-27

Project RANDOLPH STREET PEDESTRIAN BRIDGE

Sheet Title NOTES & DETAILS

MADISON INTERNATIONAL OF MICHIGAN
Engineers, Architects, Planners
1420 Washington Blvd.
Detroit, Michigan 48226

DESIGN BY D.E.K.
DRAWN BY A.P. B.C.J.B.
CHECKED BY P.A.

DATE NOVEMBER, 87
PROJECT NO. 8612
SHEET NO. E-2

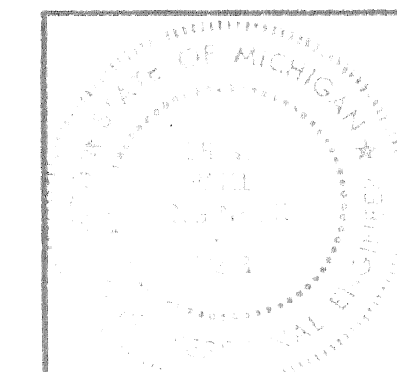

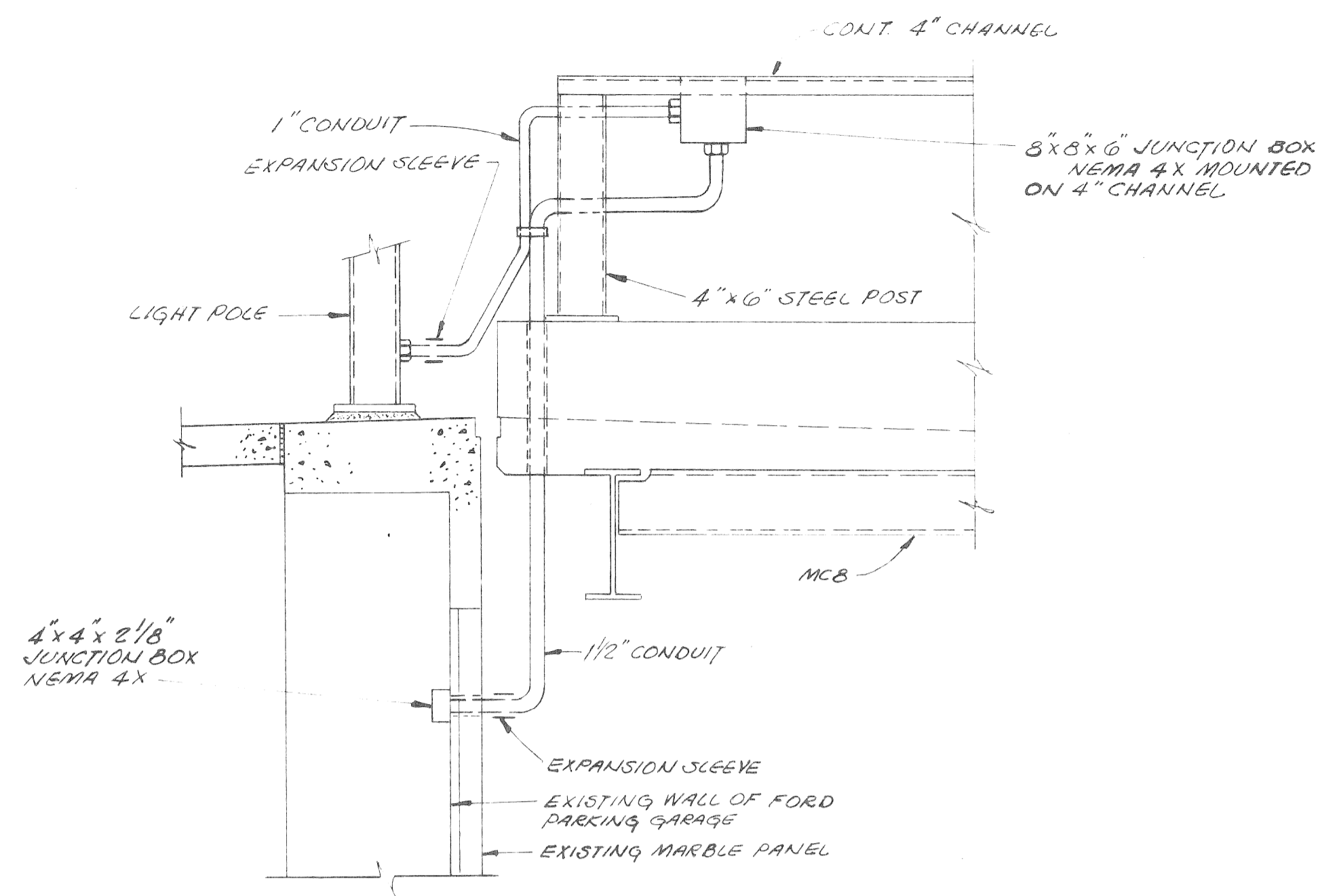

DETAIL 1
SCALE: 1/4" = 1'-0" E-1

where is other details

DATE	REVISION

CITY OF DETROIT
CITY ENGINEERING DEPARTMENT
CITY BRIDGE No. BP-27

Project RANDOLPH STREET PEDESTRIAN BRIDGE
Sheet Title DETAILS

MADISON INTERNATIONAL OF MICHIGAN
Engineers, Architects, Planners
1420 Washington Blvd.
Detroit, Michigan 48226

DESIGN BY D.E. KECK
DRAWN BY C.J.B.
CHECKED BY P.A.

DATE NOVEMBER, 89
PROJECT NO. 8612
SHEET NO. E-3

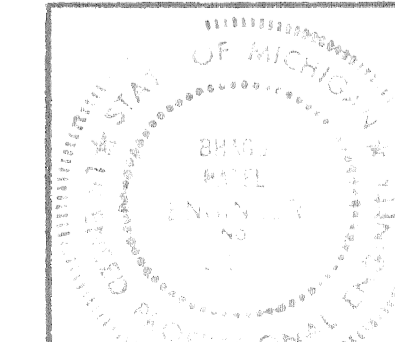

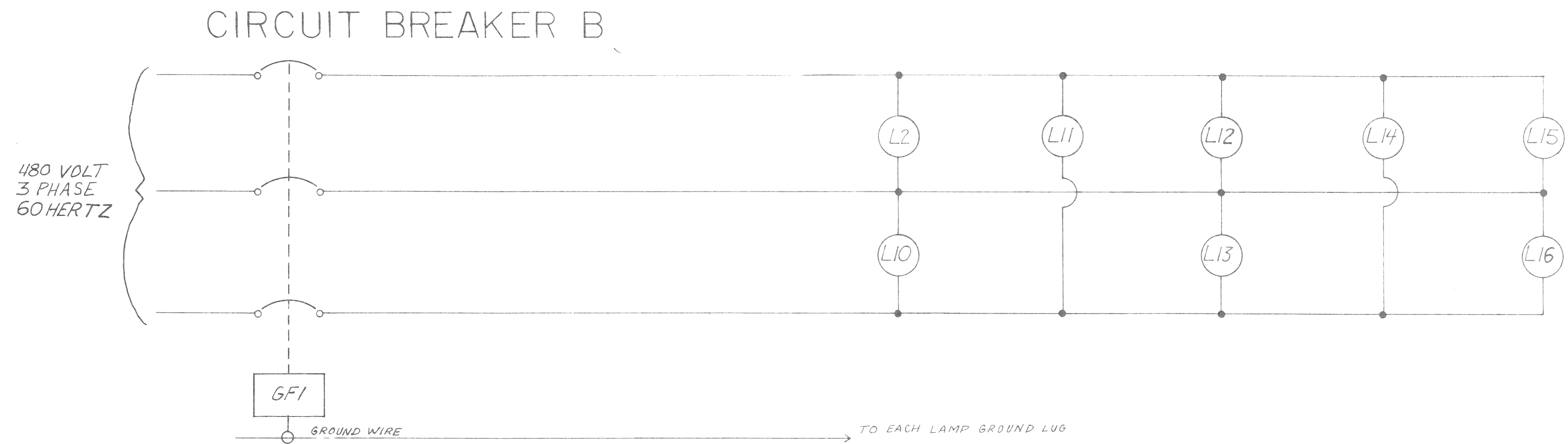
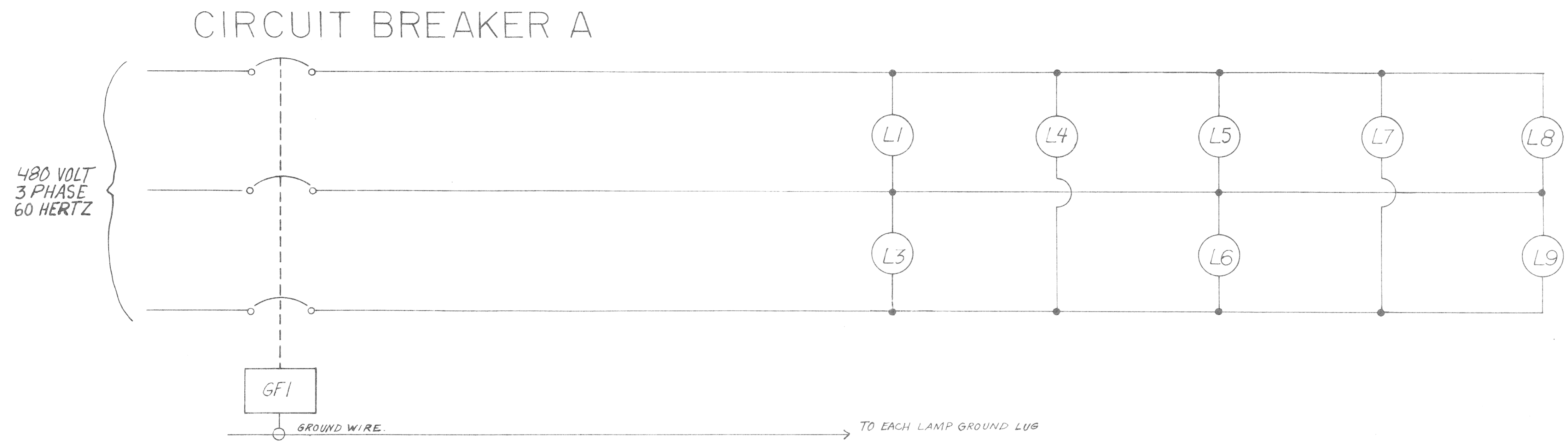

NOTES: GFI = GROUND FAULT INTERRUPT
L1, L2, etc. = LAMP 1, LAMP 2, etc.

REVISION	
DATE	
NO.	

CITY OF DETROIT
CITY ENGINEERING DEPARTMENT
CITY BRIDGE No. BP-27

Project: RANDOLPH STREET PEDESTRIAN OVERPASS
Sheet Title: ELECTRICAL WIRING DIAGRAM

MADISON INTERNATIONAL OF MICHIGAN
Engineers, Architects, Planners
1420 Washington St.
Detroit, Michigan 48226

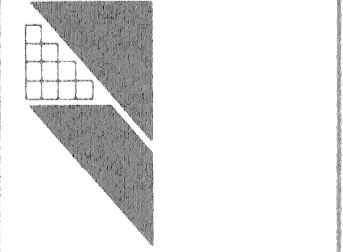

DESIGN BY: D. E. KECK
DRAWN BY: S.V.K.
CHECKED BY: P.A.

DATE: NOVEMBER, 1971
PROJECT NO.: 8612
SHEET NO.: E-4

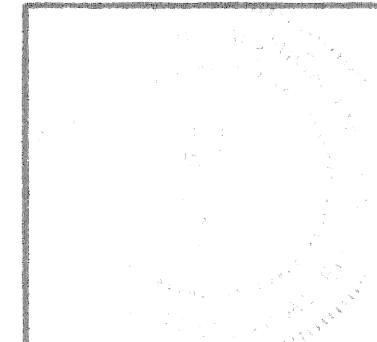

JEFFERSON AVENUE

LEGEND

Existing Elevation
Proposed Elevation

TROLLEY TRACKS

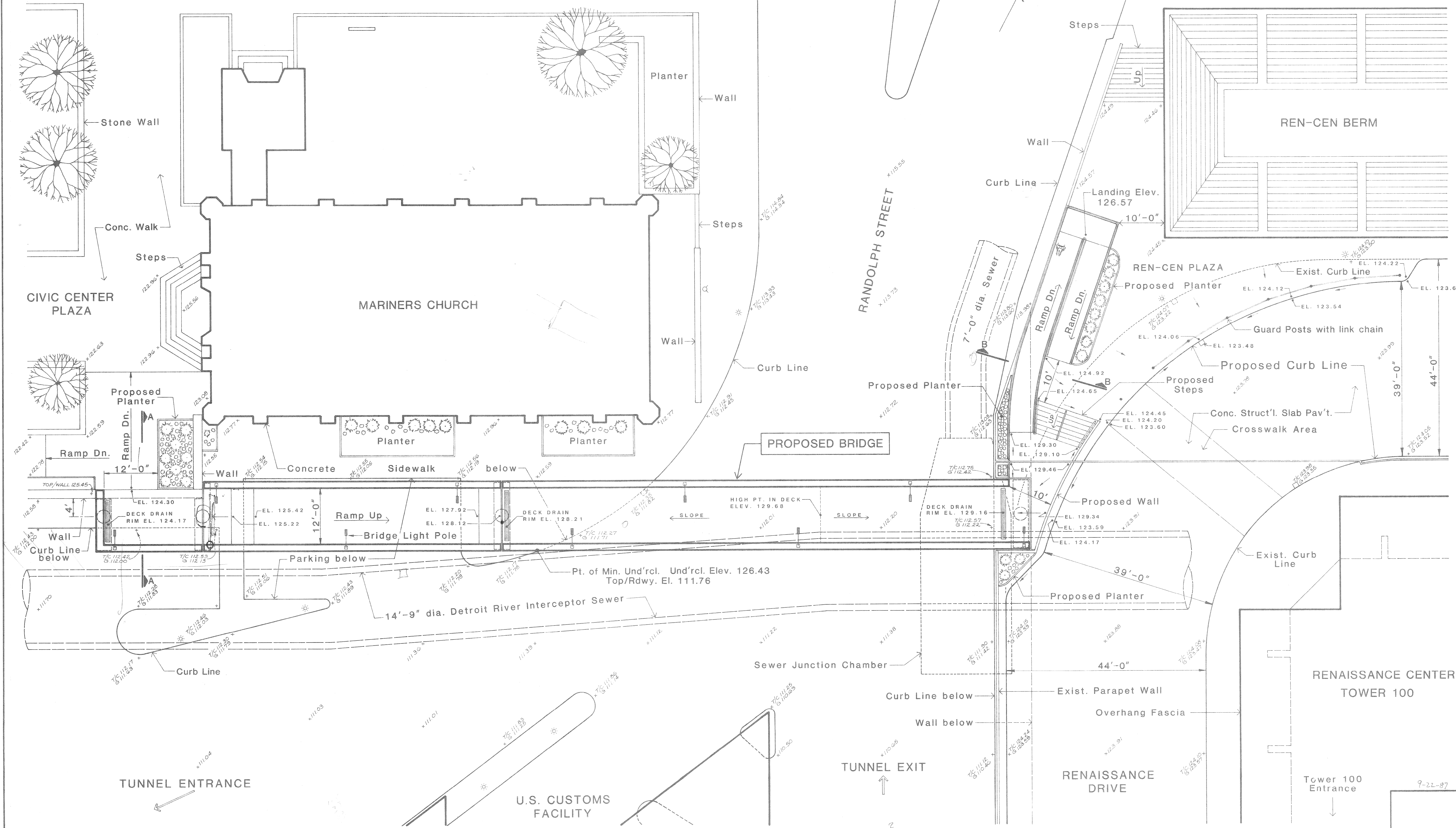

PRELIMINARY PLAN "A"

RANDOLPH STREET PEDESTRIAN BRIDGE

GENERAL PLAN OF STRUCTURE

MADISON INTERNATIONAL OF MICHIGAN
Engineers, Architects, Planners
Detroit, Michigan 48226

DESIGN BY
K.C.H.
DRAWN BY
K.C.H.
CHECKED BY
R.J.C.
DATE
SEPT 11, 1987
PROJECT NO.
8612
SHEET NO.
1 OF 3

PLAN
1" = 10'

81402
81212 10

9-22-87

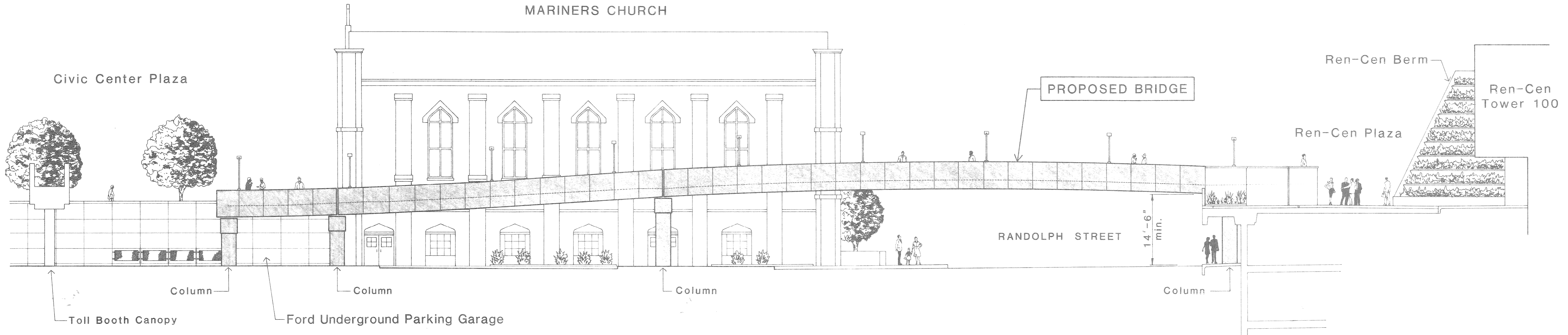

ELEVATION
1" = 10'

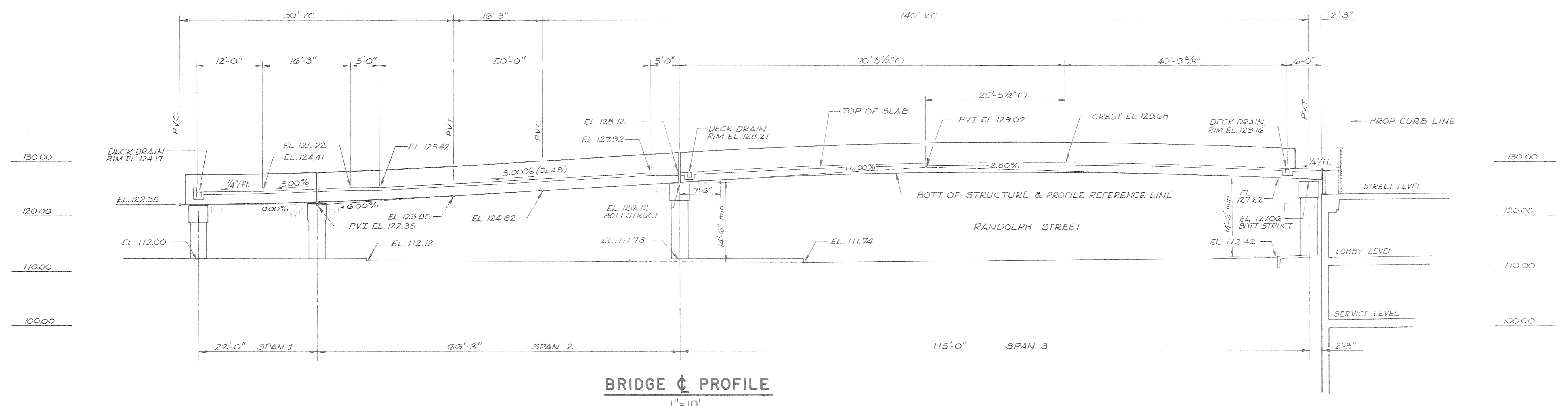

BRIDGE PROFILE
1" = 10'

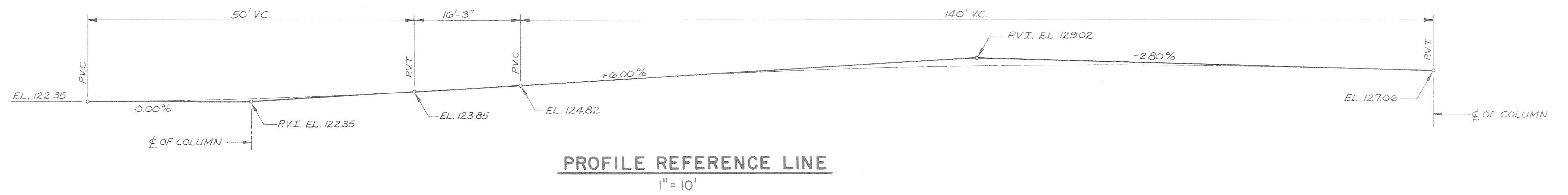

PROFILE REFERENCE LINE
1" = 10'

PRELIMINARY PLAN "A"

Project: RANDOLPH STREET PEDESTRIAN BRIDGE
Sheet Title: GENERAL PROFILE OF STRUCTURE

MADISON INTERNATIONAL OF MICHIGAN
Engineers, Architects, Planners
Detroit, Michigan 48226

DESIGN BY: K.C.H.
DRAWN BY: K.C.H.
CHECKED BY: R.J.C.
DATE: SEPT. 11, 1987
PROJECT NO.: 8612
SHEET NO.: 2 OF 3

9-22-87

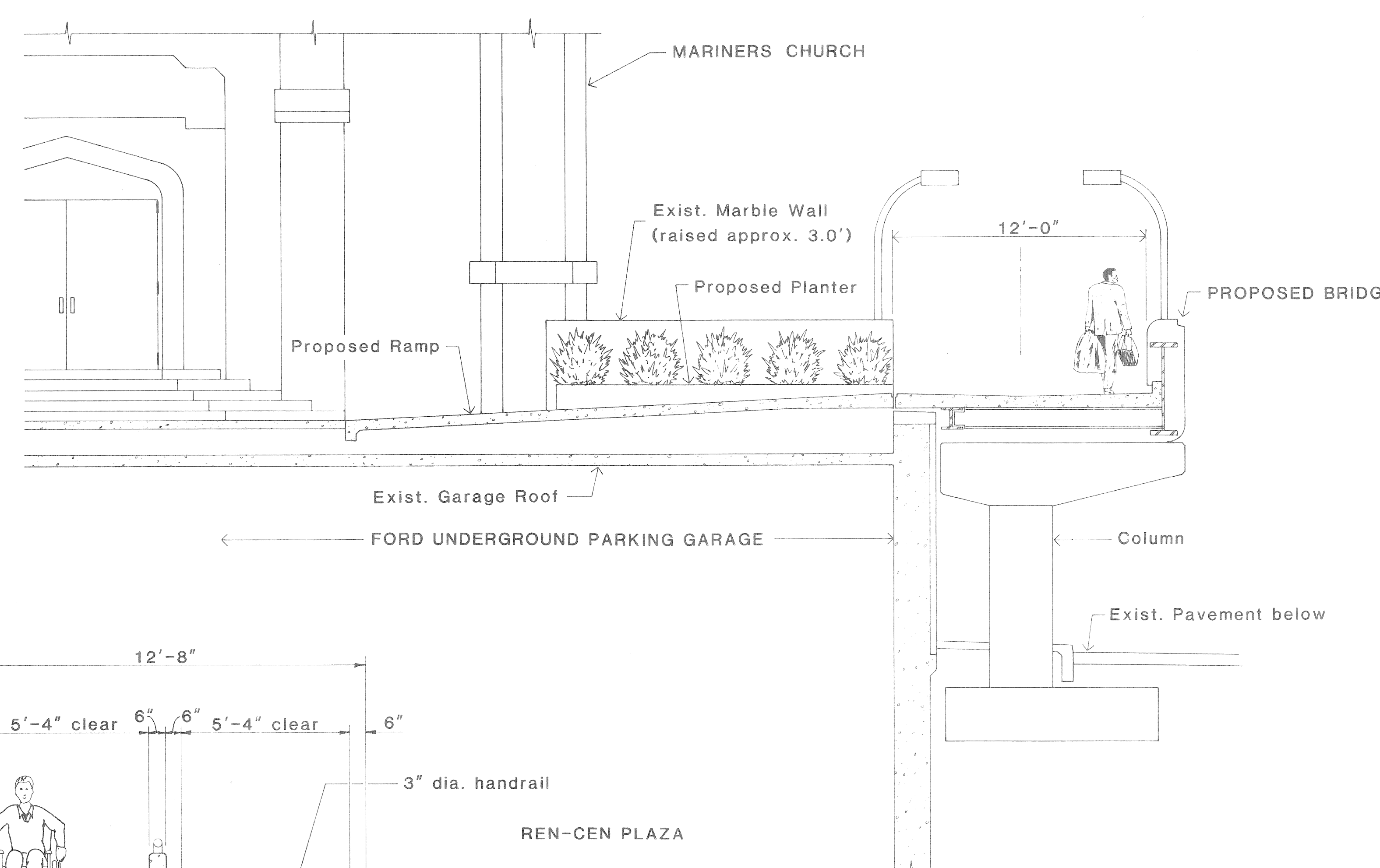

SECTION A-A
1" = 4'

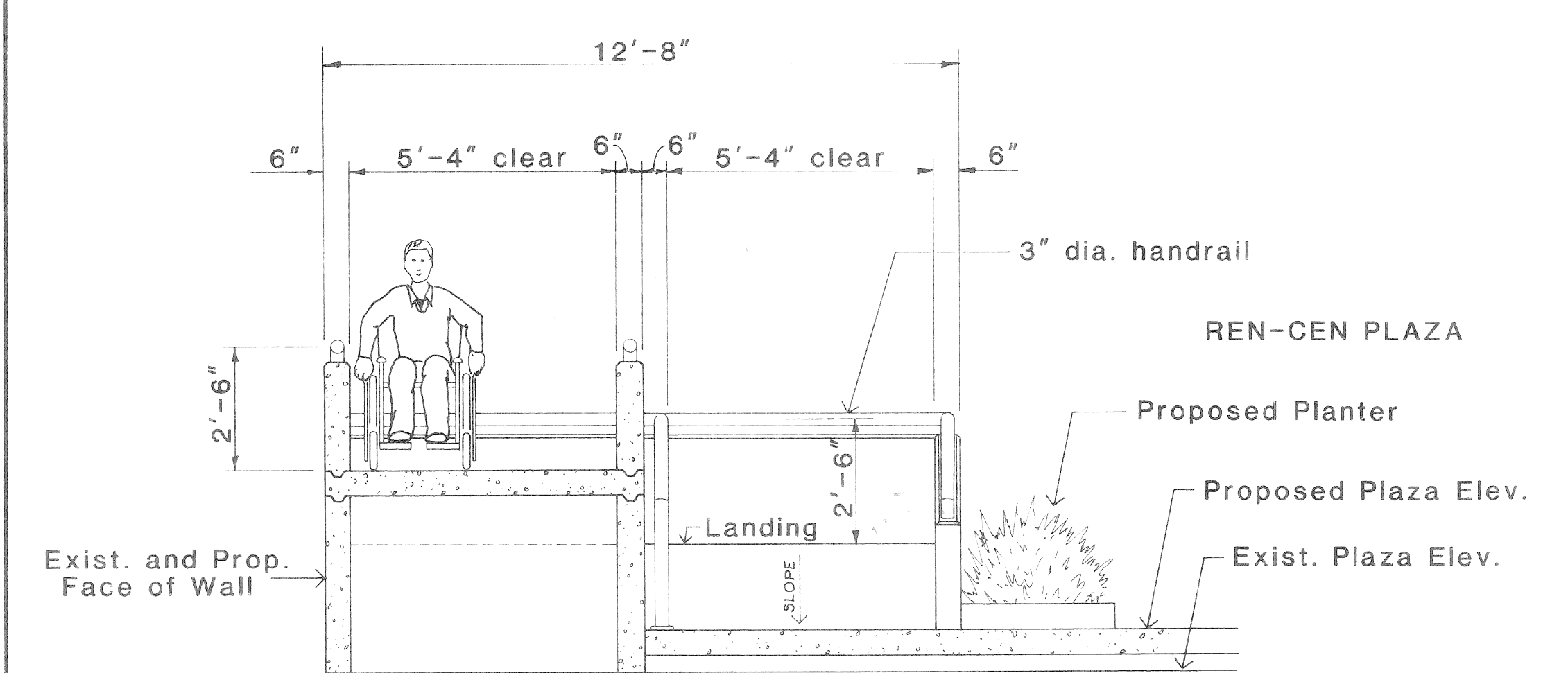

SECTION B-B
3/8" = 1'-0"

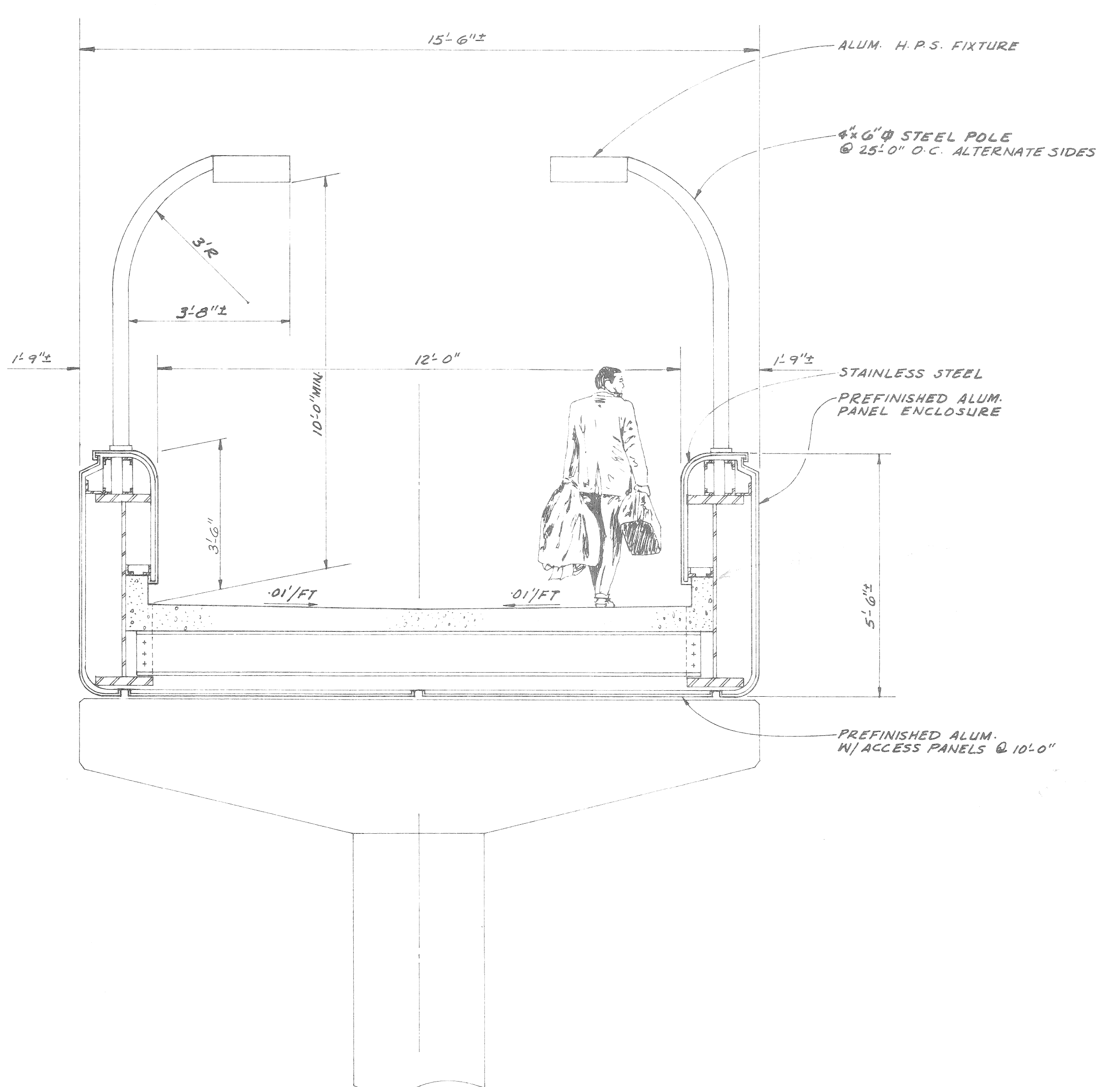

TYPICAL CROSS-SECTION
SCALE: 1/2" = 1'-0"

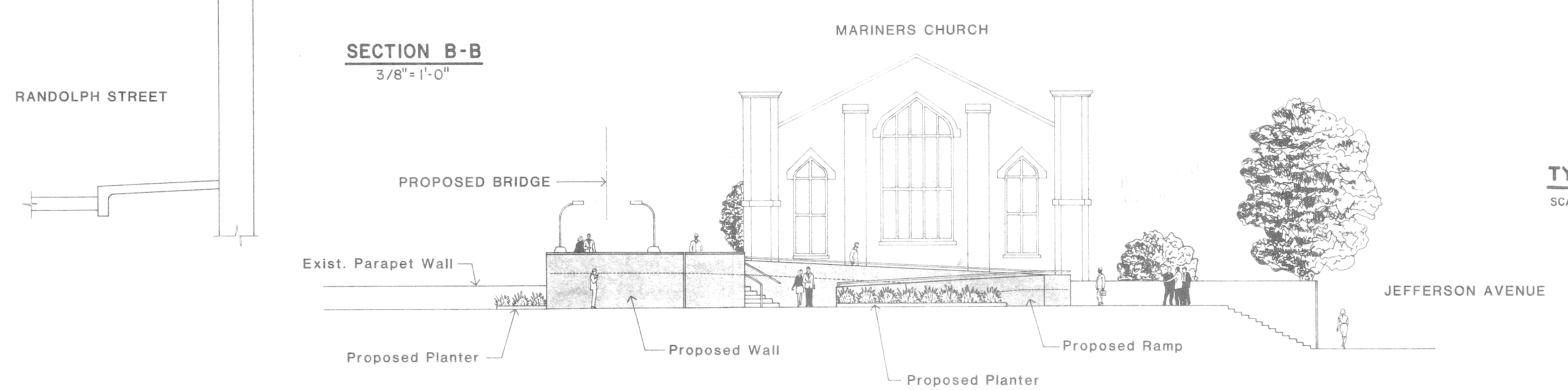

ELEVATION AT REN-CEN PLAZA
1" = 10'

PRELIMINARY PLAN "A"

RANDOLPH STREET
PEDESTRIAN BRIDGE
MISCELLANEOUS SECTIONS

Project
Sheet Title

MADISON MADISON INTERNATIONAL OF MICHIGAN
Engineers, Architects, Planners
Detroit, Michigan 48226

DESIGN BY
K.C.H., SO., D.L.M.
DRAWN BY
K.C.H./P.O.A.
CHECKED BY
R.J.C.

DATE
SEPT. 11, 1987
PROJECT NO.
8612
SHEET NO.
3 OF 3

9-22-87

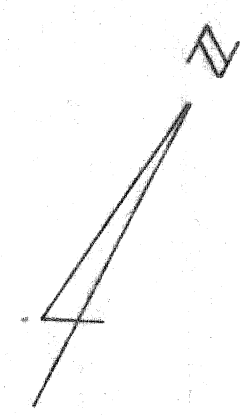
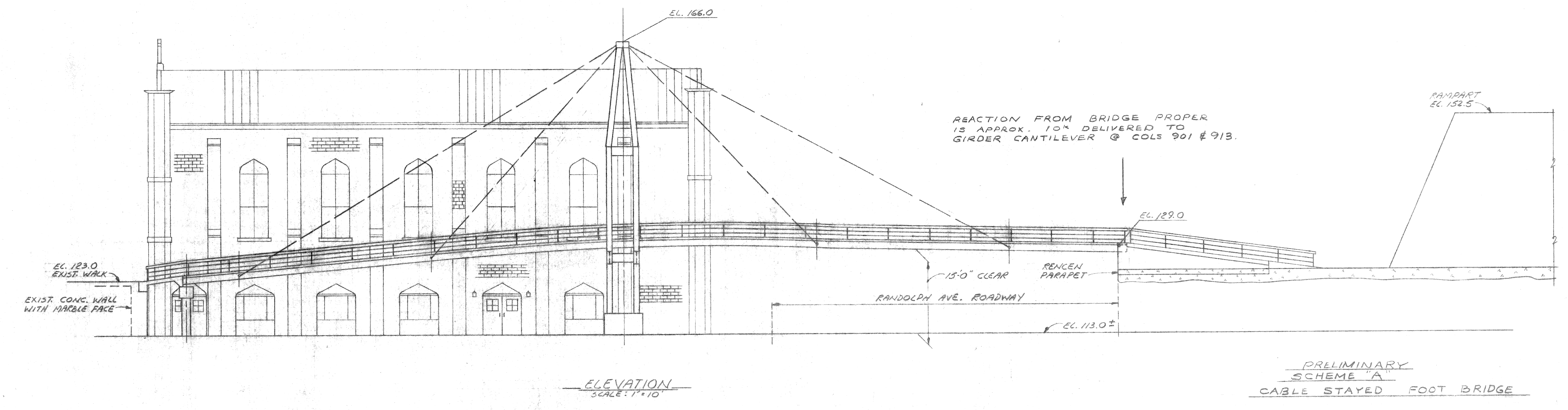
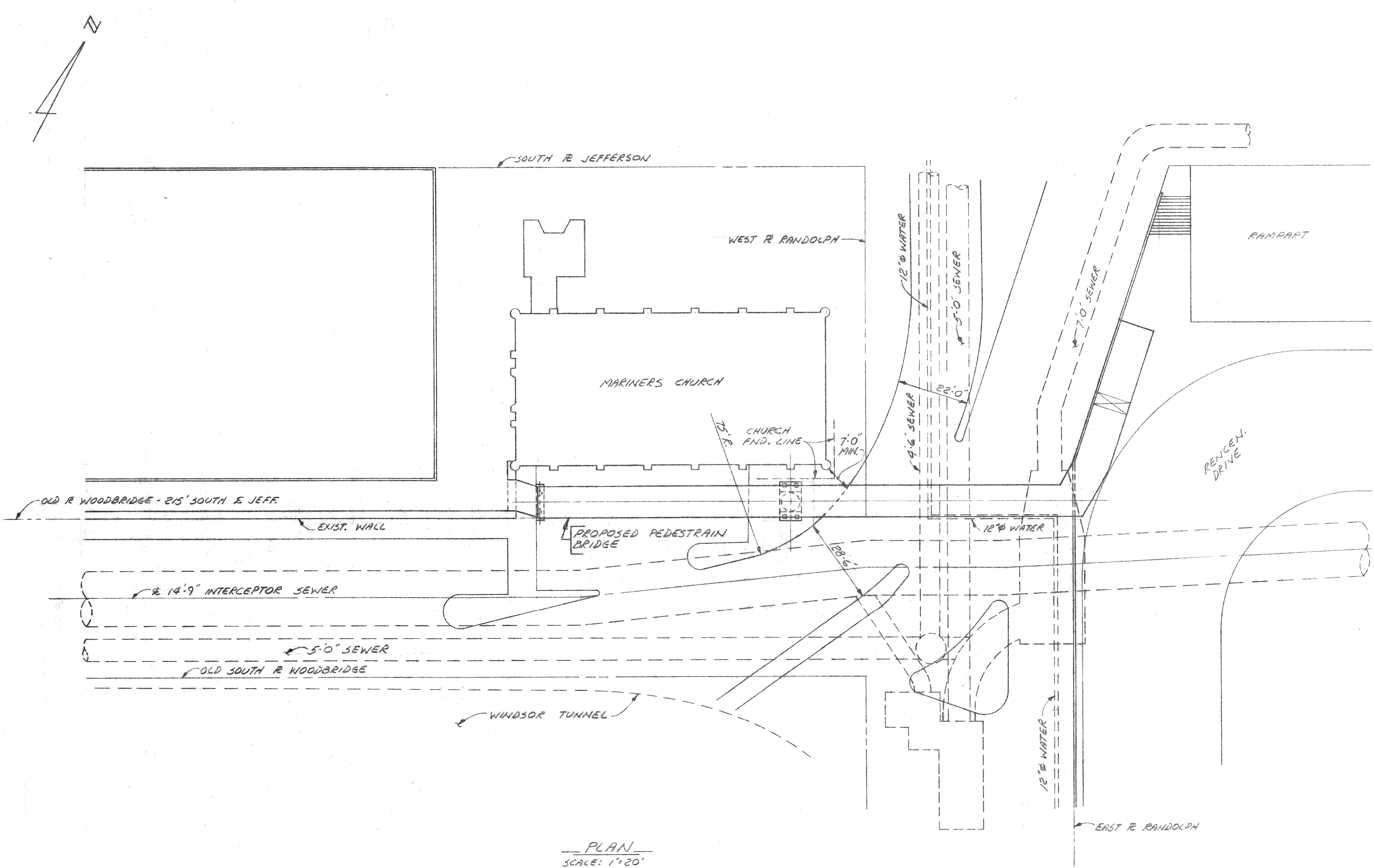

REVISED	DATE	BY
A		
B		
C		
D		
E		

DESIGNED BY: T.M.
 DRAWN BY: A.G.
 CHECKED BY:
 APPROVED:

CITY OF DETROIT
 ENVIRONMENTAL PROTECTION AND MAINTENANCE DEPARTMENT
 CITY ENGINEERING DIVISION
 FOR

MARINER RENCEN FOOT BRIDGE
 PRELIMINARY SCHEME "A"

SITE PLAN AND ELEVATION

A.O. —
 CONTRACT NO. —
 DRAWING NO. —
 SHEET 1 OF 2
 DATE 8-15-79

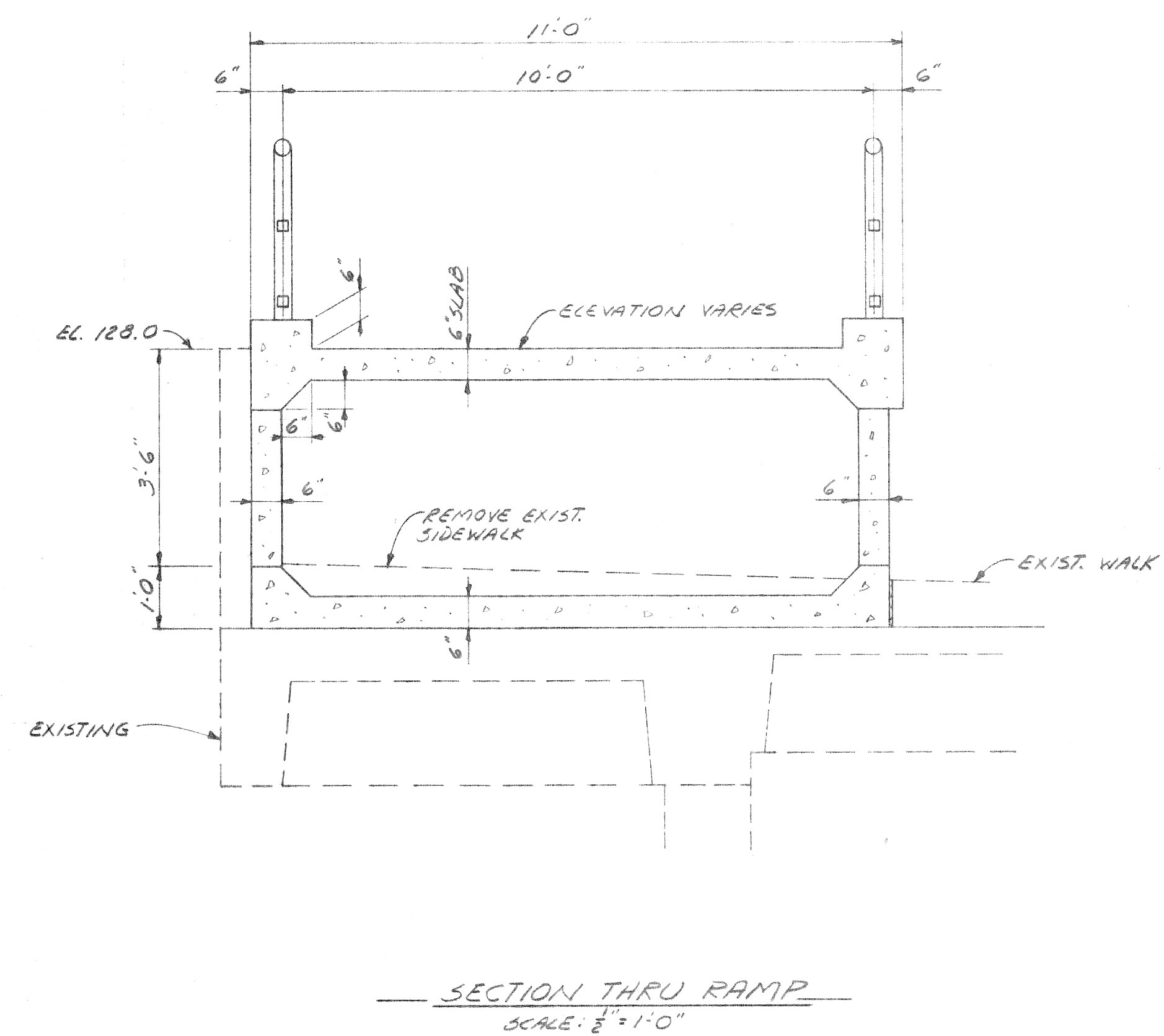
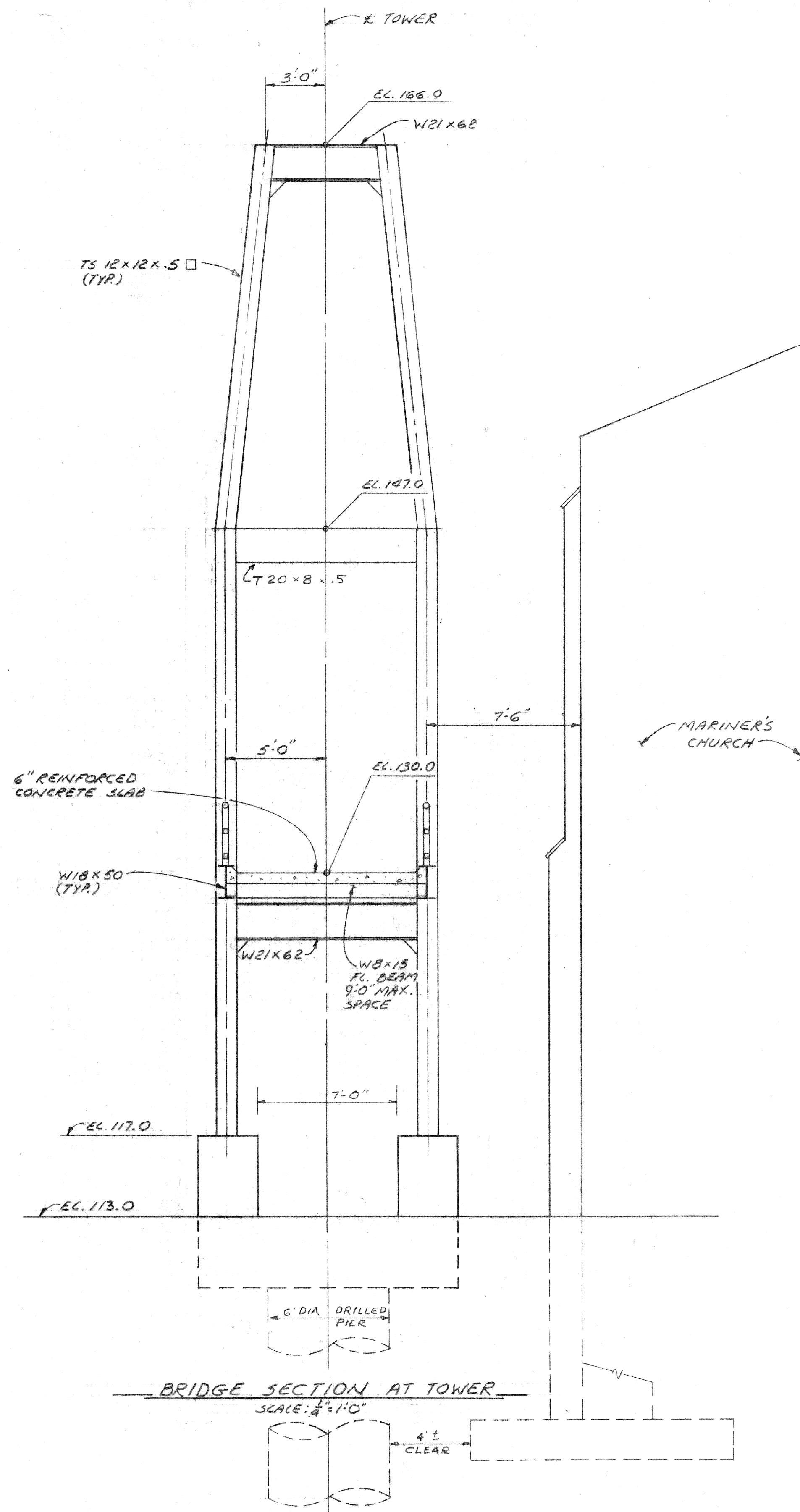

PRELIMINARY
SCHEME "A"
CABLE-STAYED FOOT BRIDGE

REVISED	DATE	BY

DESIGNED BY T.M.
DRAWN BY A.G.
CHECKED BY
APPROVED BY

CITY OF DETROIT
ENVIRONMENTAL PROTECTION AND MAINTENANCE DEPARTMENT
CITY ENGINEERING DIVISION
FOR

MARINER RENOVATION FOOT BRIDGE
PRELIMINARY SCHEME "A"

SECTIONS

A.O. —
CONTRACT NO. —
DRAWING NO. —
SHEET 2 OF 2
DATE 8-15-79

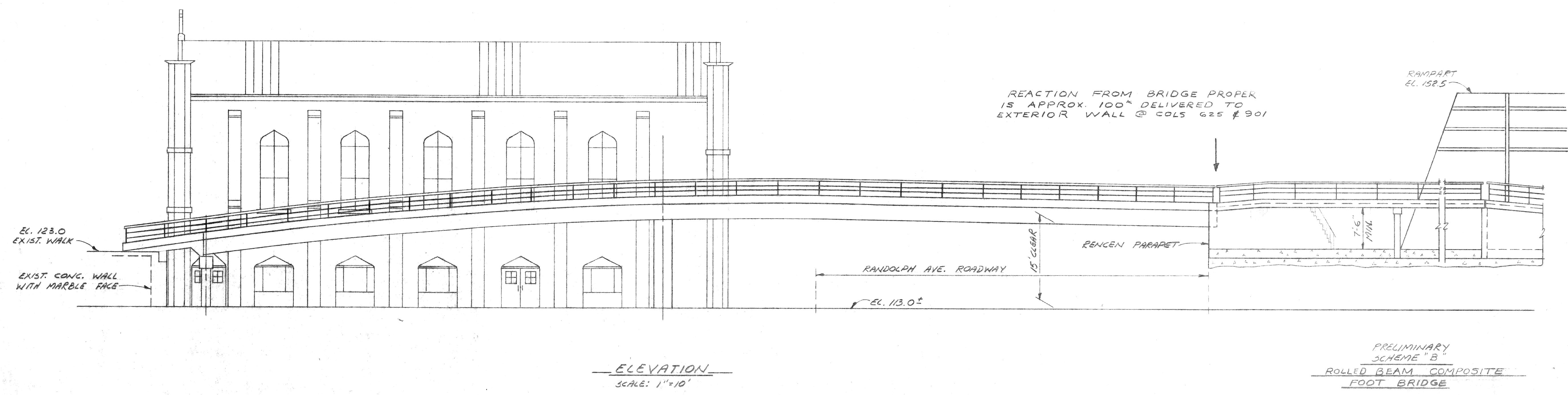
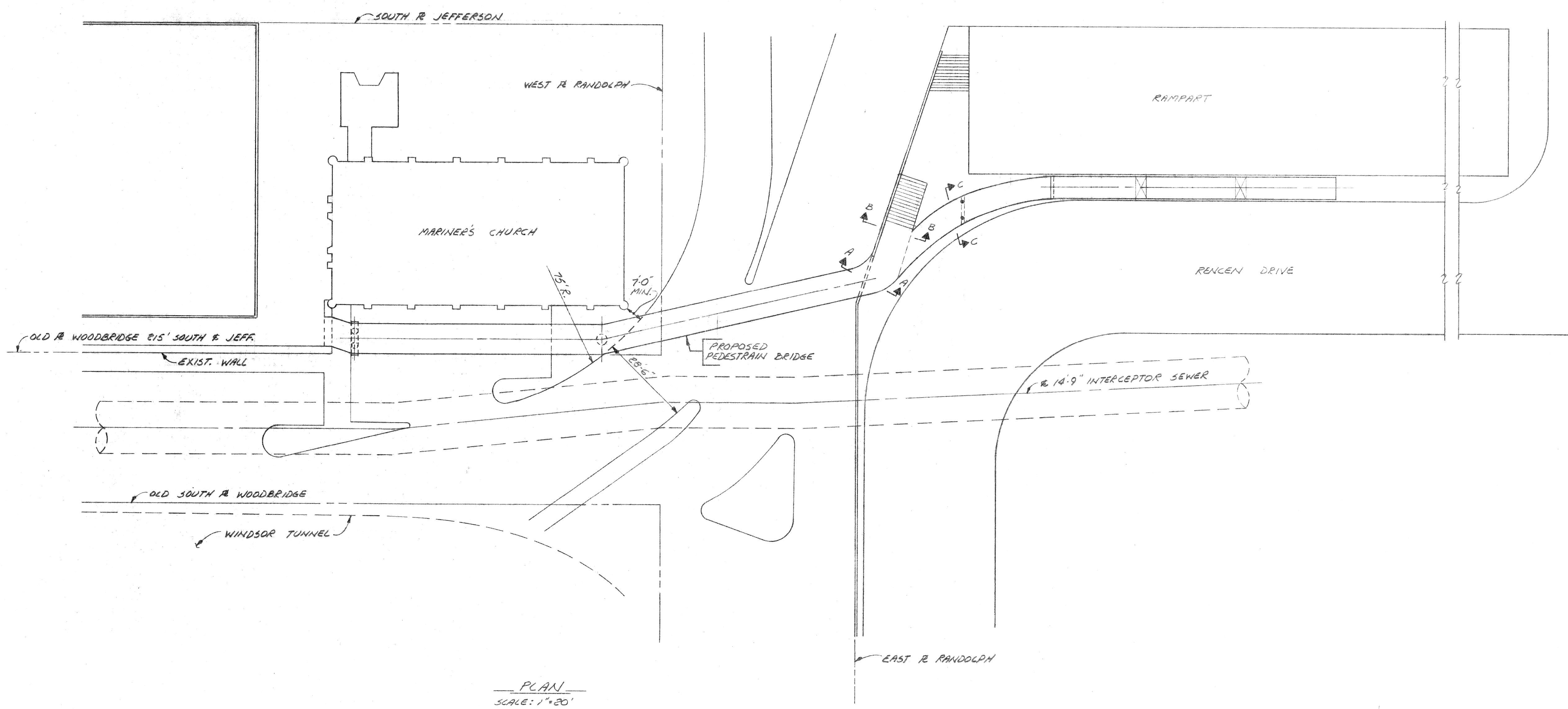
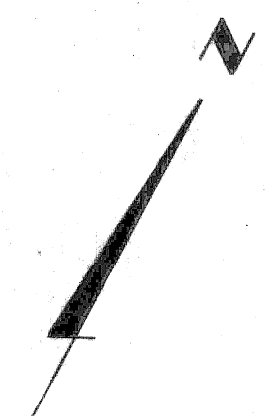

DRN CK'D. AP. YD. DATE

REVISIONS

DESIGNED BY T.M. - M.C.

DRAWN BY A.G.

CHECKED BY

APPROVED:

CITY OF DETROIT

ENVIRONMENTAL PROTECTION AND MAINTENANCE DEPARTMENT

CITY ENGINEERING DIVISION

FOR

MARINER RENCEN FOOT BRIDGE

PRELIMINARY SCHEME "B"

SITE PLAN AND ELEVATION

A.O. _____

CONTRACT NO. _____

DRAWING NO. _____

SHEET 1 OF 2

DATE 8-15-79

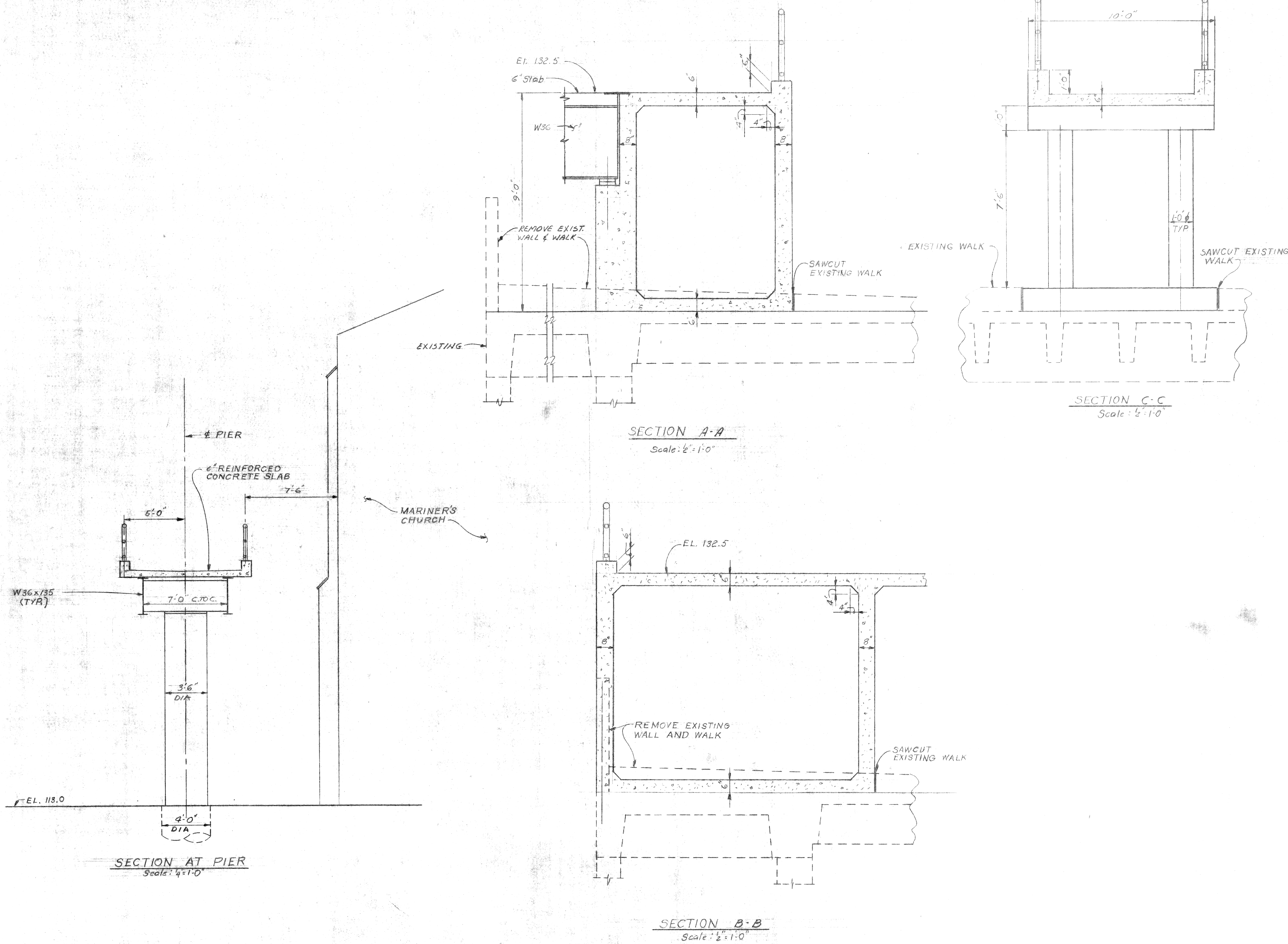

REVISED	DATE	BY	CHK'D	AP'D	DATE

DESIGNED BY T.M.-M.C.
 DRAWN BY A.G.
 CHECKED BY
 APPROVED:

CITY OF DETROIT
 ENVIRONMENTAL PROTECTION AND MAINTENANCE DEPARTMENT
 CITY ENGINEERING DIVISION
 FOR

MARINER RENOVATION FOOT BRIDGE
 PRELIMINARY SCHEME B4C

SECTIONS

PRELIMINARY SCHEME B4C
 ROLLED BEAM COMPOSITE FOOT BRIDGE

A.O. 82-22-01
 CONTRACT NO. —
 DRAWING NO.
 SHEET 2 OF 2
 DATE 10-82

JEFFERSON AVE. 210 FEET WIDE

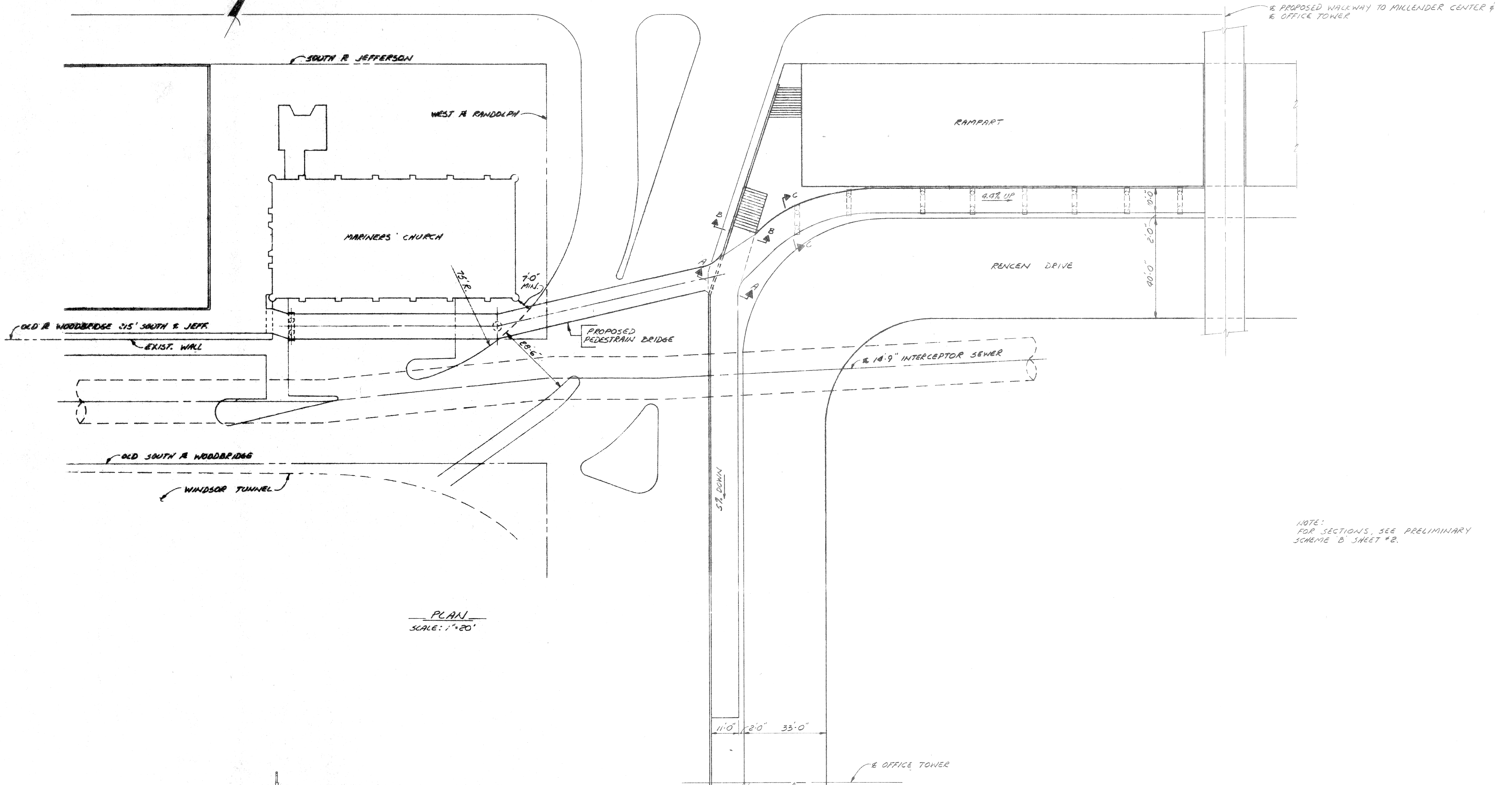
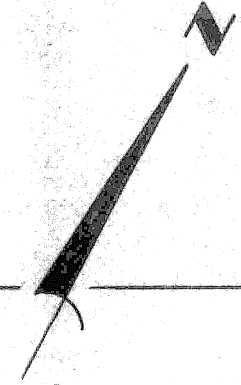

NOTE: FOR SECTIONS, SEE PRELIMINARY SCHEME 'B' SHEET #2.

PLAN SCALE: 1"=20'

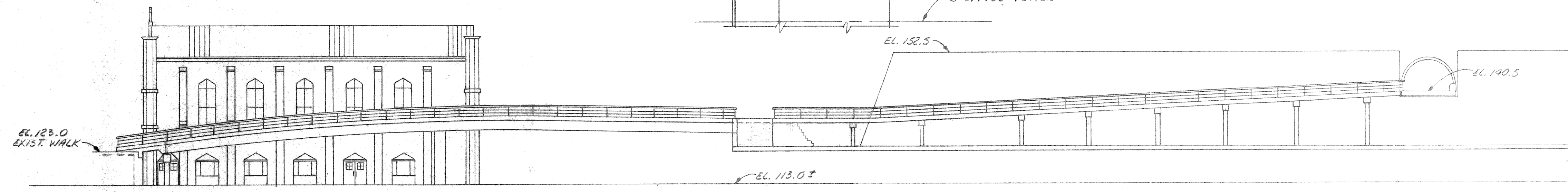

ELEVATION SCALE: 1"=20'

no.	date	by	checked	approved

designed by
 drawn by A.G.
 checked by
 approved:

CITY OF DETROIT
 department of public works
 city engineering division

for
 MARINER RENCEN FOOT BRIDGE
 PRELIMINARY SCHEME 'C'

SITE PLAN AND ELEVATION

a.o. 82-22-01
 contract no.
 sheet / of /
 drawing no.
 date 10-82