

EXISTING TOP OF SLAB ELEVATIONS  
1/8" = 1'-0"

EXISTING SIDEWALK ELEVATIONS  
1/8" = 1'-0"

DESCRIPTION	DR	CHK	DATE	BY	CHECKED BY	APPROVED
PLAN	PS	AF				<i>Carl C Howard</i>
GRADE	PS	PS				
ESTIMATE						
FINAL	****	****				

CITY OF DETROIT  
CITY ENGINEERING DEPARTMENT  
STRUCTURAL BUREAU  
FOR  
MICHIGAN DEPARTMENT OF TRANSPORTATION

SPINOZA DRIVE BRIDGE  
BW-270  
EXISTING SLAB AND SIDEWALK ELEVATIONS

SHEET 5-9 A OF SHEETS
CONTRACT NO.
ASSIGNMENT NO.
DATE 03/94

FEB 19 1996

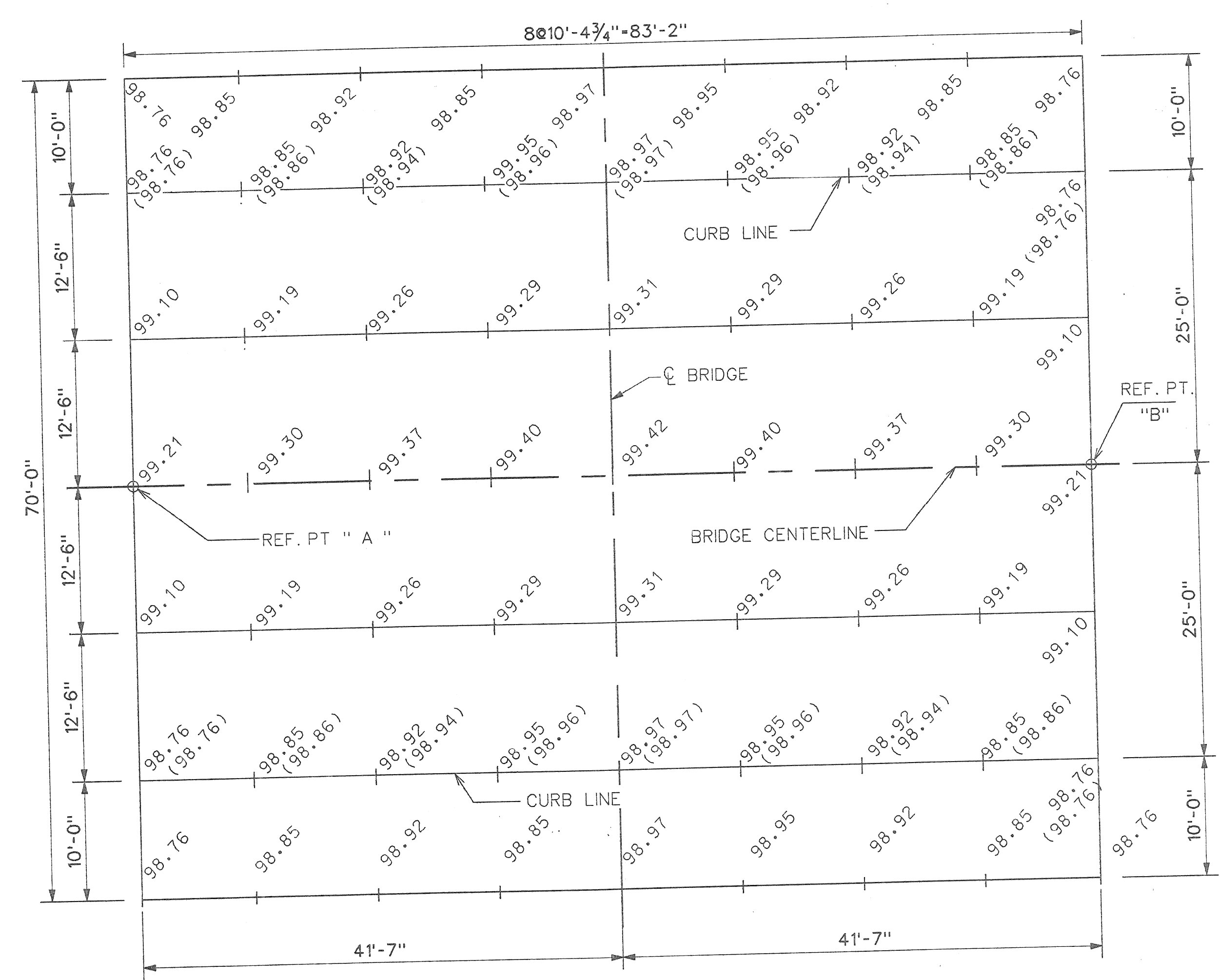

PROPOSED TOP OF DECK SLAB ELEVATIONS  
1/8" = 1'-0"



PROPOSED SIDEWALK ELEVATIONS  
1/8" = 1'-0"

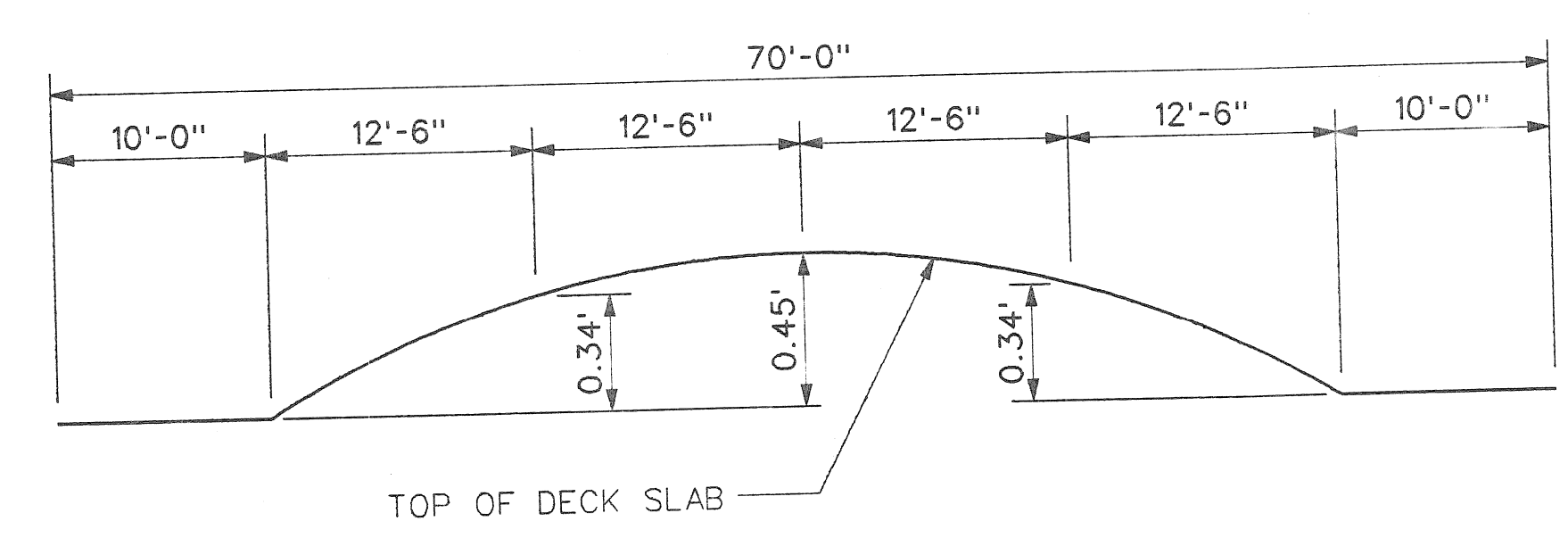

TYPICAL SECTION FOR TOP OF DECK SLAB  
NO SCALE

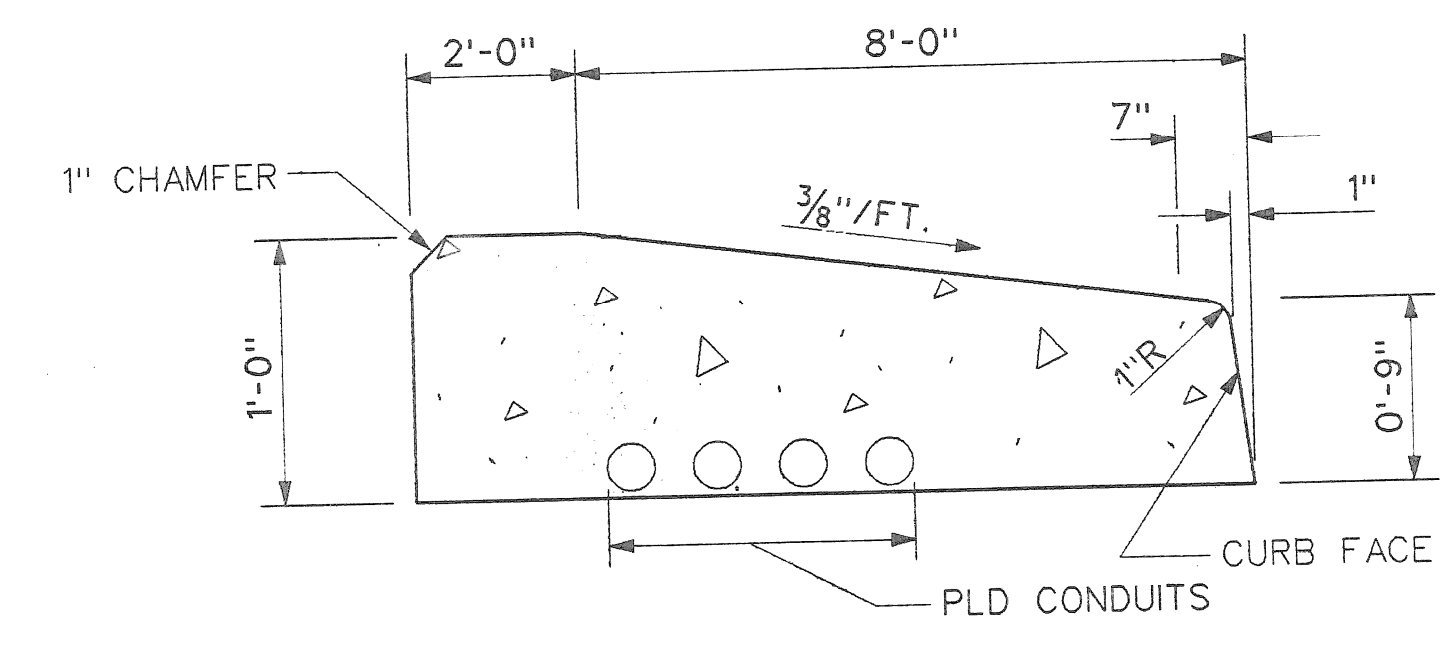

TYPICAL SIDEWALK SECTION  
NO SCALE

- NOTES :
1. ALL ELEVATIONS ARE BASED ON CITY OF DETROIT DATUM.
  2. SIDEWALK POUR SHALL NOT BE CAST UNTIL SLAB CONCRETE HAS ATTAINED AT LEAST 75% OF ITS DESIGN STRENGTH.
  3. FOR SURVEY BENCH MARK LOCATIONS & ELEVATIONS, SEE SHEET NO. S-3.
  4. SLAB & SIDEWALK ELEVATIONS ARE BASED ON THE CONDITIONS THAT ALL CONCRETE BEAMS HAVE BEEN ERECTED, BUT NO OTHER LOADS ARE APPLIED. THESE ELEVATIONS INCLUDE ALLOWANCES FOR DEFLECTION DUE TO FORMS AND STEEL REINFORCEMENT, DECK CONCRETE AND BARRIERS.
  5. SCREED ELEVATIONS ARE BASED ON THE CONDITION THAT NO SLAB CONCRETE HAS BEEN CAST AND THAT FORMWORK AND STEEL REINFORCEMENT ARE IN PLACE.
  6. TRANSVERSE STRIKE OF FINISHING MACHINE IS TO BE USED IN PLACING DECK CONCRETE.
  7. SCREED RAILS FOR FINISHING CONCRETE SHALL BE LOCATED OVER FASCIA BEAMS.
  8. SCREED ELEVATIONS ARE IN PARENTHESIS THUS
  9. TRANSVERSE SIDEWALK CONTRACTION JOINTS TO BE AT 8-FT. INTERVALS OR AS DIRECTED BY THE ENGINEER.

JOB NO. 36916A

DESCRIPTION	DATE	BY	CHECKED BY	APPROVED BY
PLAN		N.W., K.M.		
GRADE		P.S., N.W.		
ESTIMATE				
FINAL				

CITY OF DETROIT  
CITY ENGINEERING DIVISION - D.P.W.  
BUREAU OF STREETS AND HIGHWAYS

SPINOZA DRIVE BRIDGE OVER ROUGE RIVER (BW-270)  
PROPOSED DECK SLAB AND SIDEWALK ELEVATIONS

SHEET S-10 OF SHEETS
CONTRACT NO.
ASSIGNMENT NO. 93-22-16
DATE APR. 1996



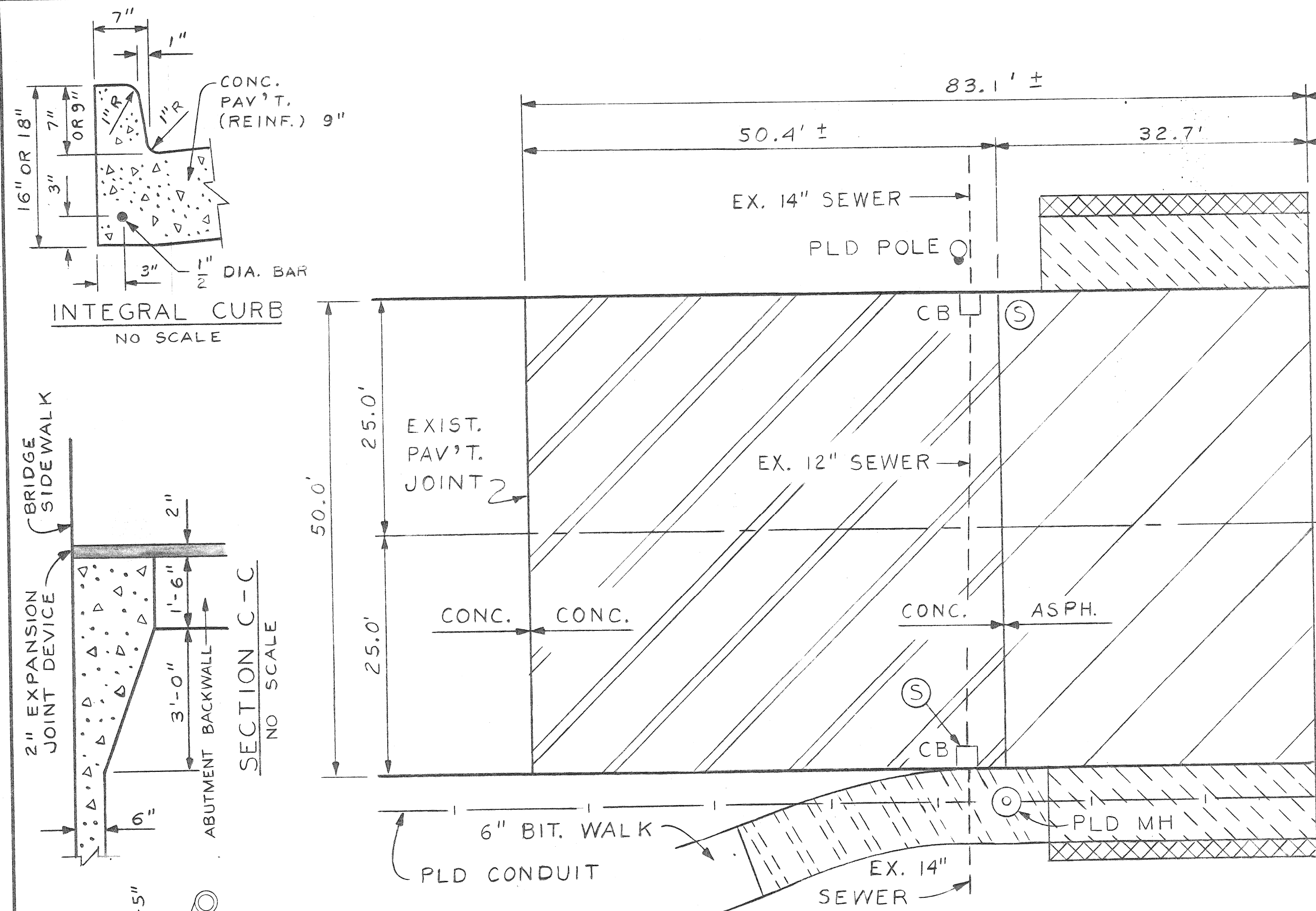

PAY QUANTITIES		
ITEM	QUANTITY	PAY UNIT
REMOVING PAVEMENT	950	SYD
REMOVING SIDEWALK	130	SYD
ABANDONING DRAINAGE STRUCTURES	2	EACH
EARTH EXCAVATION	10	CYD
EMBANKMENT (LM)	20	CYD
SUBGRADE UNDERCUTTING, TYPE II	10	CYD

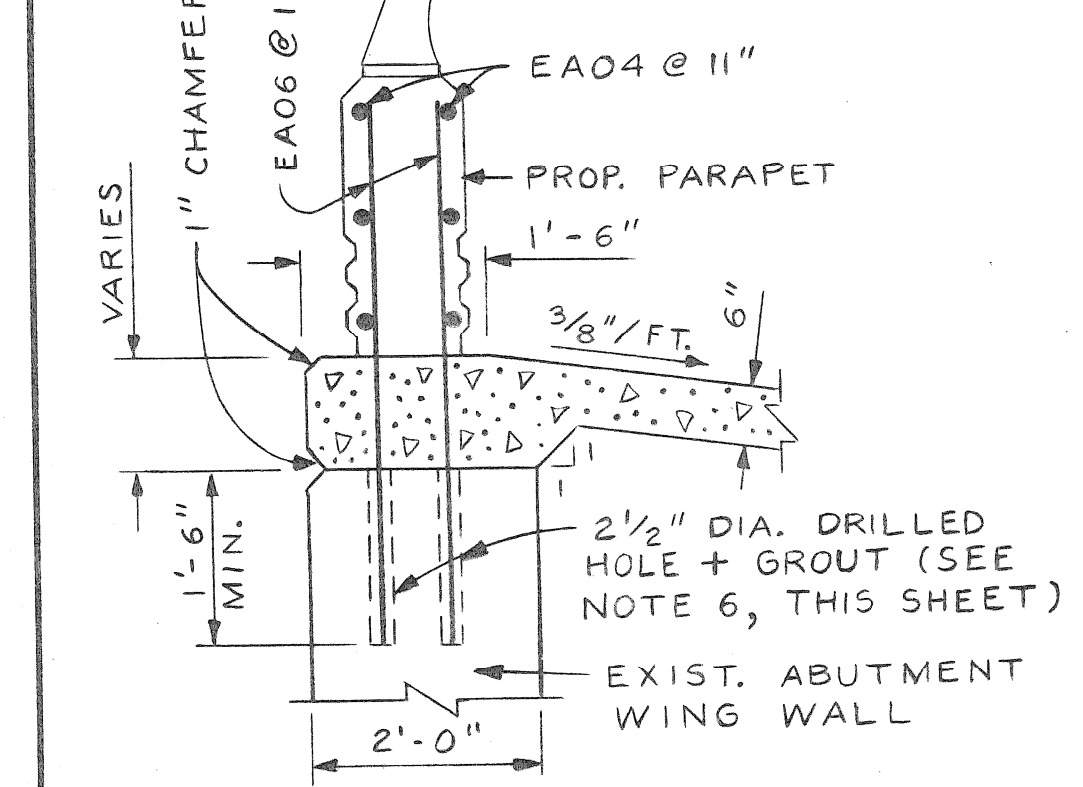
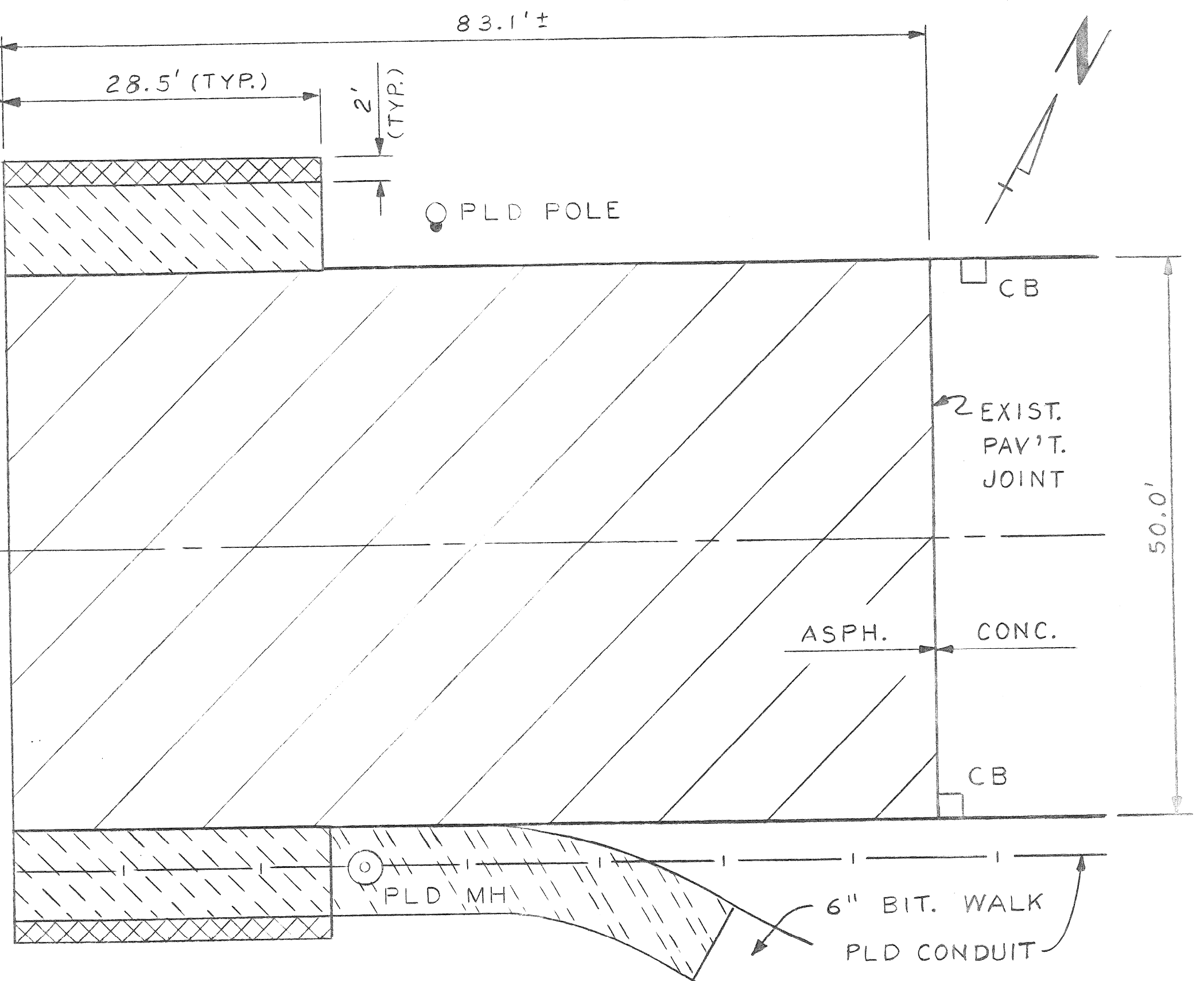

- REMOVAL LEGEND**
- (S) ABANDONING DRAINAGE STRUCTURE
  - [Hatched] REMOVING PAVEMENT (ASPHALT)
  - [Hatched] REMOVING PAVEMENT (CONCRETE)
  - [Hatched] REMOVING SIDEWALK
  - [Hatched] REMOVING BITUMINOUS SIDEWALK
  - [Hatched] REMOVING CONCRETE BRIDGE PARAPET

- TYPICAL SECTION LEGEND**
- [Dotted] AGGREGATE BASE UNDER CONCRETE (4" IN PLACE)
  - [Cross-hatched] GRANULAR MATERIAL CLASS II
  - [Hatched] BITUMINOUS SIDEWALK, 4"
  - [Hatched] CLASS "A" SODDING WITH 3" TOPSOIL
  - (B<sub>D</sub>) OPTIONAL B OR D LONGITUDINAL JOINT

- PAVING PLAN LEGEND**
- (C) TRANSVERSE CONTRACTION JOINT
  - (E) TRANSVERSE EXPANSION JOINT
  - [Hatched] CONC. PAV'T. WITH INTEGRAL CURB - REINF. 9"
  - [Hatched] CONCRETE SIDEWALK, 6"
  - [Hatched] BITUMINOUS SIDEWALK, 4" (SEE NOTE 5 ON SHEET NO. S-12).
  - [Cross-hatched] BRIDGE PARAPET ON CONCRETE WALK
  - [Dotted] CLASS "A" SODDING WITH 3" TOPSOIL
  - [Dotted] BACKFILL AND CLASS "A" SODDING
  - [Dotted] CLASS C-76-III 12" SEWER IN TRENCH DETAIL B

- NOTES**
- SUBGRADE UNDERCUTTING SHALL BE AS DIRECTED BY THE ENGINEER.
  - INCLUDE BITUMINOUS WALK REMOVAL WITH EARTH EXCAVATION.
  - REMOVING PAVEMENT (ASPHALT) AND REMOVING PAVEMENT (CONCRETE) SHALL BE PAID FOR AS REMOVING PAVEMENT.
  - TYPE B JOINT DENOTES AN MDOT LONGITUDINAL BULKHEAD JOINT; TYPE D JOINT DENOTES AN MDOT LONGITUDINAL LANE TIE JOINT.
  - FOR A PROFILE VIEW OF THE EXISTING BRIDGE PARAPET SEE SHEET NO. S-2.
  - THIS WORK INCLUDED IN PAY ITEM: "BRIDGE RAILING, SOLID PARAPET TYPE".
  - FOR DETAILS OF THE PROPOSED PARAPET SEE SHEET NO. S-2. SEE ALSO MDOT STANDARD PLAN X-18D, "BRIDGE RAILING, SOLID PARAPET TYPE".
  - TRANSVERSE CONTRACTION JOINTS ON APPROACH SIDEWALKS SHALL BE SPACED AT 6' INTERVALS.
  - PROVIDE DOUBLE-YELLOW & PAVEMENT MARKINGS CONFORMING TO DETROIT DOT FIELD MARKING STANDARDS NO. SG-50. MARKINGS ARE TO BE OF POLYESTER MATERIAL.
  - SEE ALSO NOTES ON SHEET NO. S-12.

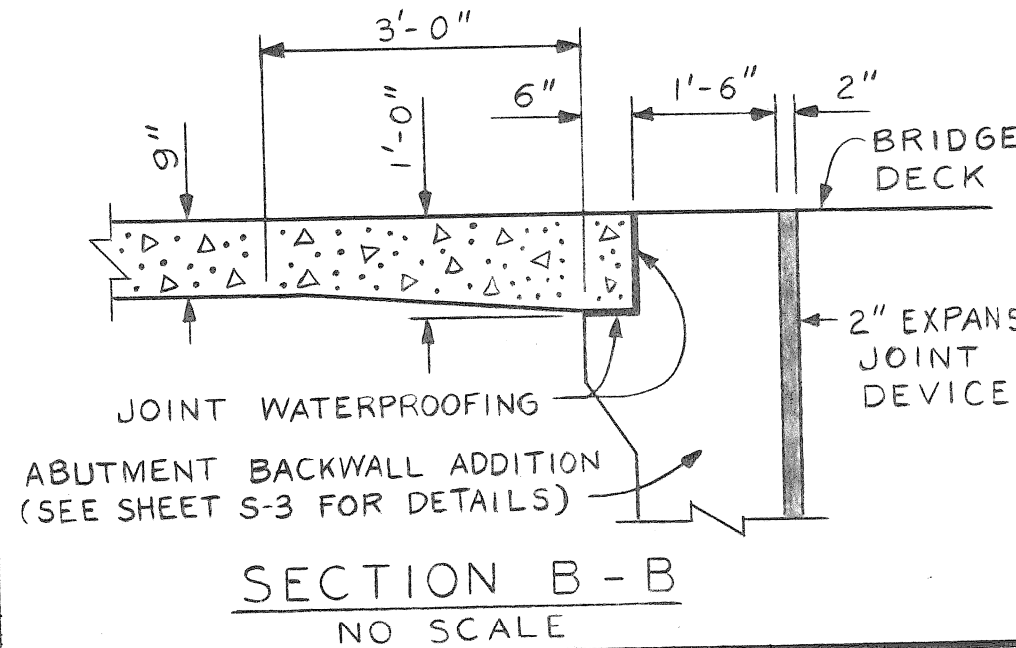
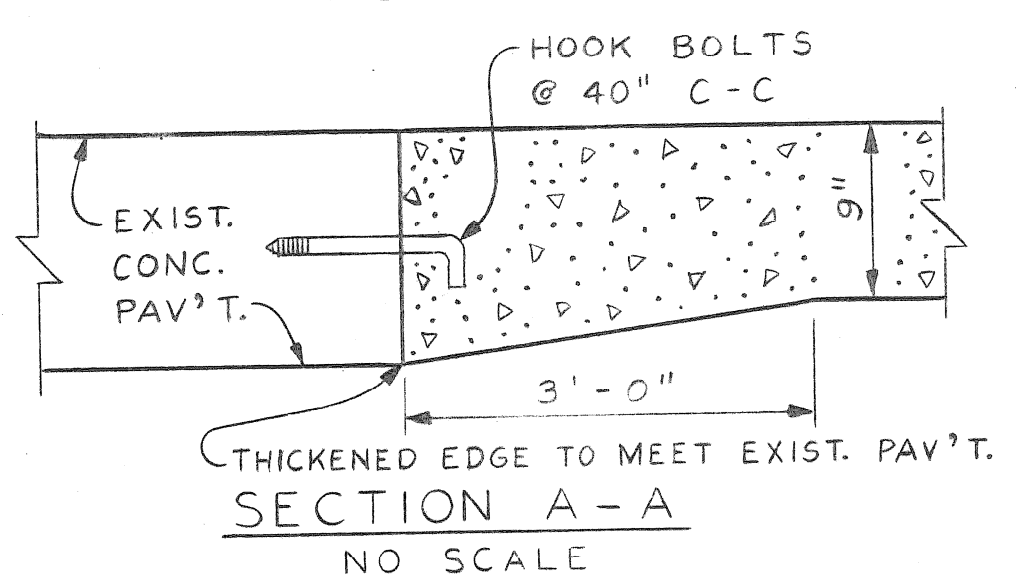
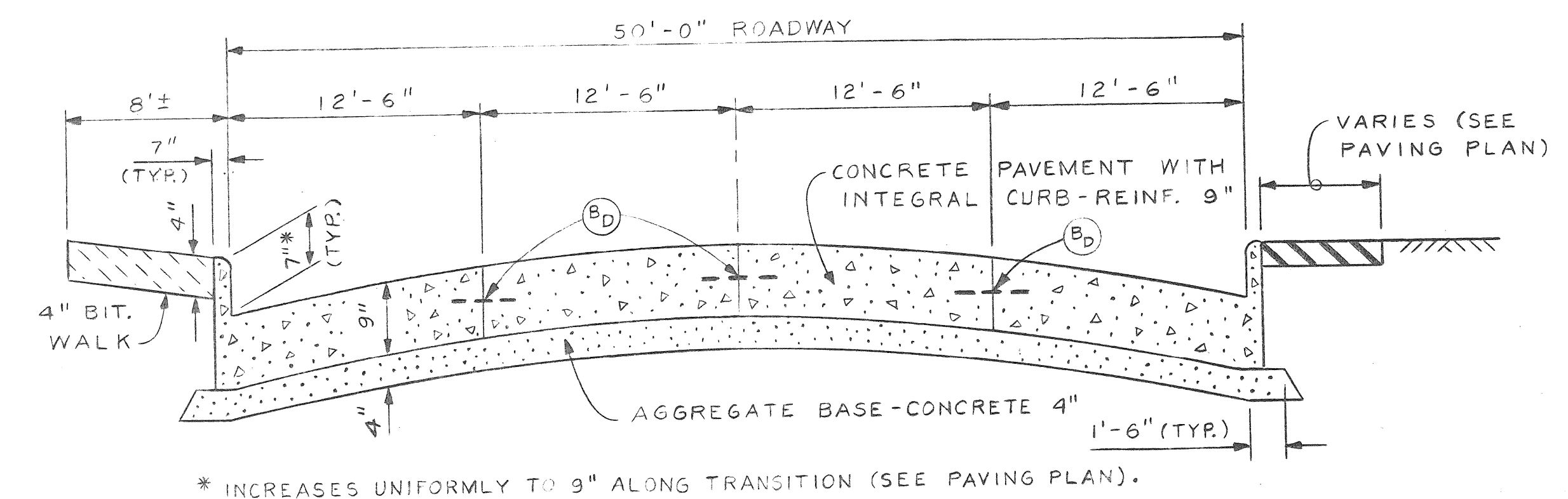
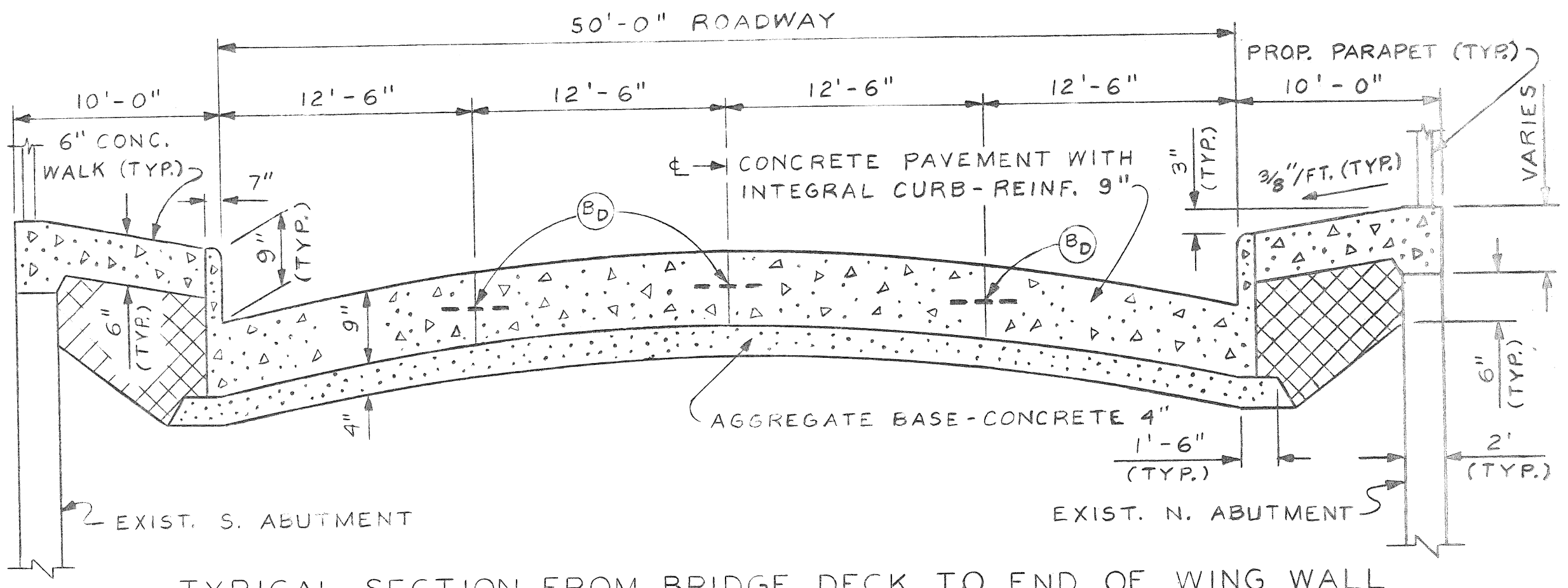

- (A) CATCH BASIN "A"
- (B) CATCH BASIN "B" W/O TRAP
- (D) ADJUSTING DRAINAGE STRUCTURE COVER, CASE 2

REVISIONS	DESCRIPTION	DR	N	CK	D	AP	VD	DATE	BY	CHECKED BY	APPROVED
									PLAN	GRADE	ESTIMATE
									N.W.		
									N.W.		

CITY OF DETROIT  
CITY ENGINEERING DIVISION, D.P.W.  
BUREAU OF STREETS AND HIGHWAYS

SPINOZA DR. BRIDGE OVER ROUGE RIVER (BW-270)  
APPROACH REMOVAL PLAN, TYPICAL SECTIONS & DETAILS

SHEET 5-11 OF SHEETS
CONTRACT NO.
ASSIGNMENT NO. 93-22-16
DATE APR., 1996

JOB NO. 36916A



**NOTES:**

- FOR SURVEY BENCH MARK LOCATIONS AND ELEVATIONS SEE SHEET NO. S-3.
- ADD 90.00 TO ELEVATIONS SHOWN.
- FOR ELEVATIONS SHOWN, "W" DENOTES TOP OF WALK ELEVATIONS. ALL OTHER ELEVATIONS SHOWN ARE PAVEMENT SURFACE ELEVATIONS.
- FOR PAVING PLAN LEGEND, CROSS SECTIONS AND DETAILS, SEE SHEET NO. S-12.
- REPLACE DISTURBED BITUMINOUS WALK WITH 1" MDOT BIT. MIX 36A OVER 3" MDOT BIT. MIX 3C OR OTHER APPROVED MIXTURES AS DIRECTED BY THE ENGINEER.
- RESTORE DISTURBED GROUND AREAS WITH CLASS "A" SODDING ON 3" TOPSOIL AS DIRECTED BY THE ENGINEER.
- LOCATIONS OF PLD CONDUIT ARE BASED UPON AVAILABLE RECORDS & ARE NOT GUARANTEED FOR ACCURACY.
- FOR PLD CONDUIT RELOCATIONS, AND MANHOLE RECONSTRUCTION, SEE SHEET NO. S-3.
- BACKFILL ERODED EMBANKMENT WITH SELECTED EXCAVATED MATERIAL (INCIDENTAL TO CONSTRUCTION)
- SEE ALSO NOTES ON SHEET NO. S-11.
- PLD POLE TO BE RELOCATED BY PLD.
- PLD OVERHEAD LINE TO BE DEACTIVATED BY PLD DURING CONSTRUCTION.

SCALE	HORIZONTAL	BOOK NO.	PG.	LEVEL DATE	BEFORE STARTING CONSTRUCTION CONTRACTOR MUST CHECK WITH UTILITIES FOR LOCATIONS OF EXISTING STRUCTURES WHETHER OR NOT INDICATED ON PLANS.
	VERTICAL				

PAY QUANTITIES		
ITEMS	QUANTITY	PAY UNIT
CATCH BASIN, TYPE A	2	EACH
CATCH BASIN, TYPE B WITHOUT TRAP	1	EACH
CONCRETE SIDEWALK, 6"	1,064	SFT
POLYESTER PAVEMENT MARKING, 4" YELLOW	336	LFT
CLASS A SODDING	135	SYD
WATER	1	UNIT
TOPSOIL SURFACE, 3"	135	SYD

**DRAINAGE STRUCTURE NOTES**

- INSTALL 12" DIA. C-76 III SEWERS IN TRENCH DETAIL B.
- VERIFY DIAMETERS, INV. ELEVATIONS & DIRECTION OF FLOW OF EXISTING SEWERS IN THE FIELD.
- ENCASE CONNECTIONS OF PROPOSED & EXISTING SEWERS IN CONCRETE.
- FOR DRAINAGE STRUCTURE DETAILS SEE SHEET NO. S-13.

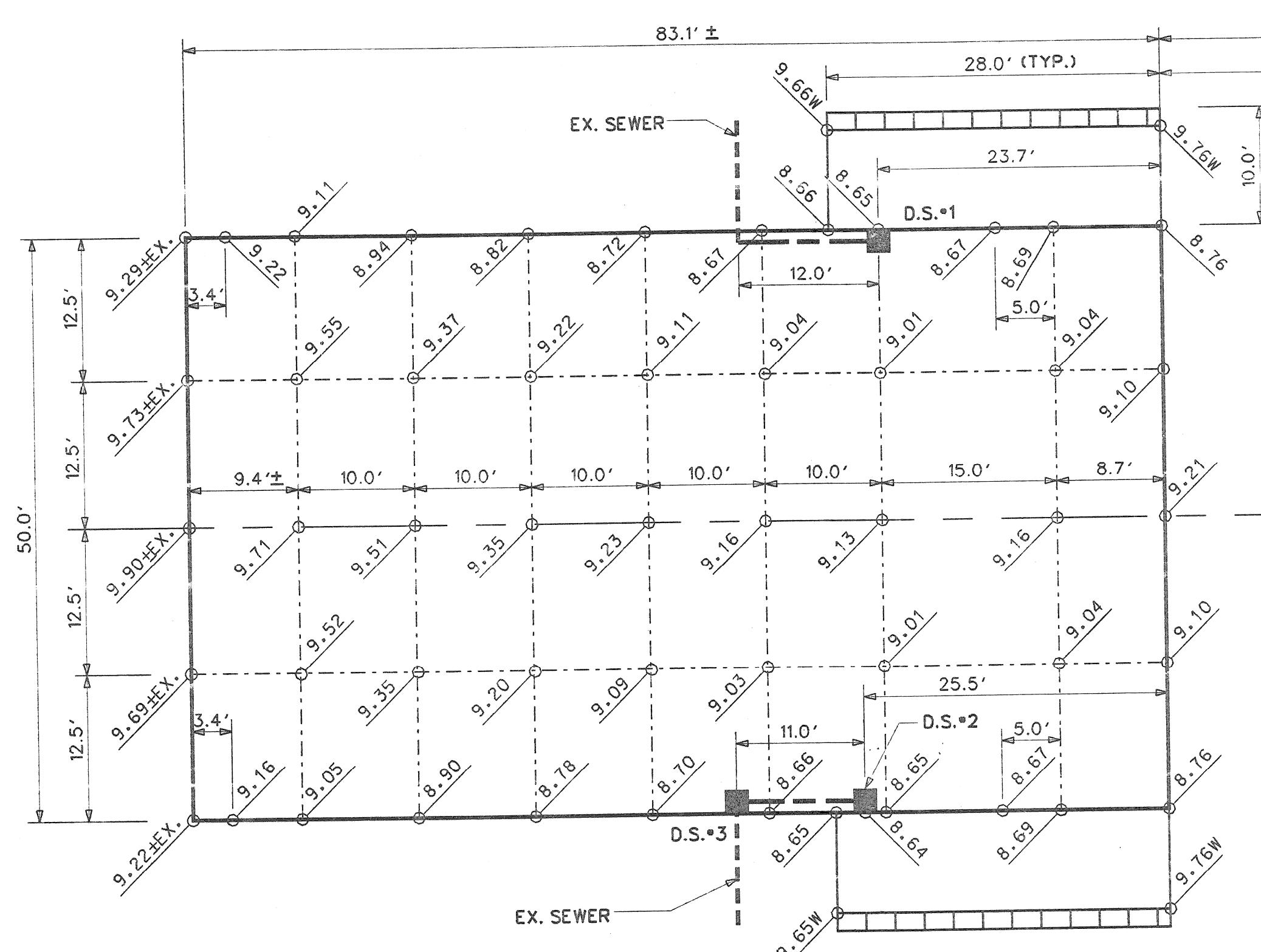
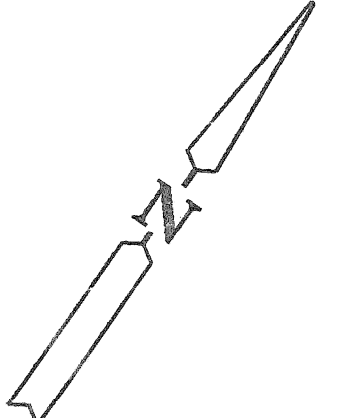

**DETAILED GRADES**  
SCALE: 1"=10'

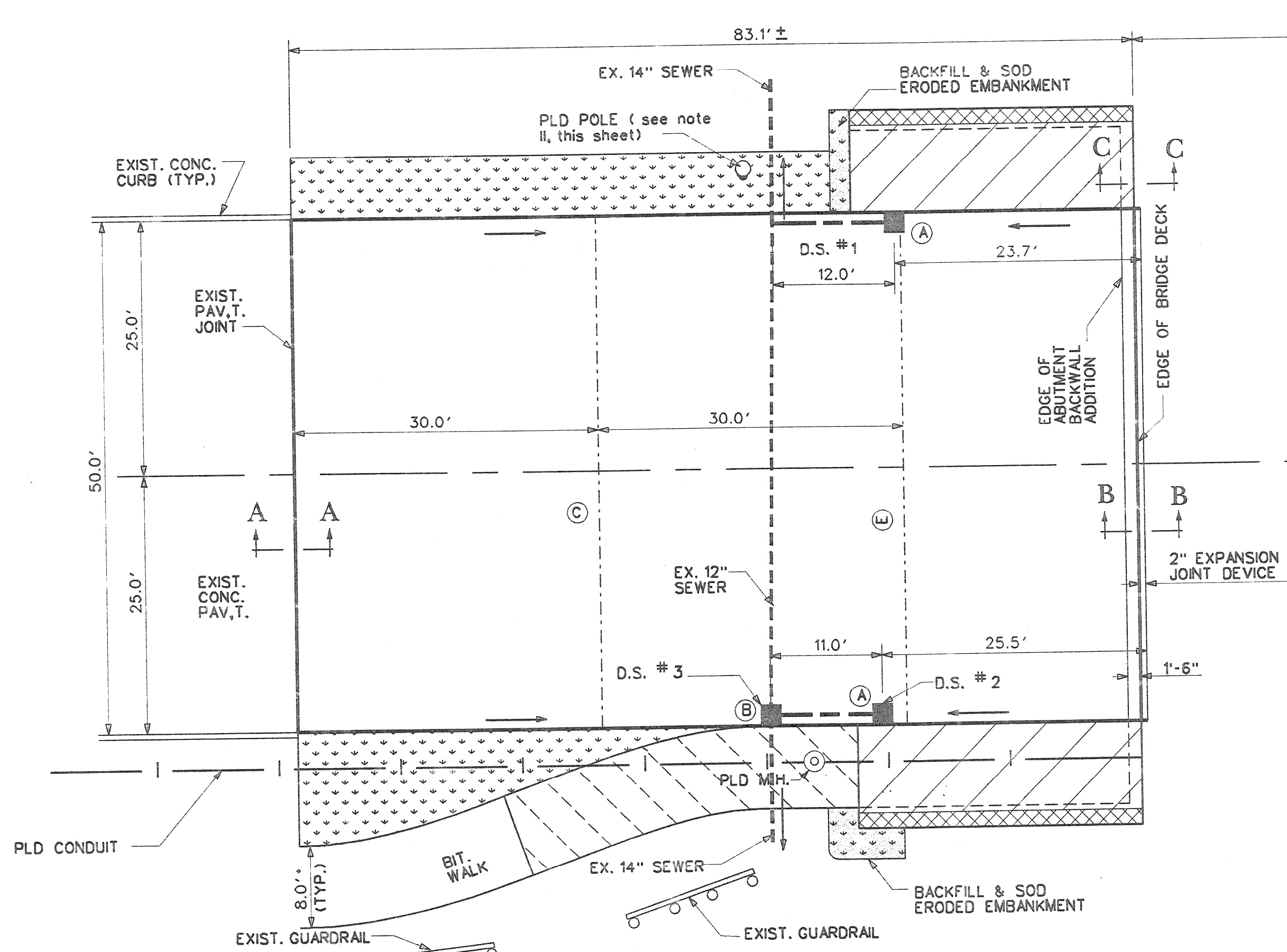
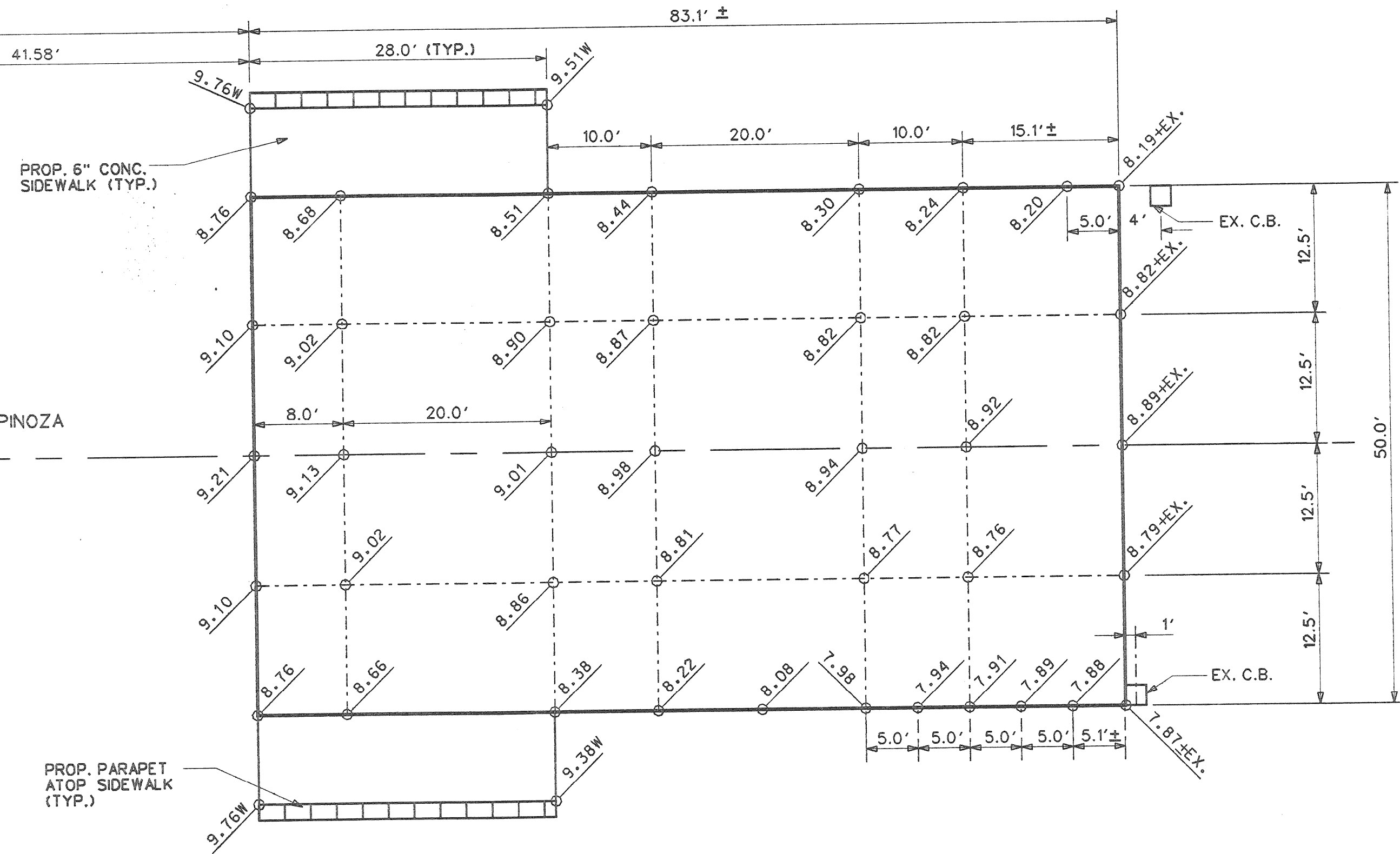

ADDITIONAL PAY QUANTITIES		
ITEMS	QUANTITY	PAY UNIT
GRANULAR MATERIAL CLASS II	35	CYD
AGGREGATE BASE UNDER CONCRETE (4" IN PLACE)	990	SYD
BITUMINOUS MIXTURE-36A	3	TON
BITUMINOUS MIXTURE-3C	10	TON
CONCRETE PAVEMENT WITH INTEGRAL CURB-REINFORCED 9"	950	SYD
BRIDGE RAILING SOLID PARAPET TYPE	112	LFT
CLASS C-76-III SEWER, 12" TRENCH DETAIL B	25	LFT
SEWER CLEANOUT	200	LFT

**PAVING PLAN**  
SCALE: 1"=10'

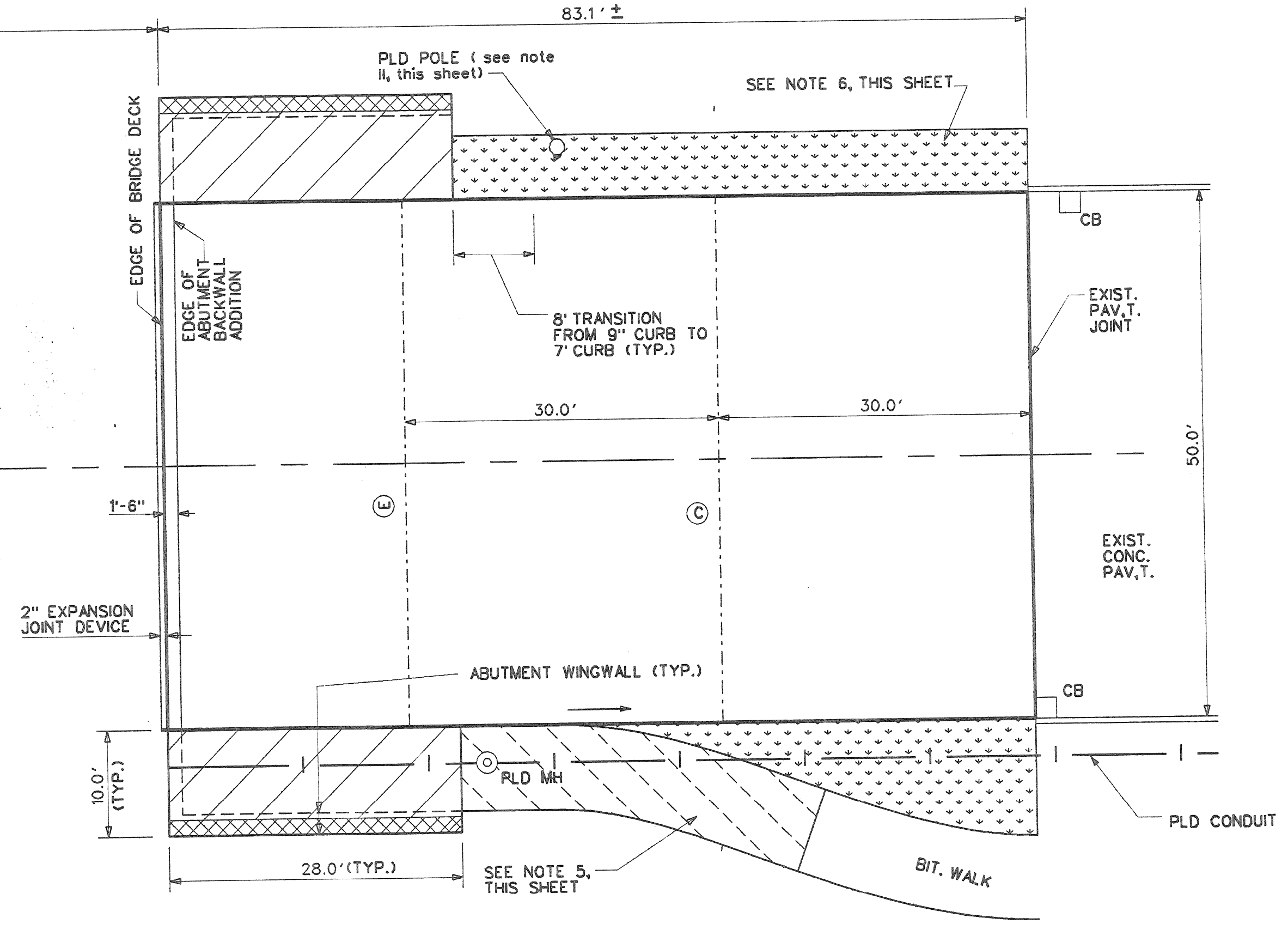

JOB NO. 36916A

DESCRIPTION	DR	CHK	APP	DATE
REVISIONS				
PLAN	N.W.,K.M.	CHECKED BY	APPROVED:	
GRADE	N.W.,K.M.			
ESTIMATE				
FINAL	*****			

CITY OF DETROIT  
CITY ENGINEERING DIVISION - D.P.W.  
BUREAU OF STREETS AND HIGHWAYS

SPINOZA DRIVE BRIDGE OVER ROUGE RIVER (BW-270)  
APPROACH PAVING PLAN AND DETAILED GRADES

SHEET S-12 OF SHEETS
CONTRACT NO.
ASSIGNMENT NO. 93-22-16
DATE APR. 1996



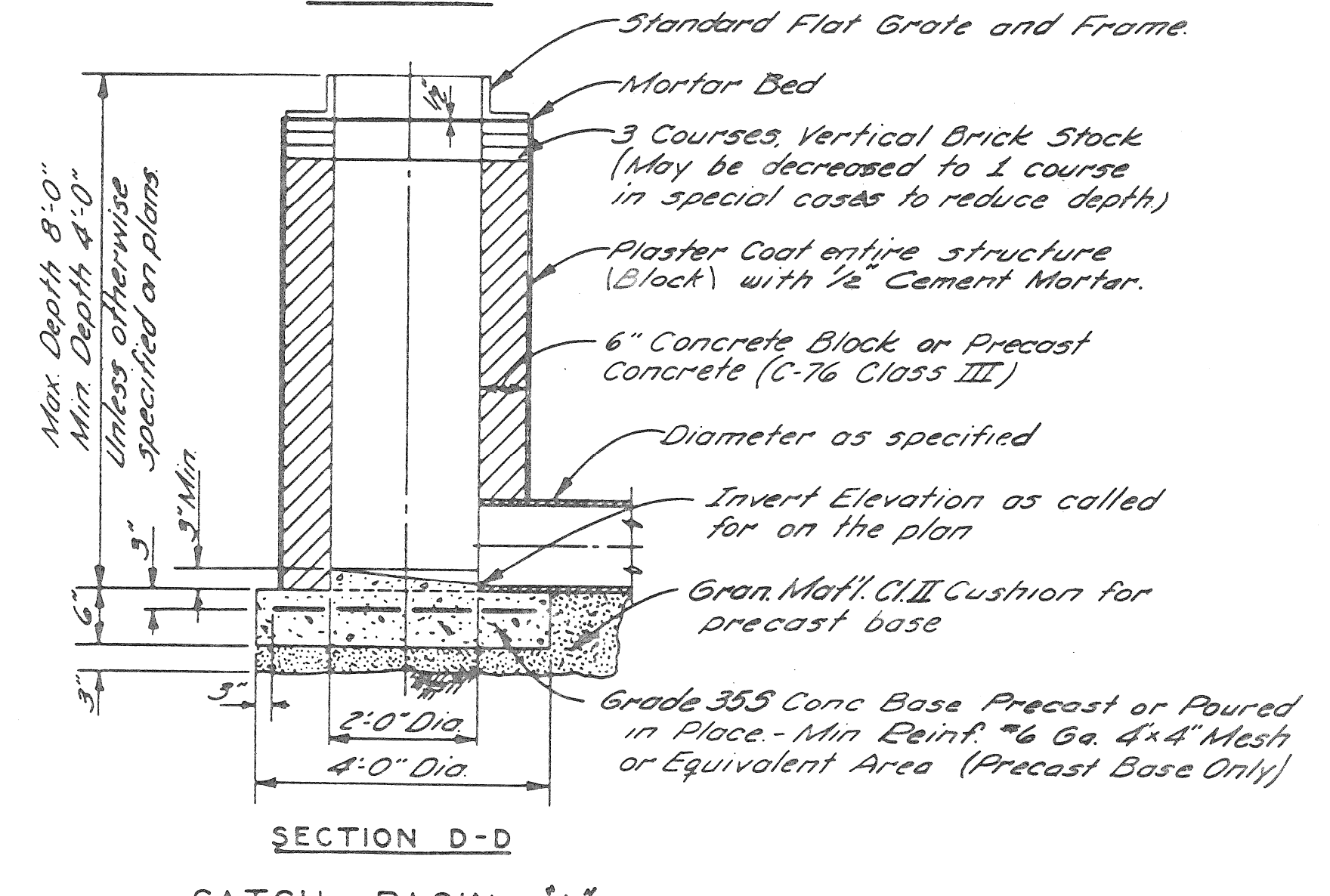
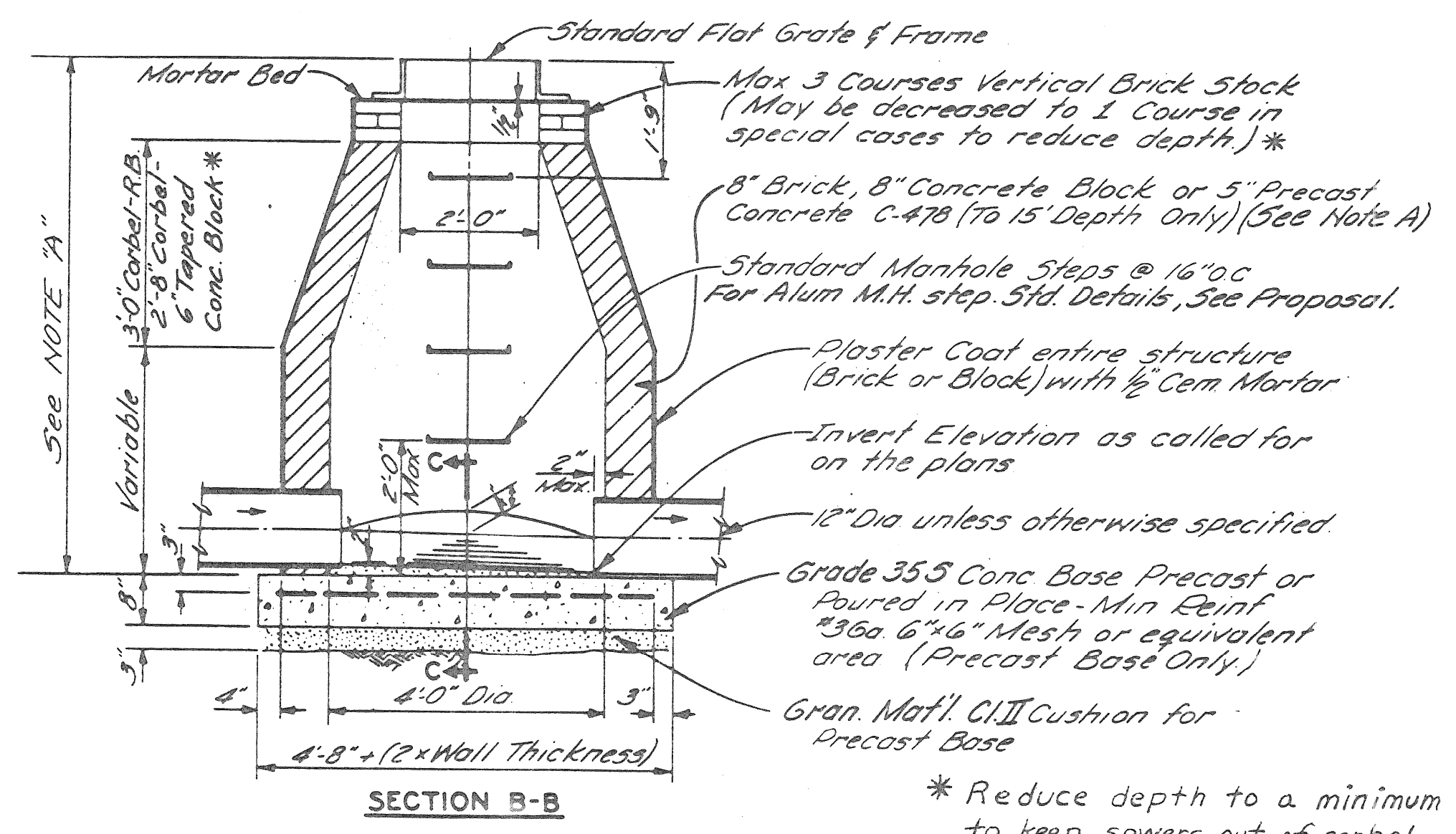
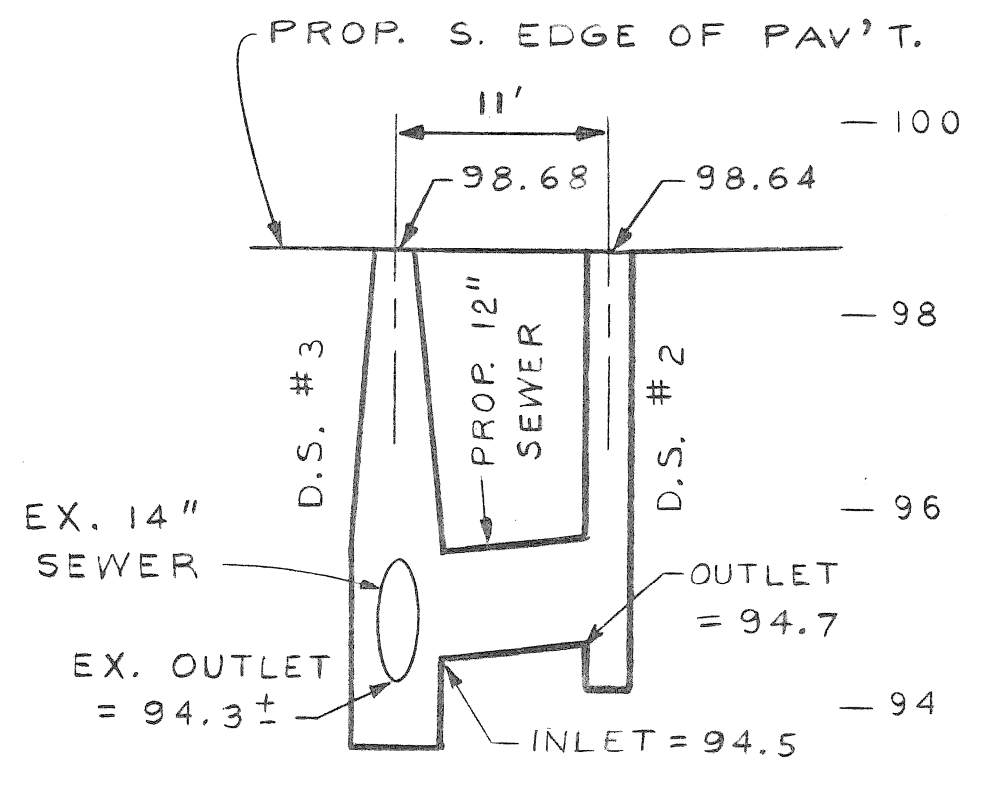
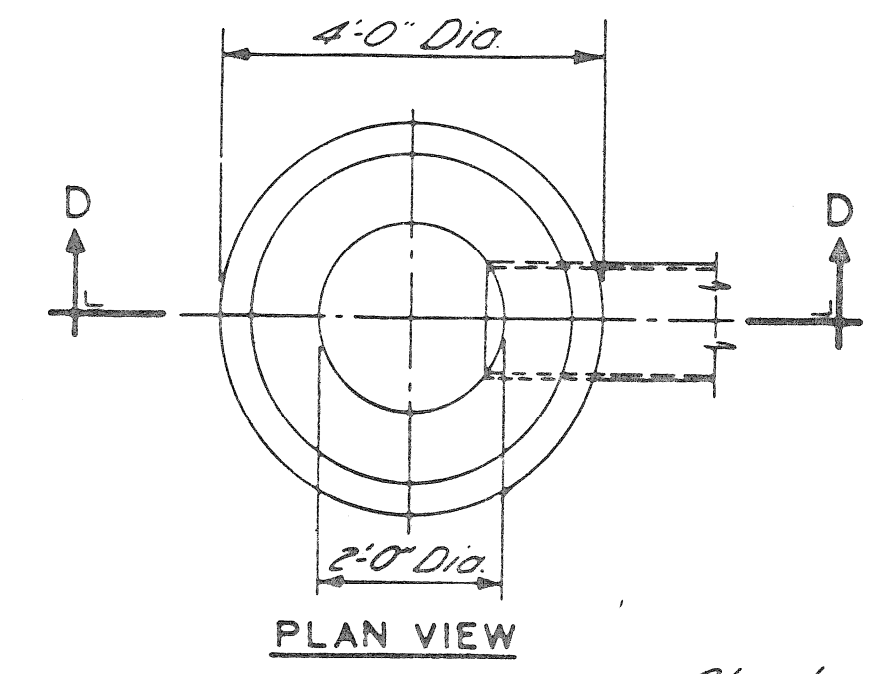
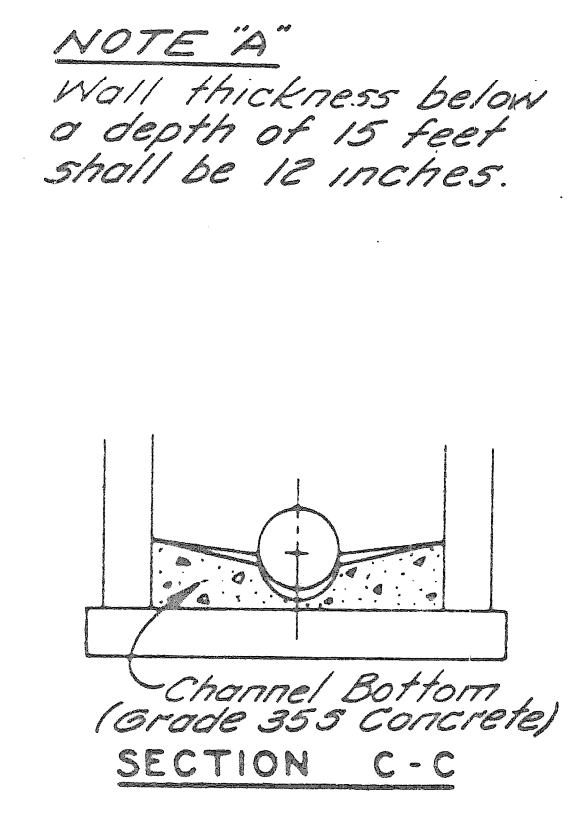
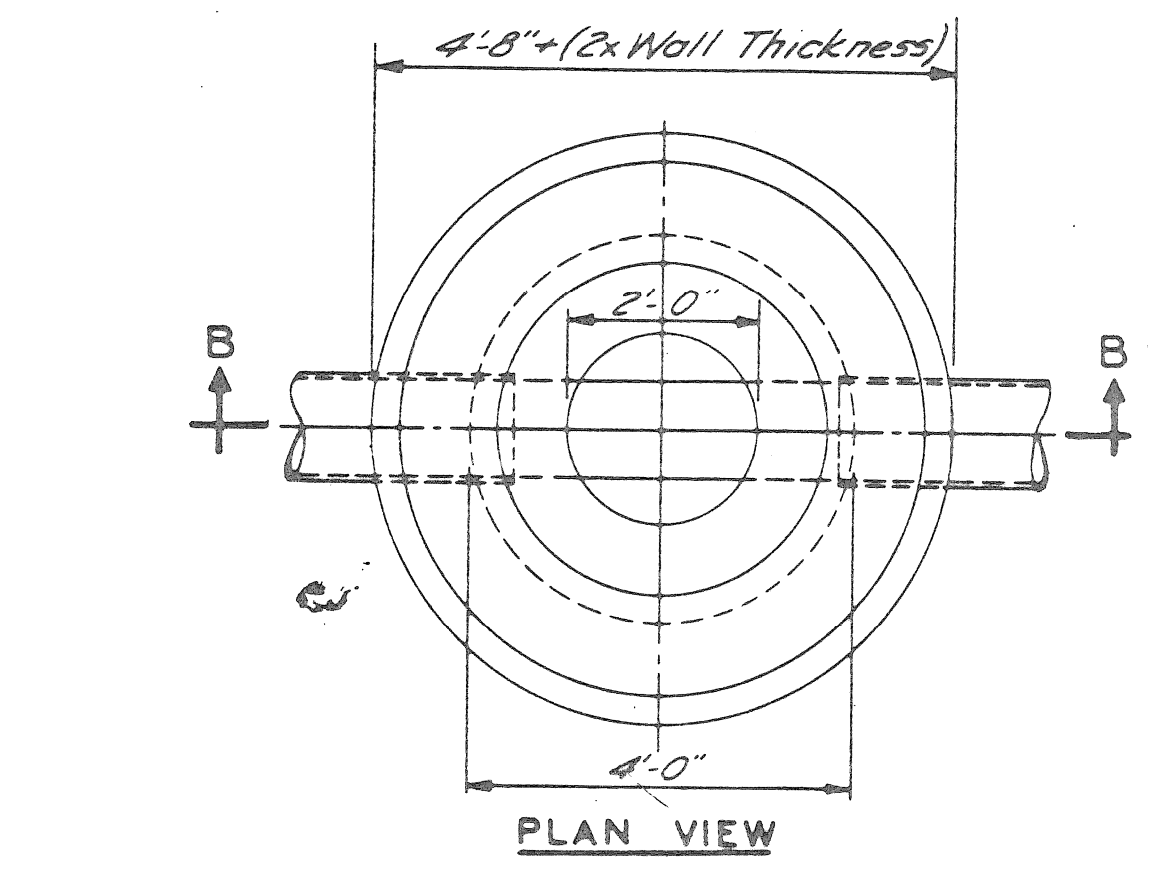
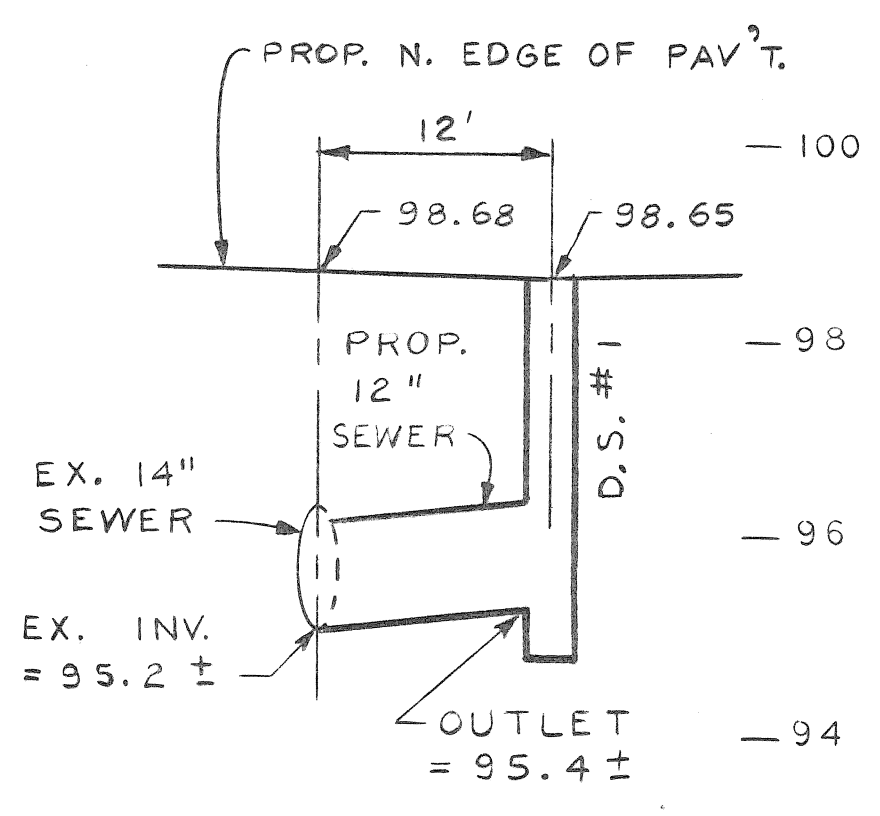

**DRAINAGE STRUCTURE PROFILES**  
SCALE: 1" = 10' HORIZ.  
1" = 2' VERT.

**CATCH BASIN "B"**  
NO SCALE

**CATCH BASIN "A"**  
NO SCALE

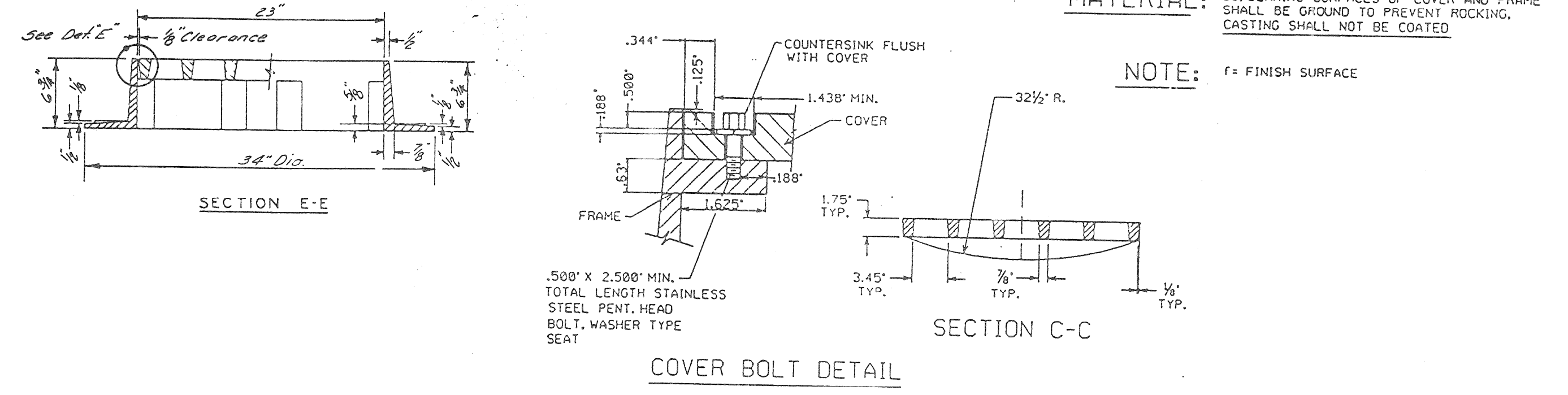
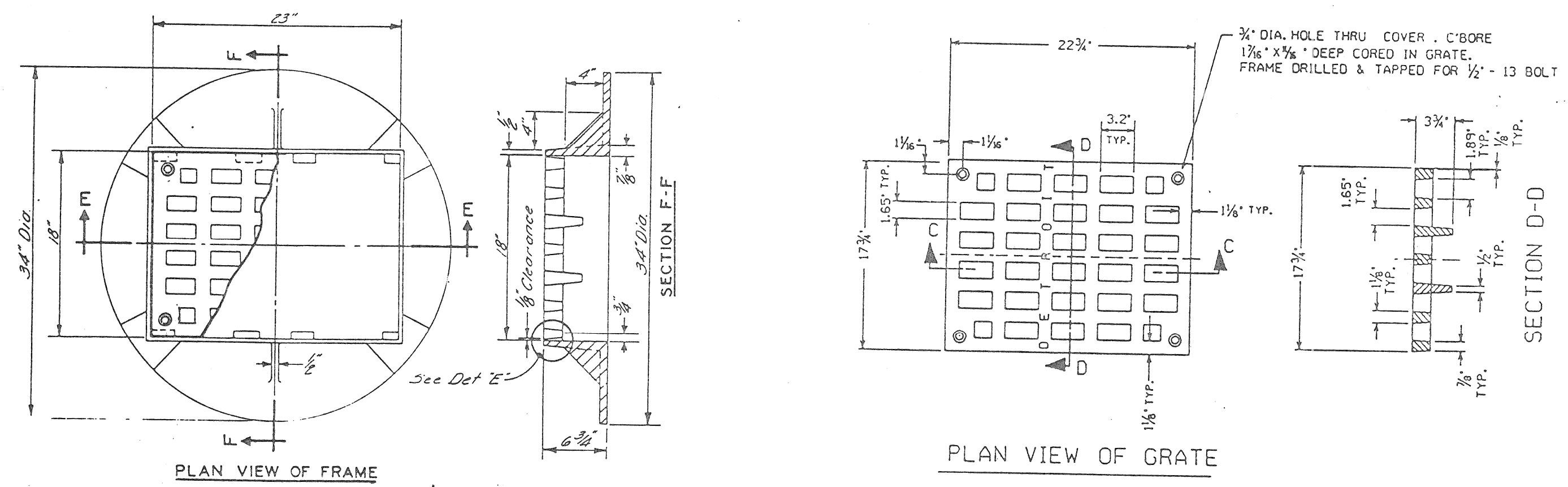

**STANDARD FLAT GRATE AND FRAME**  
NO SCALE

**GENERAL NOTES**

- The materials & workmanship shall be in accordance with the current Standard Specifications.
- Center of Catch Basin shall be 20 inches from back of curb.
- All sizes of flow lines of pipe, and elevations for top & bottom of structures shall be determined from the plans or construction requirements. The bell shall be removed from the first length of outlet pipe projecting through the wall of the structures. When any structure is constructed of precast concrete or concrete block, the top of the masonry shall be left sufficiently low to permit proper adjustment of cover to grade by the use of mortar or bricks as directed by the Engineer.
- A plaster coat of mortar 1/2 inch in thickness shall be applied to the outer surface of the structure as shown. A 1/2 inch cement plaster coat shall be placed on the inside of all sumps.
- Contractor shall verify elevations of existing utilities to enable construction to indicated elevations shown on drawings. If necessary, invert elevations shown on the drawings may be altered in the field to clear existing utilities. Such alterations, upward or downward, shall be at no change in contract price.
- When precast concrete pipe sections are used for catch basins, either a section of the inlet and outlet pipes or an opening or eye for the inlet & outlet pipes shall be cast into the wall of the catch basin pipe when it is being manufactured. Eyes in precast pipe sections shall be furnished to accommodate a flexible joint connection such as Press-Wedge by Press-Seal Gasket Corp or Res-Seal by Seales, Mfg. Corp.

DESCRIPTION	DR	N	CK	D	AP	VD	DATE
REVISIONS							
BY	N.W.		CHECKED BY	APPROVED:			
GRADE			ENGINEER OF STREETS				
ESTIMATE							
FINAL	CHECK	REVIEW					

**CITY OF DETROIT**  
CITY ENGINEERING DIVISION, D.P.W.  
BUREAU OF STREETS AND HIGHWAYS

**SPINOZA BRIDGE OVER ROUGE RIVER (BW-270)**  
DRAINAGE STRUCTURE DETAILS

JOB NO. 36916

S-13	OF	SHEETS
NO. ACT		
ASSIGNMENT NO. 93-22-16		
DATE APR., 1996		